

1091

# L. G. RADOSEVICH

NRL Memorandum Report 4267

## Energy Storage As Heat-of-Fusion in Containerized Salts

T. A. CHUBB, J. J. NEMECEK, AND D. E. SIMMONS

*X-ray Astronomy Branch  
Space Science Division*

June 27, 1980

This research was sponsored jointly by

UNITED STATES OFFICE OF NAVAL RESEARCH  
Under Contract No. RR 024-01-45

UNITED STATES DEPARTMENT OF ENERGY  
Under Contract No. EC-77-A-31-1024



**NAVAL RESEARCH LABORATORY**  
**Washington, D.C.**

Approved for public release; distribution unlimited.

## DISCLAIMER

This report was prepared as an account of work sponsored by an agency of the United States Government. Neither the United States Government nor any agency thereof, nor any of their employees, makes any warranty, express or implied, or assumes any legal liability or responsibility for the accuracy, completeness, or usefulness of any information, apparatus, product, or process disclosed, or represents that its use would not infringe privately owned rights. Reference herein to any specific commercial product, process, or service by trade name, trademark, manufacturer, or otherwise, does not necessarily constitute or imply its endorsement, recommendation, or favoring by the United States Government or any agency thereof. The views and opinions of authors expressed herein do not necessarily state or reflect those of the United States Government or any agency thereof.

Printed in the United States of America  
Available from  
National Technical Information Service  
U.S. Department of Commerce  
5285 Port Royal Road  
Springfield, VA 22161

Printed copy: \$9.00  
Microfiche copy: A06

SECURITY CLASSIFICATION OF THIS PAGE (When Data Entered)

REPORT DOCUMENTATION PAGE		READ INSTRUCTIONS BEFORE COMPLETING FORM
1. REPORT NUMBER NRL Memorandum Report 4267	2. GOVT ACCESSION NO.	3. RECIPIENT'S CATALOG NUMBER
4. TITLE (and Subtitle) ENERGY STORAGE AS HEAT-OF-FUSION IN CONTAINERIZED SALTS		5. TYPE OF REPORT & PERIOD COVERED Interim report on a continuing NRL problem
		6. PERFORMING ORG. REPORT NUMBER
7. AUTHOR(s) T.A. Chubb, J.J. Nemecek and D.E. Simmons		8. CONTRACT OR GRANT NUMBER(s) DOE Contract EC-77-A-31-1024
9. PERFORMING ORGANIZATION NAME AND ADDRESS Code 4120 Naval Research Laboratory Washington, D.C. 20375		10. PROGRAM ELEMENT, PROJECT, TASK AREA & WORK UNIT NUMBERS RR 024-01-45 71-0937-0 71-0936-0
11. CONTROLLING OFFICE NAME AND ADDRESS U.S. Department of Energy Division of Energy Storage Systems		12. REPORT DATE June 27, 1980
		13. NUMBER OF PAGES 108
14. MONITORING AGENCY NAME & ADDRESS (if different from Controlling Office) Dick Vernon NASA/Lewis Research Center Cleveland, OH 44135		15. SECURITY CLASS. (of this report) UNCLASSIFIED
		15a. DECLASSIFICATION/DOWNGRADING SCHEDULE
16. DISTRIBUTION STATEMENT (of this Report)  Approved for public release; distribution unlimited		
17. DISTRIBUTION STATEMENT (of the abstract entered in Block 20, if different from Report)		
18. SUPPLEMENTARY NOTES  Work jointly sponsored by ONR and DOE		
19. KEY WORDS (Continue on reverse side if necessary and identify by block number)  Energy Storage Heat-of-Fusion Containerized Salts		
20. ABSTRACT (Continue on reverse side if necessary and identify by block number)  This report is concerned with energy storage based on heat-of-fusion in containerized salt. The "energy storage boiler tank" uses evaporation and condensation of a heat transfer fluid to provide heat transfer into and out of stacked cans of salt. The "energy storage superheater tank" uses a network of alkali metal heat pipes to distribute heat throughout a building filled with salt cans. It uses radiation to transfer energy to and from stacked cans of salt. The paper summarizes the rationale for energy storage in containerized salt, it discusses salt selection, salt availability, salt processing, container requirements, can technology and heat transfer fluid degradation problems. <p style="text-align: right;">(Continued)</p>		

DD FORM 1473  
1 JAN 73

EDITION OF 1 NOV 65 IS OBSOLETE  
S/N 0102-014-6601

i

SECURITY CLASSIFICATION OF THIS PAGE (When Data Entered)

20. Abstract (Continued)

These discussions lead to estimates of energy storage system costs.

The Naval Research Laboratory is building a 2 MWh proof-of-concept energy storage boiler tank. Laboratory investigations studying the compatibility of the heat transfer fluid with the molten storage salt are described, along with measurements of temperature drops associated with the energy input process. An assessment of the current status of the energy storage boiler tank is presented.

UC-94a

# Energy Storage As Heat-of-Fusion in Containerized Salts

Project 71-0937-0-0  
Report on Energy Storage Boiler Tank

T.A. CHUBB, J.J. NEMECEK, AND D.E. SIMMONS

Prepared by

Naval Research Laboratory  
Washington, D.C. 20375  
Code 7120

Date Published — June 1980



## CONTENTS

SUMMARY .....	ix
I. INTRODUCTION .....	1
II. ENERGY STORAGE RATIONALE .....	2
1. Rationale for Thermal Storage .....	2
2. Scaling the Problem .....	4
3. Raw Material Availability .....	4
4. Processing Costs and Transportation .....	5
5. Initial Costs of Storage Systems Based on MgCl <sub>2</sub> , NaCl, KCl Eutectic) .....	8
III. HEAT-OF-FUSION ENERGY STORAGE TECHNOLOGY .....	10
1. Thermal Conductivity—Rationale for Containerizing Salts .....	10
2. Input-Output .....	10
3. Internal Heat Transfer .....	11
a. Energy Storage Boiler Tank .....	14
b. Radiation Coupled Energy Storage Tank .....	16
IV. ENERGY STORAGE AT 385°C (725°F) .....	19
1. Potential Problem Areas .....	19
a. Corrosion .....	19
b. Degradation of m-Terphenyl Heat Transfer Fluid .....	20
c. Fractionation .....	20
d. Repurification of Heat Transfer Fluid .....	21
e. Salt Crusting and Porosity .....	22
2. Separately Manifolded, Conductivity Enhanced Cans .....	22
3. Container Materials, Technology, and Costs .....	25
4. Salt Procurement and Preparation .....	28
V. 2 MWht TANK .....	32
1. Test Rationale .....	32
2. Tank Construction .....	33
3. Tank Specifications .....	38
4. Analysis of Heat Flow in Salt .....	38
5. Water-Steam System .....	38
6. Terphenyl Loop and Bleed .....	49
7. Insulation Transport Loop .....	54
8. Site Plans .....	54
VI. STATUS OF PROOF-OF-CONCEPT STUDY .....	56

APPENDIX A – Chemical vs. Thermal Storage for Solar Thermochemical Power Systems .....	59
APPENDIX B – Salt Cost Calculations .....	63
APPENDIX C – Measurement of Heat-of-Fusion of MgCl <sub>2</sub> , NaCl, KCl Eutectic .....	69
APPENDIX D – Design of Condensation Boilers and Superheaters .....	75
APPENDIX E – Calculations Relevant to Radiation Coupled Energy Storage Tank .....	78
APPENDIX F – Heat Transfer Fluid Technology, Costs, Toxicity for 385°C Use .....	84
APPENDIX G – Container Technology and Costs .....	89
APPENDIX H – Laboratory Studies on Energy Input Heat Transfer and Materials Compatability for a 385°C Energy Storage Boiler Tank .....	91
ENERGY STORAGE BOILER TANK, PROGRESS REPORT .....	94

## LIST OF FIGURES

Figure No.		Page
Frontispiece	Artist's painting of energy storage boiler tank	i
1	Heat transfer diagram of energy storage tanks using containerized salt	12
2	Energy storage boiler tank	15
3	Radiation coupled energy storage tank	17
4	Open salt cans used in lab studies	23
5	Cans cut in cross section showing 18 X recycled salt	24
6	Energy storage boiler tank with separately manifold salt cans	26
7	Conductivity enhancement structure for use inside 12" diameter cans	27
8	Cans for 2 MWht energy storage boiler tank	29
9	Experimental 40"-long cans	30
10	Phase diagram for MgCl <sub>2</sub> , NaCl, and KCl	31
11	Cutaway drawing of 2 MWht energy storage boiler tank	34
12	Heater element for 2 MWht tank	37
13	Illustration of condensation boiler superheater concept	39
14	Condensation boiler-superheater for 2 MWh tank	40
15	Illustration of feedwater preheater concept	42
16	Calculated performance of feedwater preheat system	43
17	Calculated performance of superheater	44
18	Calculated steam pressure drop vs. energy withdrawal rate	45
19	Water-steam system	46
20	Heat transfer fluid system	50
21	Photograph of 2 MWht energy storage tank test facility	55
E-1	Radiation coupled energy storage tank on which calculations are made	79
E-2	Radiative heat transfer rates coupling salt cans to heat pipes	81
F-1	Terphenyl decomposition rate vs. temperature	86



## LIST OF TABLES

Table No.		Page
1	Salt Reserves	5
2	Cost Estimate for Energy Storage Based on $\text{MgCl}_2$ , NaCl, KCl Eutectic	9
3	Heat Transfer: Energy Storage Boiler Tank and Radiation Coupled Energy Storage Tank	13
4	NRL Specification for Solchemite A, Grade 3	32
5	Specifications: 2 MWht Tank	35
A-1	Energy Storage Boiler Tanks vs. Chemical Inventory Tank	60
B-1	Raw Salt Cost	64
B-2	Energy Costs of Dehydration	65
B-3	Breakdown of Salt Costs ( $\text{MgCl}_2$ , NaCl, KCl Eutectic	66
B-4	Raw Salt Cost (Selected Eutectics)	66
C-1	The Total Enthalpies of a Eutectic Salt	72
C-2	The Specific Heat of a Eutectic Salt	73
E-1	Energy Delivery Rates for 2 MWht Radiation Coupled Energy Storage Tank	80

## SUMMARY

Energy can be stored with only a slight drop in quality as heat-of-fusion in containerized salt eutectics. Use of salt cans of large aggregate surface area compensates for the poor thermal conductivity of the solid salt. Transfer of heat into or out of the salt cans can be effected by evaporation and cooling of a heat transfer fluid. Alternatively, a network of alkali metal heat pipes can duct heat throughout a grid interlacing an assemblage of salt cans. Such heat pipes can transfer high temperature heat to and from the salt cans by radiation.

Following a period of laboratory evaluation, a 2 MWht energy storage boiler tank containing ~30 tons of  $\text{MgCl}_2$ , NaCl, KCl eutectic is now under construction. The salt is contained in 4000 4-inch diameter cans. The tank uses m-terphenyl as a heat transfer fluid in an evaporation-condensation mode. The lid of the tank contains an integral condensation boiler-superheater, which permits delivery of energy as superheated steam at 800 psi. Specifications are given in Table 3. Heat transfer tests are expected to begin in mid 1980, with energy storage tests underway shortly thereafter.

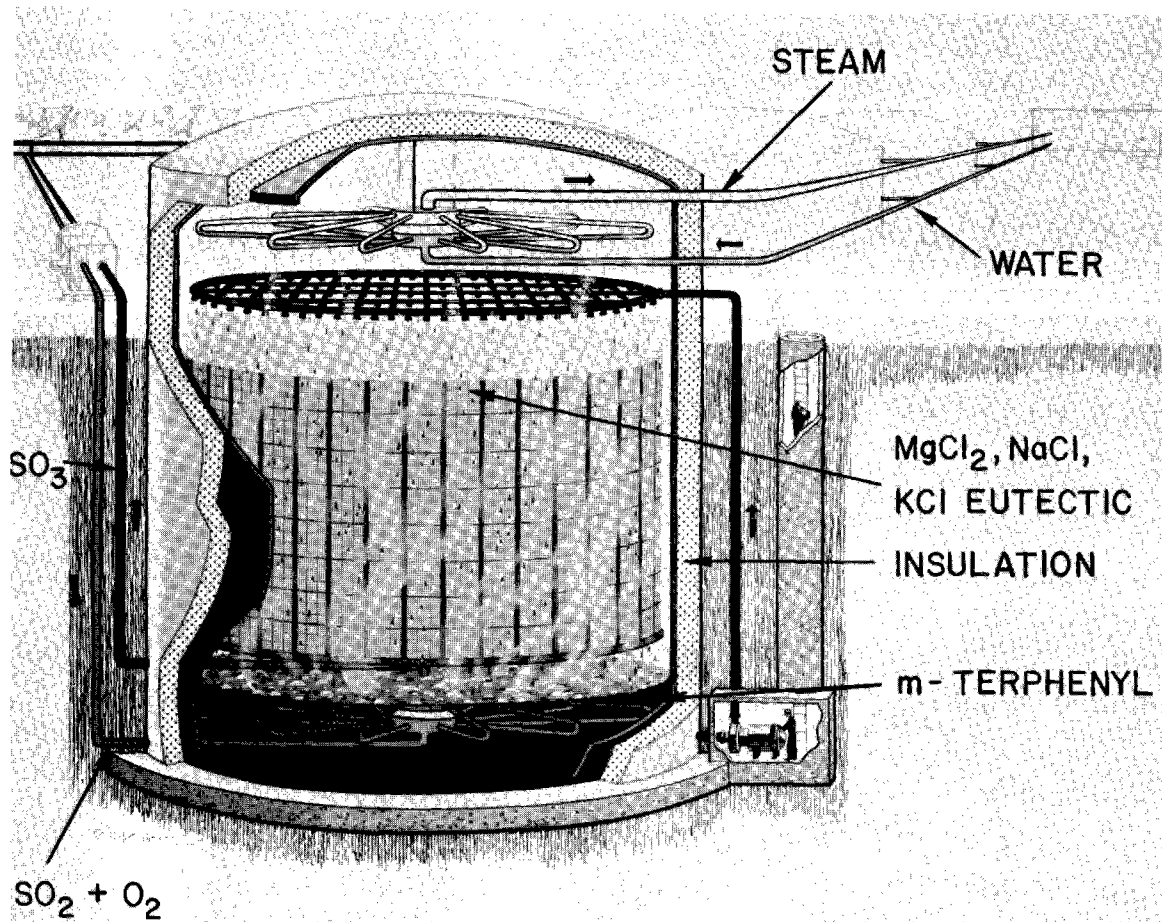

Frontispiece: Energy storage boiler tank. Figure is a photograph of a painting by Pierre Mion. The painting illustrates operation of a large energy storage boiler tank in which massive amounts of energy are stored as heat-of-fusion in containerized molten salts. Energy is introduced into the storage tank by means of a catalyzed exothermic reaction in which  $\text{SO}_2$  plus  $\text{O}_2$  are converted into  $\text{SO}_3$ . Such exothermic reactors form the energy delivery end of a Solchem type solar energy collection system. The energy storage boiler tank resembles the home pressure cooker. It uses evaporation-condensation of an m-terphenyl heat transfer fluid to provide internal heat transfer between the  $\text{SO}_3$  exothermic reactor, the many salt cans, and the steam boiler-superheater at the top of the tank. The m-terphenyl plays the same role in the energy storage boiler tank as water plays in the home pressure cooker. Energy output is on-demand superheated steam. Insulation surrounds the tank to reduce thermal losses to the environment.

# ENERGY STORAGE AS HEAT-OF-FUSION IN CONTAINERIZED SALTS

## I. INTRODUCTION

The Naval Research Laboratory is in the process of building a 2 MWht energy storage boiler tank.<sup>(1)</sup> The tank will contain 30 tons of a  $\text{MgCl}_2$ , NaCl, KCl salt eutectic. It will serve as a proof-of-concept demonstration of energy storage in containerized salts. Energy storage is provided as latent heat of fusion in the eutectic salt. The tank is energized by 150 kW electrical heaters. It's output is in the form of superheated steam, with usable output rates expected to be as high as 500 kWt. Internal heat transfer is based on evaporation/condensation of m-terphenyl heat transfer fluid. Specifications are given in Section V of this report.

Major use of industrial scale solar power will impose requirements for massive energy storage. This report addresses the salt fusion storage option. It examines the adequacy of the salt resource, and provides cost estimates associated with its use. It discusses the technology problems associated with salt storage and presents two solutions to the problem of providing efficient internal heat transfer within the storage devices. The report then focuses on the specific task of thermal storage at 385°C and on the laboratory tests and design efforts that support the construction of the 2 MWht tank. A late update on the status of the 2 MWht tank ends the report.

This report makes use of multiple appendices which contain much of the technical and costing content of the report. The appendices also include descriptions of storage options for higher and lower temperatures. Readers may wish to skip much of the general discussion and proceed directly to the later sections of the document or move directly to the Appendices.

## II. ENERGY STORAGE RATIONALE

### 1. Rationale for Thermal Storage

The storage of energy is a requirement if power is to be made continuously available to meet a time variable power demand. There are currently only a few options for storing large amounts of energy. The main practice is that of storing energy in the form of unburnt chemical or nuclear fuel. For power pools with an adequate number of large and efficient power plants this is not necessarily the preferred option, since it may be capital effective to run nuclear and high efficiency fossil fuel plants at full rating, with storage of excess power in the form of readily available pumped hydro. Other post-generation options such as batteries, do not yet exist on utility scale. Usually the capacity of nuclear and high efficiency fossil fuel plants is adequate to meet only the minimum or base load power demand. In such cases, peak power demand is met mainly by use of quick response fossil fuel plants which generally are of relatively low efficiency.

Once the availability of major solar thermal power becomes a reality, the energy storage problem becomes much more severe. We can expect that the solar energy will be used both for process heat and electrical power generation. It becomes necessary to match the day-only collection of solar energy to both the requirement for steady energy for industrial processing and also to the requirement for on-demand time-varying energy for the utility grid. The value of the solar energy is significantly increased if the storage is adequate to permit displacement of the inefficient generators which supply the power grid during peak loads.

There are more options for storage of solar power than for storage of electricity after generation. Since solar thermal energy is made available to the power generating facility as heat (or chemicals convertible to heat), it becomes possible to store the energy as heat, prior to

conversion to electricity. Once heat energy is converted to electricity, options are much reduced, with mechanical (e.g., pumped hydro, compressed air, etc.) and batteries the only options. These latter options appear to be much more expensive than the thermal storage option.

In the long run solar thermal power will be used to produce high energy chemicals and fuels. Complex chemical engineering processes work best with a steady controllable heat supply. Heat storage then assumes additional importance as a means of interfacing the day-only solar energy collection process with the continuous processes most likely to be used in fuel manufacture.

Chemical storage is an alternative to thermal storage for solar thermal power systems. Indeed the most promising concept for collection of solar thermal power on large scale is to use chemical reactions to capture the solar thermal power by converting the collected energy into chemical energy prior to transport.<sup>(3-6)</sup> The collected energy is then delivered to a power generating facility by completing a closed cycle chemical energy transport loop to a power generating facility. Storage of the product chemicals is an attractive possibility.<sup>(7)</sup> However, if the collected chemicals are stored as liquids, massive amounts of heats of condensation and evaporation must be alternately collected and made available to avoid inefficiencies of the order of 40%.<sup>(3)</sup> On the other hand, if the chemicals are stored as gases at transport pressure, storage volumes of the order of 40 X those required for thermal storage are required. Thermal storage appears to have an advantage in more easily providing quickly available output energy in the form of superheated steam. However, a mix of chemical and thermal storage looks very attractive. Such a mix should be considered as a means of meeting long-term storage demands. These points are addressed more quantitatively in Appendix A.

Although the storage technologies described in this report appear especially applicable to storage of solar energy, they are also suitable for storage of any energy form convertible to high temperature heat. Such systems may be particularly useful when there is a short time requirement for meeting a heavy duty load. For example, the first energy storage boiler tank, which is electrically energized, will have a nominal rating of 150 kWt, nevertheless, without special design it is expected to be able to deliver energy at a peak rate of close to 1000 kWt. Wherever the value of having a readily available supply of stored energy justifies the cost, thermal energy storage systems based on containerized salts should be considered.

## 2. Scaling the Problem

The going size of commercial power plants is of the order of 1000 MWe. To provide 24 hours of energy storage to operate such a power plant, assuming 33% thermal conversion efficiency, requires a storage capacity of 72,000 MWht, or  $2.6 \times 10^{14}$  J. The storage capacity of the salt eutectic selected for initial work ( $\text{MgCl}_2$ , NaCl, KCl) is 240 kJ  $\text{kg}^{-1}$ . Thus to meet the stated storage requirement, requires the use of  $1.1 \times 10^6$  T (metric tons) of salt. One million tons per year is the output of a moderately large coal mine. The point is: material tonnages are large. Use of naturally available substances which require minimum processing is necessary if storage costs are to be acceptable.

## 3. Raw Material Availability

It is our expectation that, assuming suitable maintenance, thermal energy storage facilities with almost infinite operating life will eventually be developed. Hence, a large size energy storage facility can be thought of as a regional asset, comparable to a dam or pumped hydro-electric facility. Addition of incremental capacity at a rate of 72,000 MWht per year could be a reasonable regional rate of development. To meet this need, material must be made available

at a rate of  $10^6$  T per year. Salt materials found in evaporite and brine deposits are readily available to meet such requirements. Known world deposits and production rates are listed below.<sup>(2)</sup>

TABLE 1  
Salt Reserves

<u>Salt</u>	<u>Known World Deposits</u>	<u>1970 or 1971 U.S. Production</u>
KCl	$10^{11}$ T	$2.7 \times 10^6$ T yr <sup>-1</sup>
NaCl	"Virtually Unlimited"	$45 \times 10^6$ T yr <sup>-1</sup>
Na <sub>2</sub> CO <sub>2</sub> Equiv.	$4 \times 10^{10}$ T	$2.5 \times 10^6$ T yr <sup>-1</sup>
CaCl <sub>2</sub> *	$10^9$ T in Tachyhydrite	
MgCl <sub>2</sub> **	$10^9$ T in Tachyhydrite	
Na <sub>2</sub> SO <sub>4</sub>	$3 \times 10^9$ T	$0.7 \times 10^6$ T yr <sup>-1</sup>

\*"Wells could almost certainly supply domestic needs for at least 100 years."<sup>(2)</sup>

\*\*"For practical purposes ... magnesium compounds in brines and sea water are unlimited, and bedrock resources are large."<sup>(2)</sup>

As stated in *United States Mineral Resources*, for these evaporite commodities "price is determined largely by the cost of transporting the commodities to market." Major sources for Na<sub>2</sub>CO<sub>3</sub> and NaCl are internal drainage deposits at Searles Lake in California, and buried internal drainage evaporite lake beds in Southwestern Wyoming. NaCl, KCl, CaCl<sub>2</sub>, and MgCl<sub>2</sub> are derived from salt beds or brines of marine origin with major deposits in NM, CO, UT, and AZ. The largest known deposits of KCl are in Saskatchewan, Canada. In conclusion, selected TES eutectic systems based on the indicated salts have an adequate resource base. Transportation to user site is the major cost consideration other than processing.

#### 4. Processing Costs and Transportation

For large scale energy storage, we are currently considering three eutectic mixes:<sup>(8)</sup> (MgCl<sub>2</sub>, NaCl, KCl) MP = 385°C; (NaCl, CaCl<sub>2</sub>) MP = 500°C;<sup>(9)</sup> (NaCl, Na<sub>2</sub>CO<sub>3</sub>) MP = 638°C. Processing problems differ significantly for each of these eutectics. The only eutectic



with which we have experience is  $\text{MgCl}_2$ ,  $\text{NaCl}$ ,  $\text{KCl}$ , which is probably the most difficult to process because of the strength with which  $\text{MgCl}_2$  clings onto  $\text{H}_2\text{O}$ . Water must be completely driven off the  $\text{MgCl}_2$  eutectic before it is containerized if corrosion is to be avoided. (Corrosion of damp salt is self-limiting in that it involves  $\text{HCl} + \text{metal} \rightarrow \text{metal chloride} + \frac{1}{2} \text{H}_2$ . If slightly damp salts are used,  $\text{H}_2$  must be vented until corrosion ceases.) So-called commercial anhydrous  $\text{MgCl}_2$  contains significant  $\text{H}_2\text{O}$  ( $\sim 2\%$ ). When a mix containing commercial anhydrous  $\text{MgCl}_2$  is melted for the first time, much, but not all, of the chemically bonded  $\text{H}_2\text{O}$  is released as  $\text{HCl}$ . Moreover, even if the melt is subsequently heated to above  $500^\circ\text{C}$ , some of the  $\text{H}_2\text{O}$  is still retained. On laboratory scale this residual  $\text{H}_2\text{O}$  is effectively removed by inserting aluminum or magnesium strips into the salt melt. The metal is attacked by the acid salt "hydrate". After a while bubbling ceases and a dry salt is obtained. Once dry, the molten salt can be contained in mild steel or aluminum containers. Magnesium salts produced for the magnesium metal industry are much drier than commercial "anhydrous" salts. Magnesium salt fluxes are produced by melting salt mixes in continuous-pour furnaces, producing a product which is about as dry as the laboratory chemically dried material. In the continuous feed furnaces melting is carried out by passing an electric current through the salt mix. Undoubtedly residual  $\text{H}_2\text{O}$  is destroyed by electrolysis.

As regards the other eutectic mixes, processing of  $\text{NaCl}$ ,  $\text{CaCl}_2$  eutectic mixes should involve little more than melting of the salt mix, since  $\text{H}_2\text{O}$  is less tenaciously held by  $\text{CaCl}_2$ , but this speculation has not been tested. Processing of  $\text{NaCl}$ ,  $\text{Na}_2\text{CO}_3$  requires heating of the trona component ( $\text{Na}_2\text{CO}_3 \cdot \text{NaHCO}_3 \cdot 2\text{H}_2\text{O}$ ) to drive off excess  $\text{H}_2\text{O}$  and  $\text{CO}_2$ . Again speculating, it might be possible to carry out the first melting of the  $\text{NaCl}$ ,  $\text{Na}_2\text{CO}_3$  salt mix in the final storage containers assembled in the final storage site. Since some of the trona beds contain halite as an impurity, selection of beds to be mined could eliminate the requirement for mixing of pure materials.

Returning to consideration of the  $\text{MgCl}_2$ ,  $\text{NaCl}$ ,  $\text{KCl}$  material, there is no very good way of estimating costs. Values of the raw chemicals are given in the U.S. Fact Book.<sup>(10)</sup> Current prices are available from suppliers. Processing costs, however, cannot be properly estimated from the magnesium flux industry, since flux tonnages are too low. Costs estimated for furnace processed salt, given by Rossborough, (Appendix B), assuming a production rate of 20,000 tons per year are  $370 \text{ \$ ton}^{-1}$  F.O.B. plant site. In kWh storage equivalent, the salt cost becomes  $6.1 \text{ \$ kWh}^{-1}$ . This value is based on a heat-of-fusion of the  $\text{MgCl}_2$ ,  $\text{NaCl}$ ,  $\text{KCl}$  salt eutectic of  $240 \text{ cal gm}^{-1}$ , as measured by Dynatek. See Appendix C.

A more optimistic and probably more realistic value for the processing cost is derivable from the energy required to dehydrate  $\text{MgCl}_2 \cdot 6\text{H}_2\text{O}$  and to melt the salt eutectic. This energy should be the dominant nontransportation item for a large continuous processing plant. If we charge the energy at the cost of electrical heat, we are overestimating the cost of salt preparation, since the bulk of the dehydration can be carried out using low grade heat. Alcohol dehydration, or  $\text{NH}_4\text{Cl}$  cycles might still further reduce energy usage. The results of the analysis are given in Appendix B, which leads to a value of  $83 \text{ \$ ton}^{-1}$ . In kWh storage equivalent, the salt cost becomes  $1.37 \text{ \$ kWh}^{-1}$ .

The processing costs for  $\text{CaCl}_2$ ,  $\text{NaCl}$  eutectic and  $\text{NaCl}$ ,  $\text{Na}_2\text{CO}_3$  eutectic are expected to be substantially below those of  $\text{MgCl}_2$ ,  $\text{NaCl}$ ,  $\text{KCl}$  eutectic. Large tonnage salt costs without transportation are estimated at  $35.4 \text{ \$ ton}^{-1}$ . The basis for the estimates are given in Appendix B.

Salt transportation costs were obtained in 1976 from Union Pacific. Costs are determined by the freight rate structure. Costs were 1.5¢ per ton-mile for transportation from a salt resource region to a salt deficient region. Salt transportation costs for a 1500 mile trip were

0.37 \$ kWh<sup>-1</sup>. Inflating at 10% per year gives a 1979 cost of 0.47 \$ kWh<sup>-1</sup>. However, for the build-up of national facilities in a major solar energy region, it might be practical to use pipeline brine transport, followed by evaporation on a salt flat. The cost impact of this concept has not been assessed.

#### 5. Initial Costs of Storage Systems Based on MgCl<sub>2</sub>, NaCl, KCl Eutectic

In the preceding section and in Appendices B, G and F, we have addressed major elements of storage system costs for systems based on MgCl<sub>2</sub>, NaCl, KCl eutectic combined with m-terphenyl heat transfer fluid. Additional, but less-costly elements are the containment tank, the tank foundation, the internal pipings forming the boiler and superheater, load-bearing insulation underneath the tank, loose insulation around the sides and top of the tank, the terphenyl circulation pump and the feedwater pump for the boiler. Table 2 shows these costs on a per kWh basis.

It is believed that the costs indicated in Table 2 could be lowered with further effort, particularly as regards cans, loose insulation, foundation and possibly the containment vessel. In contrast the cost assigned to heat transfer fluid is based on the use of m-terphenyl, which may not be satisfactory as regards life. It may well be possible to obtain a suitably long life test fluid for the MgCl<sub>2</sub>, NaCl, KCl eutectic, as suggested in Appendix G. Alternatively energy could be stored in an energy storage boiler tank at 287°C using the more expensive NaOH, Na<sub>2</sub>CO<sub>3</sub> eutectic<sup>(11)</sup> combined with the adequately durable, low cost biphenyl heat transfer fluid.

TABLE 2  
 Cost Estimate for Energy Storage Based on MgCl<sub>2</sub>, NaCl,  
 KCl Eutectic Costs per kWh<sup>(1)2</sup> (\$ 1979)

Item	Proof-of-Concept Tank	At Build-up Rate 1200 MWht per year
Anhydrous Eutectic	16.48	1.37 <sup>(2)</sup>
Containers	9.41	2.20 <sup>(3)</sup>
Heat Transfer Fluid	23.04	3.70 <sup>(4)</sup>
Salt Transportation	1.65	0.49 <sup>(5)</sup>
Containment Vessel	27.50	1.20 <sup>(6)</sup>
Foundation	0.58	0.76 <sup>(7)</sup>
Load Bearing Insulation	0.23	0.04 <sup>(8)</sup>
Loose Insulation	1.23	0.15 <sup>(9)</sup>
Piping—Including Boiler, Superheater	5.49	0.24 <sup>(10)</sup>
Pump for Heat Transfer Fluid	2.03	0.05 <sup>(11)</sup>
Feedwater Pump	0.46	0.02 <sup>(12)</sup>
TOTAL of Big Items	88.10	10.22 $\times 1.4375 = \frac{\$14.7}{\text{kWh}_t} \times \frac{1 \text{ kWh}_t = \$49}{13 \text{ kWh}_e} = \frac{\$49}{13 \text{ kWh}_e}$
Allowance for Misc. and Construction, (30% of above)	26.43	3.07
<b>TOTAL</b>	<b>114.53 \$ kWh<sup>-1</sup>(13)</b>	<b>13.29 \$ kWh<sup>-1</sup></b> $\times \frac{\$49}{13 \text{ kWh}_e}$

(1) All costs based on eutectic heat-of-fusion measurement 240 kJ kg<sup>-1</sup> (Appendix C).  
 (2) Based on quotes for raw salts with processing costs estimated as per Appendix B. Rossborough estimate is 6.1 \$ kWh<sup>-1</sup>.  
 (3) Based on 1975 can prices of the Freund Can Co., inflated 10% per year. See Appendix G.  
 (4) Based on m-terphenyl fractionated within tank from a starting fluid of thermal 88, Appendix F. Initial cost only.  
 (5) 1500 miles. Cost inflated 10% per year from 1976 quote.  
 (6) Based on use of 66' tanks providing 444 MWht storage and weighing 241 tons. Cost of steel and fabrication estimated at 1200 \$ ton<sup>-1</sup>.  
 (7) 7324 tons of salt + 241 tons steel  $\Rightarrow$  4422 lbs. ft<sup>-2</sup> based on slab 2 feet thick of sufficient area to reduce ground loading to 1000 lb ft<sup>-2</sup>. Cost of doubly reinforced concrete taken at \$300 per cu. yd.  
 (8) Based on 24" of Foamglas.  
 (9) Based on 40" of Dacotherm sodium silicate insulation.  
 (10) Ratio of piping cost to tank cost assumed same as for proof-of-concept tank.  
 (11) Three pumps (500 gpm each @ 100' head) with 20 hp motors, Lawrence Pump and Engine Co., Lawrence, MA.  
 (12) Two triplex pumps plus relief valve including motors, F.E. Meyers, Ashland, OH.  
 (13) Actual cost several times this value due to expensive site preparations, development costs and costs associated with electrical heater input system.

### III. HEAT-OF-FUSION ENERGY STORAGE TECHNOLOGY

#### 1. Thermal Conductivity-Rationale for Containerizing Salts

A major characteristic of salt eutectics is their poor thermal conductivity. Maru et al.<sup>(12)</sup> give a thermal conductivity of  $.87 \text{ WM}^{-1}\text{K}^{-1}$  ( $2 \times 10^{-3} \text{ cal cm}^{-1}\text{s}^{-1}\text{K}^{-1}$ , or  $0.5 \text{ BTU/hr-ft-}^\circ\text{F}$ ) for the conductivity of chloride salt mixes at the melting point. Information on conductivity of solid eutectics, which are masses of small crystals, is less well defined. Marv et al.<sup>(2)</sup> show in their Table 2 that the conductivity of the solid is generally slightly higher than that of the melt. In subsequent calculations we use the Maru et al. value for typical chloride eutectic melts.

The important point to note is that solid eutectics are all good thermal insulators. Where it is necessary to flow heat through significant thicknesses of frozen salt, it is necessary to use very large heat transfer areas if excessive temperature drop is to be avoided. One means of obtaining very large heat transfer areas is to contain the salt in cans of large aggregate area. This requirement for large areas of heat transfer provides the rationale for storing energy as heat-of-fusion in containerized salts.

#### 2. Input—Output Considerations

An energy storage device must have means for introducing energy and means for withdrawing energy. In heat-of-fusion storage devices the energy is introduced as heat at a temperature slightly above the melting point of the storage medium. With solar thermal power systems, the heat used for energy input can be provided to energy storage by several means: (1) exothermic chemical reactions at the lower temperature end of a closed cycle thermochemical energy transport loop, (2) conduction from a heat transfer medium which is pumped through a solar heated system,<sup>(13)</sup> or (3) condensation of a working fluid previously boiled in a solar collector. For test purposes, or for applications in which the storage system is used to provide

high peak load available power heat input can be provided by electrical resistive heating, as in the proof-of-concept storage tank currently being built, or by burning of fuels. Energy is withdrawn in current designs as high pressure steam, generally as superheated or reheated steam. Alternatively, heat could be withdrawn by boiling an organic fluid in a Rankine system, such as toluene or biphenyl. When the end use of the collected heat is to power a chemical processing system, energy removal may be by delivery of heat directly to the pipes or reaction vessels making up the chemical processing equipment.

### 3. Internal Heat Transfer

Three main technical problems in energy storage units using containerized salts as the energy storage medium are: (1) the problem of transferring heat from the energy input surfaces during charging (2) the problem of distributing the heat uniformly to the surfaces of all the storage cans and (3) the problem of transferring the heat from the surfaces of the energy storage containers and delivering it to boiler tubes, or other energy output tubes during discharge. All heat transfer must be done with minimum temperature drop. The basic problem is shown in Figure 1.

Two methods of accomplishing the above heat transfer functions have been identified, namely (1) evaporation-condensation of a heat transfer fluid, i.e., the technique used is the home "pressure cooker", and (2) radiation coupling between an extended network of heat pipes and the salt cans, with the heat pipes in turn conductively coupled to the input heat source and the output heat load. The preferred solution depends on energy storage temperature. These two solutions to the internal head transfer problem in turn lead to two types of energy storage tanks, i.e., the "energy storage boiler tank" and the "radiation coupled energy storage tank." Both types of energy storage tanks can be used for interfacing energy storage to boiler and/or

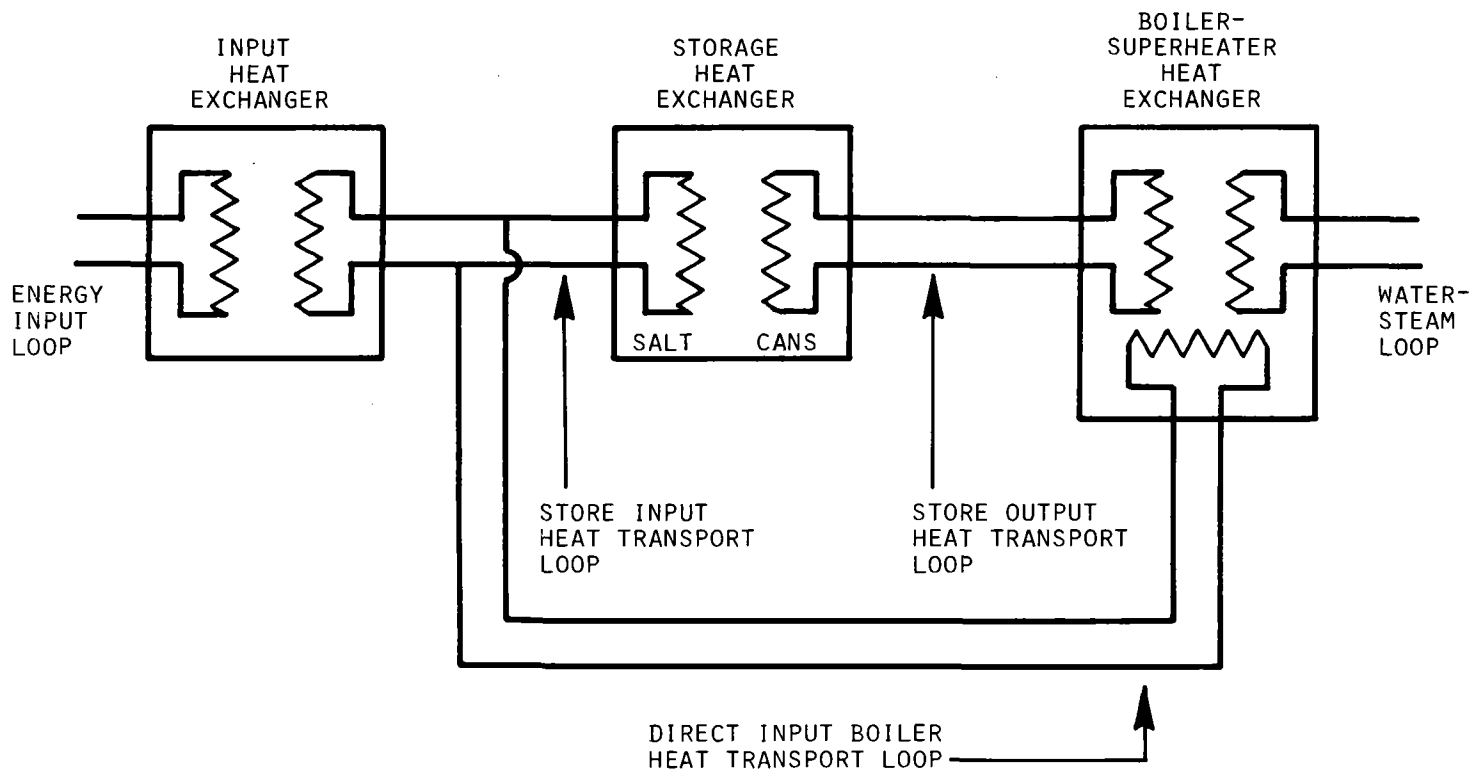

CHUBB, NEMECEK, AND SIMMONS

Fig. 1 — Heat exchange flow chart showing the required heat transfer links inside energy storage boiler/super-heater tanks. First, energy must be withdrawn from the energy input source and delivered simultaneously both to containerized salts for storage and to the boiler-superheater assembly for energy delivery to a demand load. As interfaced to a Solchem solar energy collection system, the input heat device is an exothermic chemical reactor. The second heat transfer function is removal of stored energy from the molten salt energy storage medium with subsequent delivery of the energy to the boiler-superheater. This second transfer loop is the only loop active during no-energy input periods. The heat transport mechanisms used differ between the "Energy Storage Boiler Tank" and the "Radiation Coupled Energy Storage Tank," as described in Table 3.

superheater functions. These storage tanks are characterized by the means selected for internal heat transfer as shown in Table 3. Their construction and characteristics are described separately in the paragraphs which follow.

TABLE 3  
Heat Transfer: Energy Storage Boiler Tank and Radiation Coupled Energy Storage Tank

ITEM	ENERGY STORAGE BOILER TANK	RADIATION COUPLED ENERGY STORAGE TANK
Input heat exchanger	Boiling of heat transfer liquid, or conduction to forced-circulation heat transfer liquid followed by flash evaporation.	Conduction to lower ends of potassium heat pipe, possibly through liquid metal intermediary.
Store input heat transfer loop	Transport of vapor of heat transport fluid driven by weak pressure gradients in pressurized tank. Loop closed by liquid return under gravity.	Transport of potassium vapor driven by pressure gradients within heat pipe tubes, followed by condensation of potassium vapor on heat pipe walls, followed by liquid return driven by surface tension gradients on tube walls $\pm$ gravity.
Storage heat exchanger	(input) Condensation of vapor or heat transfer fluid on salt can surfaces.  (output) Evaporation of liquid heat transfer fluid from salt can surfaces. Liquid resupplied by pumped circulation loop.	(input) Radiation from heat pipe tubes to salt can surfaces.  (output) Radiation from salt can walls to heat pipe tubes
Store output heat transport loop	Transport of vapor of heat transfer fluid driven by weak pressure gradients in pressurized tank. Loop closed by liquid return under gravity.	Transport of potassium vapor driven by pressure gradients within heat pipe tubes, followed by condensation, followed by liquid return driven by surface tension gradients on tube walls $\pm$ gravity.
Boiler-superheater heat exchanger	(input) Condensation of vapor of heat transfer fluid on boiler and superheater tubes  (steam output) Conduction to boiling water or flowing steam.	(input) Conduction from heat pipe tubes to boiler and/or superheater tubes, possibly through liquid metal intermediary.  (steam output) Conduction to boiling water or flowing steam.



## a. Energy Storage Boiler Tank

The energy storage boiler tank depends on evaporation-condensation of a heat transfer fluid for heat transfer. The storage tank is made in the form of an insulated pressure tight vessel, as shown in Figure 2. (Also see frontispiece). The bottom of the tank is filled with a single-boiling-point heat transfer liquid, which covers the heat input tubes. The heat input tubes provide the interface through which heat is delivered to the tank. The heat input tubes are heated by such means as, (1) circulating a high temperature liquid through the tubes, (2) stimulating an exothermic reaction to occur in a chemically reactive fluid circulated through the tubes, or (3) heating the tubes electrically with resistive heaters. Regardless of the means used to heat the heat input tubes, the resultant heat energy is distributed throughout the tank by condensation of the heat transfer fluid which fills the bottom of the tank. The tank itself is largely filled with stacked containers filled with salt. All gases and vapors other than those associated with the heat transfer fluid are permitted to be exhausted from the tank as the heat transfer fluid vapor displaces them during warm-up. Once pure heat transfer fluid vapor fills the tank, condensation of vapor occurs on all surfaces having a lower temperature than the boiling surface of the heat transfer liquid. This method has been shown capable of maintaining uniform temperatures throughout a test chamber filled with canned salt. In laboratory tests, full salt melting (60 lb) was achieved in about five hours with the temperature of the heat transfer liquid never exceeding the melting point of the salt by more than 12°C. (Heat transfer fluid; m-terphenyl; salt; MgCl<sub>2</sub>, NaCl, KCl eutectic.) Operation is directly analogous to that of the home pressure cooker, which uses water as the heat transfer fluid, instead of m-terphenyl, and distributes heat at 120°C instead of 395°C.

Energy removal from the energy storage boiler tank is also by evaporation-condensation. To remove energy from the salt cans, thereby freezing the enclosed molten salt, it is necessary

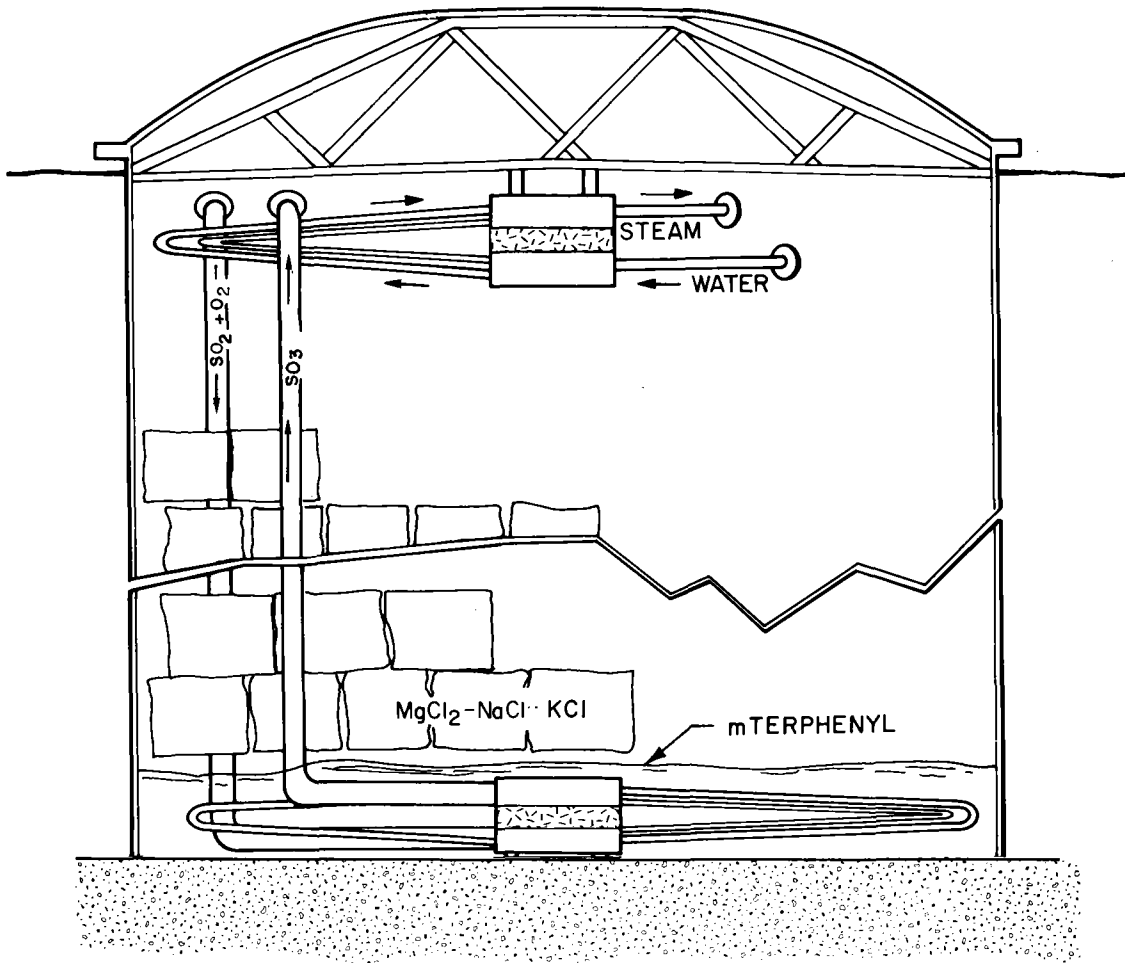

Fig. 2 — Energy storage boiler tank designed for energy storage at 385°C. Operation of the tank is described in figure caption of "Frontispiece."

to evaporate liquid from the surfaces of the cans. The liquid film evaporated from the sides of the cans must be restored by spraying the cans with recirculated liquid heat transfer fluid. Thus a pumped heat transfer liquid recirculation loop with shower-head spray units is provided for energy storage tanks operating on this principle.

Energy is removed from the tank as a whole by means of a condensation boiler and/or superheater. Thinking in terms of boiler operation, heat is delivered to the outside wall of the boiler by condensation of heat transfer fluid vapor. Heat flow is limited by conduction of heat through the liquid film coating the boiler tubes. The operation of such a boiler is described in Appendix D.

Long-term operation of an energy storage boiler tank requires use of salts melting at the desired temperature and a boiling fluid that either has long-term stability or can be continuously cleaned up as part of the maintenance procedure. A practical fluid for storage at temperatures above 385°C has not been identified, although it is by no means ruled out that a suitable high temperature fluid will be found. For this reason the energy storage boiler tank concept is currently limited to temperatures below approximately 385°C. It is believed that energy storage boiler tanks operating at lower temperature can be built so as to provide very long operating life.

#### b. Radiation Coupled Energy Storage Tank

For energy storage at higher temperature, use of radiation for heat transfer between salt cans and a network of heat pipes is a practical means of carrying heat to and from the salt cans. This approach requires a large area of heat pipe surface. The aggregate heat pipe surface, however, can be a factor of 10 or less than the surface area of the salt cans. The concept is shown in Figure 3. The individual heat pipes carry only small amounts of heat, hence need only be of

*See - what is the story on this ???*

# Salt-filled tank supplies heat for high-pressure steam

*Prototype container is expected to deliver energy at output rates up to 500 kW*

David J. Bak, East Coast Editor

Washington, DC—Construction is starting on a prototype energy storage tank that is designed to store about 2000 kW-hr of thermal energy. Filled with 60,000 lb of eutectic salt, the container stores energy as "heat of fusion" and expects to deliver this energy at output rates up to 500 kW. Developed by Dr. Talbot Chubb of the Naval Research Lab., the tank operates like a home pressure cooker, but at a higher temperature and on a massive scale.

The experimental container, mea-

suring 10 ft in dia and 12 ft high, is constructed of steel and fitted with a flanged dome top. The tank sits on a foamglass base, is insulated with vermiculite and encased in a concrete shell.

Piercing the walls at the bottom of the tank are power lines connected to electrical heaters. The containerized eutectic salt rests on a grate located just above the heaters. Each can of salt measures 40 inches high by 4.0 inches in dia; they occupy the bulk of the interior volume of the tank. The dome of the tank contains

the steam boiler tubes and superheat assembly.

Covering the heaters and filling the bottom of the tank to a little below the grating is a pool of metaterphenyl. This acts as the heat transfer fluid. Once heat is introduced to the tank via the electrical heaters, the inside of the tank fills up with vapor from the fluid. As the vapor pressure increases, the vapor condenses on any cooler surfaces (i.e., the surfaces of the salt canisters). This brings the whole system up to the desired temperature (725F) and melts the salt. With this design, heat can be stored cumulatively for long periods of time.

When steam is desired, water is pumped through the boiler tube assembly at the top of the tank. Terphenyl vapor condenses on these tubes, boiling the water and

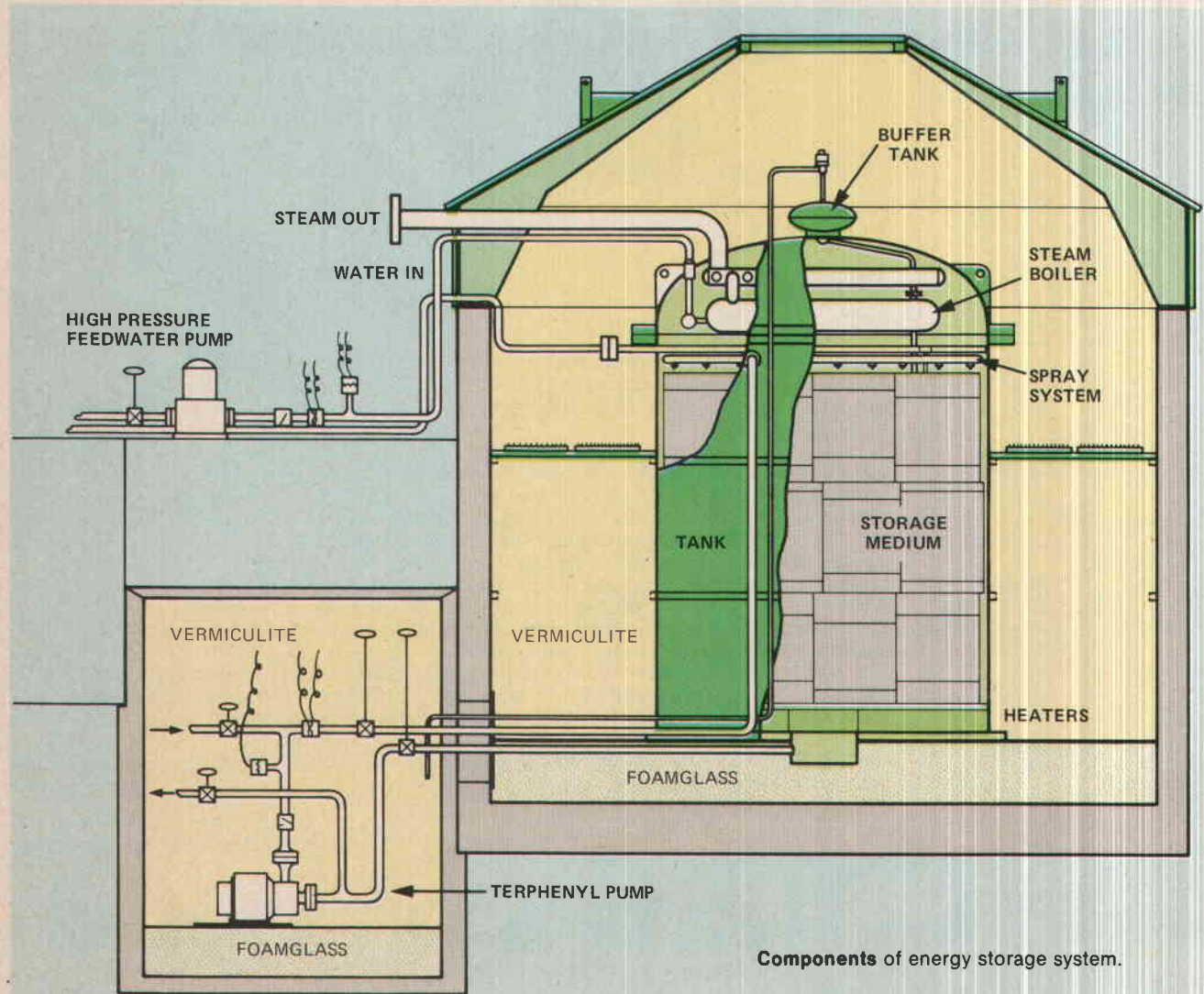

**Components of energy storage system.**



# ANOTHER MYTH EXPLODED:

**All solenoids are NOT created equal.**



No. 28  
Solenoid

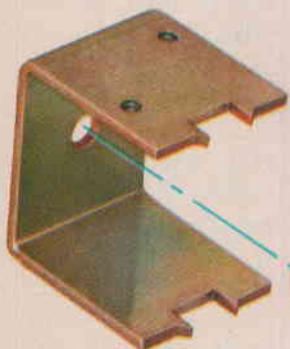

**New Uni-Guard II molded bobbin and coil covers** are Valox® 420 SE-O... to meet or surpass all U/L and CSA component recognition requirements; also meet tough U/L flammability spec 94V-0.

**New Uni-Guard II construction** minimizes wear by holding concentricity between plug and plunger... and minimizes double seating.

**New Uni-Guard II coil cover** gives snug, protecting fit, yet leaves space for addition of thermal cutouts or diodes.

**Dual endplates** on model shown improve mechanical strength and magnetic efficiency.

**Bright Nickel plated plunger** for low friction, low corrosion resistance.

**Lugs** are press fitted and ultra-sonically welded to bobbin to withstand eight pound pull test.

**Endplates** are swage formed and staked to field piece to provide continuous magnetic flux field for most efficient operation.

**Only Guardian solenoids have new Uni-Guard® II molded bobbin and coil covers** that give you savings of up to 25%... with at least 25% longer life. How long? Up to 5 million operations. This new construction is now available on nearly all Guardian box frame and U-frame solenoids. Including pull type, push type and solenoid switches. All have .187" or .110" QC lug or solder lug termination for easier, faster, less expensive installation. And Guardian has more types available from stock than anyone else.

Variations and options? Get them from Guardian. Return springs, plunger configurations, anti-bottoming or silencers, voltages, termination, mounting, coil finishes... you spec it and Guardian's ready to produce it.

**Let the Guardian Angel show you why Guardian is No. 1 in solenoids.** Send for your free copy of this 72 page catalog.



This mark indicates recognition under the component program of Underwriters Laboratories, Inc.

See Us At Booth #1310  
Design Engineering Show



# GUARDIAN®

GUARDIAN ELECTRIC MANUFACTURING CO.

1550 West Carroll Ave., Chicago, Illinois 60607 • 312/243-1100

Circle No. 478



superheating the resultant steam. With an initial energy input of 150 kW, the system will produce about 500 kW of steam at 800 psi. In order to maintain vapor pressure in the tank when the electric heaters are turned off, a small circulating pump draws from the pool of terphenyl and sprays the fluid over the canisters.

Because the tank is a prototype, it uses the electric heaters described. However, thermal input to anticipated large commercial storage tanks would be supplied from other sources of high temperature heat such as nuclear reactors or fossil fuels. In a solar application, the thermal input would be provided by an energy collection and transport system using closed-cycle chemical reactions. The use of such a system in conjunction with the energy storage-boiler tank is currently being developed.

Additional details . . . Write Naval Research Lab., Washington, DC 20375.

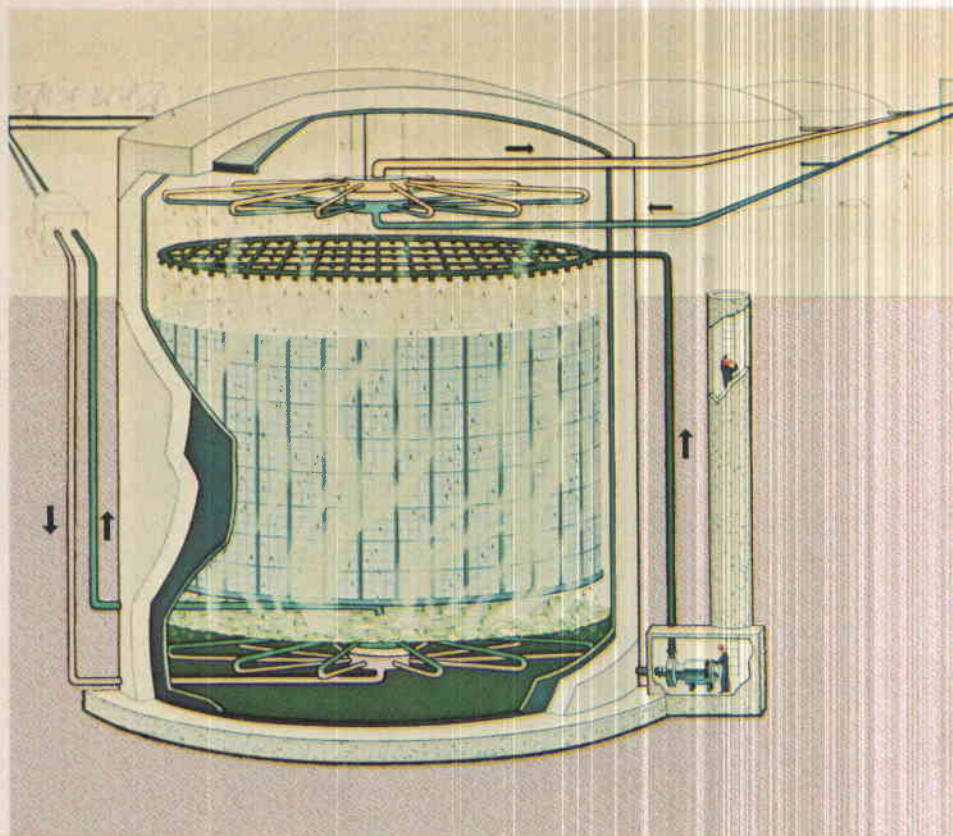

Energy storage boiler tank works 24 hours a day with constant supply of energy in form of steam readily available for use. (Drawing by Pierre Mion)

# Rube Goldberg would've loved us.

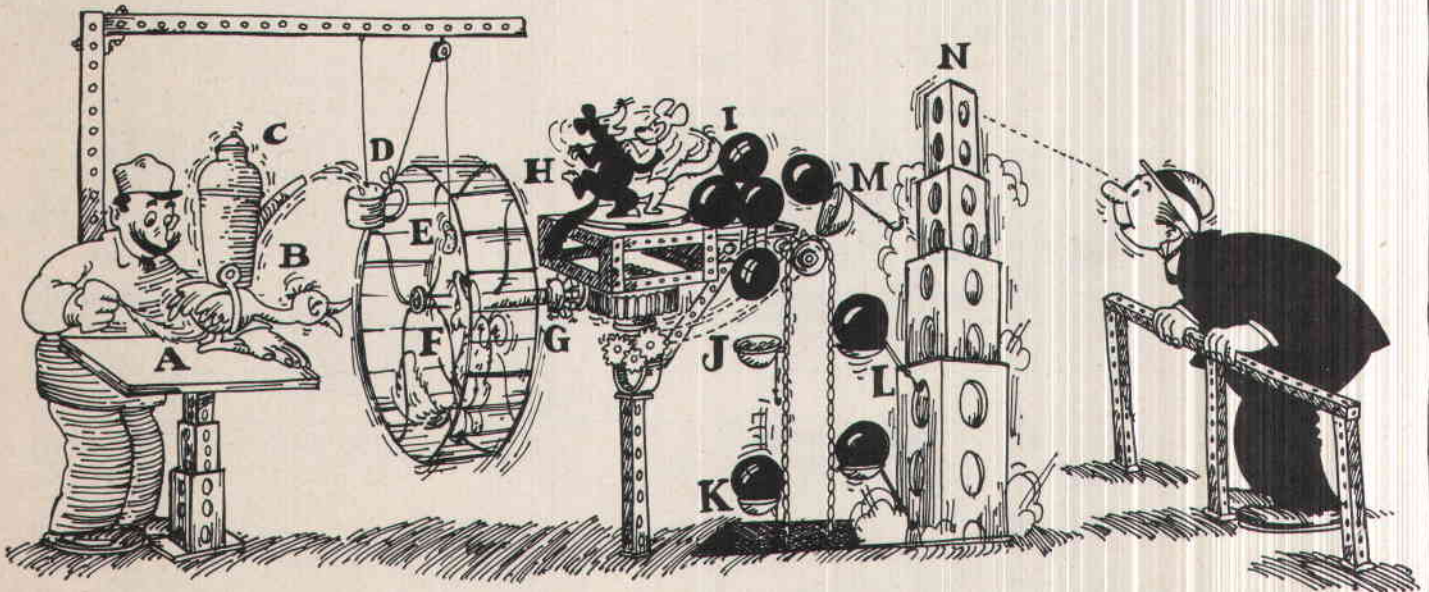

If anyone had design problems, it was Rube Goldberg. And if anyone has solutions, it's the Unistrut Corporation.

Our Telespar® telescopic tubing can support most any contraption. Whether it runs on two mousepower or two thousand horsepower.

You'll find Telespar at any Unistrut Service Center, in

many sizes. With or without perforations, in 10 or 12 gauge. And you'll find more information on Telespar telescopic tubing by writing Unistrut Corporation, Wayne, MI. 48184. Or better yet, call the Unistrut service center nearest you.

**UNISTRUT** Telespar Systems





# Water pump reworked to operate at 600F, 3000 PSI

*'Stellite' on titanium dioxide seals pump housing*

Brian J. Hogan, Midwest Editor

Arvada, CO—Scientists at a southwestern research laboratory wanted to use a standard five-stage centrifugal pump to circulate hot (600F) water through solar collectors. The unit, originally developed for boiler feed service, would help research

personnel test different collector designs.

However, bearing surfaces on the impellers and in the diffuser housing were graphite-impregnated nylon. At 600F, water dissolves most materials including alumina. The

nylon bearings could not be expected to survive in this application.

Also, designers didn't want the pump's motor exposed to hot, corrosive water. So the diffuser housing had to be effectively sealed, and the motor cooled to protect it from the 600F temperatures expected.

Design engineer John C. Bond, Senior Project Engineer at Barber-

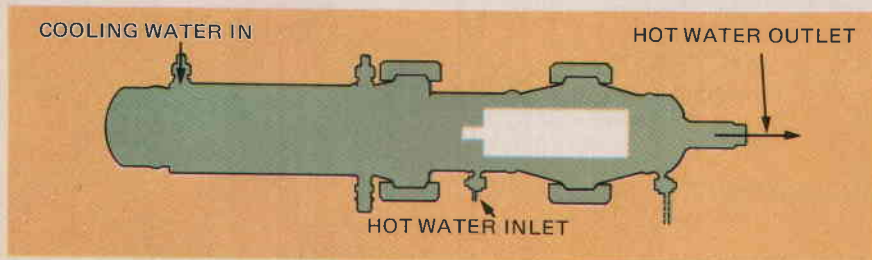

**Use of** carbon-graphite inserts, "Stellite" seals and titanium dioxide coating enables pump to move 600F water.

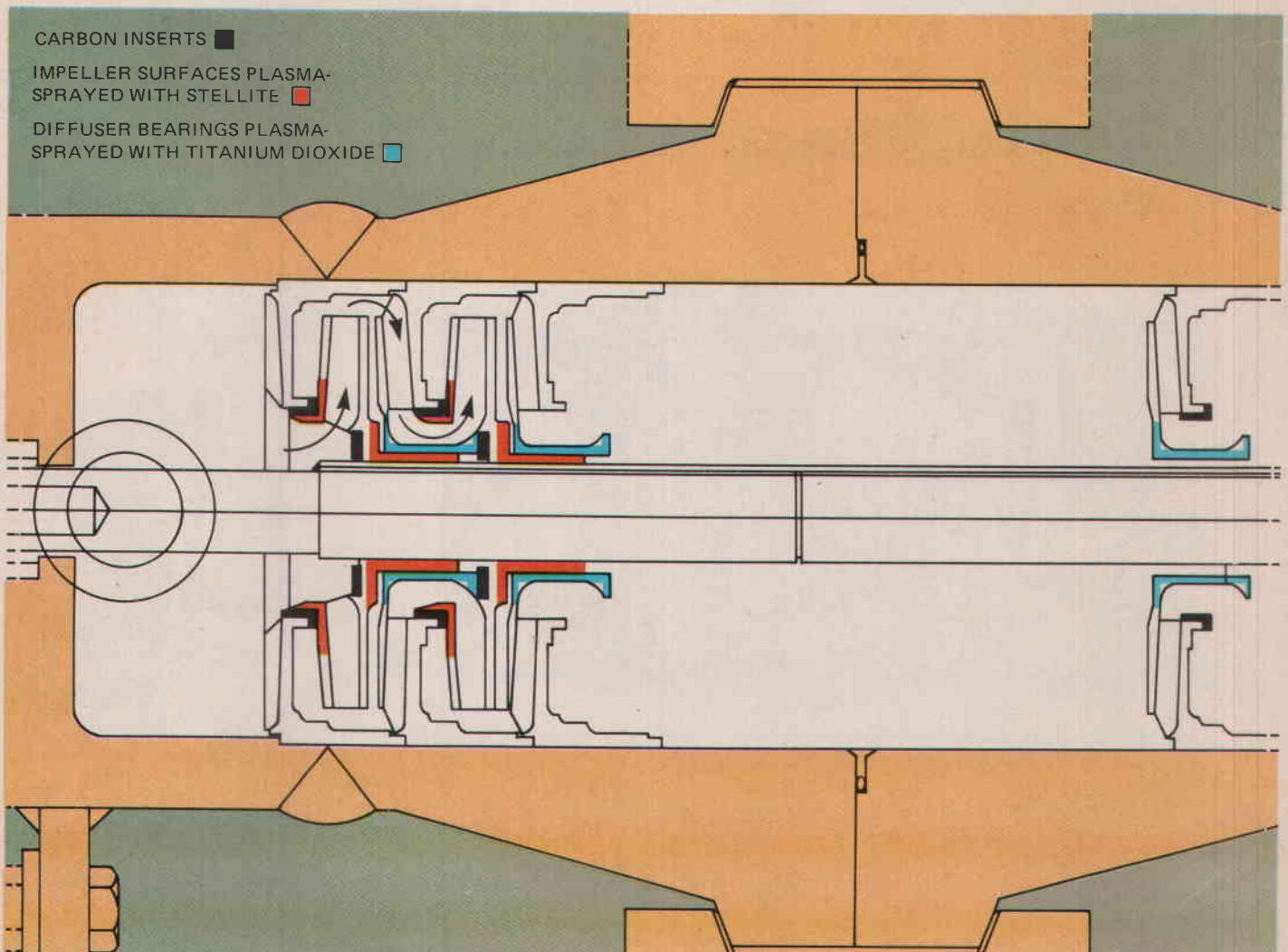

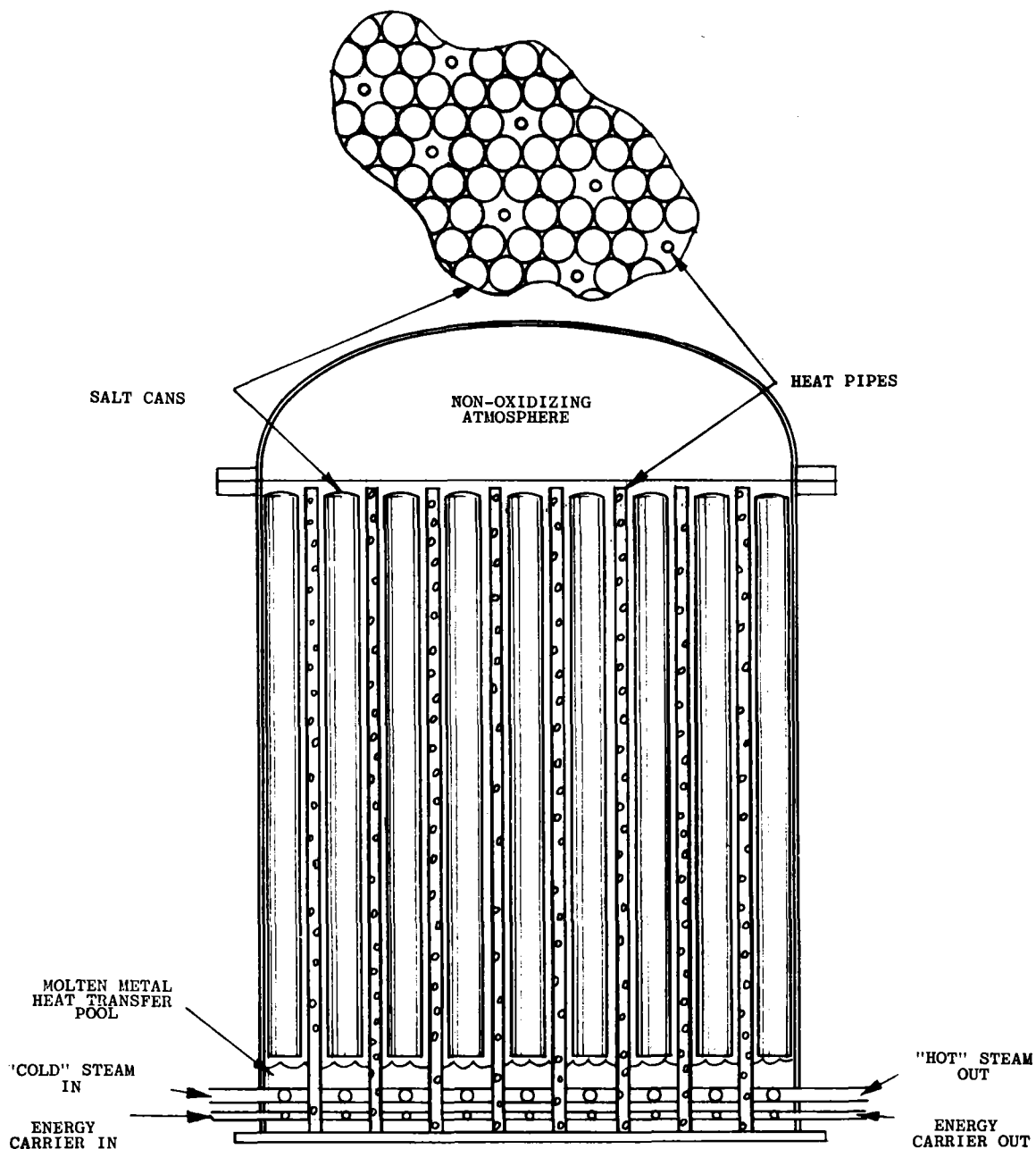

Fig. 3 — Radiation coupled energy storage tank. Energy is stored as latent heat-of-fusion in containerized molten salts. The salt containers are closed-off pipes filled with salt, and largely fill the containment vessel. Heat is delivered, and removed from, the salt containers by radiation coupling to a network of alkali metal vapor heat pipes. Heat transfer between energy input pipes and the alkali metal heat pipes is by conduction through molten metal coupled interfaces. Heat transfer between alkali metal heat pipes and the energy output boiler/superheater is also by conduction through molten metal coupled interfaces. The radiation coupled energy storage superheater tank operates at ambient pressure and can be engineered to provide enormous storage capacity in factory size building structures.



the simplest design. The heat pipes could likely be simple steel tubes, treated on the inside to promote wetting. Prior to evacuation and seal-off, a small piece of potassium would be inserted to become the heat transfer medium. Such a network of heat pipes appears capable of distributing heat throughout a large array of cans. Radiation can then provide adequate transfer of heat between heat pipes and cans with  $\Delta T \sim 30^\circ\text{C}$ . Calculated heat transfer rates are shown in Figure E-2 in Appendix E. Convective and conductive heat transfer by means of the gas contained in the storage vessel contributes negligibly to heat transfer. Calculations supporting these statements are also given in Appendix E.

Energy withdrawal from a storage assembly of the above type also makes use of heat pipes. Wetting action is depended upon to deliver alkali metal liquid to all the internal heat pipe surfaces. Heat received by the heat pipes by means of radiation from the salt cans evaporates this liquid metal film. Subsequent condensation delivers the heat to super heater tubes conductively coupled to the cold end of the heat pipe system. If the super-heater tubes are placed above the salt cans, and the heat input pipes below the salt cans, all heat pipes can operate in a gravity assisted mode.

The radiation coupled energy storage tank is especially well-suited for energy storage at high temperature, where radiation is increasingly effective and larger  $\Delta T$ 's for input and output are tolerable. Radiation coupled tanks should have very long operating life. They also have one big advantage over energy storage boiler tanks. They do not require use of a pressure-tight enclosure, hence building-size storage facilities can be constructed. They make use of the least expensive salts. The radiation coupled energy storage tank makes possible very large regional energy storage complexes.

#### IV. ENERGY STORAGE BOILER TANK FOR STORAGE AT 385°C (725°F)

The concept of storing energy as the heat-of-fusion of a salt eutectic in containerized salts is being explored experimentally using the energy storage boiler tank concept. Laboratory work was carried on prior to the construction of a 2 MWht proof-of-concept storage tank. The laboratory studies have thrown light on several areas of concern, and have led to design concepts that avoid identified problem areas. The lab studies have also identified design options which can be utilized if scale-up encounters difficulties. Most of the problem areas relate to the particular material set that has been chosen for the 385°C storage tank; namely, storage in MgCl<sub>2</sub>, NaCl, KCl eutectic and heat transfer by use of m-terphenyl. (m-terphenyl is the most abundant constituent of Therminol 88, which is a mixture of m-terphenyl, p-terphenyl and o-terphenyl.)

##### 1. Potential Problem Areas

###### a. Corrosion

One potential problem area is corrosion; namely, the possibility that molten salt will attack the salt containers limiting their life. The laboratory studies indicate that corrosion is not a problem if the storage salts are thoroughly dried before use and if mild steel is used as the container material. Any etching of the steel cans by the salt results in iron staining of the salt. With dry salts such staining has not been observed after 18 melt cycles. Evidence of internal pitting of the cans is not seen. In contrast rusting of the outside surface of the salt cans during the filling process at the salt plant is extensive. Rusting during preuse storage could be a problem if a dry environment is not maintained.

#### b. Degradation of m-Terphenyl Heat Transfer Fluid

Degradation of the m-terphenyl heat transfer fluid is continuous during the operation of the energy storage boiler tank. Darkening of the fluid combined with a slow build-up of high temperature boiling fractions,<sup>(14)</sup> as observed by gas chromatography, occurs. The seriousness of this degradation over a year's operation was not evaluated quantitatively at NRL, but has been studied de Halas, working with separated terphenyls and by Pinero and Rodriguez working with Gilotherm terphenyl mixes<sup>(15)</sup>. The data are quite discrepant. At NRL m-terphenyl was refluxed in an  $N_2$  atmosphere for 18 months in an evaluation run which was terminated when a rapid rise in boiling point began, and char formation occurred. The final degradation was a runaway process. It is not known what the m-terphenyl replacement rate would have to be to maintain steady operation. However, with the least favorable data degradation is sufficiently slow that no trouble should be encountered in the proof-of-concept demonstration over several months. Lifetime estimates based on de Halas data and on Pinero-Rodriguez data are discussed in Appendix F. Means for heat transfer fluid bleed-off and replacement are being provided.

#### c. Fractionation

An energy storage-boiler tank operates as a fractionation column. If a mixture of liquids is boiled in the bottom of the tank, the vapor that accumulates at the top of the tank is almost purely the vapor of the highest vapor pressure component, i.e., the component with the lowest boiling point. Hence, temperatures at the top of the tank are those corresponding to the boiling point of the highest vapor pressure component, while lower tank temperatures are near to those of the main component, both calculated at tank pressure. This type of fractionation can result in excessive temperature drops occurring during energy input. It is therefore important to use a heat transfer fluid that acts like a single boiling point species. For this reason m-terphenyl, rather than Therminol 88, is used as the heat transfer medium.

If an energy storage boiler tank is fitted with a liquid return buffer tank and bleed valve, it will operate properly with somewhat impure heat transfer fluid, e.g. m-terphenyl fluid containing residual o-terphenyl. High vapor pressure components are collected in the buffer tank, rather than in the main tank, and are periodically bled off. The vented material is collected as a liquid and not dispersed in the atmosphere. With occasional venting, very good temperature uniformity was maintained throughout the laboratory test tank. The total amount of heat transfer fluid removed over six weeks in the course of laboratory test tank operations was a small fraction of the initial heat transfer fluid charge.

#### d. Repurification of Heat Transfer Fluid

During operation of the 2 MWht storage tank now under construction, heat transfer liquid will be continuously withdrawn from a sump in the bottom of the tank and will be sprayed over the salt cans during energy withdrawal periods. An option exists to divert a portion of this flow and to feed it to a fractional distillation column from which the higher vapor pressure fractions could be continuously returned to the heat transfer fluid loop. The lower vapor pressure fractions could periodically be removed for disposal or refurbishment. In this manner unpolymerized m-terphenyl could be maintained within the tank, with make-up fluid added as needed. Such a procedure would duplicate the processing used to obtain our start-up m-terphenyl. This initial charge was obtained from a terphenyl mix by using fractional distillation to separate m-terphenyl from o-terphenyl and p-terphenyl. Thus there should be no difficulty in obtaining satisfactory purification in a continuously operating loop made part of the storage tank system. However in this first demonstration of bulk energy storage in containerized salts, we do not plan to complicate the system by including a fractionating purification loop. Published data on terphenyl pyrolysis rates are quite discrepant. The degradation of heat transfer fluid could impact the cost of energy storage boiler tanks in a significant way if the higher rates reported in

the literature turned out to be correct. If the lower decomposition rates are valid, the problem is not so severe. This problem is addressed in Appendix F.

e. Salt Crusting and Porosity

Laboratory testing has been carried out using salts contained in two types of cans: Cans with no lids and cans with loose-fitting lids. In both cases, hot salt was continuously exposed to terphenyl vapor. Salts in open cans developed a dark porous crust, Figure 4, which built up somewhat in repetitive cycles, causing can overflow in some cases. Material forming the dark crust was largely water-soluble; it is believed to consist of salt grains cemented by minute amounts of carbonaceous material. In the cans with loose-fitting lids, a thinner, lightish crust (Figure 5) was observed after 18 cycles. It is unknown as to whether crust build-up had stabilized, or whether build-up would have continued with more cycling. Salt spillover was not threatened.

A related salt problem was observed in salt that was recycled 18 times. Salt, when first poured into a can, shrinks as it solidifies and forms a dense monolythic block around the walls of the can with a deep internal cavity, Figure 4. Salt that was 18 times recycled in cans with loose-fitting lids solidified as a fairly porous structure largely filling the can as shown in Figure 5. This porous structure is undesirable due to the decreased thermal conductivity expected.

*f. Control ?*

2. Separately Manifoldded, Conductivity Enhanced Cans

The decision was made to build the proof-of-concept 2 MWht energy storage tank using cans with lids in which a hole is punched to permit vapor flow, preventing differential pressure forces. However, the option exists to design salt containers that are separately manifolded to an inert atmosphere, thereby preventing dissociation of heat transfer fluid in contact with the salt.

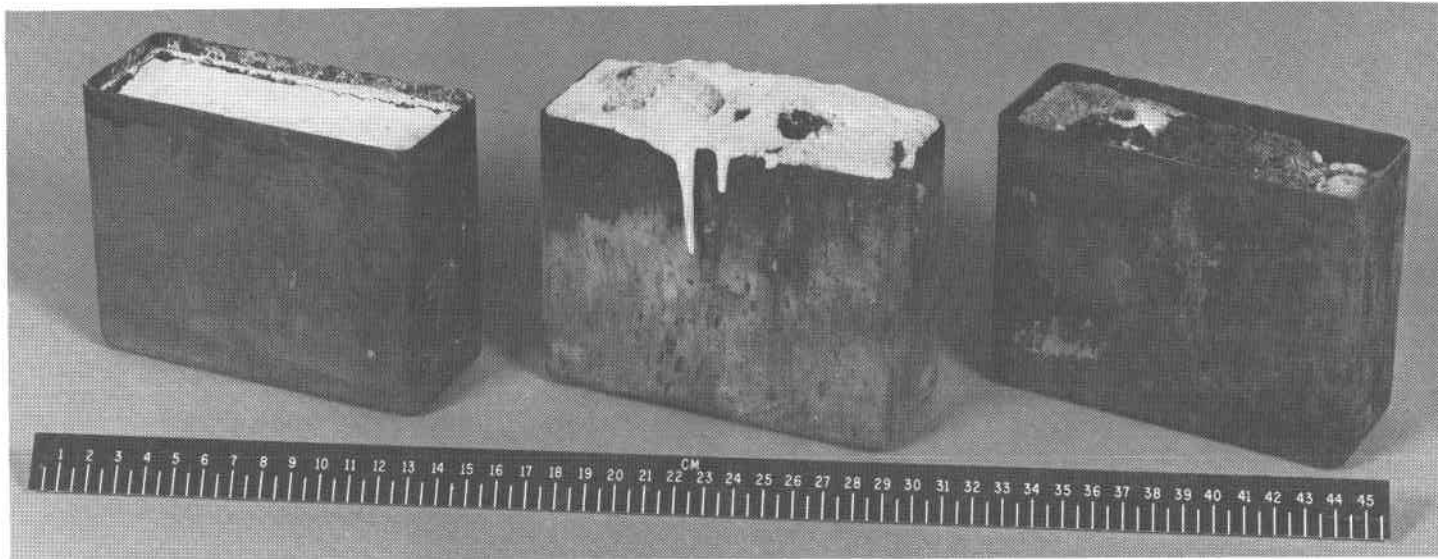

Fig. 4 — The initial laboratory energy storage runs were carried out using open salt cans, as shown in the photograph. When first filled with molten salt eutectic, and subsequently cooled, monolithic blocks of salt were obtained with a vug like central shrinkage cavity. The can on the left contains such a central cavity. Cans in which salt had been repeatedly melted and frozen in contact with m-terphenyl vapor developed a black crusted surface and showed some overflow as shown by the cans on the right. The black crust was largely water soluble, containing only a small carbonaceous content. The can on the left was not cycled.

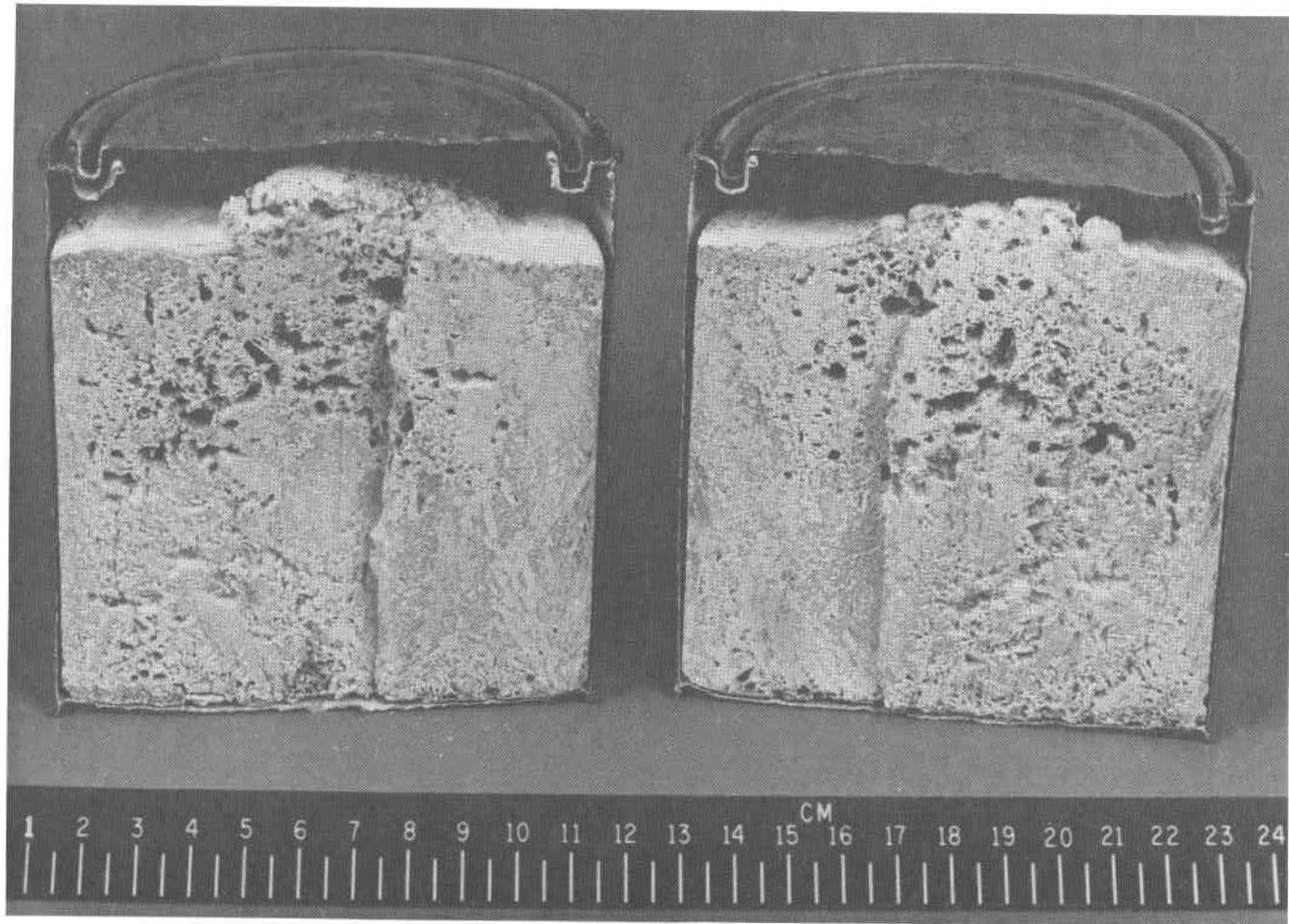

Fig. 5 — Commercially prepared salt mixes were packaged in quart paint cans with non-vapor tight lids. The figure shows salt that has been melted and refrozen 18 times in the presence of terphenyl vapor. Crusting is less evident than in the open cans, and does not threaten to overflow the can. The single cavity characteristic of freshly poured salt has been replaced with a generally porous salt structure.

By making the pressure of inert gas track the pressure of the heat transfer fluid, differential pressure forces could still be kept low. Such a design should prevent development of salt porosity.

Figure 6 shows an energy storage boiler tank configuration that uses large, separately manifold cans. The cans are made from tubes 12" OD, but contain an internal spring-loaded aluminum structure embedded in the salt, Figure 7. The embedded aluminum structure serves as a conductivity enhancement structure, permitting the 12" cans to operate thermally like 4" cans. A short test can of this type has been built, but a properly loaded test can has not yet been operated. With 12" diameter cans the manifolding problem appears manageable.

### 3. Container Materials, Technology, and Costs

Experience thus far indicates that corrosion is not a problem between thoroughly dry molten chlorides and mild steel or aluminum. Hence, conventionally thin can materials can be considered. The cans are required to contain liquid at high temperature, above the temperature of normal solders. Hence, the conventional crimped-soldered can construction is not practical. Fortunately the can industry now has the capability to produce welded steel cans using continuous seam spot welds for fabricating the steel tube forming the can cylinder and also for sealing can bottoms and tops to the cylinder. With present day equipment cans 19" long can be made by this technology. For cans designed so as to be compatible with modern can manufacturing machinery, production of millions of cans at low cost is practical. Estimates based on production of 19" long cans, 4" diameter with welded bottoms, and otherwise resembling cans used in the food industry, is  $10^6$  \$ per million cans. Such cans would be made from .007" steel. The contribution of the can cost to storage cost would then be  $2.20$  \$ kWh<sup>-1</sup>. Appendix G discusses current container technology and costs in greater detail.



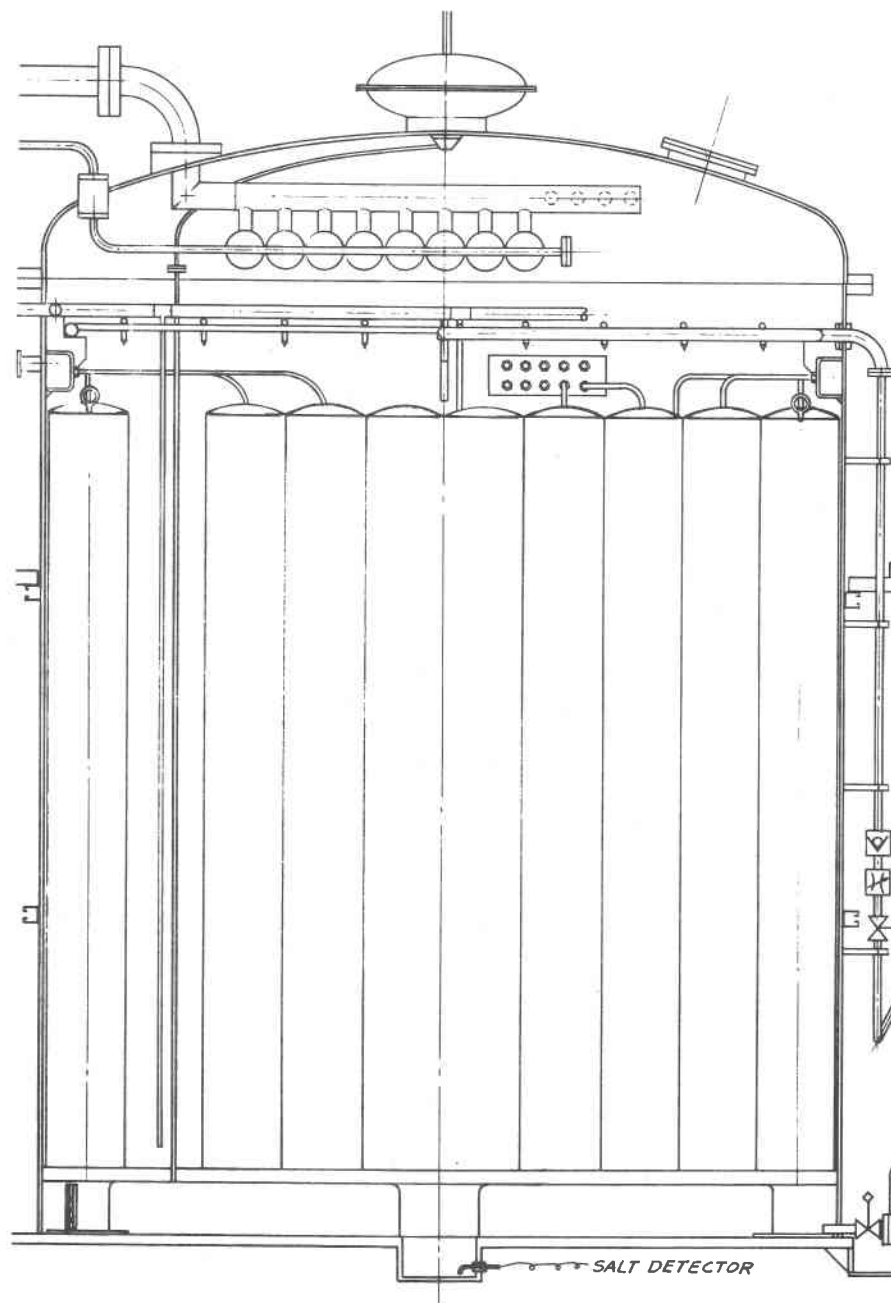

Fig. 6 — Energy storage boiler tank with separately manifolded salt cans. Because  $\text{MgCl}_2$ ,  $\text{NaCl}$ ,  $\text{KCl}$  salt eutectic freezes into a porous block in the presence of terphenyl vapor, it may be desirable to provide an inert atmosphere in contact with the salt. Such an atmosphere can be provided in a practical manner by using very large salt cans which are individually manifolded to an inert gas supply whose pressure is made to follow the terphenyl pressure within the tank. The figure shows large verticle salt cans filling the bulk of the tank, terphenyl shower heads above the salt cans, and the condensation boiler inside the tank dome. The rectangular plate with gas ports below the shower heads, and the two rectangular boxes shown in cutaway on the left and right tank wall interiors are the inert gas manifolds from which gas is distributed to each of the salt containment cans. Gas tubes (8 shown) are connected between the inert gas manifold and a connection on each salt can. The large salt containers are 12 inches in diameter and must have internal heat conduction means to deliver heat to the salt with acceptably low temperature drop, as shown in Figure 7. This design concept is not used in the NRL tank.

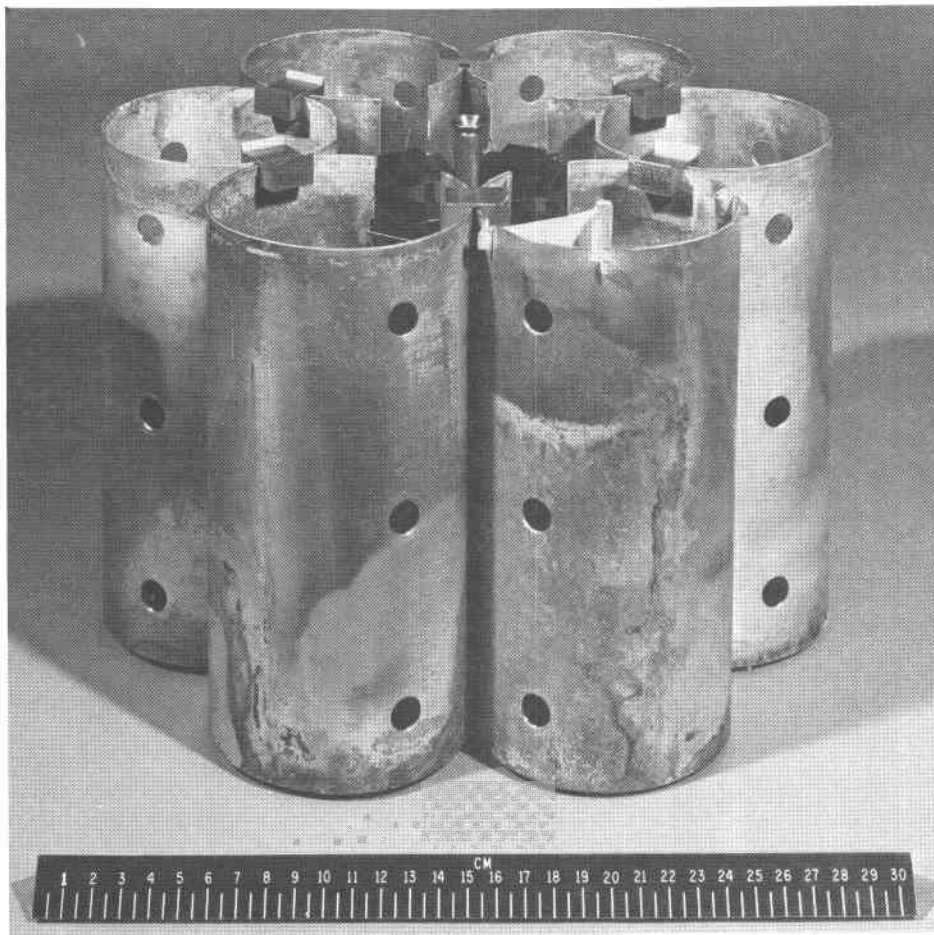

Fig. 7 — Conductivity enhancement assembly used to conduct heat from the periphery of a 12" diameter salt can to the interior, making the 12" can resemble thermally a grouping of 4" cans. The conductivity enhancement structure is made of aluminum, which is compatible with thoroughly dried salt eutectic. The structure is spring loaded to maintain thermal contact with the steel container walls.

Figure 8 shows one of the 19" cans which will be used in the 2 MWht tank. For details on the cans including actual costs and cost estimates for large production runs see Appendix G. Figure 9 shows an alternate can concept. The cans are 40" long and use continuous seam welds. 37 cans are banded together for loading as a unit. For the relatively small number of cans required for the test tank, there would have been little difference in can costs. Cans produced by semi-automated production techniques were selected as being closer to meeting the requirements of larger systems.

#### 4. Salt Procurement and Preparation

Salt mixes are being procured in conformity to the specification given in Table 4. The eutectic composition was determined from the work of Janecke<sup>(16)</sup>, as given in the ternary phase diagram shown in Figure 10. Salt prepared by Rossborough Corporation has been found to be sufficiently dry that further drying is not needed. Rossborough pours molten salt directly into openings in the can tops. The cans and contents are permitted to cool after filling, and then are sealed to prevent pick-up of atmospheric moisture during warehousing. The can lids are made with a breathing hole that is kept sealed during the preuse period. The breathing hole opens at elevated temperature, permitting the can to breathe during melt-freeze cycling.

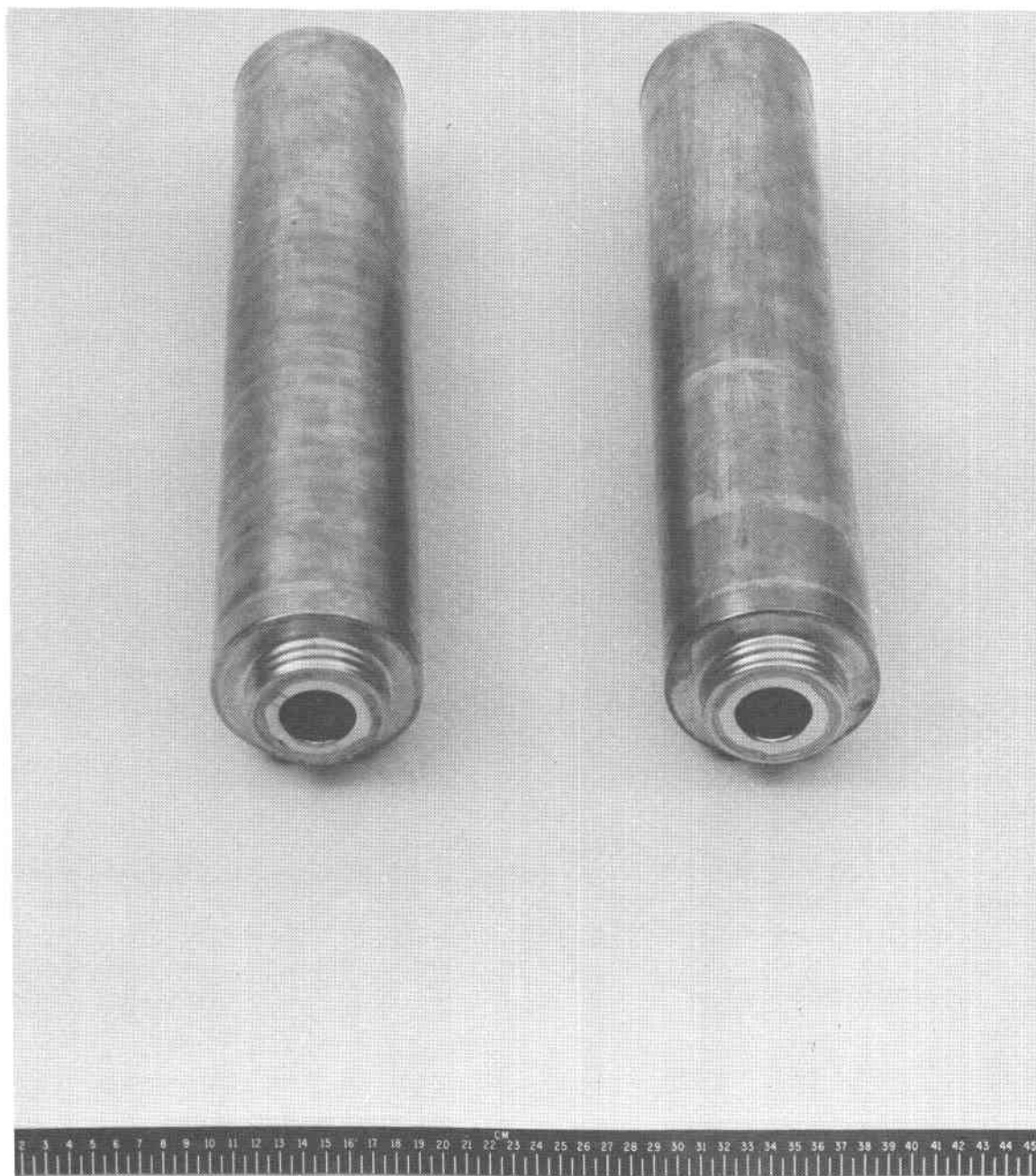

Fig. 8 — Production salt can of the type being used in the 2 MWht tank. The can has continuous welds along one side, to convert steel terneplate sheet into a cylinder, and has ring welds on top and bottom to seal can closures onto the cylinder. A screw-on lid of the type used in the food industry is provided to close off the can opening once the can has been filled with salt. This lid is sealed to the can by polymer, and provides a hermetic seal to protect the salt against ambient humidity prior to use. A breathing port in the lid opens once the can is heated toward storage temperature.

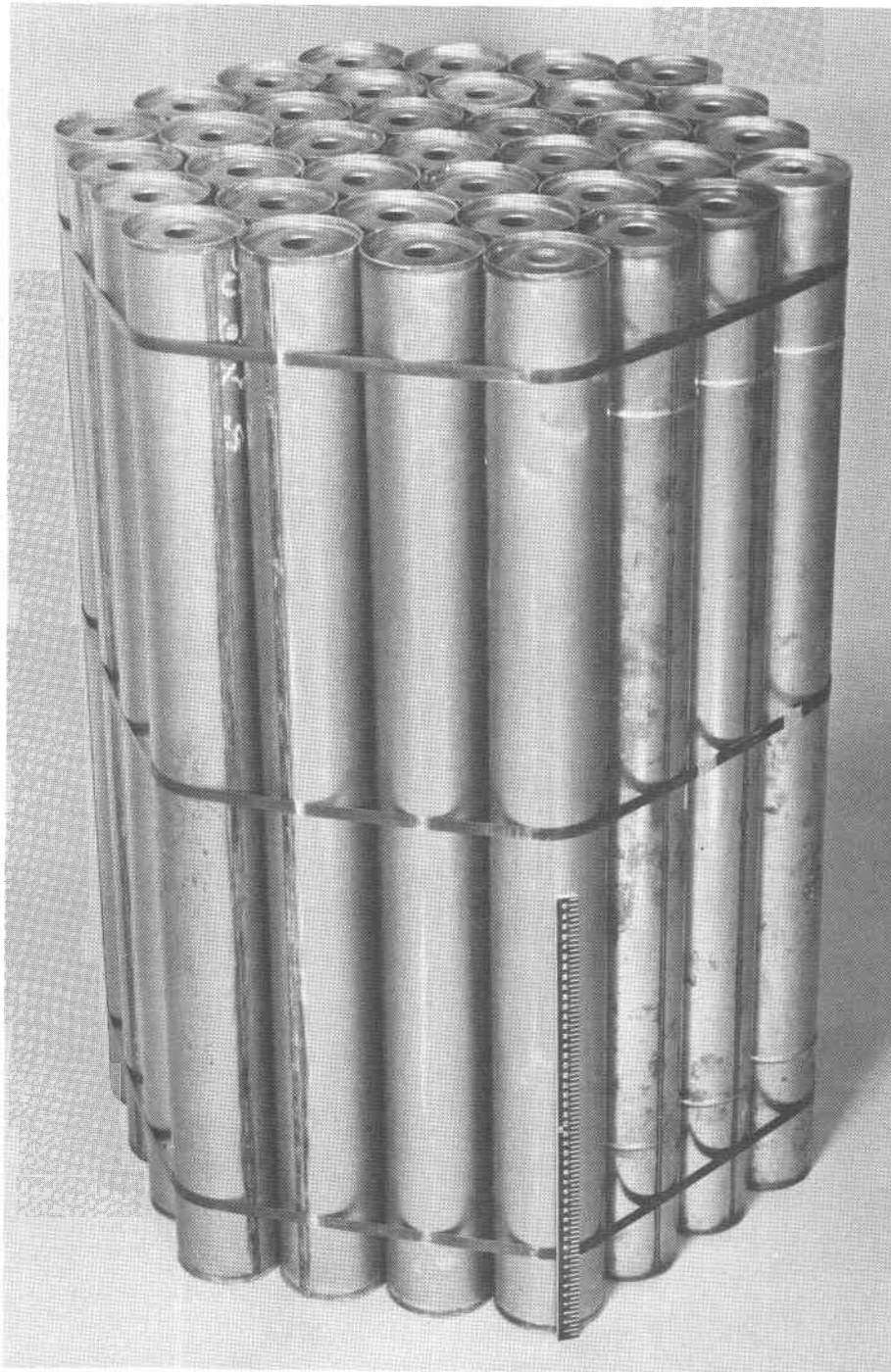

Fig. 9 — Experimental 40" long cans banded into a hexagonal assembly for loading into the storage tank. The cans are of fully welded construction and contain a  $1\frac{1}{4}$ " opening for loading with salt. Lead plugs (one shown) are sealed by RTV adhesive to close the opening so as to protect the salt from moisture pick-up during preuse storage.

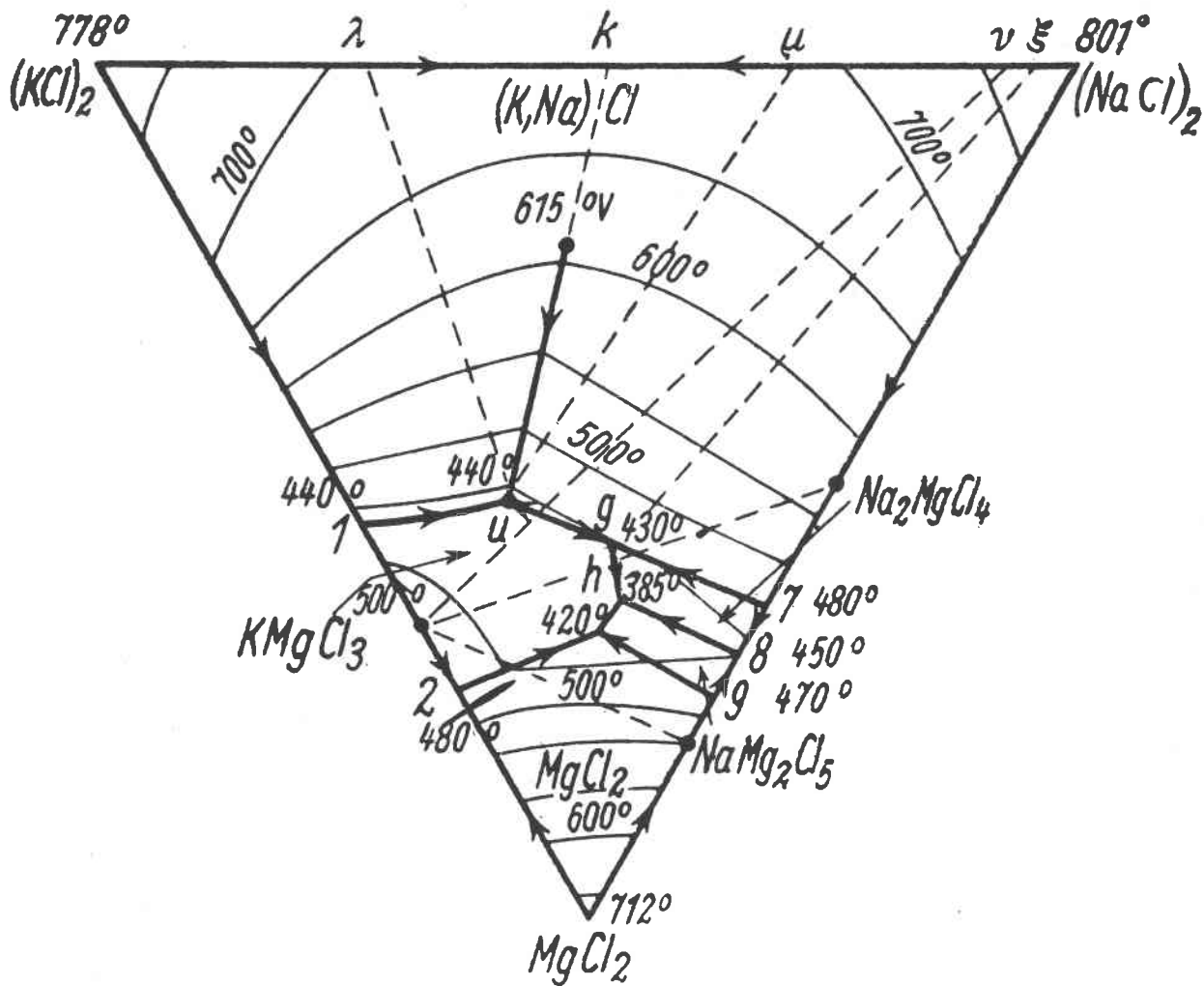

Fig. 10 — Phase diagram showing melting point contours for mixtures of  $MgCl_2$ ,  $NaCl$  and  $KCl$ , as determined by E. Janecke (1950). Compositions  $u$  and  $h$  are ternary eutectics. Compositions are mol fractions based on indicated molecular formulas. Ternary eutectic  $h$ , which melts at  $385^\circ$  is  $\sim 55\%$   $MgCl_2$ ,  $24.5\%$   $NaCl$ ,  $20.5\%$   $KCl$  by weight.

TABLE 4  
NRL Specification for Solchemite A, Grade 3

Description

Solchemite A, Grade 3, is a melt-cycled mix of sodium chloride, potassium chloride and magnesium chloride of the following nominal composition by weight:

NaCl 24.5%      KCl 20.5%      MgCl<sub>2</sub> 55.0%

In addition to the above soluble component, the mix may contain up to 4% insoluble residue (MgO).

Test Specifications

Solchemite A, Grade 3, must meet the following test requirements:

Melting point = 379-391°C (715-735°F).

Salt shall be sufficiently dried so that immersion of magnesium metal in a melt of the salt at  $T > 455^{\circ}\text{C}$  (850°F) shall result in a gas generation rate not exceeding 0.1 cc per minute per cm<sup>2</sup> of magnesium surface.

Solid shall dissolve in water producing an insoluble residue not exceeding 4% of mass of solid placed in water.

Packaging

Material shall be melt poured into airtight metal cans for exclusion of moisture. The cans will be supplied by NRL and will be ~19" high and 4" in diameter.

**V. 2 MWht Tank**

1. Test Rationale

The 2 MWht energy storage tank was conceived as a minimum size proof-of-concept test of heat-of-fusion storage in containerized salt using the evaporation-condensation energy transfer option. Although it has been possible to test several aspects of the energy storage boiler tank using laboratory scale equipment, as described in Appendix H, other aspects require a certain minimum size test unit. The most important aspect not studied in the laboratory is

the energy withdrawal process, i.e., the heat flow within the cans during freezing, the terphenyl circulation loop that continuously resupplies terphenyl to the liquid film evaporating from the cans, and the condensation boiler. Another feature that will be simultaneously tested is the practicability of large salt containers. The proof-of-concept test can be expected to show up the inevitable problems associated with scale-up.

The 2 MWht tank is based on a particular material set: m-terphenyl heat transfer fluid and  $MgCl_2$ , NaCl, KCl salt. These materials were chosen, because it was expected that an immediate start toward building a proof-of-concept storage system based on them could be made. There have been no developments subsequently that make us believe that this was not a good choice. This is not to say that the above material set is the perfect choice for larger systems, and it would only be reasonable to consider other material sets before moving beyond this first proof-of-concept demonstration.

## 2. Tank Construction

The 2 MWht tank is shown in sketch form in Figure 11. Specifications are given in Table 5. The basic tank is a welded mild steel tank made with 2" steel plate bottom and 1/2" steel plate walls. The tank rests on an insulation platform of Pittsburgh-Corning Foamglas 24" thick. (Foamglas H/T has a crush strength of 100 lbs in<sup>-2</sup>.) The Foamglas, in turn, rests on a concrete base. The tank is 10.5' in diameter and 12' high, and is fitted with a ring flange to receive a similarly flanged dome cover. The tank is oversized structurally so as to permit evacuation if such seems desirable. The tank bottom is fitted with a sump well, from which terphenyl is piped to supply the terphenyl circulation loop during energy withdrawal. The side walls of the tank are pierced to receive three high temperature electric feedthrough fittings, namely Varian vacuum feed-through type 9545009. The inside terminations of the feedthroughs are



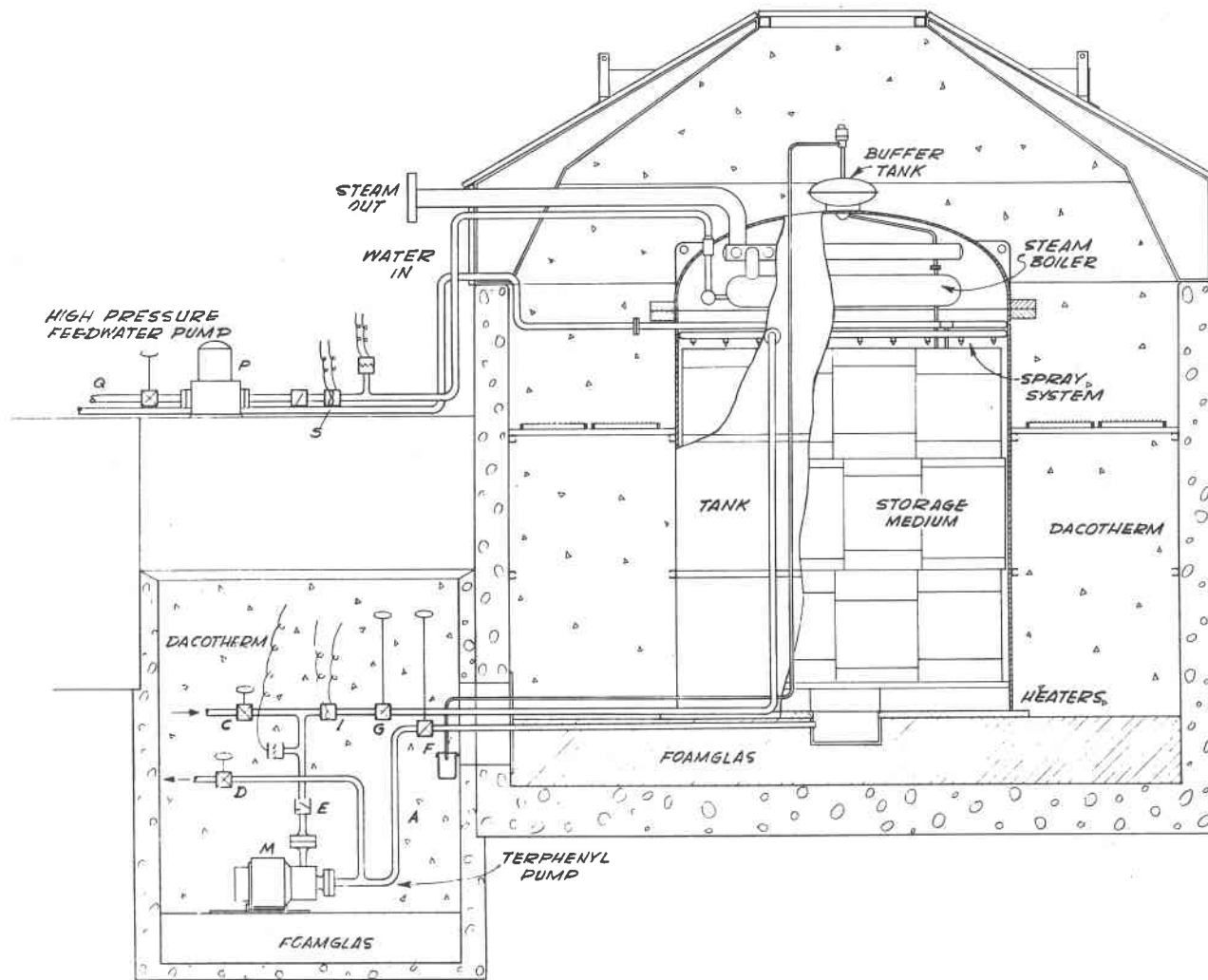

Fig. 11 — Drawing of 2 MWh energy storage boiler tank being constructed at NRL. Drawing shows cut-away view of interior of tank, which is largely filled with basketed cans of salt. Electrical heaters cast in aluminum and located in the tank floor are used to heat the tank. The steam boiler-superheater is contained within the dome of the tank. Below the boiler are the m-terphenyl spray heads which keep the cans of salt moist with terphenyl liquid during energy withdrawal. The tank is mounted on a Foamglas base. The tank contains a sump from which liquid terphenyl flows with a gravity head down to a hot liquid circulation pump, which supplies the terphenyl spray system. A buffer tank and terphenyl bleed line is used to provide a means of breaking up vapor fractionation layers within the tank. Such layers are caused by impurities in the heat transfer fluid. Also shown in the figure is the high pressure feedwater pump which supplies water to the boiler.

TABLE 5  
Specifications: 2 MWh Tank

ITEM	VALUE
<b>Storage Characteristics</b>	
Storage Capacity <sup>(a)</sup>	1.82 MWht = 6.55 GJ = $6.2 \times 10^6$ BTU
Max Energy Input Rate	150 kW
Min Fill Time	12.1 h
Design Output Rate	150 kW
Design Energy Withdrawal Time	12.1 h
Heat Loss to Environment	3000 W estimated
Energy Half-Life	25 days
<b>Tank Configuration</b>	
Inside Diameter	3.18 m (10.4 ft)
Inside Height to Flange	3.66 m (12.0 ft)
Inside Height to Dome	~4.6 m (~15 ft)
<b>Containerized Salt</b>	
Salt Mass	27 T (metric)
No Cans	4000
Can Diameter	10.2 cm = 4"
Can Height	.46 m = 18.2"
Can Volume	3.75 liter
Salt Mass Per Can	6.82 kg (liquid density = $18.2 \text{ g cm}^{-3}$ ) <sup>(b)</sup>
<b>Heat Flux Into Salt</b>	
Can Sidewall Area	690 m <sup>2</sup>
Heat Flow Density @ 150 kW at Can Wall	254 W m <sup>-2</sup>
Temperature Drop Through 4 cm of Salt <sup>(c)</sup>	20°C
<b>Terphenyl Circulation</b>	
Mass Flow Rate @ 150 kW	.54 kg s <sup>-1</sup>
Condensation Rate @ 150 kW	.68 liter s <sup>-1</sup> of liquid (10.7 gpm)
Vapor Pressure @ 365°C <sup>(d)</sup>	100 kPa (1.0 atm. 14.7 psia)
Perfect Gas Density	4.40 g liter <sup>-1</sup>
Gas Volumetric Flow	.123 m <sup>3</sup> s <sup>-1</sup>
Flow Velocity for 10% Open Area	.15 m s <sup>-1</sup> (.05 ft s <sup>-1</sup> )
<b>Steam System</b>	
Steam Pressure	5.4 MPa (800 psi)
Steam Temperature	371°C (700°F)
Steam Output (@ 150 kW Withdrawal)	.05 kg s <sup>-1</sup> (393 lb hr <sup>-1</sup> )
Water Feed Temperature	21°C (71°F)
Water Flow Rate	.05 liter s <sup>-1</sup> (.8 gpm)

(a) Salt heat-of-fusion only.

(b) Based on observed pour level in cans which are subsequently weighed.

(c) Based on  $k = .87 \text{ W m}^{-1} \text{ K}^{-1}$ . Ref. radius = 3 cm.

(d) *Handbook of Chemistry and Physics*, 48th edition, p. C-560 (1967).

connected to power busses which deliver 3-phase power to cast-in-aluminum 5 kW electrical heater elements having a total capacity of 180 kW. The heater element configuration is shown in Figure 12. The interior wires pass below the surface of the insulating terphenyl fluid, which helps to keep the conductors at acceptable temperature.

The electrical heater elements rest directly on the tank bottom. They in turn support a steel grate on which rest baskets of salt cans. The salt cans are 4" in diameter and 19" long. Most of the cans are packed into hexagonal baskets holding two layers, each containing 36 cans. Some of the cans are packed in truncated baskets holding 2 layers, each containing 27 cans. Three layers of baskets are used. The total salt loading is about 30 tons, packaged in 4000 cans.

The cylindrical wall of the tank is pierced just below the flange to receive the terphenyl recirculation pipe. This pipe supplies pumped terphenyl liquid to an array of shower heads within the tank. The shower heads spray liquid on the salt cans during energy removal, replacing liquid evaporated from the terphenyl film coating the cans. The terphenyl circulation system is described subsequently.

The top of the tank is closed with a domed carbon steel lid, flanged to mate with the tank. A high temperature pressure seal is made by means of an Inconel metal O-ring coated with silver. The domed lid contains within it a steam boiler and superheater. It is pierced to receive cold feedwater and to exit hot superheated steam.

The sides of the tank are insulated with 40 inches of Dacotherm sodium silicate insulation. The assembly is protected from weather by concrete walls and a removable weather protective roof, Figure 11.

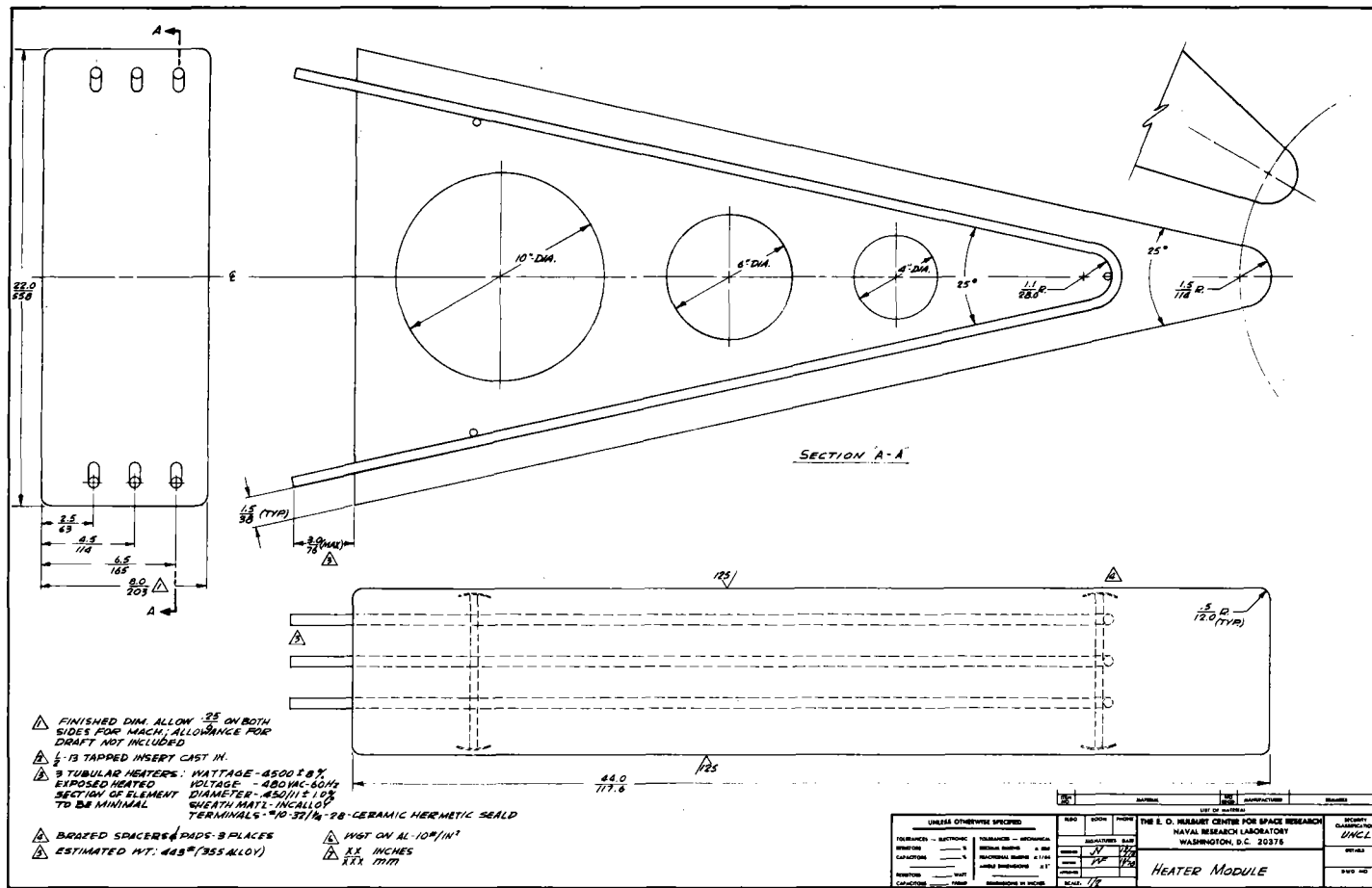

Fig. 12 — Drawing of one segment of the heater element used to energize the 2 MWh energy storage boiler tank. The element is a nichrome heater cast in an aluminum housing. Total input heater power is 150 kW.

### 3. Tank Specifications

The proof-of-concept tank is designed to store 1.8 MWh ( $6.2 \times 10^6$  BTU) of thermal energy at 385°C. It is designed to receive energy at any input rate up to 150 kW and to deliver energy at any output energy rate up to 150 kWt ( $6.6 \text{ lbs min}^{-1}$  of steam at 700°F). Energy output will be in the form of superheated steam at 800 psi. An energy delivery capability of greater than 150 kWt is expected. One of the engineering tests planned for the tank is a determination of maximum steam flow rate.

Overall operating characteristics and design parameters are given in Table 5.

### 4. Analysis of Heat Flow in Salt

Significant temperature drops occur in the solidified salt layer within the cans at high energy withdrawal rates, Table 5. If there were no salt porosity problem, the final temperature drop which should occur when the last salt freezes would be 20°C at 150 kWt withdrawal rate. These calculations are based on neglecting end effects and on assuming that the salt contracts 25% on cooling. The volume of void created during solidification of salt after pouring liquid into an open can was measured by filling the void with toluene. Using weight measurements to determine the volume of toluene, the accessible void fraction was found to be 18.5% of the liquid fill volume. A thermal conductivity of  $0.87 \text{ W m}^{-1} \text{ K}^{-1}$  is used. If porosity proves a problem in the long cans, the calculation may be optimistic as regards temperature drop. Engineering tests should show the seriousness of the problem.

### 5. Water—Steam System

The operation of the condensation boiler and superheater has been analyzed in accordance with the treatment given in Appendix D. Figures 13 and 14 show the boiler superheater

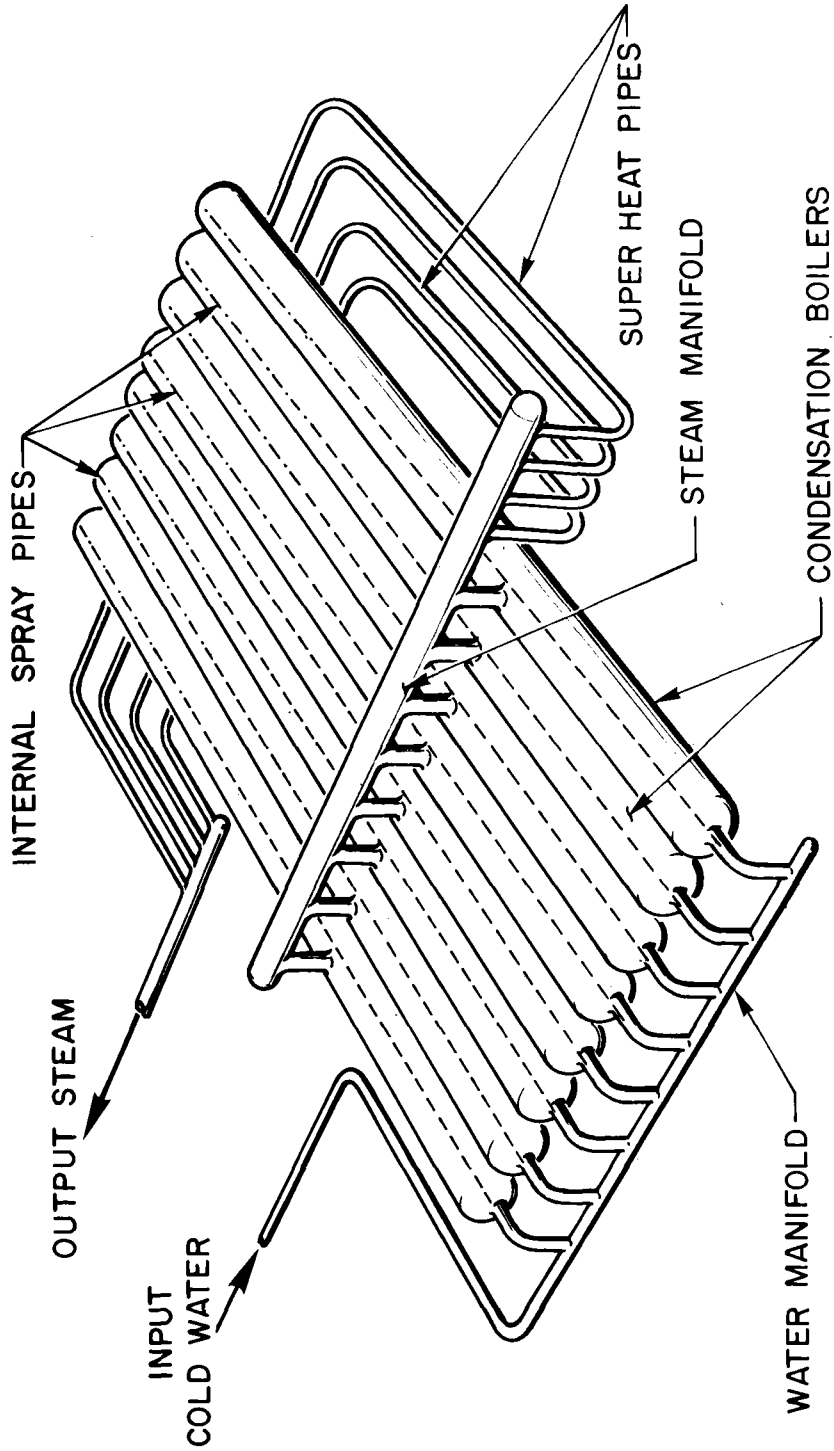

Fig. 13 — Early design of condensation boiler-superheater. Boiler consists of 8 parallel boiler tubes connected by heaters to the feedwater line and to output superheater lines. All lines are heated by condensation of terphenyl vapor.

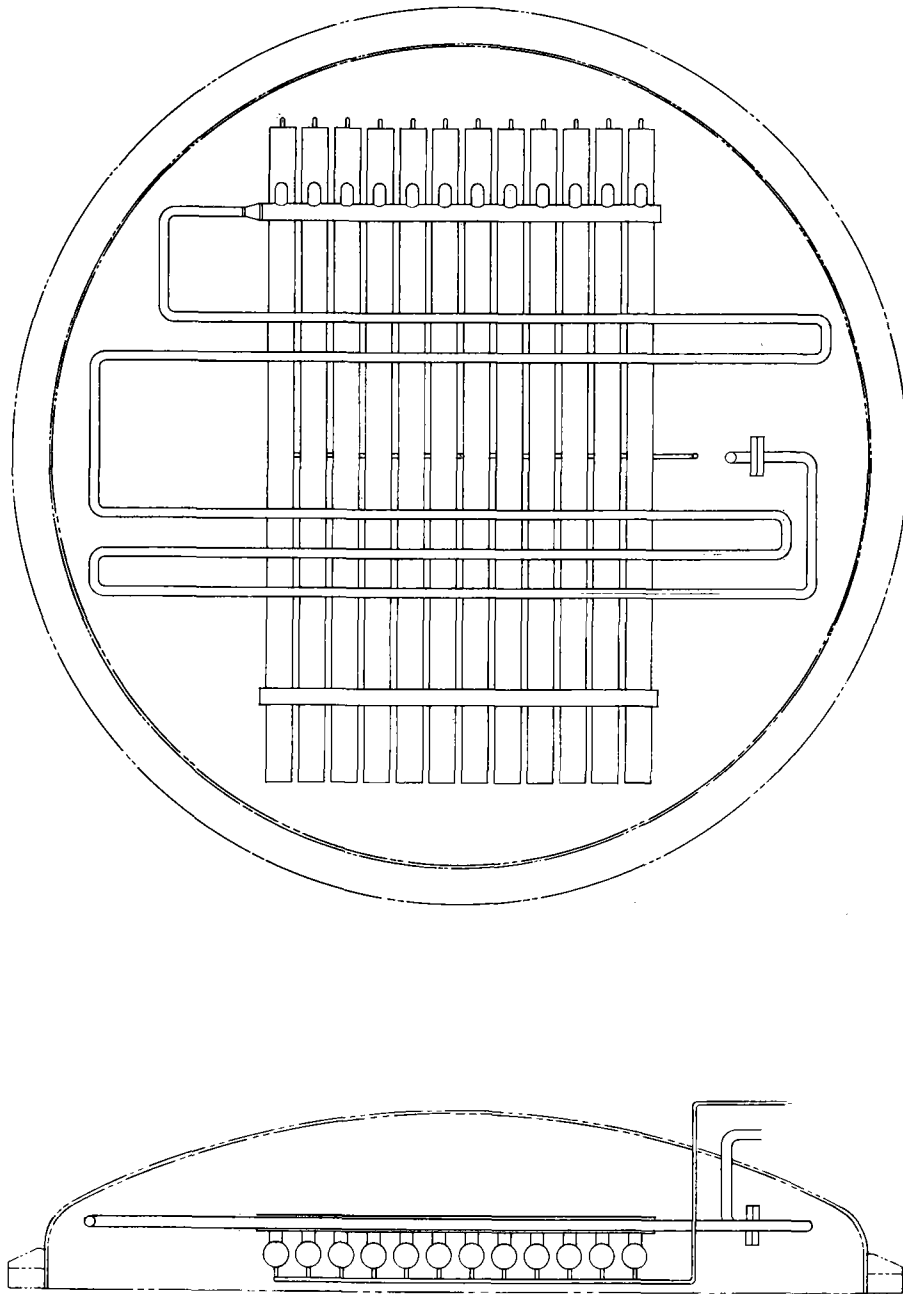

Fig. 14 — Boiler-superheater as redesigned for 2 MWht tank. Twelve boiler tubes are used in parallel. The parallel superheater lines shown in Fig. 13 have been replaced by a single superheater line of similar total length. Series flow design provides better heat transfer to the moving steam.

design. The condensation boiler system operates in a different regime than that encountered with conventional boilers in that the boiler and superheater tubes are always hot and are subject only to relatively small temperature excursions. Burn-through cannot occur. The method of feedwater heating is also novel. The concept is shown in Figure 15. Feedwater heating is carried out inside each boiler section by steam condensation. This steam condensation is effective in delivering heat to the feedwater tubes, and metal to liquid water heat transfer is very effective in delivering the condensation heat to the feedwater stream. The result is a very rapid rise in feedwater temperature as the water flows through the injection tube within the boiler, as shown in Figure 16. The feedwater, however, can never flash into steam in the lines. Near the end of the tube, the water is sprayed upward onto the hot upper surface of the boiler. In this manner it is expected that quenching of agitation in the boiling pool of water in the bottom of the boiler will be prevented. Agitation due to boiling is important in maintaining good heat transfer between the walls of the boiler and the boiling pool of hot water.

Figure 17 shows the calculated temperature rise in the superheater. Steam flow rates are low compared to typical boilers. To maintain reasonable mass flow densities, a long single steam outflow superheater tube is the preferred configuration to give good wall to steam heat transfer. Figure 18 shows calculated pressure drops vs. energy withdrawal rates. Despite the length of the superheater tube employed, the pressure drop is small even at a 1000 kWt energy withdrawal rate.

Figure 19 shows schematically the layout of the water-steam system. The feedwater supply is designed to permit operator control of flow rates down to very small flow rates. Rather than to use variable displacement pumps, feedwater by-pass is used to control the feedwater supply to the tank. The feedwater supply system is an adaptation of the water system used to feed the large solar heated boilers at the Sandia Solar Thermal Test Facility<sup>(17)</sup>.



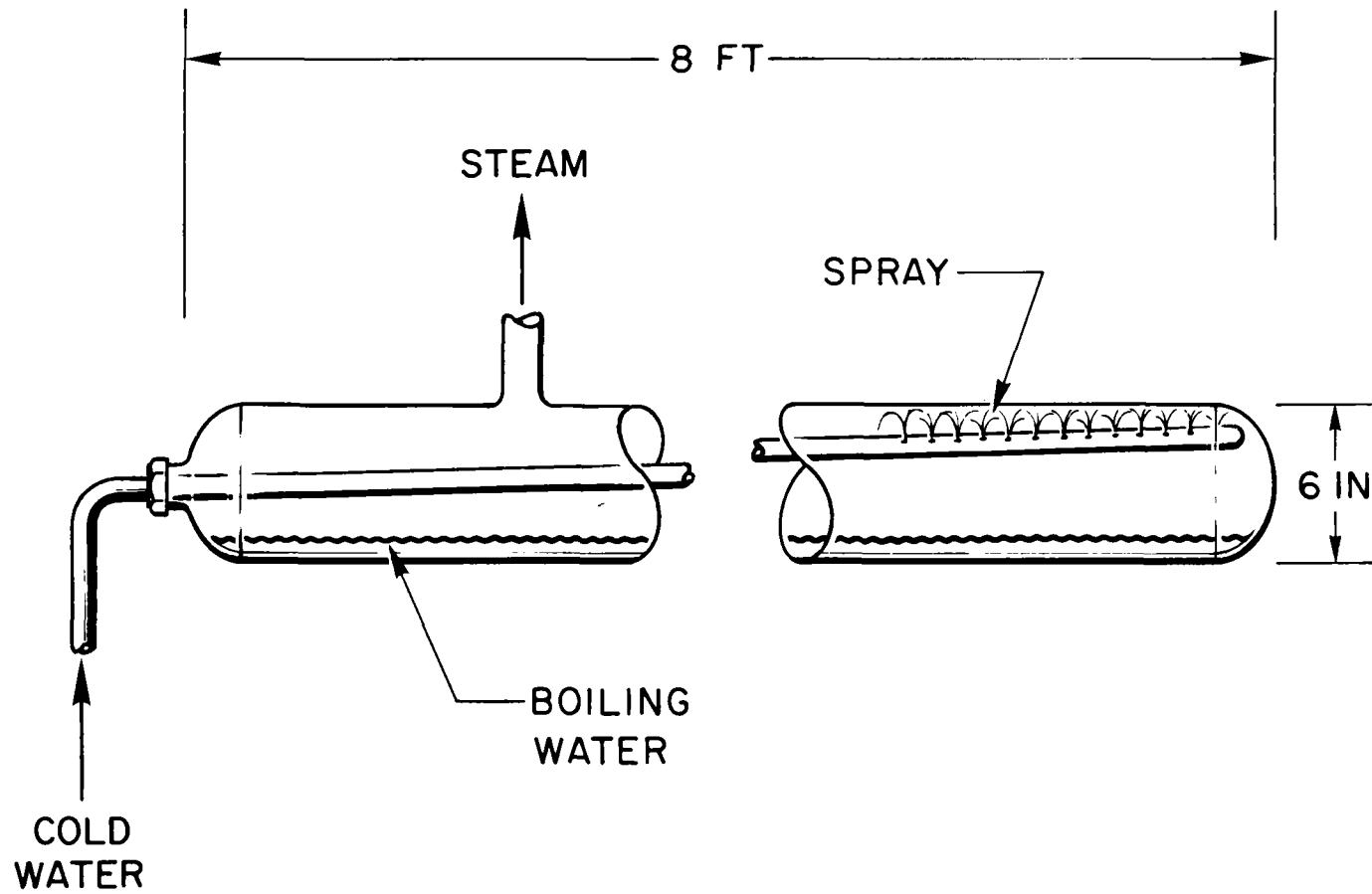

Fig. 15 — Drawing illustrates feedwater preheat concept. Cold water from feedwater line is heated by steam condensation on water preheat lines contained internal to the boilers. Last portion of preheat line contains water inlet holes through which water is sprayed away from boiling water in bottom of boiler. Design prevents feedwater from flashing into steam prior to passage through these inlet holes. The preheat concept should prevent quenching of boiler agitation due to cold water inflow.

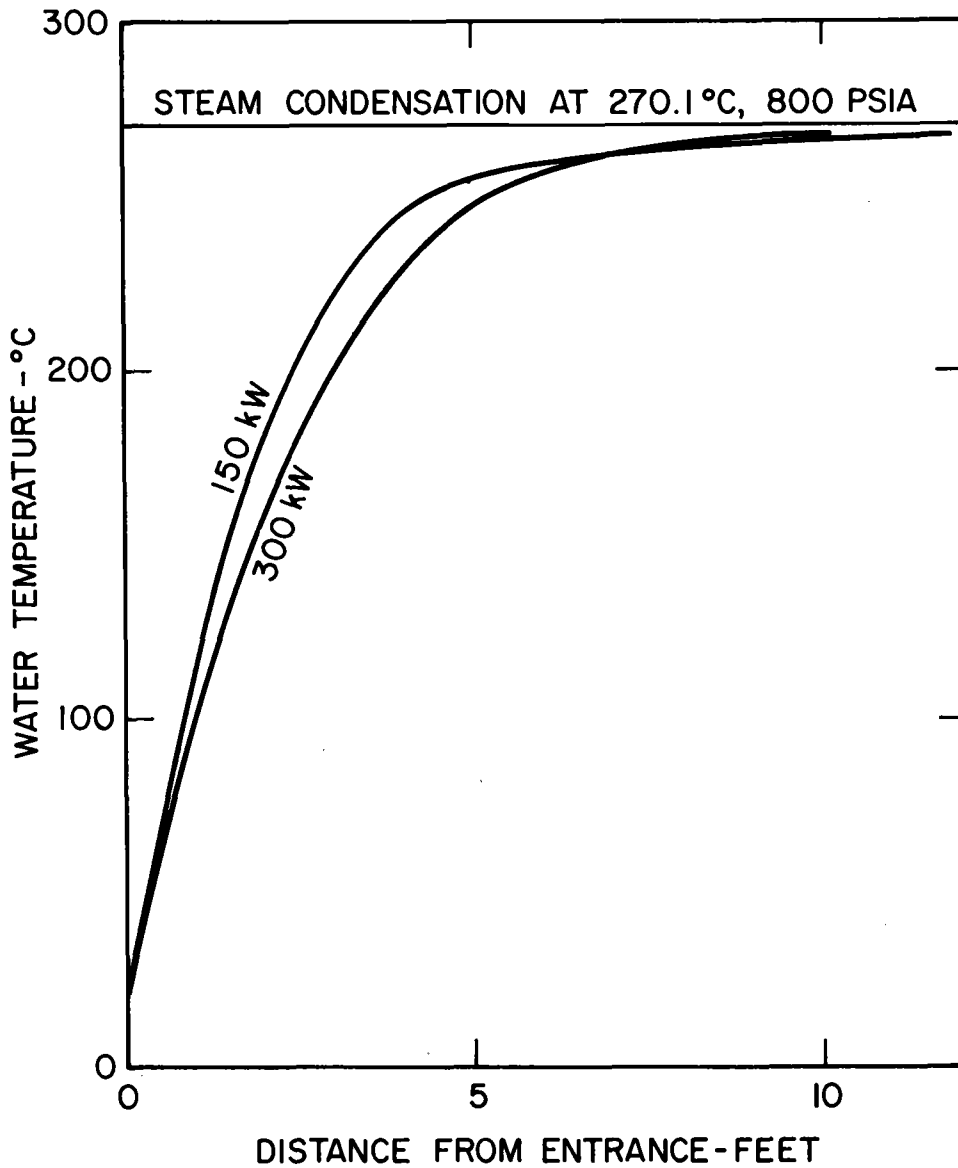

Fig. 16 — Calculated performance of feedwater preheat system. Feedwater is assumed to enter the preheat line inside the boiler at 20°C temperature. Condensation of steam on preheat line rapidly raises temperature toward the steam condensation temperature. The curves show temperature rise vs. flow distance, as expected during operation of the boiler shown in Figure 13 (8 boiler tubes) at total energy withdrawal rates of 150 kW and 300 kW. Since the feedwater flows more than five feet before encountering entry holes, the entering water is calculated to be above ~240°C.

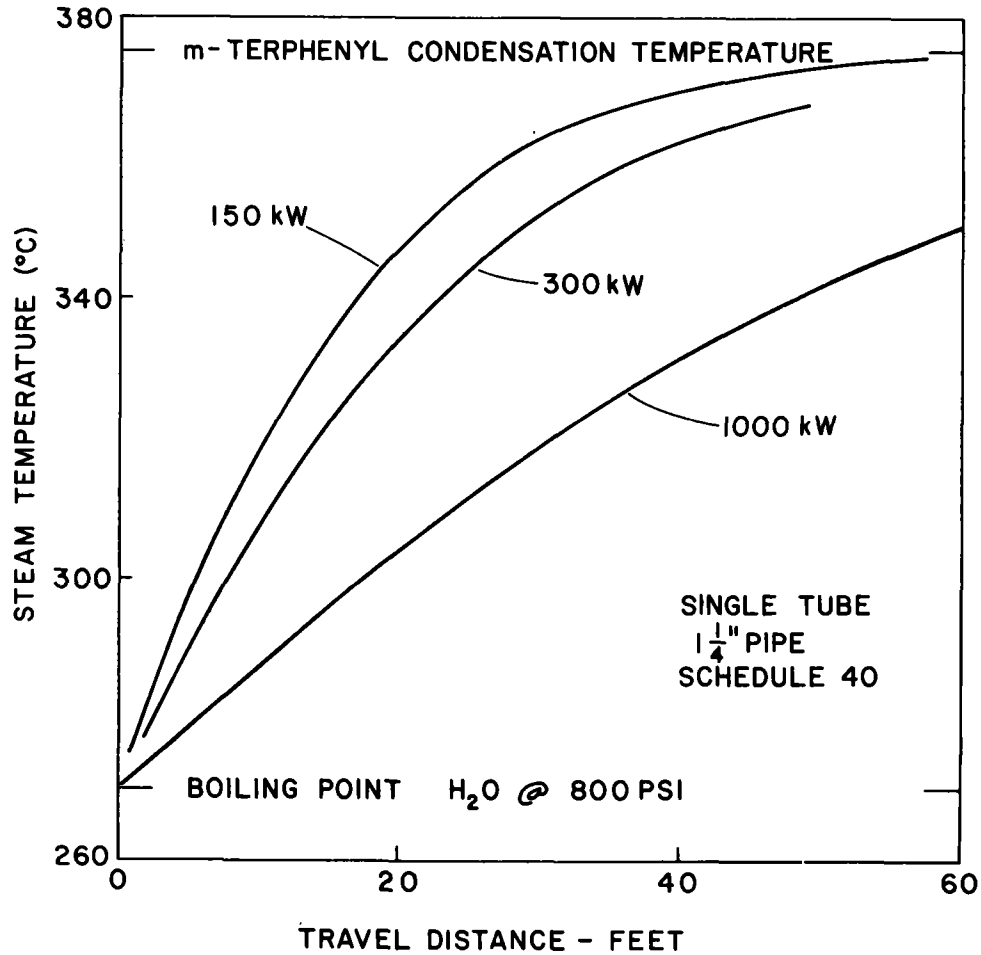

Fig. 17 — Calculated performance of superheater shown in Figure 14. The superheater is heated by condensation of m-terphenyl vapor. Steam leaving the boiler at boiler temperature rapidly rises in temperature as it travels through the superheater tube. In the section of superheater closest to the boiler, heat flow rates at 1000 kWt energy withdrawal rate are largely limited by conduction through the film of terphenyl liquid which coats the line. Near the superheater exit point, heat flow is largely limited by heat transfer between steel tube and moving steam at 150 kWt energy withdrawal rate. At 1000 kWt withdrawal rate, conduction through the liquid terphenyl film affects heat flow everywhere. 1000 kWt corresponds to a steam delivery rate of 2600 lb hr<sup>-1</sup>.

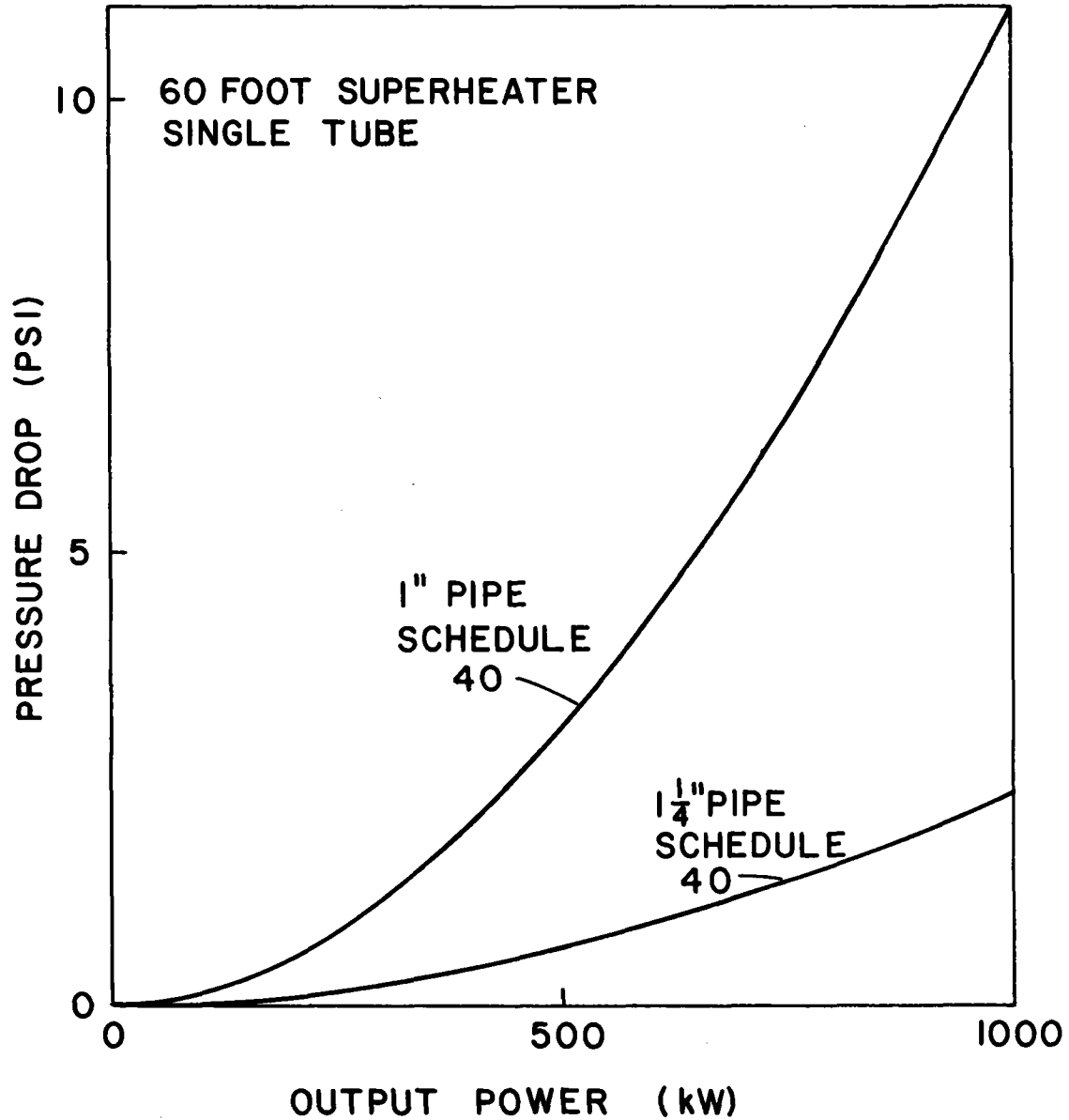
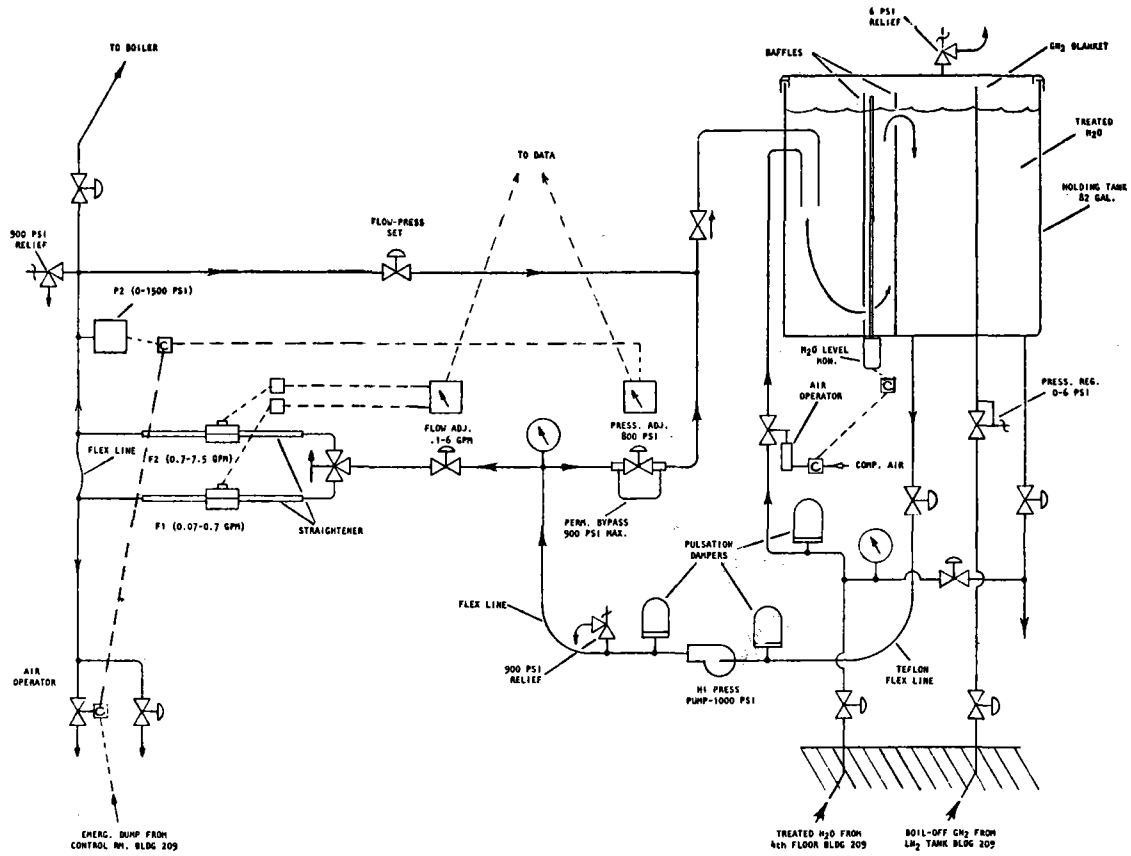
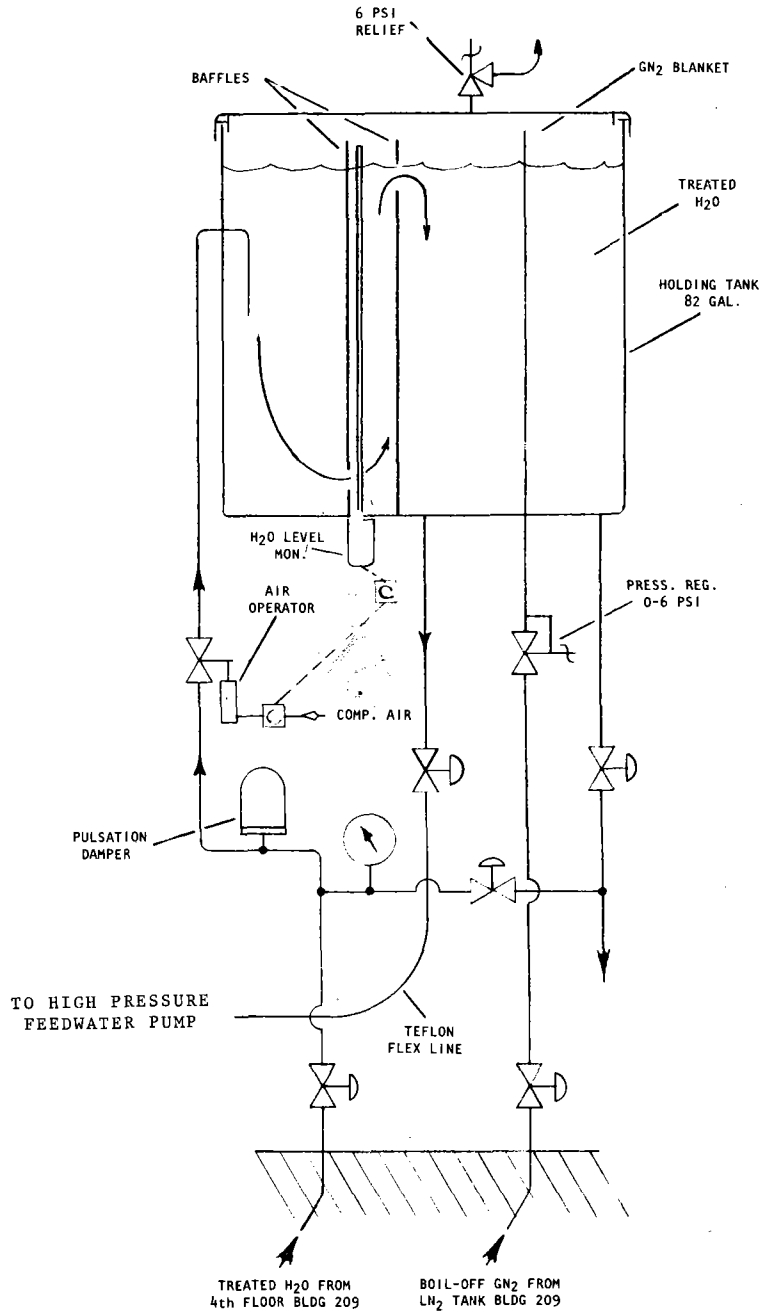

Fig 18 - Calculated steam system pressure drop vs. energy withdrawal rate. During operation water flow rate will be adjusted to maintain 800 psia output steam pressure. At 1000 kWt energy withdrawal rate, the feedwater pump will provide feedwater at 802 psia.



(A)

Fig. 19 — Water-steam system. Fig. 19A shows the complete loop. Fig. 19B shows an enlarged view of the low pressure water supply portion of Fig. 19A. Fig. 19C shows an enlarged view of the high pressure portion of Fig. 19A. Referring to Fig. 19B, at the bottom left of the figure, treated water is received at the site from an underground water line originating at a nearby NRL building. This water flows into a nitrogen-blanketed on-site holding tank in which the water level is controlled in response to a level control. A pulsation damper is included in the input line to reduce pressure surges which could otherwise damage the underground feed line when flow is cut off. Stored water is fed to the high pressure feedwater pump under gravity head by means of a teflon flex line, which exits Fig. 19B near the left bottom of the figure. Referring to Fig. 19C, low pressure water enters the figure at the bottom right, going directly to the high pressure feedwater pump. The main flow proceeds to a T, at which a pressure gauge is shown. It turns left at the T and passes through a selectable flow meter to the feedwater header at the left edge of the figure. It then proceeds up the figure to the boiler. The high pressure feedwater system also contains two bypass loops in parallel with the boiler. The first of these bypasses, which is the only one used during actual boiler operation, is an adjustable by-pass by which high pressure water flow is dropped to low pressure and returned to the on-site holding tank shown in Fig. 19B. When only a small amount of steam is being withdrawn from the energy storage tank, most of the high pressure water flow passes through the adjustable by-pass. This permits the feedwater pump to operate at its normal pumping speed. The second by-pass is the horizontal line at the top of Fig. 19C. It is used by the operator to set up desired water flow conditions prior to passing water into the boiler. When steam generation is desired, the valve (top left) to the boiler is opened and the upper by-pass is closed off.



(B)

Fig. 19 (Continued)

CHUBB, NEMECEK, AND SIMMONS

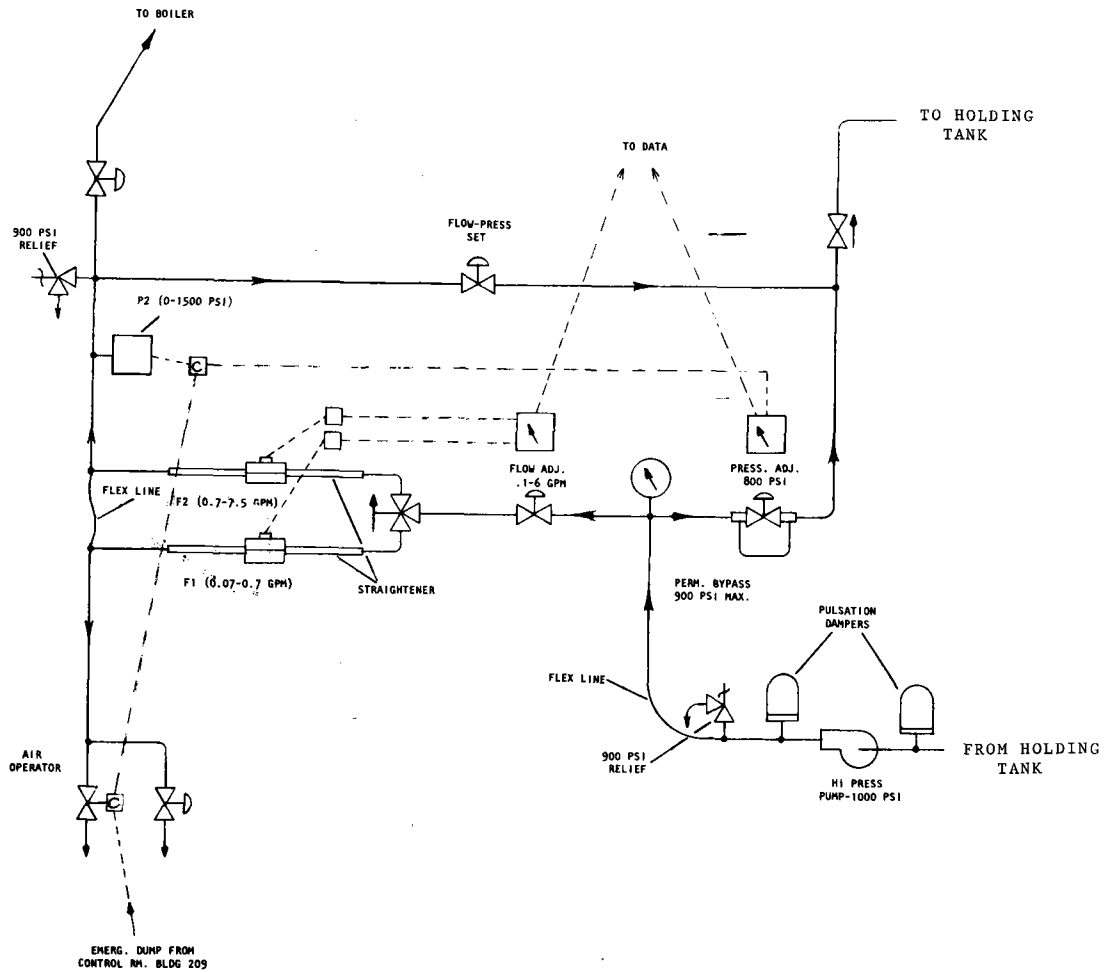

(C)

Fig. 19 (Continued)

## 6. Terphenyl Loop and Bleed

Figure 20 shows the configuration of the terphenyl circulation system and vapor bleed. The key element in the liquid terphenyl circulation loop is a small hot chemical pump located in a pit below the level of the bottom of the energy storage tank. The pump receives liquid terphenyl from a pipe that enters the sump well in the bottom of the tank. This pipe delivers terphenyl to a centrifugal pump with a liquid head of about 6 feet. The pump raises the pressure of the fluid and delivers hot terphenyl to shower heads above the salt cans, providing liquid terphenyl circulation as previously described. Valves are provided for draining off liquid terphenyl, or adding new terphenyl as desired. The terphenyl pump itself is preheated by a hot glycol solution so as to melt any solids in the pump during restart, and to prevent freezing during nonoperating periods. The glycol solution is heated by an electric water heater during startup. The same glycol solution is passed through a radiator to provide cooling of the terphenyl pump during normal pump operation.

The laboratory test program, as explained in Appendix G, showed that it was desirable to use a buffer tank above the storage tank lid to collect high vapor fractions coming off the hot impure terphenyl fluid and to permit periodic bleeding off of these impurity fractions to a collection reservoir. The buffer tank is designed to return to the main tank any liquids that have condensed at buffer tank temperature. As shown in Figure 20, the bleed line leaving the buffer tank is heat traced to prevent solids blocking, and enters the terphenyl pump pit in which the bleed valve and collection reservoir are located.



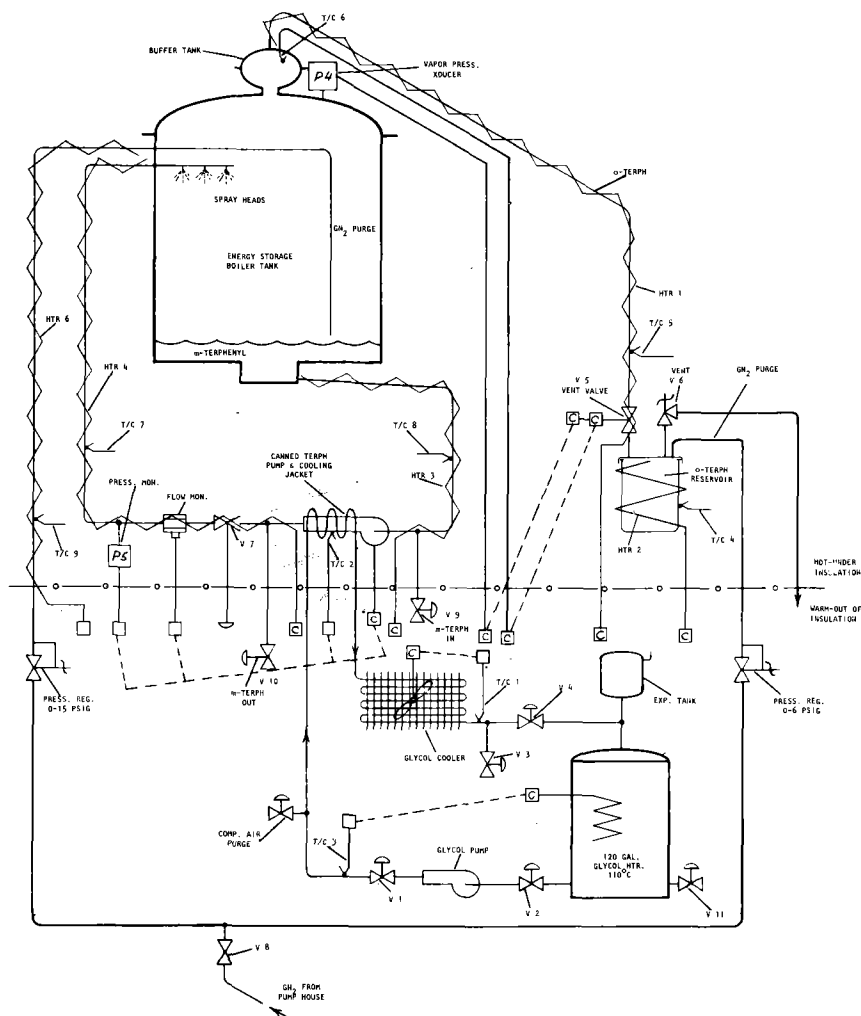

(A)

Fig. 20 — Heat transfer fluid system. Fig. 20A shows the overall heat transfer fluid system, which includes the main m-terphenyl loop and a secondary ethylene glycol loop. Much of the complication indicated on the figure is caused by the high freezing point of m-terphenyl. Zigzag tracings overlaying lines and tanks means that electrical heat tracing is provided on the indicated lines and tanks to keep temperatures above the melting point of m-terphenyl. The secondary ethylene glycol heat transfer system similarly is used during start-up to ensure that the main terphenyl circulation pump is filled with liquid prior to turn-on. Fig. 20B, 20C and 20D show selected portions of Fig. 20A in enlarged form. Fig. 20B shows the secondary ethylene glycol loop, which feeds hot ethylene glycol through the cooling coils in the terphenyl circulation pump prior to start. The loop also serves to cool the pump during operation. The terphenyl circulation pump is shown in the upper left hand corner of the figure. Ethylene glycol-water solution is stored in the "hot water heater" in the lower right hand corner of the figure. During start-up hot glycol solution is withdrawn from the bottom of the "hot water heater," is pumped through the cooling coils within the terphenyl circulation pump, is passed through a "car radiator" and returned to the "hot water tank." No air circulates through the "car radiator" during start-up. Flow is continued until temperature indicators on the terphenyl circulation pump indicate that all m-terphenyl in the pump is melted. Once the terphenyl pump is started, the glycol loop serves to cool the terphenyl pump. Air flow through the radiator is initiated to prevent glycol overheating. The loop includes a small expansion tank to accommodate volume changes accompanying heating of the glycol solution.

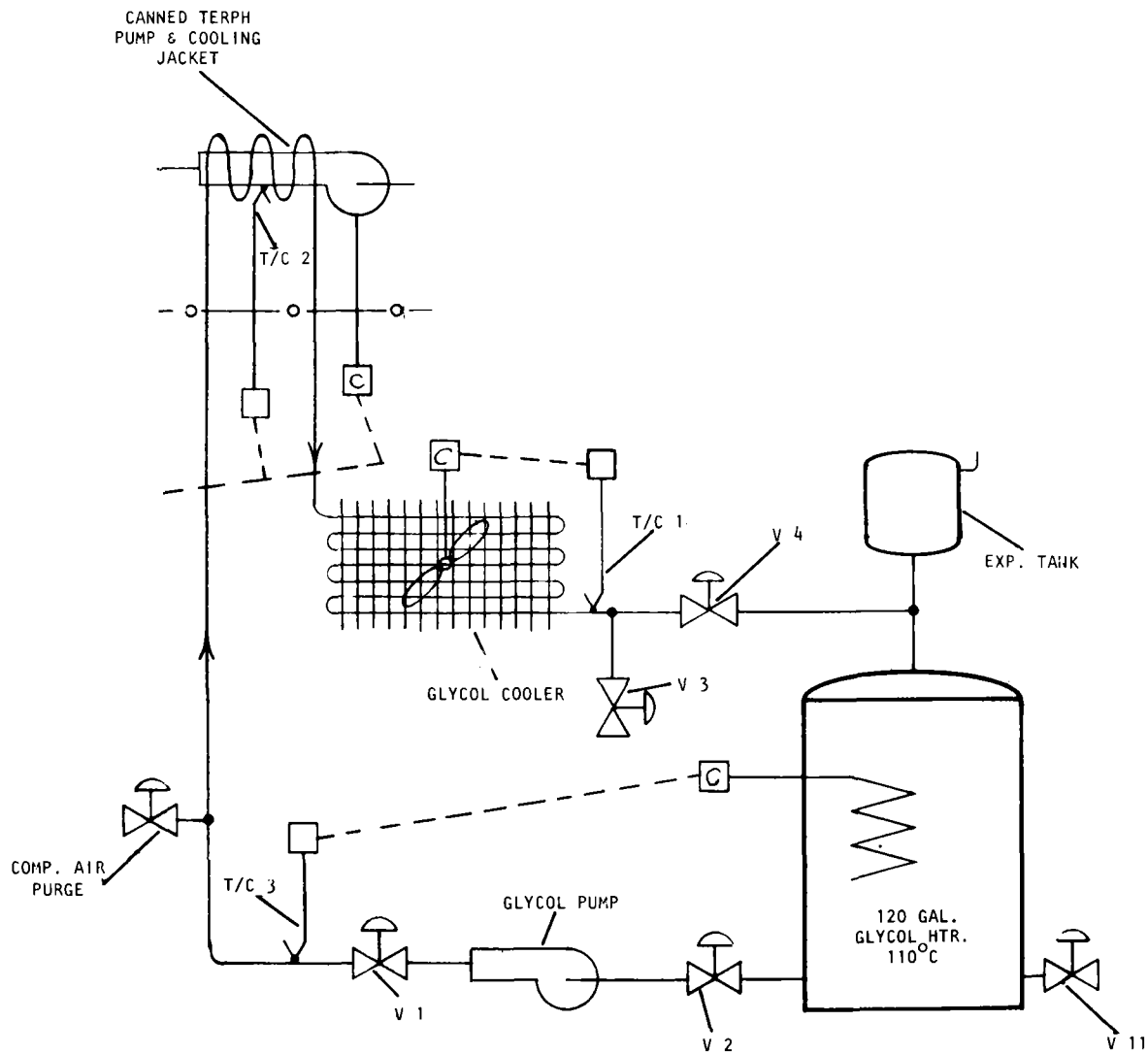

(B)

Fig. 20 (Continued)

CHUBB, NEMECEK, AND SIMMONS

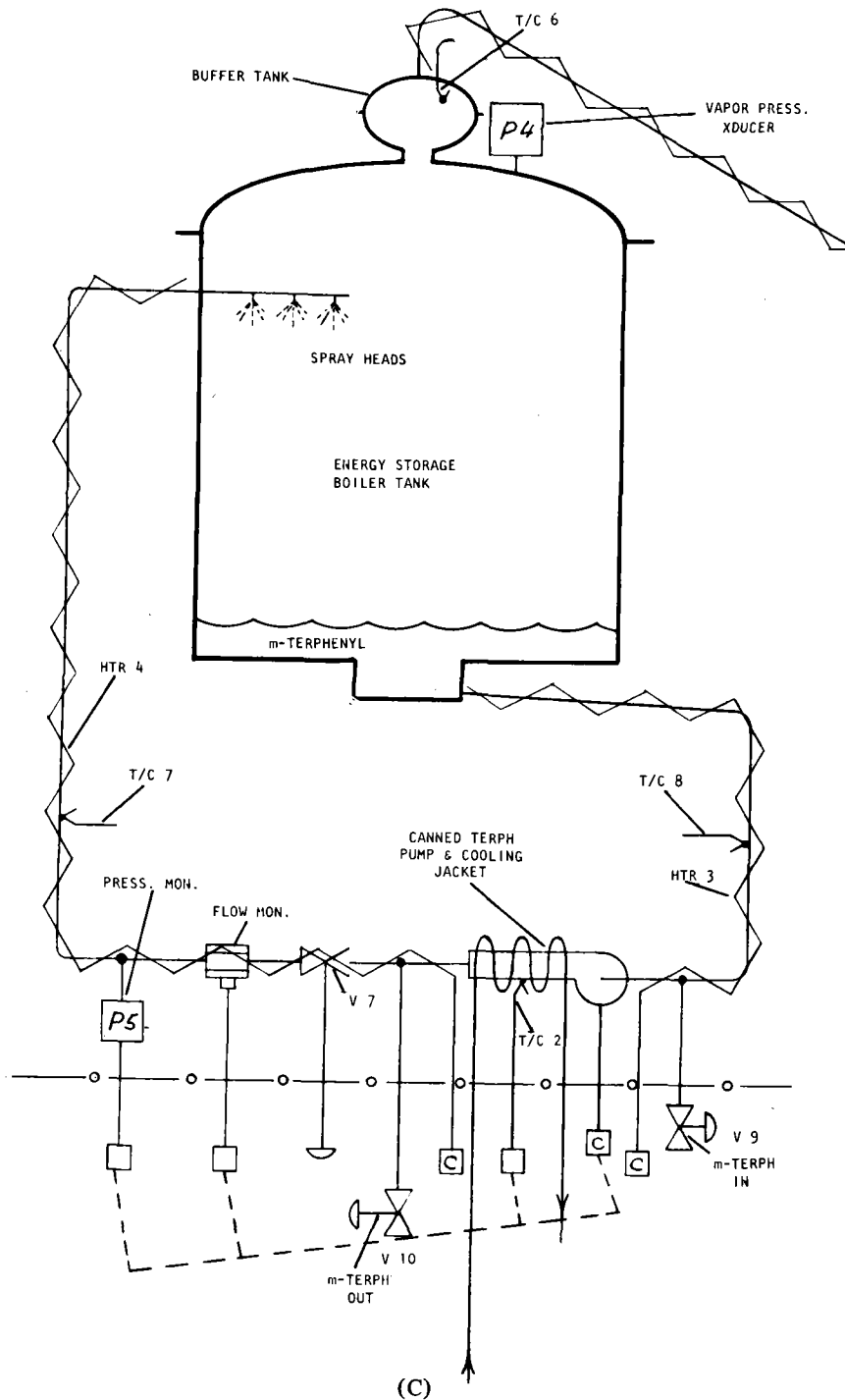
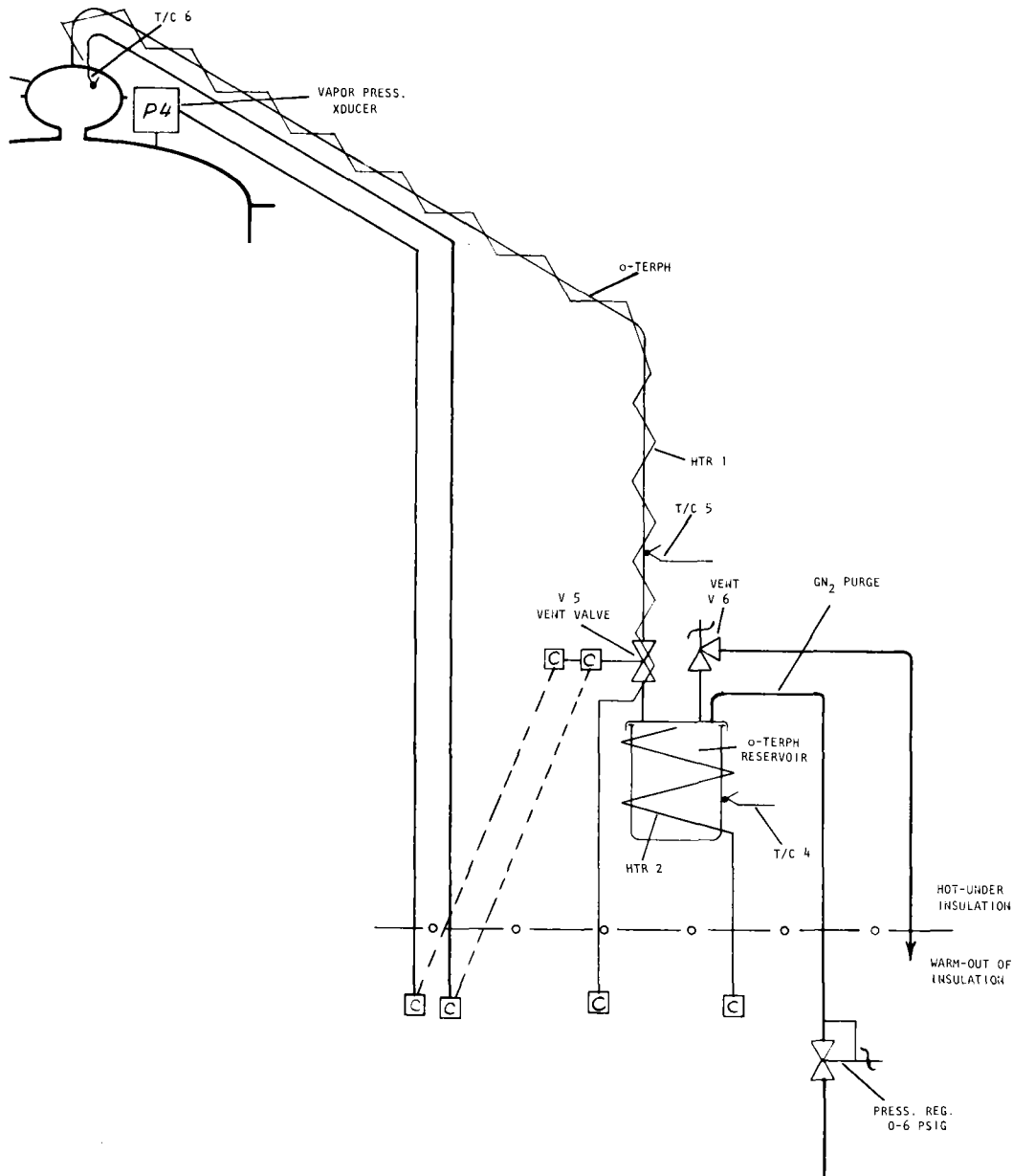

Figure 20C shows the main terphenyl circulation loop which provides hot terphenyl to shower heads within the energy storage boiler tank, as used for withdrawal of energy from storage. Liquid m-terphenyl within the sump in the bottom of the energy storage tank flows under gravity head to the terphenyl circulation pump through an electrically heat-traced line. The pump outflow is piped through an electrically heat-traced line which enters the energy storage boiler tank just below the flanged dome of the tank. The fluid sprays over the salt cans, and excess fluid not-evaporated from the cans' surfaces flows down the cans, joining the pool of fluid in the bottom of the tank. Drain valve V-9, shut-off valve V-7, flow meters and pressure gauges complete the loop. The glycol heating-cooling coil within the terphenyl pump is also indicated. The main terphenyl circulation loop lies fully within the Dacotherm-Foamglas blanket surrounding the energy storage tank.



(D)

Fig. 20D shows the terphenyl bleed system. This system collects high vapor pressure fractions contaminating the m-terphenyl fluid and removes them from the tank. The input to the bleed system is a small buffer tank mounted to the dome of the energy storage boiler tank. This buffer tank is typically a few degrees cooler than the main tank. M-terphenyl condenses within this buffer tank and is returned by gravity liquid feed to the main tank. O-terphenyl and other higher vapor pressure fractions accumulate as vapor within the buffer tank. When the vent valve V5 is opened, these vapor fractions flow under pressure gradient through a heat traced line and exhaust at near ambient pressure into a warm collection tank in which they condense. The vented fluid is stored as a liquid until sufficient material is accumulated to be drained into drums for subsequent disposal. A blanket of nitrogen gas covers the collection tank. Gas effluent is filtered prior to exhausting to the atmosphere.

### 7. Insulation Transport Loop

The insulation around the sides and top of the energy storage-boiler tank is Dacotherm. Vermiculite was similarly used in the laboratory test tank. The Dacotherm is a free flowing sodium silicate bead and is removable to a storage building. Removal is effected by a high flow rate, low-pressure "vacuum cleaner" and air flow delivery system, which is powered by two transvector air drives. The transvectors, which give a 20:1 air flow multiplication, are powered in turn by a large air compressor. The Dacotherm transport system is designed to transport Dacotherm back and forth between a Butler building and the insulation space between concrete retainer walls and the energy storage tank. The Dacotherm transport loop is a desirable feature for a developmental test tank, since it makes it possible to quickly remove the insulation blanket to permit modification and repair. The insulation K value at 200°C is listed at  $K = 0.57 \text{ BTU h}^{-1}\text{ft}^{-2} (\text{F}^\circ/\text{in})^{-1}$ , i.e.,  $k = .083 \text{ W m}^{-1}\text{K}^{-1}$ . Sloping metal ducts (rather than plastic) are used for transport to permit handling Dacotherm while still hot and to reduce electrostatic build-up.

### 8. Site Plans

The 2 MWht energy storage boiler tank is being constructed on the grounds of the Naval Research Laboratory in Washington, D.C. The site is the location of an old powder magazine, and the concrete base of the old powder magazine serves as the support base for the energy storage tank. Similarly the concrete retaining wall which provided the interior support for the bunker surrounding the magazine is being kept to serve as the retainer wall for the Dacotherm insulation that will surround the tank.

The site is configured so as to permit construction of two storage tanks. Figure 21 shows a top view of the overall site. A gantry crane riding on parallel rails services the tanks. The Butler building, which holds the Dacotherm prior to tank turn-on, is adjacent to the tank area.



Fig. 21 — Aerial view of energy storage boiler tank at the Naval Research Laboratory. The storage tank is located inside the square structure closest to the river. An adjacent Butler building provides storage for Dacotherm insulation, which can be removed from around the hot tank to facilitate repairs or alterations. An instrument trailer is located next to the facility to process data and to relay information to a nearby laboratory building. The storage facility is serviced by a lightweight gantry crane. The layout permits construction of a second experimental tank at the same site.

## VI. STATUS OF THE PROOF-OF-CONCEPT STUDY

As of January 1980, work on the energy storage boiler tank site is complete. Power lines providing 150 kW of 3  $\emptyset$  power run from a local building to junction boxes adjacent to the tank pad. A purified water supply for the boiler has also been supplied. Feedwater and terphenyl pumps have been received, as well as Foamglas and Dacotherm insulation. The pressure containment vessel is under construction. The electrical heater elements and feedthroughs have been received. The heater elements have been encapsulated in aluminum castings. Initial heat transfer tests are expected to begin around the middle of the year.

## REFERENCES

1. J.J. Nemecek, D.E. Simmons and T.A. Chubb, "Demand Sensitive Energy Storage in Molten Salts," *Solar Energy* 20, 213 (1978).
2. G.J. Smith, C.L. Jones, W.C. Culbertson, G.E. Erickson and J.R. Dyni, "Evaporites and Brines," *United States Mineral Resources*, edit by D.A. Brobst and W.P. Pratt, *Geologic Survey Professional Paper 820* (U.S. Government Printing Office, Washington, D.C. 1973), p. 197.
3. T.A. Chubb, "Analysis of Gas Dissociation Solar Thermal Power System," *Solar Energy* 17, 129 (1975).
4. T.A. Chubb, J.J. Nemecek and D.E. Simmons, "Application of Chemical Engineering to Large Scale Solar Energy," *Solar Energy* 23, 219 (1978).
5. T.A. Chubb, "Solchem, a Chemical Approach to Solar Energy," *CHEMTECH* 6, 654 (1976).

6. P.O. Carden, "Energy Corradiation Using the Reversible Ammonia Reaction," *Solar Energy* 19, 365 (1977).
7. Reichert, J.D. "Solar Energy Storage Using Chemical Bond Heat Capacity", Report to the Texas Tech Institute for University Research, 1974.
8. E.M. Levin et al., "Phase Diagrams for Ceramists," compiled by National Bureau of Standards, M.K. Reser, Editor, (The American Ceramic Society, Columbus, Ohio, 1964). Also 1975 Supplement and 1979 Supplement.
9. G.J. Janz, C.B. Allen, N.P. Bansal, R.M. Murphy and R.P.T. Tomkins, "Physical Properties Data Compilations Relevant to Energy Storage, II. Molten Salts: Data on Single and Multicomponent Salt Systems," NSRDS-NBS 61, Part II, (U.S. Government Printing Office, Washington, D.C. (1979), Stock No. 003-003-02051-6) p. 285.
10. 1975 The U.S. Fact Book, *Statistical Abstract of the United States*, 95th edition, prepared by Bureau of the Census, (Grosset and Dunlap, New York) p. 660.
11. G.W. Morey and J.S. Burlew, "Studies of Solubility in Systems Containing Alkali and Water, IV. The Field of Sodium Hydroxide in the System Sodium Hydroxide—Sodium Carbonate-Water", *J. Phys. Chem.*, 68, 1706 (1964).
12. H.C. Maru, J.F. Dullea, A. Kardas and L. Paul, "Molten Salt Thermal Energy Storage Systems," *Project 8981 Final Report* (Institute of Gas Technology, Chicago, IL, 1978) p. 13.
13. T.A. Chubb, "Energy Storage Tank", *Report on the Symposium and Workshop on the 5 MWt Solar Thermal Test Facility, May 17-19, 1976*, Houston, Texas, ALO/3701-76/1, (University of Houston and Texas Tech., 1976, available through NTIS, Springfield, VA) p. 241.



CHUBB, NEMECEK, AND SIMMONS

14. P.L. Geiringer, "Handbook of Heat Transfer Media." (R.E. Krieger, Huntington, NY, 1977) p. 173.
15. See Appendix F.
16. E. Janecke, "Uber das Schmelz-und Erstarrungsbild des Doppelt-Ternaren Systemes (K<sub>2</sub>Na<sub>2</sub>Mg) (Cl<sub>2</sub>SO<sub>4</sub>)," *Z. Anorg. Allgem. Chem.* 261, 218 (1950).
17. C.E. Moeller and E. Rush, "High Pressure Steam Generation at 5 MW Solar Thermal Test Facility", *Proc. of the 1978 Annual Meeting, American Section of the International Solar Energy Society, Vol. 2.1*, 811 (1978).

## Appendix A

### CHEMICAL VS. THERMAL STORAGE FOR THERMOCHEMICAL SOLAR POWER SYSTEMS

The main use of heat-of-fusion energy storage systems is expected to be that of providing diurnal energy storage for solar thermal power plants. Delivery of energy to a storage area from several or more solar energy collectors involves intermediate distance energy transport. The best means of providing intermediate distance energy transport is the closed cycle thermochemical energy transport loop. The question then arises, why use latent heat-of-fusion energy storage tanks instead of storing some of the chemical inventory to provide energy storage? This appendix addresses the trade-off, chemical vs. thermal storage, for thermochemical solar power systems.

The first point to note is that both heat-of-fusion and chemical storage are likely to be used in many systems. In some systems heat-of-fusion storage should dominate; in others chemical storage should dominate. If the main storage need is seasonal, if the thermochemical energy transport system is the high pressure (200-400 atm)  $\text{NH}_3 \rightleftharpoons \frac{1}{2} \text{N}_2 + \frac{3}{2} \text{H}_2$  cycle, and if a suitable geologic gas trap connected to the surface with a hydrostatic head<sup>(1)</sup> exists at a depth of 6800-13,600 feet, then storage of compressed  $\text{N}_2 + \text{H}_2$  in the trap is a preferred solution. If the main storage need is diurnal, if high peak power demands are required, and if the thermochemical energy transport system is the low pressure (4-8 atm)  $3 \text{CO}_2 + \text{CH}_4 \rightleftharpoons 2 \text{CO}_2 + 2 \text{CO} + 2 \text{H}_2$  cycle, then heat-of-fusion storage tanks appear to be the preferred storage means.

The first thermochemical solar power system analyzed made use of the  $\text{SO}_3 \rightleftharpoons \text{SO}_2 + \frac{1}{2} \text{O}_2$  chemical cycle to carry energy to a central storage area. This system operated

isobarically at 3 atmospheres and delivered energy at  $\sim 500^{\circ}\text{C}$ . It operated in a pure gas phase. The thermochemical system operated between 5.8%  $\text{SO}_3$  dissociation and 77.4%  $\text{SO}_3$  dissociation. In Table A-1 we compare the storage volume requirements for 2 MWht of energy storage. Chemical gas storage is compared with heat-of-fusion storage, based on use of an energy storage boiler tank with  $\text{MgCl}_2$ ,  $\text{NaCl}$ ,  $\text{KCl}$  as the heat-of-fusion storage medium. Gas volumes are between 36 and 45 X the volume required for salt storage, depending on whether or not inert ullage gas is used for pressure maintenance.

TABLE A-1  
Energy Storage Boiler Tank vs Chemical Inventory Tank

Item	2 MWht Energy Storage Boiler Tank	Chemical Inventory Tank
Tank Contents	4000 cans containing salt, heater, heat transfer fluid, condensation boiler	Top: 16% $\text{SO}_3$ , 56% $\text{SO}_2$ 28% $\text{O}_2$ ; Separation Membrane; Bottom: 92% $\text{SO}_3$ 6% $\text{SO}_2$ , 3% $\text{O}_2$
Temperature	$385^{\circ}\text{C}$	$70^{\circ}\text{C}$
Pressure	0-1 atm gauge	2 atm gauge
Volume for 1.82 MWht	$33.5 \text{ m}^3$ (1183 $\text{ft}^3$ )	
Energy Storage Density	.054 MWht $\text{m}^{-3}$	.0015 MWht $\text{m}^{-3}$
Volume for 1 MWht	$18.4 \text{ m}^3$ (650 $\text{ft}^3$ )	$664 \text{ m}^3$ (23500 $\text{ft}^3$ )*

\* An additional  $173 \text{ m}^3$  of inert gas storage in constant pressure seal tankage may be required to provide ullage for operation of an isobaric system, since the volume of working gas varies by 26% from fully energized storage to fully depleted storage.

An alternative to storing  $\text{SO}_3$  and  $\text{SO}_2$  as gases is to store  $\text{SO}_3$  and  $\text{SO}_2$  as liquids. Liquid storage requires separation of both sulfur chemicals from gaseous  $\text{O}_2$ , which must be stored separately as a compressed gas. The volume required for  $\text{O}_2$  storage is 24% of that required for

full gas storage, based on storage at 3 atm and 20°C. However, liquification of SO<sub>3</sub> releases vast amounts of low temperature heat, which must be resupplied when SO<sub>3</sub> is revaporized. Since the heat of vaporization (9.5 kcal mol<sup>-1</sup>) is 40% of the heat of dissociation (23.5 kcal mol<sup>-1</sup>) and since somewhat more SO<sub>3</sub> must be evaporated each storage cycle that gets dissociated, evaporation energy requirements are 43% of heat delivery requirements. Thus a substantial energy storage inefficiency is introduced into the storage process unless effective use can be made of SO<sub>3</sub> heat-of-condensation in a total energy application. Energy storage systems which use SO<sub>x</sub> stored in liquid form and which do not make use of the large quantities of low-grade heat available have low efficiencies.

The design of boilers for removal of stored energy at high rates appears to be easier with the energy storage boiler tank than with catalytic chemical reactors. The exothermic reaction boilers involving  $\text{SO}_2 + \frac{1}{2} \text{O}_2 \rightarrow \text{SO}_3$ , for example, place the boiler in a corrosive environment, subject it to temperature cycling, have the potential for overheat and could involve heat transfer problems because of the poor thermal conductivity of SO<sub>3</sub>. In contrast, the condensation boilers of the energy storage boiler tank provide excellent heat transfer to the boiler, limit temperature cycling to relatively small values and cannot overheat the boilers. The steam produced is the major corrosive element.

Another consideration is the following:

The storage of energy in the form of SO<sub>2</sub>, SO<sub>3</sub>, and O<sub>2</sub> involves large sulfur oxide inventories. Twenty-four-hour storage for a 100 MWe plant would likely require storage of about 7200 MWht. The corresponding sulfur oxide inventory would be 31,000 tons. This large inventory contrasts with the small inventory required for thermochemical energy transport. For a thermochemical solar power plant the typical chemical cycling time is about three minutes.

Since the duty cycle for energy collection is  $\sim 33\%$  (eight hours per day), the  $\text{SO}_x$  inventory is 160 times less than that required for chemical storage. Thus use of heat-of-fusion energy storage instead of chemical energy storage in an  $\text{SO}_x$  thermochemical solar power plant reduces  $\text{SO}_x$  inventory by more than two orders of magnitude.

The considerations expressed above are obviously chemical cycle dependent. Innovative engineering design can affect the trade-offs between storage concepts. Any value judgment made today must be reconsidered in light of future experience.

#### REFERENCES

- A1. Owen Williams, private communication.

## Appendix B

### SALT COST CALCULATIONS COST ESTIMATE FOR $\text{MgCl}_2$ , $\text{NaCl}$ , $\text{KCl}$ EUTECTIC, AND OTHER SELECTED EUTECTICS

The major and irreducible mass component in energy storage tanks using heat-of-fusion as the storage mechanism is the storage salt itself. Should major use of heat-of-fusion storage come into being, salt usage will be on an enormous scale. Even early usage would be expected to be at a rate of more than 20,000 T per year.

The salt cost problem must be approached in several ways. One approach is to obtain cost estimates from manufacturers of magnesium flux as used in the magnesium metal industry. The magnesium flux salts are produced in commercially available continuous melt furnaces. The product is dry enough for use as an energy storage material. This costing approach has been pursued by presenting to a magnesium flux manufacturer the following problem: Assume that you have a 20 year guaranteed market for 20,000 tons per year of  $\text{MgCl}_2$ ,  $\text{NaCl}$ ,  $\text{KCl}$  eutectic, at what price could you deliver this product in 4" diameter cans 19" high? The location of the plant is your choice. The cans can be loaded either with liquid or with flaked salt delivered to the cans over a short dry line. Mr. Scholtz has replied to this inquiry and his letter is attached as part of this Appendix. His price is \$370  $\text{ton}^{-1}$ .

Production of really large tonnages of eutectic salt will likely be based on different technologies than these currently employed. For these larger tonnages, raw material costs and energy costs associated with dehydration should be the major contributions to the cost of the final product. The value of the raw salt materials are derived from 1979 quotes as follows:

TABLE B-1  
Raw Salt Cost

Material	1979 Value (\$ ton <sup>-1</sup> )
NaCl <sup>(1)</sup>	9.45
MgCl <sub>2</sub> in 34% Brine <sup>(2)</sup>	22.50
KCl <sup>(3)</sup>	67.10

(1) Pacific Salt Co., City of Industry, CA

(2) Great Salt Lake Mineral Co., Salt Lake City, UT

(3) Kerr McGee Chemical, Los Angeles, CA

The MgCl<sub>2</sub>, NaCl, KCl is ~55.0% MgCl<sub>2</sub>, 24.5% NaCl, 20.5% KCl by weight.

The salt raw material making up this eutectic must be dried, mixed, melted, dehydrated and containerized before use. The main cost is that of dehydrating MgCl<sub>2</sub> solution. MgCl<sub>2</sub> · 6H<sub>2</sub>O is 47% MgCl<sub>2</sub>, i.e., it contains 1.13 lb of H<sub>2</sub>O per lb of MgCl<sub>2</sub>. A 34% solution contains 1.94 lb of H<sub>2</sub>O per lb of MgCl<sub>2</sub>. Dehydration of 34% solution should be less costly than 1.72 × the cost of dehydrating MgCl<sub>2</sub> · 6H<sub>2</sub>O. Part of dehydration can be effected by heating; however, the final portion of hydration water must be removed during melt processing of the salt. This final step is carried out in a continuous melt furnace in which heat is derived from electric currents passed between internal electrodes and the walls of the melt furnace. Electrolysis is believed responsible for removal of the most tightly held water.

We approximate the cost of salt preparation by assuming that electric heating is used to meet the full energy requirement for dehydrating, heating and melting the salt. We assume that additional costs involved in making up for thermal losses, in mixing and in otherwise handling the salt are compensated for by the savings that could be achieved by using process heat for the easier portions of the dehydration process. In calculating the energy required for dehydration, we overestimate as follows: A 34% MgCl<sub>2</sub> solution contains 1.94 lbs of H<sub>2</sub>O per lb of

MgCl<sub>2</sub>. The hexahydrate MgCl<sub>2</sub> · 6H<sub>2</sub>O contains 1.13 lb of H<sub>2</sub>O per lb of MgCl<sub>2</sub>. We overestimate the energy requirement for salt preparation by assuming that the energy required to convert 34% MgCl<sub>2</sub> solution to hexahydrate is 72% of the requirement for hexahydrate dehydration. The energy requirements are given in Table B-2.

TABLE B-2  
Energy Costs of Dehydration

For MgCl<sub>2</sub>:

Dehydration energy<sup>(1)</sup> MgCl<sub>2</sub> · 6 H<sub>2</sub>O → MgCl<sub>2</sub> + 6 H<sub>2</sub>O(g)

$$96.2 \text{ kcal mole}^{-1} \Rightarrow 1010 \text{ cal gm}^{-1}$$

Conversion of 34% MgCl<sub>2</sub> solution to MgCl<sub>2</sub> · 6 H<sub>2</sub>O,

$$72\% \text{ of } 1010 \text{ cal gm}^{-1} \Rightarrow \underline{727 \text{ cal gm}^{-1}}$$

Total energy cost for dehydration of 34% MgCl<sub>2</sub> solution:

$$1737 \text{ cal gm}^{-1}$$

For Salt Eutectic:

$$\text{Dehydration energy: } 55\% \times 1737 \text{ cal gm}^{-1} = 955.5 \text{ cal gm}^{-1}$$

$$\text{Energy to melt eutectic (Dynatech value)} = 057.3 \text{ cal gm}^{-1}$$

$$\text{Energy to heat salt } = 110.0 \text{ cal gm}^{-1}$$

20° → 500°C (Based on  
480/365 × ΔH 20° →  
385°C, as measured  
by Dynatech)<sup>(2)</sup>

$$\text{Total energy cost of dehydration} = \underline{1122.8 \text{ cal gm}^{-1}}$$

We can now calculate the cost of preparing the salt eutectic:

Value of electricity to dehydrate and melt salts

$$C = \frac{1122.8 \times 4.186 \times 10^6}{10^3 \times 3600} \times .046 = 60.1 \text{ \$ tonne}^{-1} = 54.6 \text{ \$ ton}^{-1}$$

where .046 \$ kWh<sup>-1</sup> is July 1979 electricity cost at NRL.



Adding raw material cost, the total cost of dehydrated salt = 83 \$ ton<sup>-1</sup>, as shown in Table B-3.

TABLE B-3  
Breakdown of Salt Costs (MgCl<sub>2</sub>, NaCl, KCl Eutectic)

Material	1979 Value (\$ ton <sup>-1</sup> )	Contribution to Eutectic Costs (\$ ton <sup>-1</sup> eutectic)
NaCl	\$9.45	2.3
MgCl <sub>2</sub>	\$22.50 (in 34% solution)	12.4
KCl	67.1	13.8
Drying of solution		19.4
Dehydration cost		27.0
Heating, melting cost		8.1
Total cost of salt		83.0

A third approach to estimating salt costs is to use the costs quoted on the single significant size order for containerized salts. (Containers provided by NRL). We expect that an order for 30 tons of containerized eutectic will be soon placed for a cost of \$ 12000. The salt cost will come to \$ 400 ton<sup>-1</sup>.

#### Eutectics Made from NaCl, CaCl<sub>2</sub>, Na<sub>2</sub>CO<sub>3</sub>, Na<sub>2</sub>SO<sub>4</sub> and NaOH

Raw salt costs for eutectics derived from NaCl, CaCl<sub>2</sub>, Na<sub>2</sub>CO<sub>3</sub>, Na<sub>2</sub>SO<sub>4</sub>, and NaOH are as follows:

TABLE B-4  
Raw Salt Cost

Material	Source	1979 Quote (\$ Ton <sup>-1</sup> )
NaCl	Pacific Salt Company	9.45
CaCl <sub>2</sub>	Dow Chemical Company (Dow Flake, 78% CaCl <sub>2</sub> quoted @ 117 \$ ton <sup>-1</sup> ) (Drying cost estimate @ 9.00 \$ ton <sup>-1</sup> )	159.00
Na <sub>2</sub> CO <sub>3</sub>	Kerr McGee Quote (1979)	77.25
Na <sub>2</sub> SO <sub>4</sub>	Kerr McGee Quote (1979)	62.00
NaOH	Comstock & Wescott, Inc. estimate for a 30-ton lot	500.00

The  $\text{CaCl}_2$ ,  $\text{NaCl}$  eutectic is 68%  $\text{CaCl}_2$ , 32%  $\text{NaCl}$  by weight.<sup>(3)</sup> The raw material cost is 111 \$  $\text{ton}^{-1}$  (1979). The  $\text{NaCl}$ ,  $\text{Na}_2\text{CO}_3$  eutectic is 43%  $\text{NaCl}$ , 57%  $\text{Na}_2\text{CO}_3$  by weight.<sup>(4)</sup> The raw material cost is 48 \$  $\text{ton}^{-1}$  (1979). The  $\text{Na}_2\text{SO}_4$ ,  $\text{NaCl}$  eutectic is 69%  $\text{Na}_2\text{SO}_4$ , 31%  $\text{NaCl}$  by weight.<sup>(3)</sup> The raw material cost is 46 \$  $\text{ton}^{-1}$ . The  $\text{NaOH}$ ,  $\text{Na}_2\text{CO}_3$  eutectic is 81.5%  $\text{NaOH}$ , 18.5%  $\text{Na}_2\text{CO}_3$  by weight.<sup>(5)</sup> The cost estimate based on producing the eutectic by mixing  $\text{Na}_2\text{CO}_3$  and  $\text{NaOH}$  is 422 \$  $\text{ton}^{-1}$ . However, mixes of  $\text{Na}_2\text{CO}_3$  is  $\text{NaOH}$  in the above concentration range can be made by mixing  $\text{Na}_2\text{CO}_3$  with slaked lime:  $\text{Na}_2\text{CO}_3 + \text{Ca}(\text{OH})_2 \rightarrow \text{CaCO}_3 + 2 \text{NaOH}$ . In this process  $\text{NaOH}$  is produced from  $\text{Na}_2\text{CO}_3$  at the rate of .755 lb of  $\text{NaOH}$  per lb of  $\text{Na}_2\text{CO}_3$  converted, corresponding to a  $\text{Na}_2\text{CO}_3$  cost of 102 \$ per ton of  $\text{NaOH}$ . Costs of  $\text{Ca}(\text{OH})_2$  processing and dehydration costs must be added. With these additions it is guessed that the  $\text{NaOH}$ ,  $\text{Na}_2\text{CO}_3$  eutectic would cost much less than the 422 \$  $\text{ton}^{-1}$  estimated above.

#### REFERENCES

- B1. *Handbook of Chemistry and Physics, 40th Edition*, C.D. Hogman editor, (Chemical Rubber Publishing Co., Cleveland, OH) pp 1802-1805 (1958).
- B2. See Appendix C, this paper
- B3. Janz, G.J., Allen, C.B., Downey, J.R., Jr., and Tompkins, R.P.T., "Physical Properties Data Compilations Relevant to Energy Storage. I Molten Salts: Eutectic Data." NSRDS-NBS 61, Part 1, 5D Catalog No. C13.48:61, Part 1 (U.S. Government Printing Office, Washington, DC, 1978). (Composition of  $\text{NaCl}$ ,  $\text{Na}_2\text{CO}_3$  eutectic is incorrect in this reference.)
- B4. E.M. Levin, C.R. Robbins, and H.F. McMurdie, "Phase Diagrams for Ceramists," (American Ceramic Society, Columbus, OH, 1964). Also 1969 Supplement and 1975 Supplement, e.g., see Fig. 3751.
- B5. G.W. Morey and J.S. Burlew, *J. Chem. Phys.* 68, 1706 (1964).

CHUBB, NEMECEK, AND SIMMONS

**SRC INC.**

DIVISION OF ROSSBOROUGH SUPPLY



3425 SERVICE RD.  
CLEVELAND, OHIO 44111  
216-941-6115

2920 ARNOLD N.E.  
ALBANY, OREGON 97321  
503-928-1624

**MANUFACTURERS OF PRODUCTS FOR CONTROLLED MOLTEN METALS**

September 12, 1979

Mr. Talbot Chubb  
Naval Research Laboratory  
Design Engineering Section  
Space Science Division  
Code 7120  
Washington, D.C. 20375

Dear Mr. Chubb,

The following are rates and terms for the eutectic salt mixture you requested.

This mixture could be produced for \$.185 per pound, with the price being subject to magnesium metal price index. Terms are FOB at the location of our plant. The mixture can be cast in solid or granular form, into containers provided by the customer. This quote is subject to product availability at the time of order.

We hope these rates and terms are acceptable to you. We thank you for your interest in SRC, Incorporated, and look forward to doing business with you in the future.

Sincerely,

SRC, INCORPORATED

*Chet B. Scholtz*  
Chet B. Scholtz  
President

CBS:bj

### **Appendix C**

#### **MEASUREMENT OF HEAT-OF-FUSION OF $\text{MgCl}_2$ , NaCl, KCl EUTECTIC**

The heat-of-fusion of  $\text{MgCl}_2$ , NaCl, KCl eutectic was measured by Dynatech Corporation to be  $240 \text{ J gm}^{-1}$ . The test eutectic material was prepared by NRL and was poured into a special container provided by Dynatech. The measurement was performed in a drop calorimeter.

R. W. Carling of Sandia Laboratories carried out a differential calorimeter study on a eutectic sample, again provided by NRL. Carling's data provides a check on the Dynatech measurement.

The Dynatech report and Carling's letter follow.



Report on

THE SPECIFIC HEAT OF  
A EUTECTIC MATERIAL

For: Naval REsearch Laboratory  
Washington, DC 20375

A material described as a eutectic salt was submitted for analysis of the specific heat and the latent heat of melt. The melting point was given as 385C.

Experimental Procedure

The material was supplied in a sealed aluminum container. A blank empty container was submitted for determination of the container enthalpy.

The enthalpy was determined using the high temperature drop calorimeter. The container was attached to a 0.3 mm platinum support wire and suspended vertically at the center of a three-zone controlled temperature furnace with the free end of the wire passing over a free moving pulley at the top of the furnace. Two thermocouples were suspended from the top of the furnace such that the junctions touched the container near the top and bottom. The wire was so arranged that the container was suspended vertically along the center line of the furnace and of such a length that when it came to rest at the end of its travel the container rested upon the base of the receiver below it.

The container was allowed to attain the equilibrium temperature for a period of time usually the order of 1 - 2 hours and regular readings of the temperature measurement thermocouples taken. During the thirty minutes prior to a "drop" the temperature of the receiver was noted every 30 s. At a given time when the two thermocouples and the very small drift in temperature of the receiver had been noted, the container was dropped quickly. As the container dropped the radiation shields covering the intermediate zone moved sideways to allow the container to fall and come to rest

Reference: NAV-24

April, 1978



in the receiver. When the container came to rest, these shields quickly returned to the original position in order to reduce any radiation transfer of heat from the furnace to the receiver or convective and radiant heat transfer from the receiver to the outside.

The temperature of the copper receiver was taken regularly at 30 s intervals for the first thirty minutes following the drop followed by 60 s intervals for the next thirty to sixty minutes in order to determine the rise in temperature and the subsequent drift in temperature of the receiver. Following a drop, the receiver system was allowed to come to equilibrium for the order of two hours.

The calculation technique was as follows.

The enthalpy of the empty aluminum container per unit mass was determined from

$$\Delta H_a (T_s - T_f) = \frac{(mC)_r (T_f - T_i)}{M_a}$$

where

- $\Delta H_a$  = enthalpy of empty aluminum container from  $T_s - T_f$
- $T_s$  = temperature of aluminum container in furnace prior to drop
- $T_f$  = final receiver temperature after drop
- $T_i$  = initial receiver temperature prior to drop
- $(mC)_r$  = heat capacity of copper receiver from calibration
- $M_a$  = mass of aluminum container

The aluminum container was then dropped from the desired temperatures and the enthalpies of the salt per unit mass calculated from

$$\Delta H_s (T_s - T_i) = (mC)_r (T_f - T_i) - (\Delta H_a) (M_a)$$

Reference: NAV-24

April, 1978



where  $\Delta H_s$  = enthalpy of salt from  $T_s$  to  $T_f$   
 $M_s$  = mass of salt in container

An equation was then fit to the data by computer relating the enthalpy per unit mass of the salt to each drop temperature. The equation was differentiated to yield the specific heat.

The latent heat of melt was determined by subtracting the enthalpy predicted by the equation at 410C to the enthalpy determined during the experimental drop.

The results are given in the following tables.

Table I

THE TOTAL ENTHALPIES OF A  
 EUTECTIC SALT

Furnace Temperature C	Final Temperature C	Enthalpy J kg <sup>-1</sup>
100	20	63x10 <sup>3</sup>
200	20	154x10 <sup>3</sup>
300	20	250x10 <sup>3</sup>
350	20	299x10 <sup>3</sup>
400	20	349x10 <sup>3</sup>
410	20	599x10 <sup>3</sup>

Latent Heat of Melt =  $240 \times 10^3 \text{ J kg}^{-1}$



Table II

THE SPECIFIC HEAT OF  
A EUTECTIC SALT

Temperature C	Specific Heat $\text{J kg}^{-1}\text{C}^{-1}$
20	860
100	890
200	930
300	970
350	990
400	1010

Reference: NAV-24

April, 1978



CHUBB, NEMECEK, AND SIMMONS

**Sandia Laboratories**

Livermore, California 94550

May 15, 1978

Dr. Talbot A. Chubb  
Head, Upper Air Physics Branch  
Space Science Division  
Naval Research Laboratory  
Washington, D. C. 20375

Dear Dr. Chubb:

I received your eutectic salt (24.5% NaCl, 20.5% KCl, and 55.0% MgCl<sub>2</sub> by weight) and have now determined the temperature and enthalpy of fusion. A sample of the salt was sealed in a gold capsule and the measurements made on a Perkin-Elmer differential scanning calorimeter, DSC-2. Several scans were made at different sensitivities to assure reproducibility of both the melting temperature and enthalpy. The DSC scans showed three temperature effects. They occurred at 332, 381, and 386°C. The low-temperature transition had an enthalpy of 4.4 cal g<sup>-1</sup>. The transitions at 381 and 386°C were too close in temperature to be resolved. They had a enthalpy of 51 cal g<sup>-1</sup>. The sum of the two enthalpies is 55 cal g<sup>-1</sup> which compares favorably with the value reported by Dynatech (57 cal g<sup>-1</sup>). No attempt was made to determine the cause of each observed transition; to do so would require a fairly comprehensive phase diagram study.

If I can be of further service let me know.

Sincerely,



R. W. Carling  
Exploratory Chemistry Division I

RWC:8313:db

## **Appendix D**

### **DESIGN OF CONDENSATION BOILERS AND SUPERHEATERS**

Design studies preliminary to the construction of the 2 MWh energy storage boiler tank lead to the preparation of several short progress reports. The progress report<sup>(1)</sup> attached hereto was published as part of the proceedings of the 1977 ISES meeting. It describes the principles used in designing condensation boilers. It also describes the initial boiler design, which has only been slightly modified for the 2 MWh tank. Figures 13 and 15 were developed as part of this study.

### **REFERENCES**

- D1. Chubb, T.A., J.J. Nemecek, and D.E. Simmons, "Energy Storage-Boiler Tank: Boiler Design, Materials Compatibility Tests," Proceedings of the 1977 Annual Meeting of the American Section of the International Solar Energy Society.

CHUBB, NEMECEK, AND SIMMONS

ENERGY STORAGE-BOILER TANK: BOILER DESIGN, MATERIALS COMPATIBILITY TESTS

T.A. Chubb, J.J. Nemecek, and D.E. Simmons  
 E. O. Hulburt Center for Space Research  
 Naval Research Laboratory  
 Washington, D. C. 20375

ABSTRACT

The energy storage-boiler tank is an energy storage device in which heat is stored as heat-of-fusion and in which heat transfer is effected by condensation and evaporation of a heat transfer fluid. An economizer-boiler and superheater have been designed for a 2 MWh storage tank. Calculations indicate that output steam temperature will drop 9°C as steam power output is increased from .15-0.3 MW. Materials studies indicate that NaCl, KCl, MgCl<sub>2</sub> eutectic is compatible with low alloy steel and aluminum if thoroughly dry. Heat transfer fluid m-terphenyl has been refluxed for 6-months without excessive change in boiling point in an oxygen-free N<sub>2</sub> atmosphere.

The energy storage-boiler tank<sup>(1)</sup> is a device which promises to provide both energy storage and on-demand steam. Plans are underway to build a storage tank with a capacity of 2 MWh (thermal). The tank will use about 24 tons of NaCl, KCl, MgCl<sub>2</sub> eutectic as a heat-of-fusion storage medium. Energy storage will occur at the eutectic melting point of 385°C. The salt will be packaged in containers of 10 cm diameter. Evaporation and condensation of m-terphenyl will provide energy transport onto, and away from, the surfaces of the salt cans. Primary energy input will be by means of a 150 kW electric heater.

Present plans are to generate steam in the storage tank by means of a set of 8 parallel boilers located inside a domed lid that forms the top of the storage tank. Each boiler will be a tube 15 cm OD x 244 cm long. The boilers receive feed water from short headers that pass through the tank lid. Heat is applied to the boiler by means of condensation of m-terphenyl vapor. This vapor fills the tank to a pressure somewhat above 1 atmosphere absolute. Condensation maintains the outside surface of a thin layer of liquid terphenyl at a temperature corresponding to the vapor pressure of m-terphenyl within the tank. This temperature is assumed to be 375°C. Temperature drop through the liquid film limits heat flow into the boiler, whereas rapid agitation of boiling waters cause

the temperature drop from the interior wall of the boiler into the boiling liquid to be small. The thickness *t* of the liquid m-terphenyl film is determined by the condensation rate, the viscosity of the fluid, and the force of gravity<sup>(2)</sup>

$$\bar{t} = 1.4 \left( \frac{D \mu \Delta T k}{\rho^2 g h} \right)^{\frac{1}{4}}$$

where *D* is the pipe diameter (horizontal pipe),  
*μ* is the viscosity of m-terphenyl,  
 $\Delta T$  is the temperature drop across the film,  
*k* is the thermal conductivity of liquid m-terphenyl,  
*ρ* is the density of liquid m-terphenyl (vapor density assumed to be negligible),  
*g* is acceleration of gravity,  
*h* is latent heat of vaporization per unit mass of m-terphenyl.

In the design of the boiler, it appears to be important not to quench the agitation of the boiling water by introduction of feed water at temperatures substantially below the boiling point. This situation can be avoided by providing a coaxial feed-water pipe within the boiler such that the incoming water is heated by steam condensation prior to being permitted to join the pool of boiling liquid at the bottom of the boiler. Heat transfer in this feedwater input is limited by heat transfer from the inside wall of the feedwater pipe into the moving feedwater. With a feedwater pipe of 0.95 cm ID, a length of 230 cm is sufficient to raise the feedwater temperature to within 20°C of the boiling temperature. As presently designed 8 parallel boilers feed a common steam header that delivers steam to a set of 4 parallel superheater lines. Heat transfer in the superheater is limited mostly by the heat transfer rate between pipe interior and the moving steam gas. With 3.8 cm ID pipes, each 6 m in length, an outlet steam temperature of 362°C at 5.52 MPa (800 psia) is calculated for a 150 kW heat withdrawal rate. At 300 kW heat withdrawal rate, an exit temperature

## NRL MEMORANDUM REPORT 4267

of 353°C is calculated. It appears that the boiler-superheater could provide steam at 1000 kW heat withdrawal rate at an exit temperature of 335°C.

Experimental work with materials for the energy storage boiler tank has been largely limited to melt studies with NaCl, KCl, MgCl<sub>2</sub> salts and reflux studies with phenylated compounds in a nitrogen atmosphere. Salts dried by high temperature attack on aluminum shavings appear to be inert toward low alloy steel and aluminum container materials. The one batch of salt prepared by a continuous melt commercial furnace was not as dry as laboratory dried salts, but was nonetheless quite dry and could quite possibly be used without further treatment. (A small amount of H<sub>2</sub> generation and metal etch would be expected.) Of the heat transfer candidates under test, m-terphenyl seems to be the best choice. One batch has been boiled in N<sub>2</sub> for 6 months. Triphenyl amine may also be useable, but it appears to have blackened more than the m-terphenyl. Diphenyl sulfone and triphenyl phosphine oxide were found unsatisfactory at their respective boiling points, tending to char after a few days. Triphenyl phosphine oxide also caught fire.

### REFERENCES

- (1) Chubb, T.A., J.J. Nemecek, and D.E. Simmons, "Application of Chemical Engineering to Large Scale Solar Energy," Proceedings of the Joint Conference 1976 of American Section of International Solar Energy Society and Solar Energy Society of Canada, Winnipeg, Manitoba, CANADA, 15-20 August 1976.
- (2) Kern, D.A., Process Heat Transfer, McGraw-Hill Book Company, Inc., New York, 1950, p. 263.

## Appendix E

### CALCULATIONS RELEVANT TO RADIATION COUPLED ENERGY STORAGE TANK

One configuration of the radiation coupled energy storage tank is shown in Fig. E-1. The figure illustrates how one can use vertical heat pipes to distribute heat to an array of salt containers which serve as an energy storage medium. Coupling energy into, and out of, the heat pipes can be effected by use of a molten metal heat transfer pool, as shown in the figure, or by means of additional horizontal heat pipe elements. In the configuration shown, the heat pipes operate in a gravity assisted mode during heat delivery and operate against gravity during heat withdrawals. Other configurations in which the superheater tubes are placed at the top of the tank can be constructed in which all heat pipes operate with gravity assist.

To show the feasibility of the radiation coupled energy storage tank concept, we calculate heat transfer rates for a 2 MWht tank containing 319 cans six inches in diameter and 10 feet high in the configuration shown in Fig. E-1. We first consider the adequacy of energy transport by radiation alone. We assume that heat pipes are made absorbent in the infrared so as to have  $\alpha = \epsilon = 0.9$ . We also assume that the containers have an effective absorptivity of  $\alpha_{eff} = 0.9$ . Since the total surface area of the cans is 18X the surface area of the heat pipes, no special surface treatment of the cans should be required. We note that each heat pipe is immersed in a black body radiation environment defined by the radiating-absorbing surfaces of the salt containers. We then ask the question, what is the net radiation outflow from the heat pipes when they are 20°C (also 40°C) hotter than the salt cans? Calculations are based on the Stefan-Boltzman law,  $H = \sigma \cdot \epsilon \cdot \alpha_{eff} (T_2^4 - T_1^4)$ .

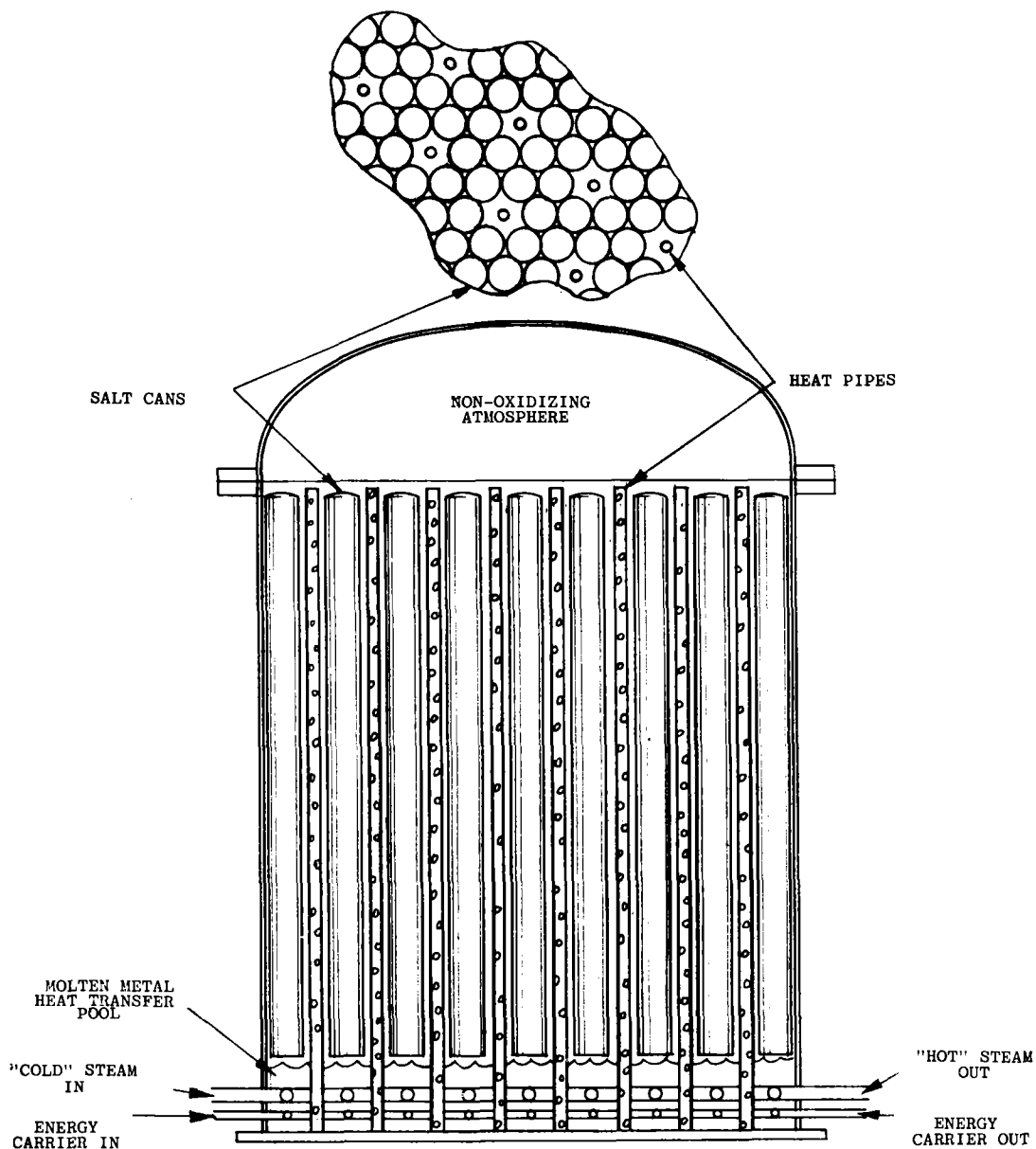

Fig. E-1 — Radiation coupled energy storage tank. Operation is described in caption of Fig. 4. Salt can-heat pipe geometry on which calculations are based consists of hexagons made up of six 6-inch diameter salt cans surrounding single 2-inch diameter potassium vapor heat pipes. The configuration for a 2 MWht tank contains 53 heat pipes with an aggregate area of  $2.6 \times 10^5 \text{ cm}^2$ . The overall tank size is the same as that of the 2 MWht energy storage boiler tank being built at NRL, i.e.,  $\sim 10.5'$  in diameter,  $\sim 15'$  high.

In Table E-1, we show radiation transfer rates as function of temperature. The transfer rates are used to calculate heat flow from and into the heat pipes. The tank shown in Fig. E-1 uses 2" diameter heat pipes surrounded by 6" diameter salt containers. The 10-foot tank contains 53 heat pipes with an aggregate area of  $2.58 \times 10^5 \text{ cm}^2$ . Energy transfer rates are shown in Fig. E-2. The figure shows that heat transfer rates of  $\sim 90$  and  $\sim 140$  kW can be achieved by radiation alone with  $\Delta T = 40^\circ\text{C}$ . The table shows that a  $\Delta T$  of  $40^\circ\text{C}$  produces a heat transfer rate of  $\sim 90$  kWt at the  $500^\circ\text{C}$  melting point of NaCl, CaCl<sub>2</sub> eutectic and a transfer rate of  $\sim 140$  kWt at the  $638^\circ\text{C}$  melting point of NaCl, Na<sub>2</sub>CO<sub>3</sub> eutectic.

TABLE E-1  
Energy Delivery Rates for  
2MWht Radiation Coupled Energy Storage Tank

Temperature °C	Heat into Salt (kWt)		Heat out of Salt (kWt)	
	$\Delta T = 20^\circ\text{C}$	$\Delta T = 40^\circ\text{C}$	$\Delta T = 20^\circ\text{C}$	$\Delta T = 40^\circ\text{C}$
300	18.5	39.6	16.9	32.1
350	24.1	50.5	21.8	41.6
400	30.2	63.2	27.6	52.9
450	37.4	77.8	34.4	65.9
500	45.5	94.6	42.1	81.0
550	54.8	114	51.0	98.3
600	65.3	135	61.0	118
650	77.0	159	72.2	140
700	90.1	186	84.7	164
750	104.5	215	98.6	191
800	120.5	248	114	222
850	138	283	131	255

$\Delta T$  = temperature difference between heat pipe surface and salt can surface

We next discuss the role of gas convection and conduction in the operation of a radiation coupled energy storage tank. We show that convective and conductive transport are negligible compared with radiative energy transport for the design shown.

Convective transport can be calculated in accordance with the vertical enclosed cell studies of Landis and Yanowitz<sup>(1)</sup> as given in Perry and Chilton<sup>(2)</sup>.

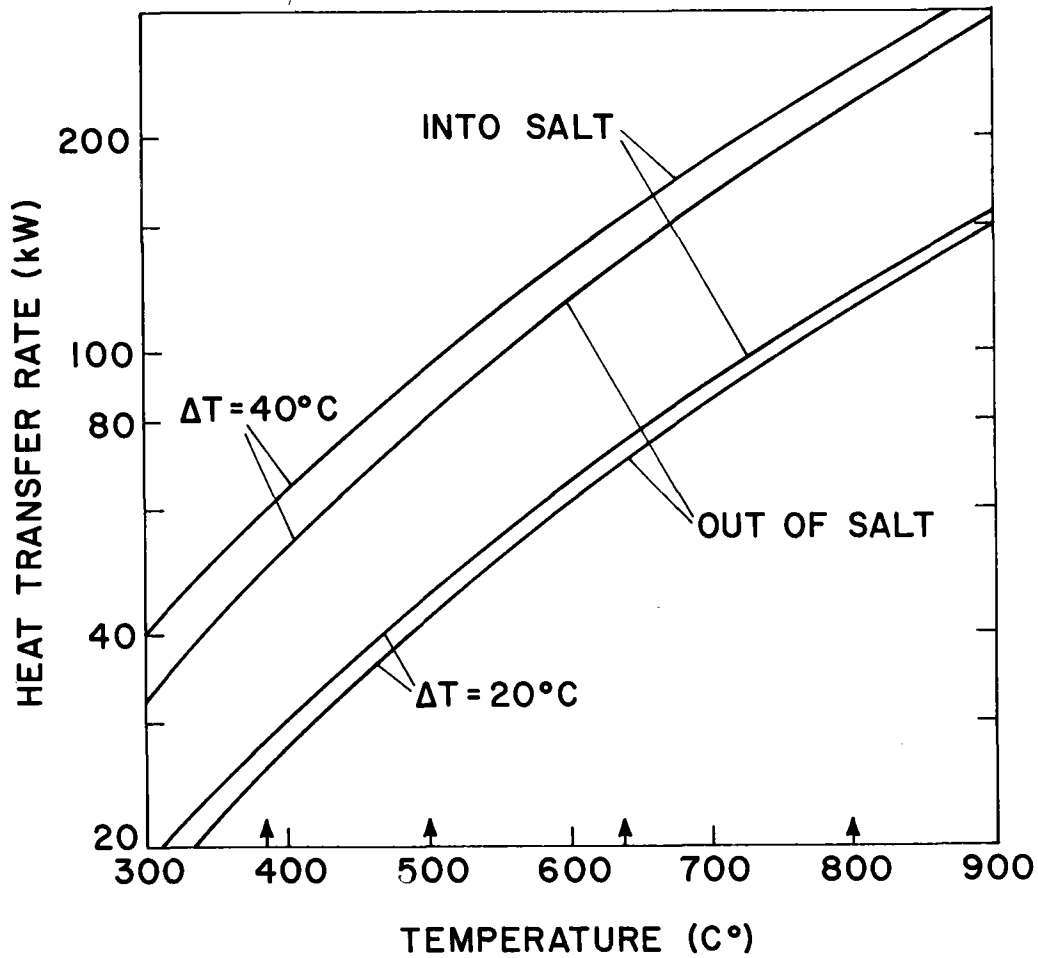

Fig. E-2 — Heat transfer-rate into and out of salt cans as a function of energy storage temperature. Heat transfer rate into the salt means energy input rate for tank shown in Fig. E-1. Input and output rates are shown for two values of input and output temperature drop as measured between surface of the potassium heat pipes and surface of the salt cans. The product of emissivity  $\times$  effective absorptivity has been assumed to be 0.81.



$$\begin{aligned}\frac{h\delta}{k} &= .123 \cdot N_{Pr}^{.28} g^{.28} \left( \frac{\delta^3 \rho^2}{\mu^2} \frac{\Delta T}{T} \right)^{.28} \\ &\cong 0.762 \left( \frac{\delta^3 \rho^2}{\mu^2} \frac{\Delta T}{T} \right)^{.28}\end{aligned}$$

In cgs units,  $\delta$  is the separation between hot and cold walls in cm,  $\rho$  is the gas density in  $\text{g cm}^{-3}$ ,  $\mu$  is the viscosity in poise,  $\Delta T$  is the difference in temperature between hot and cold walls,  $T$  is the absolute temperature,  $N_{Pr}$  is the Prandl number, and  $g$  is the acceleration of gravity. For  $N_2$  at  $500^\circ\text{C}$ ,  $\Delta T = 20^\circ\text{C}$  and  $\delta = 5.08$  cm we find

$$h = .000031 \text{ cal cm}^{-2} \text{ s}^{-1} \text{ K}^{-1}.$$

With the whole tank filled with air, convective heat transfer at  $20^\circ\text{C}$  amounts to only

$$Q_{\text{conv}} = 0.67 \text{ kWt.}$$

One can use helium gas within the containment vessel to increase heat transfer. With helium, the separation between hot and cold surfaces is inadequate to fully develop convective transport in accord with the Landis-Yanowitz equation. Pure conduction through the helium then plays a larger role. For  $\Delta T = 20^\circ\text{C}$ , and with a slow gas motion due to convection, about 1/6 of the temperature drop occurs at each of the two solid-gas interfaces, and about 2/3 occurs due to the conductive drop across the gas. At the solid-gas interface, the Nusselt number  $\frac{(h\delta)}{(k)}$  has the value 3.656. For conduction through the gas,  $h = k/\delta$ . Total energy transport by conduction for the tank shown in Fig. E-1 is

$$Q_{\text{cond}} = 2.0 \text{ kWt.}$$

Open cell structures with helium gas have also been examined. Gas circulation velocities and gas heat capacity are too small to transport significant heat with  $\Delta T = 20^\circ\text{C}$  by open cell circulation.

All of the above gas heat transport rates are less than 5% of the energy transport rate provided by radiation alone at 500°C,  $\Delta T = 20^\circ\text{C}$ , as shown in Table E-1. Radiation alone provides more than adequate energy transport for an energy storage tank designed in accordance with Fig. E-1, provided that an energy input time of 44 hours at a 20°C temperature drop is acceptable. An increase in the diameter of the heat pipe radiating surface to 4" would reduce energy input and withdrawal times to 22 hours. Further, a doubling of the energy input and withdrawal  $\Delta T$  to 40°C would reduce the time required for energy input and withdrawal to about 11 hours, comparable to the loading time of the energy storage boiler tank.

#### REFERENCES

- E1. Landis and Yanowitz, *Proc. 3d Intern. Heat Transfer Cont.*, Chicago, 1966, Vol. II, p. 139.
- E2. Perry, R.H. and Chilton, C.H., *Chemical Engineers' Handbook, 5th Edition*, (McGraw-Hill, New York, 1973) pp. 10-11, 10-12.
- E3. Rosenow, W.M. and Harnett, J.P., *Handbook of Heat Transfer*, (McGraw-Hill, New York, 1973) p. 7-20.

## Appendix F

### HEAT TRANSFER FLUID TECHNOLOGY, COSTS, AND TOXICITY FOR 385°C USE

The 2 MWht storage tank makes use of m-terphenyl as the heat transfer fluid. The tank will be loaded with 1.75 tons of heat transfer fluid. It contains 30 tons of salt. Thus, the mass ratio of heat transfer fluid to salt is .058. Heat transfer fluid usage is about 0.96 tons of heat transfer fluid per MWht of energy storage.

M-terphenyl is the major component of Therminol 88 and occurs in ~50% abundance. Since the storage tanks operate as fractionating columns, it is possible to use the tanks to fractionate the Therminol 88 terphenyl mixture during start-up. Operating in this manner, the heat transfer fluid requirement would be 1.90 tons of Therminol 88 per MWht storage capacity.

The 2 MWht tank makes use of specially fractionated m-terphenyl, which was purchased from Monsanto Research Laboratory (1515 Nicholas Rd., Dayton, OH 45418) for \$12.00 lb<sup>-1</sup>, corresponding to \$23.04 kWht<sup>-1</sup> without replacement. If the m-terphenyl were purchased as Therminol 88 from Monsanto Chemical Co. at current prices, the cost would be \$1.94 lb<sup>-1</sup>. Purified m-terphenyl would cost about \$3.00 per pound. Current prices for Therminol 88 are \$1940 ton<sup>-1</sup>, corresponding to \$3880 ton<sup>-1</sup> for the included m-terphenyl. This cost amounts to \$3.70 kWht<sup>-1</sup> for start-up.

There is as yet no consensus on the pyrolytic stability of the terphenyls as shown in the data summarized by Boyd<sup>(1)</sup>. Values measured by de Halas<sup>(2)</sup> for m-terphenyl and by Pinero and Rodriques<sup>(3)</sup> for the mixed terphenyl Gilotherm OM2 are shown in Fig. F-1. Gilotherm

OM2 is 77% m-terphenyl, ~23% o-terphenyl, however de Halas shows little difference between m-terphenyl and p-terphenyl pyrolyzation rates. Extrapolation of the Pinero, Rodriquez data set to 400°C gives decomposition rates of .45% per day, to 385°C gives a decomposition rate of .17% per day, to 370°C gives a decomposition rate of .068% per day. Extrapolation of the de Halas data gives decomposition rates of .031% per day at 400°C, .011% per day at 385°C and .0028% per day at 370°C.\*

In operation, we can expect that the heat transfer fluid in the energy storage boiler tank will operate at 395°C for 25% of the time, at ~380°C for 75% of the time. Under these conditions, the 395°C operating periods will provide 45% of the total degradation. The effective operating temperature will be 386°C. Based on the Piniro-Rodriguez data degradation should proceed at a rate of .127% per day, corresponding to a life of 1.6 years. Based on the de Halas data, degradation should proceed at a rate of .011% per day, corresponding to a life of 25 years.

Rhone-Poulenc state that terphenyls are not considered toxic. Dr. Melvin Calvin, 1961 Nobel prize winner in chemistry and world authority on chemical carcinogenesis at a recent lecture stated that biphenyl, which is closely related to terphenyl, is not considered carcinogenic, in contrast to large flat aromatics such as benzo-pyrene and the small flat aromatic benzene. (Benzene was stated to be only mildly carcinogenic.) The reason that benzo-pyrene is a strong carcinogen is that reactive metabolates of benzo-pyrene are much more reactive to DNA components than to protein components. This specificity in reactivity is the property which causes DNA damage, the first step in induction of cancer. Biphenyl, at low concentration, apparently either has different types of metabolates, or because of its freedom to rotate about the ring-to-ring bond, does not share with benzo-pyrene a preferred affinity to DNA. The point made by

\*Recent testing by V. Burrola of Sandia Labs, Livermore, CA, supports the longer material lifetime as measured by de Halas.

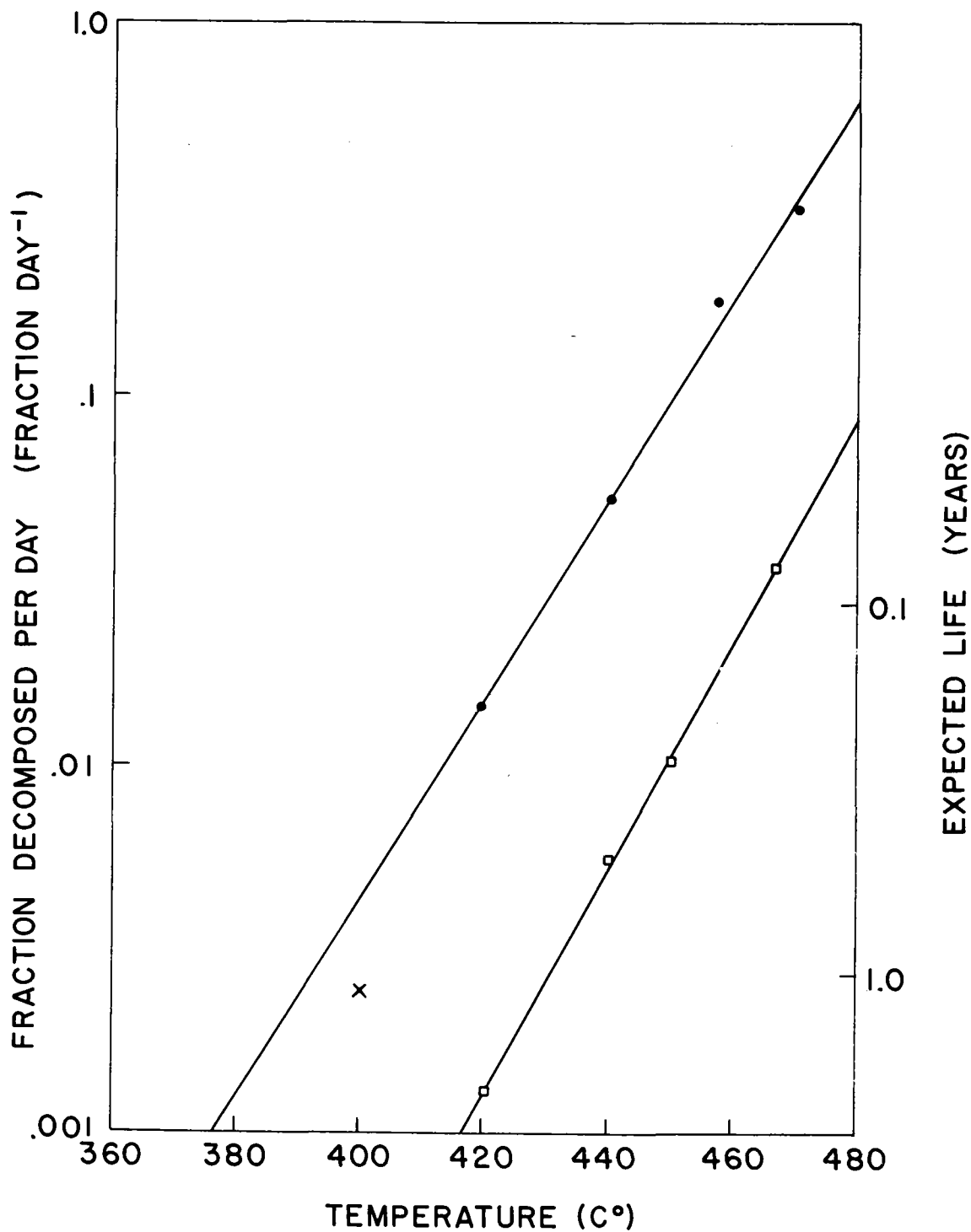

Fig. F-1 — Terphenyl decomposition rate vs. temperature. Data marked by dots is based on measurements by Pinero and Rodriguez<sup>(9)</sup> on mixed terphenyl Gilotherm OM2. The cross is an approximate decomposition rate at 400°C provided by Rhône-Poulenc Industries. Squares are data obtained by de Halas<sup>(2)</sup> for m-terphenyl. Decomposition is accompanied by a build-up of higher-polyphenyls<sup>(2)</sup>, limiting the life of the terphenyl transport fluid.

Dr. Calvin is that, in discussing aromatics, it is important to distinguish between the flat carcinogenic aromatics of the benzo-pyrene type and the relatively non-toxic biphenyl type materials.

#### REFERENCES

- F1. A.W. Boyd, "The Radiolysis and Pyrolysis of Organic Coolouts," *J. Nuc. Mat.* 9, 1 (1963).
- F2. D.R. de Halas, Hanford (USA) Report HW-56769 (1958).
- F3. R. Barrera Pinero and M. Rodriguez, "Comportamiento pirolitico de las mezclas terfenilicas comerciales," *J.E.N.* 123 DQ/137. (Junta de Energia Nuclear, Ciudad Universitaria, Madrid, Spain)
- F2. Rhone-Poulenc, "Fluides Organiques de Transfert Thermique a haute temperature, resistant aux rayonnements," Technical Bulletin, Notice Provisoire, (Rhone-Poulenc S.A., 22, queneve Montaigne, 75008, Paris).

CHUBB, NEMECEK, AND SIMMONS

# Monsanto

SPECIALTY CHEMICALS DIVISION

**MONSANTO INDUSTRIAL CHEMICALS CO.**  
800 N. Lindbergh Boulevard  
St. Louis, Missouri 63166  
Phone: (314) 694-1000

October 5, 1979

Dr. Talbot Chubb  
Naval Research Laboratory  
Code 7120  
Washington, D.C. 20375

Dear Dr. Chubb:

Confirming our telephone conversation of October 4th, the current price of Therminol<sup>®</sup> 88, mixed terphenyls, is 97¢ per lb. FOB Anniston, Alabama.

We understand that your interest is in the separation of meta terphenyl from the mixture to be used in a 2MW/hr solar storage system. The cost of the meta derivative can not be extrapolated directly from the content in the mixture; the separation economics will depend on the availability of markets for the separated O and P isomers. If these are not available the raw material values and conversion costs of the unwanted fractions would have to be applied to the meta fractions. Purely as an estimate, the cost of meta terphenyl at a volume of 2-3 million pounds per year could be \$3.00-\$4.00 per lb. We would need to explore these costs in more detail as your project with DOE proceeds.

I will review our conversation with Dr. E. K. Brakebill, here, at Monsanto. Dr. Brakebill is managing our development programs for heat transfer in solar energy. I am sure that he will wish to contact you to discuss the Solchem project.

Sincerely yours,

D. Wood  
Market Manager  
Heat Transfer and Process

DW:pb

cc: Q. E. Thompson  
R. L. Green  
E. K. Brakebill  
E. T. Mollica

a unit of Monsanto Company

## Appendix G

### CONTAINER TECHNOLOGY AND COSTS

The salt container is an important component in the latent heat-of-fusion energy storage units being developed at NRL. The large aggregate surface area of the containers makes possible energy input and output at a satisfactorily small  $\Delta T$ . The containers are an important cost element, although for at least the early generation tanks the container costs will be significantly less than the cost of the salt contained therein.

The salt containers must have the property of being compatible with both the molten salt and the heat transfer fluid. For the material set under study; namely,  $MgCl_2$ , NaCl, KCl, and m-terphenyl, mild steel is an appropriate container material. It is only necessary that the salts contained be thoroughly dried before loading into the containers and that they be protected from atmospheric moisture during warehousing prior to installation into the energy storage assembly. Rusting of the external surfaces of the containers prior to installation is a potential problem area.

The 2 MWht tank under construction uses cans 19" high made of 30 gauge (.012") mild steel terneplate. The cans have continuous seam spot welds which are used both to convert sheet into cylinders and to seal bottom and top closures to the metal cylinders. The bottom closure is a stamped cup. The top closure is a stamped closure fitted with a screw-on lid of the type used in the food industry. The cans are made on production line machinery using the Soudronic machine for production forming and continuous wire welding of the cylinders. Top and bottom closures were attached using a radial spot weld machine. The cans are designed to



CHUBB, NEMECEK, AND SIMMONS

operate with equal pressures inside and outside the cans, and the lids are fitted with a breathing hole which is sealed during preinstallation storage, but which opens at operating temperature.

Our present can supplier is the Ellisco Company, American and Luzerne Streets, Philadelphia, PA 19140. The 4000 cans for the 2 MWht tank are costing \$4.28 per can. Prices for larger scale production ( $3.0 \times 10^6$  cans per year, guaranteed for 20 years) are estimated to be \$1.21 per can. This is not a large run and would be produced at the existing Philadelphia plant. The  $3.0 \times 10^6$  cans per year would containerize 20,000 tons of salt per year (1300 MWht or 440 MWhe storage capacity per year).

For larger scale production, can costs can be expected to approximate the costs of food cans. Tall #3 cans ( $4\frac{1}{4}$ " diameter, 7" tall) manufactured by Freund Can Company (200 West 84th Street, Chicago, Il 60620) were priced in 1975 at \$.29 in \$1000 orders. This cost comes to .041 \$ per linear foot, corresponding to \$.78 for a 19" can. Inflating at 10% per year leads to a cost of \$1.15 per can. Assuming larger orders can reduce costs an additional 15%, leads to a cost estimate of \$1.00 per can.

## **Appendix H**

### **LABORATORY STUDIES ON ENERGY INPUT, HEAT TRANSFER, AND MATERIALS COMPATIBILITY FOR A 385°C ENERGY STORAGE BOILER TANK**

The 2 MWht proof-of-concept energy storage boiler tank was designed subsequent to a series of laboratory studies which were carried out to examine the mutual compatibility of the required material set. The laboratory studies also served to check salt melting-freezing characteristics, terphenyl degradation, heat transfer fluid fractionation, and to provide an experience base needed for successful subsequent system scale-up. These laboratory studies are highlighted in the two reports which follow.

2 Megawatt Hour Energy Storage-Boiler Tank

J.J. Nemecek, T.A. Chubb, and D.E. Simmons  
 Naval Research Laboratory  
 Washington, D.C. 20375

28 August 1978

ABSTRACT

Site planning for construction of an energy storage tank containing 30 t of NaCl, KCl, MgCl<sub>2</sub> salt eutectic is largely complete. Energy input is provided by 150 kW electrical heaters. Energy output is provided by a steam boiler-superheater believed capable of removing stored energy at rates up to 500 kW. Heat transfer within the storage tank is effected by evaporation/condensation of m-terphenyl. Results of development tests and construction plans are presented.

1. INTRODUCTION

Massive energy storage involves utilization of major tonnages of storage material. In [1] Nemecek et al. describe an energy-storage boiler tank in which heat is effectively transferred to and from large quantities of fusible salt by condensation and evaporation of heat transfer fluid. Temperature drops within the salt are minimized by making available large areas for heat conduction by encapsulating the salt in containers with a large aggregate surface area. In [2] Chubb et al. describe the coupling of the energy storage medium to a steam generator which functions as a condensation boiler. In this paper we describe laboratory studies carried out in support of plans to construct a 7.2 GJ (2 MWh) storage tank using these principles, and the design status of the 2 MWh tank.

2. LABORATORY STUDIES

Heat transfer studies have been carried out in a small insulated laboratory tank (.33 m ID, .41 m high) in which heat is applied to the tank by placing the tank on a 2 kW range element. The tank in its present configuration is shown in Figure 1. Insulation is provided by loose vermiculite which surrounds the sides and top of the tank to a thickness of 0.3 m during heat runs. The tank is used to study heat transfer from a pool of terphenyl fluid which covers the bottom of the tank to cans of salt which are stacked in the body of the tank. The assembly is instrumented with thermocouples that measure the temperature of the terphenyl liquid, the terphenyl vapor (near bottom, middle and top of tank), the salt in one can, and outside tank wall temperatures. Tank pressure and power input are also recorded.

The first series of runs were made using NaCl, KCl, MgCl<sub>2</sub> eutectic (MP 385°C) poured into 50 mm × 100 mm × 100 mm open steel cans. Before pouring, the salt was thoroughly dried by etch attack by the molten salt on aluminum metal shavings. Air was removed from the tank prior to initiation of heat runs. These runs taught the following:

1) Use of mixed terphenyls, e.g. Therminol 88, resulted in nonuniform temperatures in the tank due to fractionation. Under isobaric conditions o-terphenyl, which accumulates at the top of the tank, condenses at about 33°C lower temperature than m-terphenyl,

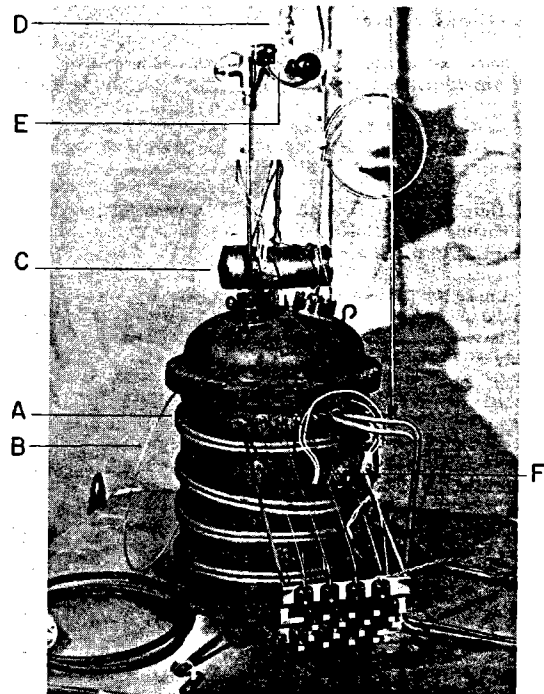

Fig. 1. A, Laboratory test tank; B, metal O-Ring used to seal domed lid to tank body; C, buffer tank; D, heated vent line; E, heated vent valve; F, thermocouples.

which in turn condenses at about 17°C lower temperature than p-terphenyl.

2) On an initial heat run, new terphenyl heat transfer fluid should be carefully heated to drive off, by venting into a hood, any high vapor pressure contaminants that may be in the batch. Heated vent lines need to be used.

3) With relatively pure m-terphenyl (o-terphenyl 0.6%, p-terphenyl 8%) good temperature uniformity can be achieved if small quantities of higher vapor pressure materials are vented from the top of the tank.

4) Mounting a buffer tank above the main tank in such a manner that condensed liquid is returned to the main tank while high vapor pressure gases are accumulated in the buffer tank reduces the vent-

## NRL MEMORANDUM REPORT 4267

ing requirement for good temperature uniformity, so that only a few grams of heat-transfer fluid need be removed by venting during an energy input run.

- 5) Heat transfer from m-terphenyl liquid in the bottom of the tank into the melting salt interface can be achieved at acceptable heat transfer rates with a temperature drop never exceeding 12°C.
- 6) Salt that melts and freezes in open contact with terphenyl vapor develops a porous crust that thickens with cycling and which could lead to salt overflowing the tops of the open cans if a large number of melt cycles were employed.
- 7) No serious corrosion problems occurred.

A second series of energy storage runs were made using purchased containerized salt. The salt was contained in 1 quart paint cans which have a 100 mm diameter. The salts were melt cycled 18 times. These heat runs taught the following lessons:

- 1) Some, but not most, of the paint cans leaked molten salt. (The salt cans depend on crimping of steel plus soft solder for sealing.)
- 2) All cans, except one, were not hermetically sealed by the lids. The one can that sealed itself off imploded or crumpled during one of the cool down periods. The can leaked and lost all its salt.
- 3) Despite continual maintenance of m-terphenyl-salt contact, crusting did not build up to the point where the top surface of the salt reached the paint can lids.
- 4) Unlike salt that solidified in dry nitrogen, the 18-times cycled salt did not freeze into a monolithic wall surrounding a single cavity; instead, the sectioned salt showed a rather porous, multiple cavity internal structure.

A single heat run was made using a single large salt container 0.3 m OD and 0.2 m high. The container was made of steel. It contained an internal aluminum tube-like structure equivalent to six 0.1 m OD tubes spring loaded so as to maintain aluminum-steel contact after melt. The aluminum conductivity-enhancement structure used metal 1.5 mm thick. The salt container was filled by pouring molten salt into the container. Unfortunately the salt fill was not properly premixed, and full melting was not subsequently achieved. During the heat run salt in the tank was not permitted to come into contact with terphenyl vapor. Lessons learned from this study were:

- 1) In the cold container salt shrinkage resulted in separation of the salt block with its embedded aluminum conduction enhancers from the steel container wall. Good thermal contact was not established until partial melting of the salt block occurred at 385°C.
- 2) Once partial melting occurred the temperature drop between steel wall and salt mid-interior was about 15°C, i.e. the aluminum conductivity enhancers worked as expected.

A measurement of the heat of fusion of the NaCl, KCl, MgCl<sub>2</sub> eutectic was carried out under the direction of S.C. Spiney of Dynatech Corporation using a drop calorimeter [3]. His value was 240 kJ kg<sup>-1</sup>. This value is less than that previously incorrectly measured by us. Parameters for a 3 m energy storage tank as listed in [1] require adjustment. New values are: Energy Stored, 7.2 GJ (2 MWh), Salt Mass, 30 tonnes, salt volume, 16.7 m<sup>3</sup> (based on liquid density of 1.8 gm cm<sup>-3</sup>). These parameters apply to the 2 MWh demonstration tank described below.

### 3. PLANS FOR 2 MWh TANK

The 2 MWh tank is being constructed at NRL at the site of an old ammunition bunker which provides a concrete foundation — 6.0 m square. The tank will be installed on a foam glass foundation 0.6 m thick. The tank itself is planned as a flat bottomed steel structure with a 50 mm thick steel plate bottom, and 10.0 mm thick cylinder walls. It is 3.0 m inside diameter and 3.6 m high. The top of the tank is flanged to receive a metal O-ring gasket 3.2 m in diameter and 6.0 mm diameter in cross section. A domed head with mating flange will act as the cover of the tank. The domed head is designed to contain the condensation boiler. The tank will be made of carbon steel, the head will use 316L stainless steel, the boiler, designed in accordance with reference [2], uses tubing made of 316L stainless. Vermiculite insulation will be used around the sides and top of the tank.

The tank will be heated by 150 kW electric immersion heaters. Present plans are to use tubular elements cast in aluminum heat conduction blocks for uniform distribution of the heating power. The heater will be placed inside the tank with power brought into the tank by MgO packed power feed-throughs or some other hermetic fitting. Terphenyl fluid circulation, as used during the energy removal portion of storage cycle, will be provided by a 4000 l.hr<sup>-1</sup> hot fluid circulation pump located in a small access chamber adjacent to the bottom of the tank. The heat transfer fluid will form a pool of liquid 0.3 m thick covering the bottom of the tank. The storage medium will be supported by a steel grid resting on the metal heater billets. These heater units sit on the flat bottom of the tank and are immersed in the heat transfer fluid. The salt itself will be contained in thin wall steel cans of 105 mm diameter and as-yet-unspecified height. The cans will use spot seam welding as the bottom and side can seals. The can lids will be conventional roll-over crimped lids. A hole will be punched in the can lids prior to can installation to permit breathing during melt cycling. The hermetic sealing property provided by the lids is used only during material storage, where it is used to prevent salt hydration.

The energy storage tank siting is being carried out in such a manner that the tank can be serviced using a lightweight traveling gantry crane, which can lift the lid of the tank and can aid in loading and unloading the salts. It is planned so that the gantry will be able to service two tanks, in that it is hoped to construct a higher temperature superheater storage tank in the same vicinity. The storage tank will be protected from the weather by a light weight roof, which is also removable. The insulating vermiculite is also removable, being transported to a grain bin by a vacuum piping arrangement.

Plans are to initiate tank operation without salts. The initial studies will outgas the heat transfer fluid, test the electrical heating and fluid circulation systems, evaluate vapor temperature distribution and test the operation of the condensation boiler and associated feed-water pumps. 30 t of salt eutectic will then be installed and the storage operation evaluated.

### 4. REFERENCES

- [1] J.J. Nemecek, D.E. Simmons and T.A. Chubb, "Demand sensitive energy storage in molten salts", *Solar Energy* 20, 213 (1978).
- [2] T.A. Chubb, J.J. Nemecek and D.E. Simmons, "Energy storage-boiler tank: boiler design, materials compatibility tests", Proceedings of the 1977 Annual Meeting American Section of the International Solar Energy Society, 18-10 (1977).

## ENERGY STORAGE BOILER TANK, PROGRESS REPORT

*T. A. Chubb, J. J. Nemecek and D. E. Simmons*

Naval Research Laboratory

Washington, D.C. 20375

29 September 1977

### ABSTRACT

The energy storage boiler tank stores energy in molten salt eutectic and uses evaporation/condensation of a heat fluid for energy transport within the tank. In laboratory tests 54 lbs of NaCl, KCl, MgCl<sub>2</sub> eutectic has been melted by terphenyl condensation with a  $\Delta T$  of less than 12°C between the pool of liquid terphenyl in bottom of tank and salt meltpoint.

The Energy Storage Boiler Tank<sup>(1)</sup> (ESBT) is a means for providing energy storage at moderately high temperature. The goal is to provide storage of large quantities of energy at low cost and in a form suitable for generation of on-demand superheated steam. One application is to provide energy storage for municipal utilities, especially utilities energized by sunlight<sup>(2)</sup>, where storage is needed to permit full power production during night time periods, cloudy days and peak power intervals.

NRL is currently working on a first version of the ESBT, Figure 1. This version used fusion of a salt eutectic mix (NaCl, KCl, MgCl<sub>2</sub>) as a means of energy storage. The salt mix melts at a temperature of 385°C. Energy flow into and out of the salts is achieved by heat pipe techniques, using the evaporation and condensation of a terphenyl heat transfer fluid. By packaging the salt in containers with a large aggregate surface area, the ESBT compensates for the poor thermal conductivity of the salts, achieving acceptable temperature drops ( $\Delta T$ ) associated

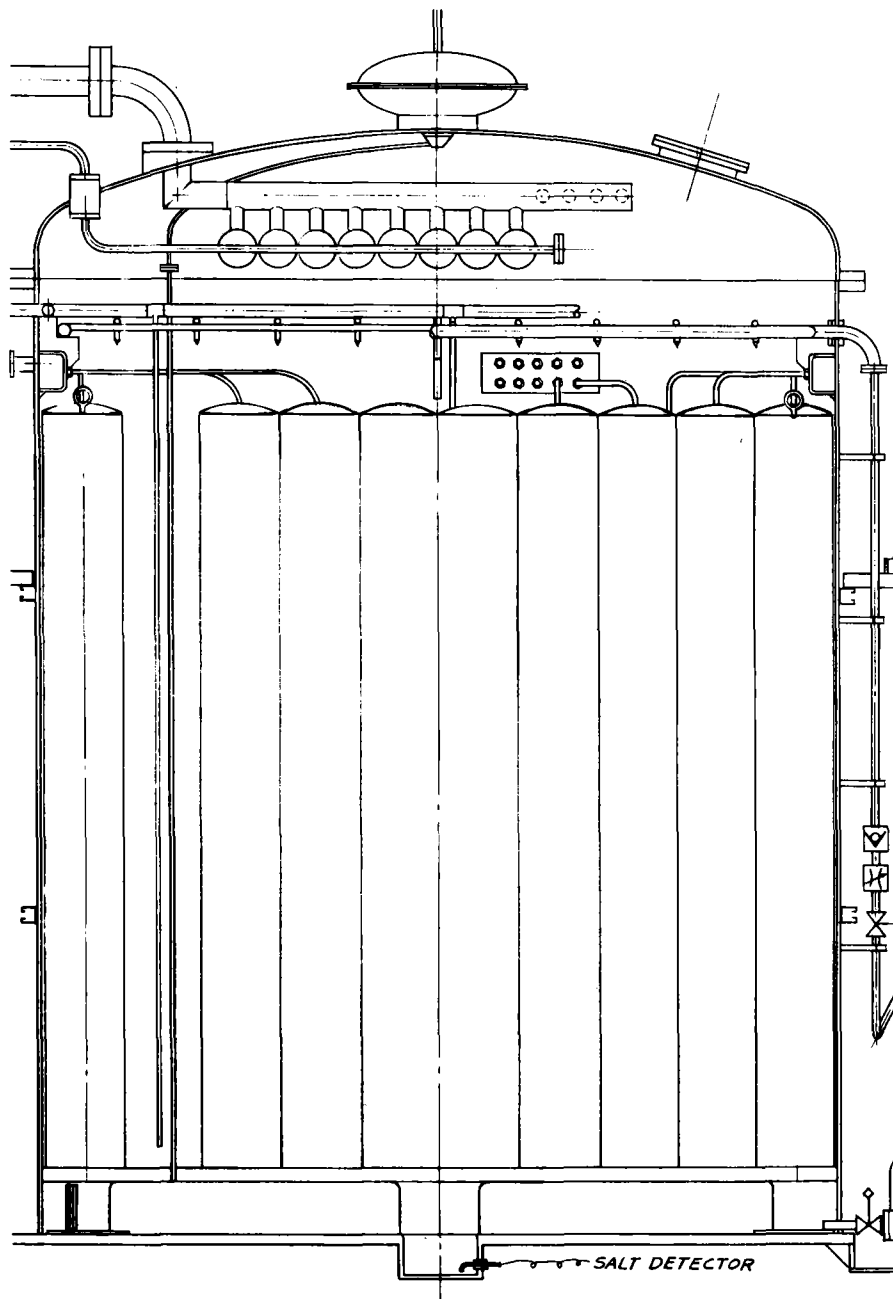

Figure 1. Drawing of 10-foot energy storage tank. The tank is designed to receive 150 kw of electrical heat and to store 2 MWh of thermal energy. The design option illustrated uses 10-foot long, 12" diameter salt containers with interior aluminum members for conductivity enhancement. The salt containers are separately manifolded to an inert atmosphere, so as to avoid contact between molten salt and heat transfer fluid. Such separation may not be necessary. Drawing shows spray ports used to keep containers wetted with heat transfer fluid during the energy withdrawal period. Also shown is a condensation steam boiler and superheater assembly inside the domed tank lid.

with energy input and withdrawal. The ESBT also uses a condensation boiler heated by the same terphenyl heat pipe fluid. As a result it serves as a demand responsive source of high temperature steam.

The ESBT program is still in the laboratory stage with work directed toward construction of a pilot 2 MWh (thermal) storage tank and steam generator about a year or so from now. Laboratory tests are carried out in a 14" diameter tank containing 54 lbs of packaged salt eutectic. We are currently studying the energy input process and melt cycling problems using condensation of terphenyl heat transfer fluid as the means of distributing heat and melting the salts. Late in the spring we passed the first important milestone in the development, namely that of melting the salt eutectic by terphenyl condensation.

Terphenyl in its most readily available form is bought as Therminol 88 from Monsanto. Therminol 88 is a mixture of 3 terphenyls, each with a different boiling point. Our studies indicate that it is desirable to remove the lowest boiling component from the mix prior to its use in the ESBT. Recently, we have operated our lab ESBT using a largely m-terphenyl fraction obtained from Eastman with an approximate composition: 8% p-terphenyl, 91% m-terphenyl, 0.6% o-terphenyl. With this material we have succeeded in melting our 54 lbs of salt under conditions such that the temperature of the liquid terphenyl at the bottom of the tank never exceeded the melting point of the salt by more than a  $\Delta T$  of 12°C (Figure 2). We expect a similar  $\Delta T$  at energy withdrawal in a fully developed ESBT, in which case the total  $\Delta T$  cost of energy storage will be about 25°C.

An attractive feature of the ESBT is the condensation boiler which is included inside the tank. The boiler for the 2 MWh tank has been initially designed and analyzed.<sup>(3)</sup> As designed the boiler will be able to provide energy withdrawal at a 0.5 MW rate, at a steam temperature of

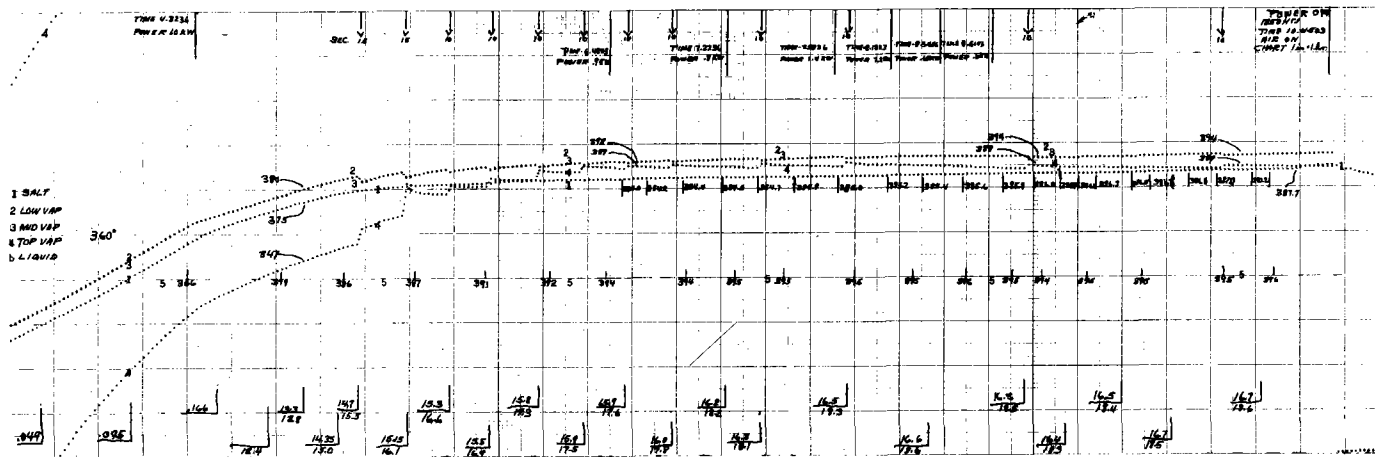

Figure 2. Energy input run demonstrating melting of 54 pounds of salt eutectic by terphenyl condensation. Trace 1 shown salt temperature vs. time. Traces 2, 3, and 4 measure vapor temperatures near the bottom, middle, and top of the tank. During the melt process the temperature of liquid m-terphenyl at the bottom of the tank differed only slightly from that of the vapor and never exceeded the melting point of the salt by more than 12°C.



340°C and a steam pressure of 800 psia. At lower withdrawal rates, steam temperatures should approach the 385°C of the molten storage salt.

There are still a number of important questions to be answered and decisions to be made. How low should the o-terphenyl content of the heat transfer fluid be kept? Can the tank be designed to provide continuous removal by fractionation of o-terphenyl and possible low boiling dissociation fractions? Can the tank be designed to provide continual vapor circulation, so as to reduce stratification of vapors of varying p-terphenyl/m-terphenyl ratio? How low should the p-terphenyl and quatraphenyl content be kept? Most importantly, how stringently should the salt be separated from the heat transfer vapor? Present tests have been carried out with open salt cans. Crusting of the salt surface is observed. Nonetheless we have melt cycled the salt several times without apparent difficulty.

We will shortly make decisions on several of the above questions as regards the 2 MWh ESBT. Experience with the 2 MWh tank will then determine the wisdom of our decisions or the need to back-track and redesign portions of the unit.

#### ACKNOWLEDGMENT

This program is jointly supported by DoD and ERDA.

#### REFERENCES

1. Nemecek, J.J., D.E. Simmons and T.A. Chubb, "Demand Sensitive Energy Storage in Molten Salts," *Solar Energy* 19, , 1977.
2. Chubb, T.A., "A Chemical Approach to Solar Energy," *CHEMTECH* 6, 654, 1976.

NRL MEMORANDUM REPORT 4267

3. Chubb, T.A., J.J. Nemecek and D.E. Simmons, "Energy Storage-boiler Tank: Boiler Design, Materials Compatibility Tests," Proceedings of the ISES Meeting, Orlando, FL, 18-10, 1977.

DEPARTMENT OF THE NAVY

---

NAVAL RESEARCH LABORATORY  
Washington, D.C. 20375

---

**OFFICIAL BUSINESS**

PENALTY FOR PRIVATE USE, \$300

POSTAGE AND FEES PAID  
DEPARTMENT OF THE NAVY  
DoD-316

THIRD CLASS MAIL



THE NAVAL RESEARCH LABORATORY IS AN  
ACTIVITY OF THE OFFICE OF NAVAL RESEARCH