

5105-144

Solar Thermal Power Systems Project  
Parabolic Dish System Development

DOE/JPL-1060-80

Distribution Category UC-62

*Camera  
Dist*

# Development of an Organic Rankine-Cycle Power Module for a Small Community Solar Thermal Power Experiment

T. Kiceniuk



January 15, 1985

Prepared for  
U.S. Department of Energy  
Through an Agreement with  
National Aeronautics and Space Administration  
by  
Jet Propulsion Laboratory  
California Institute of Technology  
Pasadena, California

JPL Publication 85-3

5105-144  
Solar Thermal Power Systems Project  
Parabolic Dish System Development

DOE/JPL-1060-80  
Distribution Category UC-62

# Development of an Organic Rankine-Cycle Power Module for a Small Community Solar Thermal Power Experiment

T. Kiceniuk

January 15, 1985

Prepared for  
**U.S. Department of Energy**  
Through an Agreement with  
**National Aeronautics and Space Administration**  
by  
**Jet Propulsion Laboratory**  
California Institute of Technology  
Pasadena, California

JPL Publication 85-3

Prepared by the Jet Propulsion Laboratory, California Institute of Technology, for the U.S. Department of Energy through an agreement with the National Aeronautics and Space Administration.

The JPL Solar Thermal Power Systems Project is sponsored by the U.S. Department of Energy and is part of the Solar Thermal Program to develop low-cost solar thermal and electric power plants.

This report was prepared as an account of work sponsored by an agency of the United States Government. Neither the United States Government nor any agency thereof, nor any of their employees, makes any warranty, express or implied, or assumes any legal liability or responsibility for the accuracy, completeness, or usefulness of any information, apparatus, product, or process disclosed, or represents that its use would not infringe privately owned rights.

Reference herein to any specific commercial product, process, or service by trade name, trademark, manufacturer, or otherwise, does not necessarily constitute or imply its endorsement, recommendation, or favoring by the United States Government or any agency thereof. The views and opinions of authors expressed herein do not necessarily state or reflect those of the United States Government or any agency thereof.

Work conducted through NASA Task RE-152, Amendment 327, and sponsored by the U.S. Department of Energy under Interagency Agreement DE-AM04-80AL13137.

## ABSTRACT

An organic Rankine-cycle (ORC) power module was designed and developed for use in a multi-module solar power plant to be built and operated in a small community. Although neither final design nor construction of the multi-module plant took place, many successful components and subsystems, including the receiver, power conversion subsystem, energy transport subsystem, and control subsystem, were developed and tested before the program was halted. In addition, tests were performed on a complete power module using a test bed concentrator in place of the proposed concentrator at the Jet Propulsion Laboratory's Parabolic Dish Test Site at Edwards Air Force Base, California. Test results with the complete module verified that all major single-module program functional objectives were met and that multi-module operation presented no apparent problems. The hermetically sealed, self-contained, ORC power conversion unit subsequently successfully completed a 300-hour endurance run with no evidence of wear or operating problems.

## ACKNOWLEDGMENT

The work reported in this overview represents the efforts of many talented and dedicated individuals at the U.S. Department of Energy, Jet Propulsion Laboratory, Ford Aerospace and Communications Corporation, Barber-Nichols Engineering Company, Simmonds Precision, and Nova Electric. Although the intended multi-module plant envisioned under this program never materialized, the equipment and information they produced should prove valuable in the search for an effective way to produce electricity using the sun's energy.

## GLOSSARY

### ABBREVIATIONS AND ACRONYMS

AFB	Air Force Base
ATC	Aerothermochemical Laboratory (FACC Facility)
B-N	Barber-Nichols Engineering Company
CCIA	Central Control Interface Assembly (interfaces MPC to RCIA's)
C&I	Control and Instrumentation
CRT	Cathode Ray Tube
DOE	U.S. Department of Energy
DSM	Drafting Standards Manual (FACC)
EAFB	Edwards Air Force Base, California
ETS	Energy Transport Subsystem
EPROM	Erasable, Programmable Read-Only Memory
EU	Engineering Units
FACC	Ford Aerospace and Communications Corporation
GE	General Electric Company
JPL	Jet Propulsion Laboratory
LeRC	Lewis Research Center (NASA)
MOP	Master Operational Program
MPC	Master Power Controller (central computer)
NASA	National Aeronautics and Space Administration
NBO	Newport Beach Operations (FACC)
ORC	Organic Rankine Cycle
PCA	Power-Conversion Assembly (receiver plus PCS)
PCS	Power-Conversion Subsystem
PDC-1	Parabolic Dish Concentrator No. 1 (GE design)

PDC-2      Parabolic Dish Concentrator No. 2 (Acurex design)

PDTS      Parabolic Dish Test Site (JPL test facility at Edwards AFB)

PFDR      Point-Focusing Distributed Receiver

PMA      Permanent Magnet Alternator

PNL      Battelle Pacific Northwest Laboratories

RAM      Random Access Memory

RCIA      Remote Control Interface Assembly (computer for module control)

ROP      Remote Operational Program

RTD      Resistance Temperature Detector

SERI      Solar Energy Research Institute

SCSE      Small Community Solar Thermal Power Experiment

TAP      Turbine/Alternator/Pump

TBC      Test Bed Concentrator

TBD      To Be Determined

TFR      Trouble/Failure Reports

TP      Test Procedure

UPS      Uninterruptible Power Supply

## CONTENTS

I.	INTRODUCTION . . . . .	1-1
A.	McDONNELL-DOUGLAS ASTRONAUTICS COMPANY . . . . .	1-2
B.	GENERAL ELECTRIC COMPANY . . . . .	1-2
C.	FORD AEROSPACE AND COMMUNICATIONS CORPORATION. . . . .	1-3
II.	THE MULTI-MODULE PLANT . . . . .	2-1
A.	BACKGROUND . . . . .	2-1
B.	REQUIREMENTS FOR A 100-kWe, MULTI-MODULE PLANT . . . . .	2-2
1.	System Definition and Objectives . . . . .	2-2
2.	General Description. . . . .	2-3
3.	Assemblies, Power Module, and Power Plant. . . . .	2-7
4.	System Rated Power . . . . .	2-7
5.	Operating Limit. . . . .	2-9
6.	Efficiency/Performance . . . . .	2-9
7.	Electrical Energy Requirements . . . . .	2-9
8.	Plant Operation. . . . .	2-9
9.	Module Operation . . . . .	2-12
10.	Utility Interfaces . . . . .	2-12
11.	Design Service Life. . . . .	2-12
12.	Reliability/Availability . . . . .	2-12
13.	Environmental Conditions . . . . .	2-12
III.	DEVELOPMENT OF COMPONENTS AND SUBSYSTEMS FOR THE ORC POWER MODULE . . . . .	3-1
A.	CONCENTRATOR . . . . .	3-1
1.	General Characteristics. . . . .	3-1
2.	Parabolic Dish Concentrator No. 2 Subsystem Description . . . . .	3-3



3.	Interface Definition . . . . .	3-5
4.	Operational Criteria . . . . .	3-8
5.	Environmental Conditions . . . . .	3-9
6.	Other Environments . . . . .	3-10
7.	Inspection and Maintenance . . . . .	3-10
8.	Mirrors . . . . .	3-11
9.	Overall Characteristics . . . . .	3-11
B.	THE POWER-CONVERSION ASSEMBLY. . . . .	3-11
1.	Description of the Power-Conversion Assembly . . . . .	3-13
2.	Receiver . . . . .	3-15
3.	The Power-Conversion Subsystem . . . . .	3-19
C.	ENERGY TRANSPORT SUBSYSTEM . . . . .	3-25
D.	THE CONTROL SUBSYSTEM. . . . .	3-27
IV.	DEVELOPMENT TESTS OF THE ORC MODULE COMPONENTS AND SUBSYSTEMS . . . . .	4-1
A.	POWER-CONVERSION ASSEMBLY VERIFICATION TEST AND ENERGY TRANSPORT SUBSYSTEM QUALIFICATIONS . . . . .	4-3
B.	TEST OBJECTIVES . . . . .	4-4
1.	Primary Objectives . . . . .	4-4
2.	Secondary Objectives . . . . .	4-5
C.	TEST CONFIGURATION . . . . .	4-5
1.	Test Operations . . . . .	4-9
2.	Test Parameters . . . . .	4-9
D.	TEST RESULTS . . . . .	4-12
1.	The Concentrator . . . . .	4-17
2.	The Receiver . . . . .	4-17
3.	Power-Conversion Subsystem . . . . .	4-17
4.	Toluene Analysis . . . . .	4-21

5.	The Energy Transport System . . . . .	4-25
6.	Overall System Performance . . . . .	4-27
V.	CONCLUSIONS AND RECOMMENDATIONS. . . . .	5-1
	REFERENCES . . . . .	6-1
APPENDIXES		
A.	THE CARTER STEAM ENGINE. . . . .	A-1
B.	SAMPLE PRINTOUT OF ALL DISPLAYS . . . . .	B-1
C.	DOCUMENTATION. . . . .	C-1

Figures

Frontpiece:	One-Megawatt Experimental Plant Originally Proposed for the Small Community Solar Thermal Power Experiment (SCSE). . . . .	xii
2-1.	SCSE System Schematic (Power Plant) . . . . .	2-4
2-2.	SCSE Power Module Configuration Using the Acurex PDC-2 Concentrator . . . . .	2-5
2-3.	Power-Conversion Assembly (PCA) . . . . .	2-8
3-1.	Scale Models of Proposed Concentrators . . . . .	3-2
3-2.	Mirrored Cellular Glass Gore . . . . .	3-4
3-3.	Power-Conversion Subsystem . . . . .	3-14
3-4.	Schematic Diagram of ORC Power Conversion Assembly . . . . .	3-16
3-5.	Diagram of Pressure/Enthalpy for the Organic Rankine Cycle . . . . .	3-17
3-6.	Cut-Away View of Receiver Assembly . . . . .	3-19
3-7.	Turbine/Alternator/Pump (TAP) Assembly . . . . .	3-22
3-8.	Relationship Between Turbine Power Output and Speed for Various Thermal Inputs . . . . .	3-24

3-9.	Effect of Variations in Current (or Power) Output for Alternators with Predetermined Internal Impedance Feeding a Variable Load . . . . .	3-25
3-10.	Cross Section of TAP Assembly Showing, to Scale, Relative Sizes and Locations of Various Components . . . . .	3-26
3-11.	Block Diagram of Single Power-Module Electrical Power Output Equipment . . . . .	3-28
3-12.	Vapor-Valve Control Law . . . . .	3-30
3-13.	Typical Plant Moding Hierarchy . . . . .	3-32
4-1.	Power-Conversion Assembly and Electrical Boxes on Test Bed Concentrator No. 1 . . . . .	4-6
4-2.	Comparison of Predicted and Measured Receiver Wall Temperatures (Runs 13 and 17) . . . . .	4-7
4-3.	Simplified Schematic Diagram of Single-Module Experiment Hardware at Parabolic Dish Test Site. . . . .	4-8
4-4.	Test Bed Concentrator with 25% Checkerboard Masking Pattern . . . . .	4-11
4-5.	TV Monitor Showing 25% Masking Spots on Back Wall of Receiver . . . . .	4-11
4-6.	Typical Receiver Efficiency Plot (Run 16, Test No.11) . . . . .	4-18
4-7.	Receiver Fluid Outlet Temperature vs. Valve Position (Run 13, Test No. 8) . . . . .	4-19
4-8.	Receiver Temperatures for Run 13 (Test No. 8) . . . . .	4-20
4-9.	Power-Conversion Subsystem Performance History for Run 13 (Test No. 8) . . . . .	4-22
4-10.	Measured ORC Engine Efficiency . . . . .	4-24
4-11.	Inverter Efficiency Data and Pre-Test Predictions . . . . .	4-28
4-12.	Measured Component, Module, and System Performance for a Typical Run . . . . .	4-30

Tables

2-1.	Efficiency/Performance Goals and Minimum Values at Rated Conditions . . . . .	2-10
------	---	------

2-2.	Electrical Energy Requirements and Grid Characteristics . . . . .	2-11
3-1.	PDC-2 Summary . . . . .	3-12
3-2.	Power-Conversion Subsystem Characteristics and Specification Summary . . . . .	3-20
4-1.	Tests Performed During Development of the Organic Rankine Power Module . . . . .	4-2
4-2.	Test Parameters . . . . .	4-10
4-3.	Parabolic Dish Test Site Test Summary . . . . .	4-13
4-4.	Power-Conversion Subsystem Test Data at Parabolic Dish Test Site . . . . .	4-23
4-5.	Inverter Requirements . . . . .	4-26

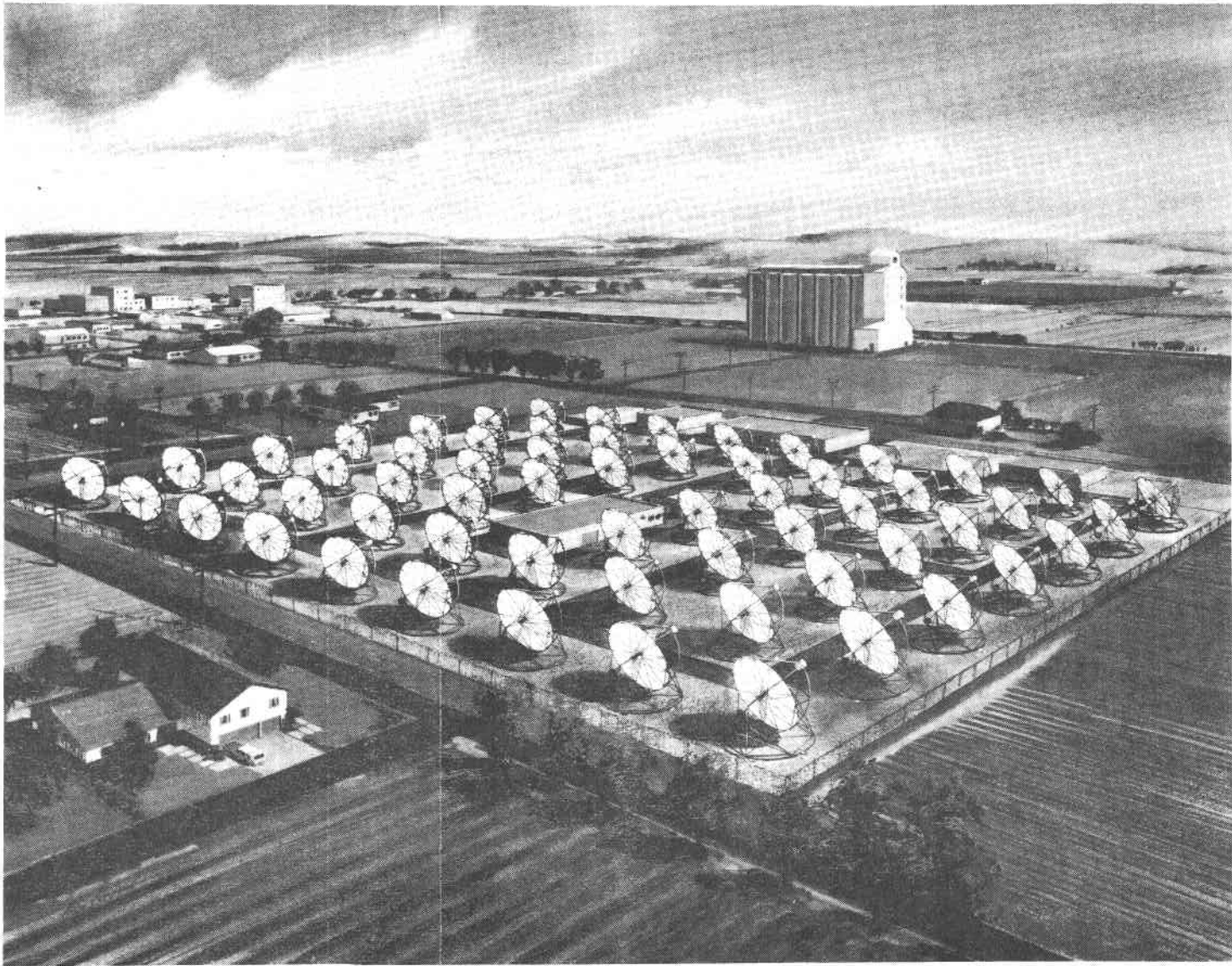

One-Megawatt Experimental Plant Originally Proposed for the Small Community Solar Thermal Power Experiment (SCSE)

## SECTION I

### INTRODUCTION

This report deals with the design, development, and test of an organic (toluene) Rankine-cycle (ORC) power module that was intended for the Small Community Solar Thermal Power Experiment (SCSE). Although much has been written about the program, most of the information has appeared in contract documents that have not been widely distributed and is, therefore, not readily available to workers in the field. The objective of this summary and discussion of programmatic considerations and constraints is to identify relevant publications and to discuss the rationale behind many of the decisions that were made in the course of the development of this technology.

The time period covered by this report is from 5 July 1978 to 1 August 1983, beginning with the Phase I effort and ending with the formal termination of the Jet Propulsion Laboratory (JPL) cognizance of the Ford Aerospace and Communications Corporation (FACC) Phase II effort. Some of the results presented herein were actually obtained after 18 November 1983 when FACC began Phase III under an interim letter contract with the U.S. Department of Energy (DOE). Also, references are cited in this report that were published after the official cut-off date but which contain results that might prove useful in the design, fabrication, or operation of potential future ORC engine designs.

The Experiment had its beginnings in 1977 when Congress, responding to strong and continuous community pressure, sought to provide alternative electric power supplies that could demonstrate reduced dependence on non-renewable energy sources. To help meet this problem, Congress appropriated funds for a 5-MWe solar thermal demonstration, but the proposed plant later was reduced in size to 1 MWe when it was decided that a smaller facility would provide a valid model at lower cost. Subsequently, its size was to be reduced even further. The technical programs undertaken at JPL were augmented by market and commercialization studies to establish cost goals that might serve as a basis for engineering decisions and performance evaluation.

To ensure that all solar thermal technology options would be considered, a concept-definition phase was initiated in which competitive studies were to be performed in each of three categories:

- (1) Category A - General (to include, but not be limited to, central-receiver and line-focusing systems).
- (2) Category B - Point-focusing concentrators, distributed receivers, central-power conversion.
- (3) Category C - Point-focusing concentrators, distributed receivers, power conversion at each concentrator.

A multiphase approach was adopted as the best means of meeting the objectives of the experiment in the shortest period of time. Phase I addressed the problem of exploring all competitive technologies for this application and recommended those that should be studied in greater detail. Competitive bids were received in each of the categories listed above, and awards were made on the basis of merit. One contractor was selected in each category.

In Phase I each contractor was asked to develop a preferred system concept, to perform sensitivity analyses, and to outline recommended approaches for the follow-on Phase II design program. The systems recommended by the contractors in each of the categories and a brief description of each system follows.

- A. McDONNELL-DOUGLAS ASTRONAUTICS COMPANY: Central tower with field of south-facing heliostats (Reference 1-1).

The system proposed by the McDonnell-Douglas Astronautics Company (MDAC) was similar in principle to the 10-MWe, central-receiver solar plant (later known as "Solar One") then under construction (and now operating) near Barstow, California, in conjunction with the Southern California Edison Company. The proposed plant and tower were smaller in size, and the field of heliostats were to be distributed south of the tower rather than surrounding it, as in the Barstow plant. The receiver was a partial cavity-cone design, consisting of an absorber unit, structural assembly (including housing and doors) instrumentation, insulation, and heaters. The tower assembly was to be a guy-wire-supported lattice structure 131 ft high supporting the receiver as well as the thermal transport fluid (HITEC) riser and downcomer.

In this system, the energy transport subsystem collects thermal energy from the receiver and transports it to the energy storage subsystem and then to the power-conversion subsystem. HITEC was proposed as the transport fluid because of its relatively low melting temperature (142°C) and because of the vast experience accumulated with it in industrial process applications. Steam produced from the steam generator was to drive a steam Rankine-cycle turbine coupled to an electrical generator to produce electricity. A power plant building housed the entire power-conversion subsystem, with the exception of the cooling tower and waste-water pond. The balance of plant used equipment and techniques similar to those used in oil-fired or gas-fired steam power plants.

- B. GENERAL ELECTRIC COMPANY: A field of parabolic dishes with steam piped to a central turbine-generator unit (Reference 1-2).

The General Electric concept borrowed heavily from the plant designed by GE as a total energy system for the Bleyle plant at Shenandoah, Georgia (the Shenandoah Total Energy System). This design made use of a field of GE-designed concentrators (Parabolic Dish Concentrator No. 1, also called PDC-1) to generate steam, which was then transported through low-loss piping to a central steam turbine generator unit. The collector field was divided into two sections: those dishes that carried saturated steam, and dishes that

extended the heating into the superheat range. The central steam turbine and balance of the plant were to be adaptations of existing, well-proven components.

- C. FORD AEROSPACE AND COMMUNICATIONS CORPORATION: A field of parabolic dishes with a Stirling-cycle engine/generator unit at the focus of each dish (Reference 1-3).

The system concept originally selected by Ford Aerospace and Communications Corporation in the Phase I study comprised multiple dish concentrators employing a Stirling-cycle heat engine with direct-coupled ac generators at the focal point of each concentrator. The basic power module consisted of parabolic concentrators 18.6 m in diameter using the United Stirling (Sweden) P-75 Stirling-cycle engine for power conversion. Each module included the parabolic concentrator and a cavity receiver with an integral sodium pool boiler, sodium thermal-transport hardware, and the engine/generator assembly. The proposed parabolic dish concentrator was to be a front-braced design with an azimuth-elevation mount and tripod structure with a reflector surface composed of back-silvered, high-reflectivity mirror segments made of fusion glass.

Soon after the completion of the Phase I studies, DOE directives and ongoing technical studies at JPL and elsewhere produced two important programmatic changes:

- (1) Category A (and with it the system recommended by McDonnell-Douglas Astronautics Company) was eliminated by DOE from further participation in subsequent phases of the experiment to achieve better program balance because the central-tower concept was already under development at Barstow.
- (2) Budget constraints, combined with promising and timely results in the Point-Focusing Distributed Receiver Technology (PFDRT) development program at JPL, dictated that subsystem development within the experiment be minimized. Instead, designs for appropriate subsystems were to come from ongoing development work or from other existing sources. PDC-1 was considered the most promising concentrator for use with the experiment. Meanwhile, results of the technology comparison studies performed at the Solar Energy Research Institute (SERI) and at the Battelle Pacific Northwest Laboratories (PNL) indicated that distributed-power generation was preferred to central-power generation when using point-focus technology for 1-MW plants without storage. In addition, the Shenandoah Total Energy Project was scheduled for completion prior to the Small Community Experiment and would thus serve as verification and demonstration of the point-focusing, central-generation concept. These factors, in addition to the JPL evaluation of the technology choices for this experiment, led to a decision to select Category C and to proceed with this approach in Phase II. As a result, FACC (the successful contractor in this category) was selected to continue in Phase II. On the basis of lowest predicted energy costs, FACC recommended the Stirling-cycle



engine, with the Rankine-cycle engine its second choice. In light of ongoing engine studies at Lewis Research Center and at JPL, which indicated that Stirling engine receiver technology was not yet ready for field experiments, it was decided to incorporate a Rankine-cycle engine in the configuration selected for design and test in Phases II and III.

## SECTION II

### THE MULTI-MODULE PLANT

#### A. BACKGROUND

In August 1979, a sole-source RFP was sent to Ford Aerospace and Communications Corporation soliciting its participation to act as system contractor for Phase II of the experiment. The contractor was required to conduct a preliminary design, component and subsystem development, subsystem and system-level verification testing, and detailed design for a multi-module plant. FACC was also asked to complete the plans for site preparation and hardware implementation. The technology was restricted to distributed energy conversion using the Rankine-cycle engine.

At this point neither the working fluid nor the engine configuration had been determined although the system recommended by FACC in their proposal made use of the organic Rankine-cycle engine with a turbine expander. A special ad hoc committee was formed, consisting of personnel from JPL, LeRC, and SERI to evaluate the readiness of the available Rankine engines because it was considered important to select an engine that required a minimum amount of time and money to develop or adapt for solar use. It was of prime importance that the selected engine not constitute a risk to the success of the experiment.

The committee, which visited the facilities of manufacturers of Rankine-cycle, organic-fluid, and steam engines, found that off-the-shelf designs did not exist and that some development work would be required, regardless of which technology was selected. The evaluation process drew heavily on previous NASA Lewis Research Center experience and studies (References 2-1, 2-2, 2-3) aimed at identifying concepts suitable for paraboloidal dish applications. The number of candidates was reduced to two: (1) the steam-reciprocator engine and (2) the organic-fluid turbine. Although the committee was inclined to favor the steam-reciprocator engine (e.g., the engine described in Appendix A) from the viewpoint of cost and risk, the potential for long life with low maintenance caused the project management to concur with the alternative recommended by FACC. The configuration selected was one using the organic (toluene) Rankine-cycle engine, hermetically sealed, with a permanent magnet alternator integrally mounted on the single-stage, high-speed turbine shaft.

Because the power module and its subsystems and components were designed and tested (for test evaluations, see Section IV and Appendix B) to be used in the multi-module plant of the Small Community Solar Thermal Power Experiment, a description of the proposed complete experimental facilities plant is necessary for a complete understanding and evaluation of these elements. For that reason, the description and specifications for those portions of the intended multi-module plant that would have significantly impacted the design of the power module are given in the following paragraphs. For the greater part, these descriptions were taken from the Critical Item Specification documents written by FACC during the course of the development. A complete listing of applicable specification documents can be found in Appendix C.

Although a 1-MWe plant was originally proposed for the experiment, the rating of the proposed plant was ultimately reduced to 100-kWe as a result of several decisions made during the course of the development program. In spite of this reduction in plant size, the design of the power module itself was not significantly affected. Only those items involving central control and energy collection and transport were altered to accommodate the reduced number of modules.

Indeed, an increase in module size was ultimately proposed for the Phase III plant<sup>1</sup> as a means of increasing the plant output rating when it became apparent that FACC would not be able to build a 100-kWe plant under the cost constraints required by DOE. The solution to this dilemma was to reduce the plant cost by reducing the number of modules while increasing the rated power output of each module. Some of this increase was to be achieved by enlarging the proposed concentrator diameter to 12.2 m (thereby increasing the flux impinging on the receiver) while some improvement was realized by refinements in engine-component design. The remaining increase came as a result of changes in the rating system itself and in the assumed ambient conditions of operation. In the ensuing descriptions and tables, the descriptions and values presented typically apply to the elements of the final multi-module plant design with each module rated at approximately 25 kWe. This 25-kWe module and the original 20-kWe module are individually identified wherever a distinction between the two units is required in this report. In all cases, the size of the total multi-module plant is 100 kWe.

## B. REQUIREMENTS FOR A 100-kWe, MULTI-MODULE PLANT

The following description and requirements were established to define and control the design and development of the multi-module plant. Except for minor editorial changes and abridgement, they are quoted from Reference 2-4.

### 1. System Definition and Objectives

The Small Community Solar Thermal Power Experiment<sup>2</sup> is based on a modular, point-focusing, distributed-generation type of solar thermal electric system and commonly designated as a PFDR or "Point-Focusing Distributed Receiver." The system is comprised of multiple point-focusing concentrators using Rankine-cycle heat engines with directly coupled ac generators for power conversion at the focal point of each concentrator. Electrical energy is transported from the module-mounted energy conversion equipment to the collection point for power conditioning and transmission to the utility network.

---

<sup>1</sup>The specifications for the 25-kWe module, 100-kWe plant are based on Reference 2-4.

<sup>2</sup>The plant proposed for this experiment did not go beyond the preliminary design stage. Although intended for deployment at Osage City, Kansas, this specific plant was never built.

The objectives of the SCSE multi-module plant are twofold:

- (1) To establish technical feasibility of small, solar-thermal, point-focusing, distributed receiver technology in a small community/utility environment.
- (2) To determine performance, functional, and operational characteristics of the selected system in a user environment.

## 2. General Description

The SCSE power plant consists of multiple power modules connected to a central control building by electrical power lines and instrumentation/control cables. The control building serves as the collection point for further power conditioning. Interface equipment is used to connect the output power to the local utility grid. The plant consists of four major subsystems:

- (1) Collector Subsystem.
- (2) Power-Conversion Subsystem (PCS).
- (3) Energy Transport Subsystem (ETS).
- (4) Plant Control Subsystem.

These subsystems are identified on the system schematic shown in Figure 2-1. The power module is shown in Figure 2-2 and consists of the collector subsystem and the power-conversion assembly (PCA), comprising the receiver, engine, and those associated electricity-generating components mounted at the focus of the dish.

a. Collector Subsystem. The collector subsystem consists of the sun-tracking parabolic concentrator and receiver subassembly. The concentrator collects solar radiation and focuses it on the receiver wall. The Acurex Parabolic Dish Concentrator No. 2 (PDC-2) shown in Figure 2-2 is proposed for this application. The receiver transforms the radiant energy to thermal energy and transfers it to the fluid medium for transport to the power-conversion subsystem.

b. Power-Conversion Subsystem (PCS). The power-conversion subsystem converts the thermal energy from the receiver subassembly to electrical energy. The power-conversion subsystem consists of the components supplied by the PCS subcontractor, Barber-Nichols Engineering:

- (1) Components located at the focal point.
  - (a) Turbine/Alternator/Pump (TAP)
  - (b) Regenerator

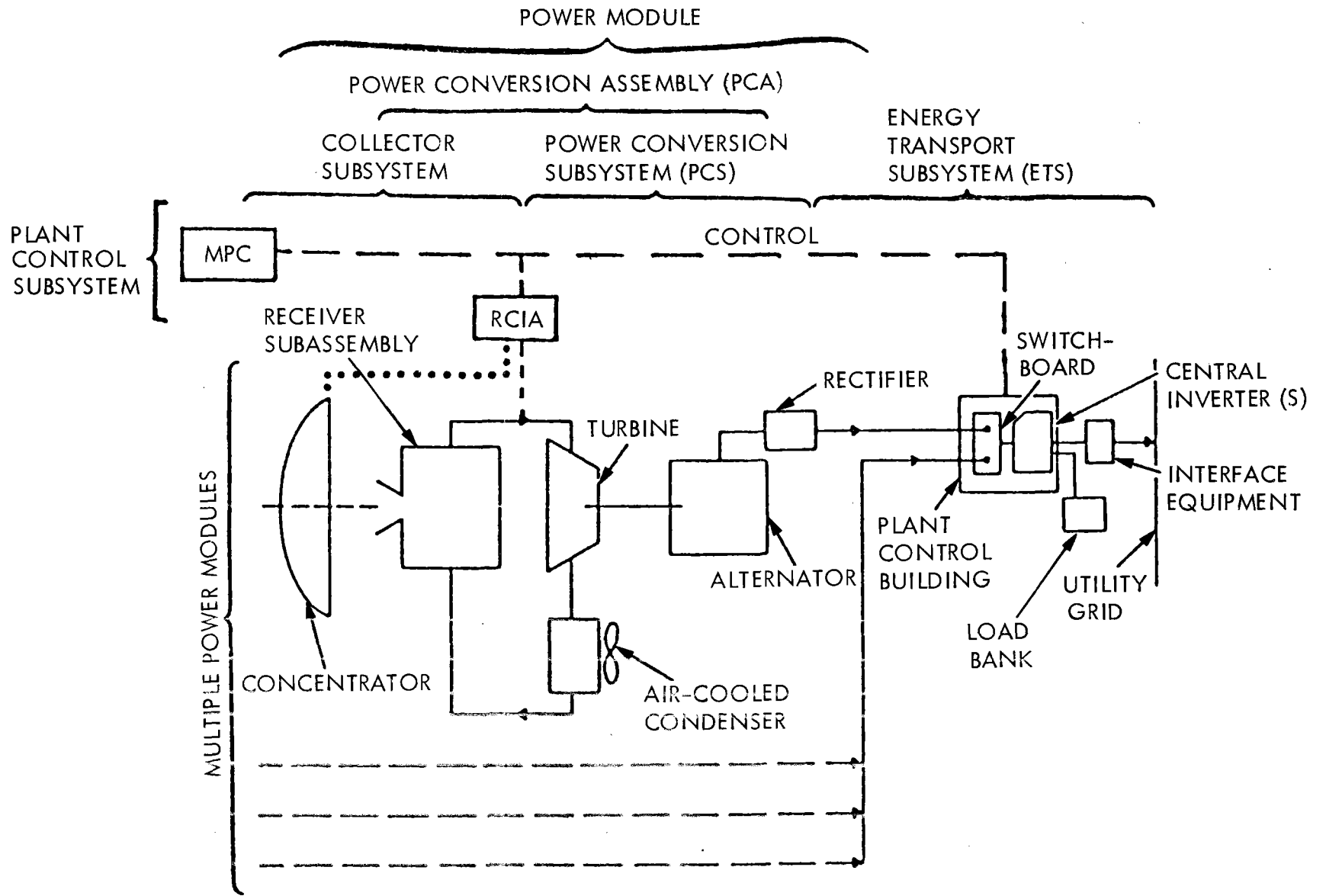

Figure 2-1. SCSE System Schematic (Power Plant)

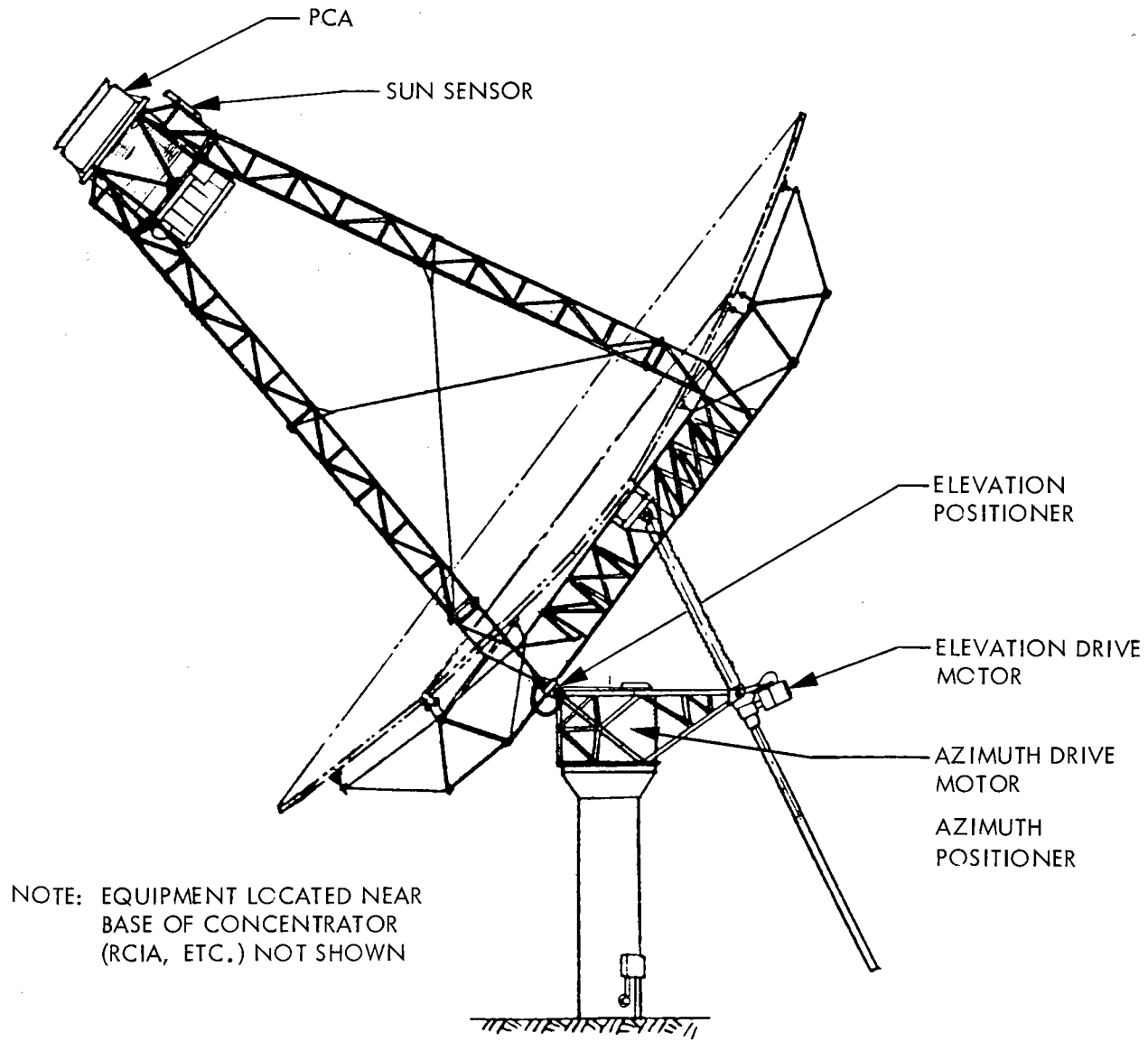

Figure 2-2. SCSE Power Module Configuration Using the Acurex PDC-2 Concentrator

- (c) Condenser and fan
  - (d) Control valve
  - (e) Plumbing and ancillary equipment
- (2) Rectifier.
  - (3) PCS controls.
  - (4) Brake (electrical).
  - (5) Motor starters.
  - (6) Fan control.

c. Energy Transport Subsystem. The energy transport subsystem (ETS) is used to carry electrical energy from the individual power modules to the collection point and then to the local utility grid. The subsystem consists of the following major components:

- (1) Electrical power cables.
- (2) Switchboard.
- (3) Central inverter(s).
- (4) Load bank(s).
- (5) Grid-interface equipment.

d. Control Subsystem. The control subsystem consists of the hardware, software, and facilities necessary for the operation and monitoring of all subsystems, components, and plant-level functions. The key components are the Master Power Controller (MPC) and the Remote Control Interface Assembly (RCIA). Computational functions are performed in both the MPC and the RCIA: the MPC uses the Data General Eclipse S/120 minicomputer and the RCIA uses the Z-80 microprocessor. The MPC acts as the command center for mode control<sup>3</sup> and other central-control functions for the entire plant. The RCIA provides detailed control of the concentrator and PCA, data encoding, power-module automoding, and communication with the central MPC. One RCIA is assigned to each power module, i.e., it is the local control unit for each module under the overall control of the MPC. The building that houses the central control equipment is classified as part of the control subsystem

---

<sup>3</sup>Mode control includes normal plant operations such as start-up, normal operation and shutdown; abnormal operations such as an environmental shutdown or an individual power-module failure; and plant-wide emergency conditions such as utility-grid failure, MPC failure, or failure of other critical components in the energy-transport subsystem.

although it also contains the switchboard, inverter, and other electrical equipment.

### 3. Assemblies, Power Module, and Power Plant

a. Power-Conversion Assembly (PCA). The PCA consists of the hardware installed at the focal point. It has two major parts (Figure 2-3) connected to form an integral unit:

- (1) Receiver Subassembly. All receiver components, including heat-transfer surfaces, insulation, attach structure, etc.
- (2) Power-Conversion Subsystem Components. The PCA includes all the PCS components located at the focal point. (Other PCS components, such as the rectifier, are mounted on the ground near the concentrator and are not part of the PCA.) Figure 2-3 illustrates the location of the major components that comprise the PCA.

b. Power Module. The power module consists of the concentrator, the PCA, and equipment located near the concentrator base, i.e., the rectifier, PCS control box, brake, fan control, motor starters, RCIA, PDC-2 control, and local cabling.

c. Power Plant. The power plant consists of items identified in Figure 2-1: multiple power modules, energy-transport subsystem, and control subsystem. All the components shown in Figure 2-1 are part of the power plant. This includes the central-control building and ancillary components, such as an uninterruptible power supply (UPS).

### 4. System Rated Power

The plant shall deliver at least 100 kW<sub>e</sub> net electrical power to the local grid at rated conditions. Net power is defined as that produced after deducting power consumption associated with individual modules. Parasitic power to operate central equipment such as the MPC, inverter, lights, and air conditioning is not included because these requirements are essentially independent of plant size. Rated conditions are defined as follows:

- (1) A direct normal insolation of 1.0 kW/m<sup>2</sup> available to the concentrator (circumsolar flux not included).<sup>4</sup>

---

<sup>4</sup>The selection of this insolation value is best explained in the SCSE Technical Report TR-SCSE-009 (See Appendix C).



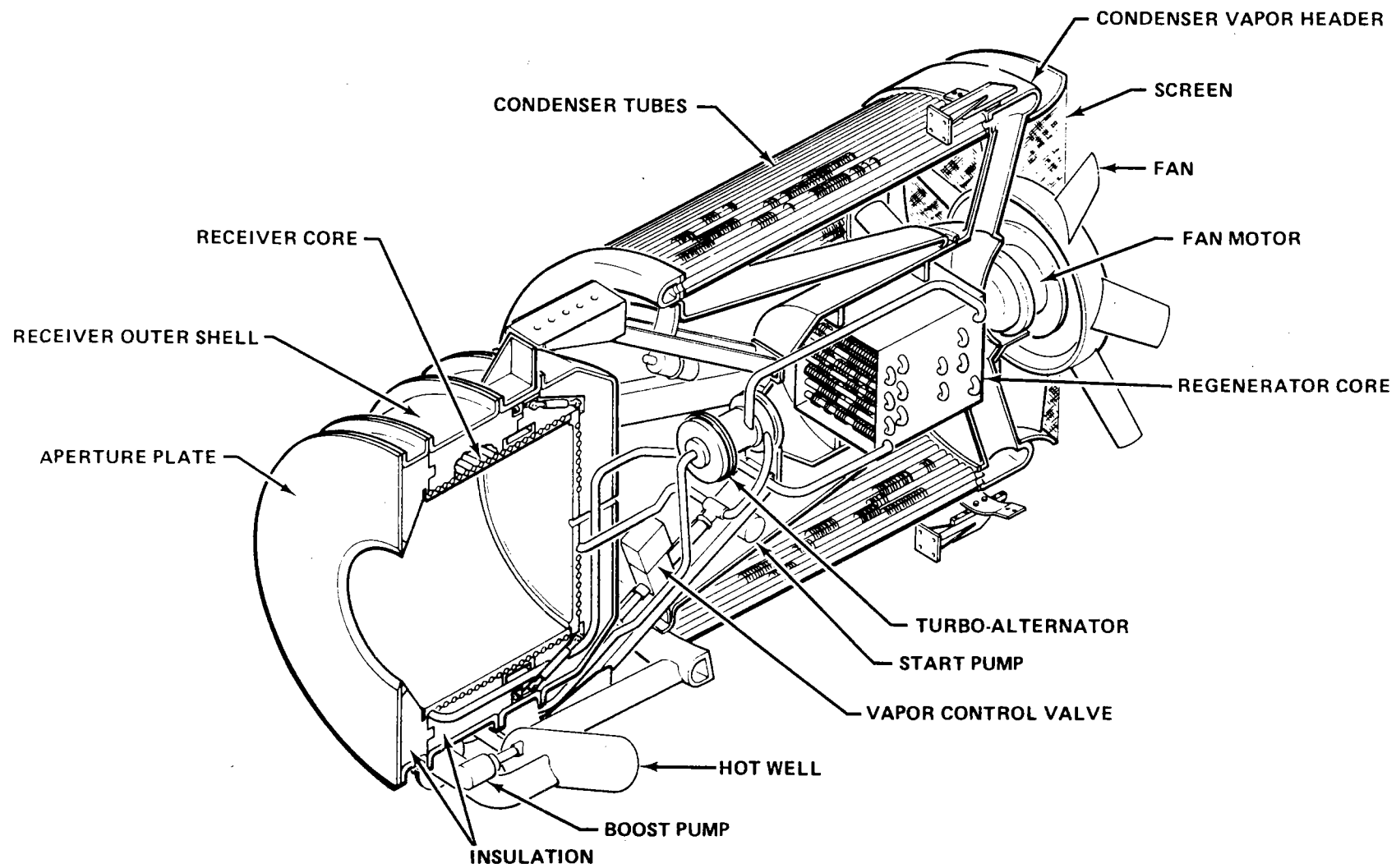

Figure 2-3. Power-Conversion Assembly (PCA)

(2) Ambient temperature: 0°C (32°F).

(3) Wind speed: 0.

Appropriate scaling techniques shall be used to ratio the actual output to rated conditions.

#### 5. Operating Limit

The plant shall operate properly at an insolation of 1100 W/m<sup>2</sup> with clean reflectors.

#### 6. Efficiency/Performance

The efficiency of the plant, subsystems, and components shall be maximized, consistent with design and program constraints. The efficiency or performance goals and minimum levels at rated conditions are summarized in Table 2-1.

#### 7. Electrical Energy Requirements

The electrical energy supplied to the utility grid shall meet the requirements in Table 2-2. The grid characteristics under which these are met are also identified in Table 2-2.

#### 8. Plant Operation

The system shall exhibit stable, controlled, and safe operations during start-up, normal operation, shutdown, emergency, and intermittent operation.

The plant shall be capable of automatic operation by the on-site, plant control subsystem. With the future addition of communication equipment the design shall be capable of remote operation by the utility power dispatcher without assistance from on-site operators. Automatic or autonomous operation shall be implemented by computer logic structured in a hierarchy involving the plant, the ETS, the power modules, the PCAs, and the concentrators. Plant modes and ETS modes will be controlled by the central computer or MPC; power-module, PCA, and concentrator modes shall be controlled by the local microprocessor, i.e., the RCIA.

Typical plant-operating modes and features, each involving combinations of the lower-level modes, are described below.

a. "Ready" Plant Mode. The "ready" mode is initiated first. When the computer has determined that all conditions are met for power generation (i.e., minimum insolation, sun elevation angle above 5 deg, etc.) the logic will progress to the next mode, provided there are no fault flags. The concentrators remain in the stowed condition in this mode.

Table 2-1. Efficiency/Performance Goals and Minimum Values at Rated Conditions

Component/Item	Efficiency or Performance Parameter	
	Goal	Minimum
Concentrator	Produce 101 kWt through a 37.95-cm (14.94-in.) aperture	98.2 kWt through the aperture
Receiver	97%	96%
PCS (Engine/Alternator/Rectifier), based on gross output and 427°C (800°F) turbine inlet temperature	30.2%	27.5%
Energy Transport Sub-system <sup>a</sup> (cables, switchboard, and inverter; transformer not included)	91.6%	88.7%
Module Parasitic Losses (N = no. of modules)	0.92 N kWe	1.2 N kWe
Plant Output	110 kWe at rated conditions	100 kWe at rated conditions

<sup>a</sup> Based on a subscale inverter efficiency of 90% (minimum) or 93% goal. An ETS efficiency of 96.5% is predicted for a full-size plant.

b. "Normal Power" Plant Mode. When this mode is entered, the power modules cycle through the following sequence: (1) slew to offset track, (2) self test, if OK, then (3) slew on sun, and (4) power generation following receiver heat-up. This mode will continue until some condition occurs that signals the computer to shut down the modules. During periods in which the PCS is producing power, the RCIA will attempt to control the fluid flow to maintain a constant fluid temperature at the outlet of the receiver. If this is not possible due to cloud cover or other reasons, idle conditions will be maintained as long as practical.

c. "Normal Shutdown" Plant Mode. Collection of solar energy will be terminated when insolation falls to the level at which no net energy

Table 2-2. Electrical Energy Requirements and Grid Characteristics

Parameter	Electrical Energy Supplied by SCSE	Grid Characteristics
Voltage (nominal)	480 V, 3-phase from inverter, transformed by site participant to match grid voltage of 2400 V.	2400, 30, <u>+10%</u> voltage variation
Voltage Regulation	Follow grid variations	Voltage variations of <u>+10%</u>
Frequency	Synchronize with grid frequency	60 Hz <u>+2</u> Hz
Waveform Distortion	<5% total harmonic output current at rated conditions	Not applicable
Regulation Time Constant	2 cycles for inverter	Not applicable
Effective Power Factor (PF)	0.95 <u>+0.05</u> supplied to grid by inverter when providing 75% of rated power	-0.7 to +0.7 for SCSE operation. Rated output of plant at 0.95 <u>+0.05</u> grid PF

can be collected. When this occurs, or when shutdown is directed for some other reason (such as adverse weather), all modules will be shut down and stowed.

d. "Emergency Shutdown" Plant Mode. The plant control subsystem will monitor the status of each subsystem during all operations and will diagnose subsystem malfunctions. In the event a malfunction is deemed "serious" (leading to potential equipment damage or safety hazard), an emergency shutdown procedure will be initiated automatically. Manual backup will also be available. The procedure depends on the nature of the failure but in all cases is designed to maximize safety while minimizing equipment damage.

The plant automatically disconnects from the grid in the case of a grid malfunction. When the fault has cleared and any tripped manual relays reset, the plant may return to automatic control by the operator and be reconnected to the grid.

e. "Standby" Plant Mode. Following normal shutdown or emergency shutdown, the system is placed in a standby mode. In this mode the control subsystem will continue automatically to monitor temperatures and activate elements, as required to maintain the system in a ready condition for subsequent start-up. The concentrator will usually be located in the offset track position during standby.

f. Extended Shutdown ("Out of Service") Plant Mode. This mode disables the power modules and thus provides a safe means of making maintenance, repair, or equipment modifications.

#### 9. Module Operation

Each module of the plant shall be capable of operation independently of the other modules. If a malfunction occurs that is associated with an individual module and that may lead to equipment damage or a safety hazard, that module shall be automatically shut down, with manual backup. Modules not associated with the malfunction shall continue operating. Each module, as well as other major elements of the plant, shall be capable of being independently shut down or removed from plant operations for maintenance, repair, or modification.

#### 10. Utility Interfaces

The system shall be compatible with standard electric power transmission networks and meet the requirements in Table 2-2.

#### 11. Design Service Life

The plant shall be designed for an operational lifetime of 20 years, the standard for the solar industry.

#### 12. Reliability/Availability

Design, fabrication, assembly, and checkout approaches shall be used that maintain a high level of reliability and availability, consistent with the size and purpose of the plant. High reliability and availability shall be achieved in the system design by providing adequate operating margins, using proven standard designs and procedures, maintaining design simplicity, and using conservative design and operational practices.

#### 13. Environmental Conditions

The plant shall be capable of operating in, and surviving, appropriate combinations of environmental conditions that exist at Edwards AFB, California, or Osage City, Kansas (See Footnote 2). These conditions include insolation, temperature extremes, winds and gusts, dust and

sandstorms, rain, hail, snow and ice, humidity, freezing and thawing, seismic loads, and lightning, as defined in the following paragraphs.

a. Insolation. Plant performance predictions over a specified period of time shall be based on direct, normal insolation data obtained at the Osage City site. Rated conditions shall be based on the 1.0 kW/m<sup>2</sup> condition (See Footnote 4). The maximum direct normal insolation for plant operation shall be 1100 W/m<sup>2</sup>.

The plant shall operate properly at the maximum rate of change of incident flux resulting from the passage of the shadow from an opaque cloud moving across the collector field at a velocity of 20 m/s.

b. Temperature.

Survival. The plant shall be able to survive, without damage, ambient air temperatures in the range of -26°C (-15°F) to 50°C (122°F). Exposed elements shall also be able to be subjected to the heat load from a maximum insolation condition of 1100 W/m<sup>2</sup>.

Operating conditions. The plant shall be able to operate continuously when the ambient temperature is between -10°C (15°F) and 46°C (115°F). Components with a restricted range of operating temperature shall be placed in a conditioned enclosure -- primarily the central computer, which is restricted to ambient conditions of 10° to 32°C (50 to 90°F).

c. Winds and Gusts. The wind shall be measured 10 m (33 feet) above ground level. Wind gusts, which are superimposed on the average wind speeds, may occur at any time. A 20% increase in wind velocity during a 2-s duration (2-s triangular pulse) shall be used to model typical gusts; the resulting loads should not result in any equipment damage.

Operating Conditions. The concentrators shall be capable of operating within specification in a 4.5-m/s (10-mph) wind. Safe operation without damage to any module component shall occur in wind speeds to 11.2 m/s (25 mph), at which point the concentrators shall be commanded to stow.

The following conditions shall be used as a guide for wind-rise rate, velocity profile, and frequency. A maximum wind-rise rate of 0.01 m/s<sup>2</sup> (1.3 mph/min) and the appropriate level of wind gusts shall be used in calculating wind loads during slew-to-stow. Wind-velocity profile varies exponentially with height to the 0.15 power, where the reference height is taken as 10 m (33 feet):

$$V_z = V_{10 \text{ m}} \left( \frac{z}{10 \text{ m}} \right)^{0.15}$$

where

$V_{10\text{ m}}$  = reference wind velocity at a height of 10 m

0.15 = power law exponent for flat open country

Z = height in meters

$V_z$  = mean wind velocity at height Z

d. Dust and Sandstorms. The plant shall survive, without damage, blowing dust equivalent to the conditions at the Parabolic Dish Test Site (PDTS) at Edwards AFB or at Osage City, Kansas, whichever is more severe.

e. Rain, Snow, Ice, and Hail. The plant (with the concentrators in the stowed position) shall survive, without damage, the environmental conditions established for the concentrator (See Section III-5).

f. Combined Environments. The plant (with the concentrators in the stowed position) shall survive, without damage, realistic combinations of adverse environmental conditions (e.g., high winds with ice on the concentrator or high humidity).

g. Seismic. The plant shall survive, without structural damage or yielding, an earthquake that produces an acceleration of 0.25 g horizontal in any direction, combined with a vertical earthquake acceleration of 0.17 g superimposed on a normal 1-g gravity load. The spectrum presented in U.S. Atomic Energy Commission Regulator Guide 1.60 (Revision 1, dated December 1973) should be used as a guide. Realignment of the concentrators after an earthquake is acceptable.

h. Lightning. The plant shall be provided with lightning protection. Total destruction of a single module and its controller (RCIA) subjected to a direct lightning strike is acceptable. Damage to a module adjacent to a direct lightning strike shall be minimized within appropriate cost-risk limits. The central controller (MPC) and local controllers (RCIAs) adjacent to a direct lightning strike shall be protected or alternate control methods provided to minimize loss of module control.

i. Noise. Noise emissions resulting from normal operations shall be minimized.

j. Transportability: Sizing and Weight Limitations. System elements shall be designed for transportability within applicable federal and state regulations by highway and railroad carriers using standard transport vehicles and materials-handling equipment. Whenever feasible, components

shall be segmented and packaged to sizes that are transportable under normal, commercial transportation limitations.

k. Safety. The SCSE shall be designed to minimize potential hazards to operating personnel, equipment, and the general public. Safety considerations shall include equipment design and facilities, safety features and warning devices, personnel safety operating procedures, and hazardous materials. Fail-safe shutdown of the plant in the case of grid failure or of the power module in the case of such conditions as engine failure or drive power failure is a design requirement.



## SECTION III

### DEVELOPMENT OF COMPONENTS AND SUBSYSTEMS FOR THE ORC POWER MODULE

A prime driving factor in the design and development of the power module for the Small Community Solar Thermal Power Experiment was its suitability for deployment in a multi-module plant that could produce high quality electric power. Although it had been realized that the first generations of the design would probably not be economically viable in a free market, it was nevertheless determined to make all technical choices and decisions as if they would lead to a commercial, mass-produced plant. Thus, a complete systems approach was adopted, and the importance of the system contractor's role emphasized. The development of the individual components and subsystems was carefully integrated and periodically reviewed so that the objectives and characteristics of the complete plant were not subordinated to those of the constituent elements.

#### A. CONCENTRATOR

##### 1. General Characteristics

The physical characteristics of the concentrator selected for the module can vary widely without affecting the functional performance of the power module or the entire plant, that is, many different sizes and kinds of concentrators would be compatible with the multi-module plant, subject to the provision that the concentrator design meet the environmental requirements, be compatible with the proposed control system with regard to tracking and stowing, and focus the correct quantity of solar energy into a 15-in. aperture with a flux distribution approximately like that reflected from a paraboloid of revolution. Thus, two different concentrators were proposed for the power module at different times in the course of this program.

The first candidate (Figure 3-1a) was the GE-designed PDC-1. This design (for a description, see Reference 3-1) was rejected when studies showed that a cost ceiling and plant performance requirements set by DOE could be met only if the number of modules was limited to four and the power of each module increased from 20 to 25 kWe. In place of PDC-1, FACC proposed a 12.2-m-diameter version of the Acurex-designed dish (Figure 3-1b), which was derived from an advanced concentrator concept designed by Acurex in collaboration with JPL.

The Acurex PDC-2 was selected for use with the SCSE power module on the basis of measurements made on a prototype reflective panel developed under a prior technology development contract between JPL and Acurex. The panel was designed for an 11-m-diameter dish, using structural foam glass as the substrate, to which a thin, back-silvered glass sheet had been cemented. Notwithstanding the difficulty of securing glass panels of sufficient size,

(a)

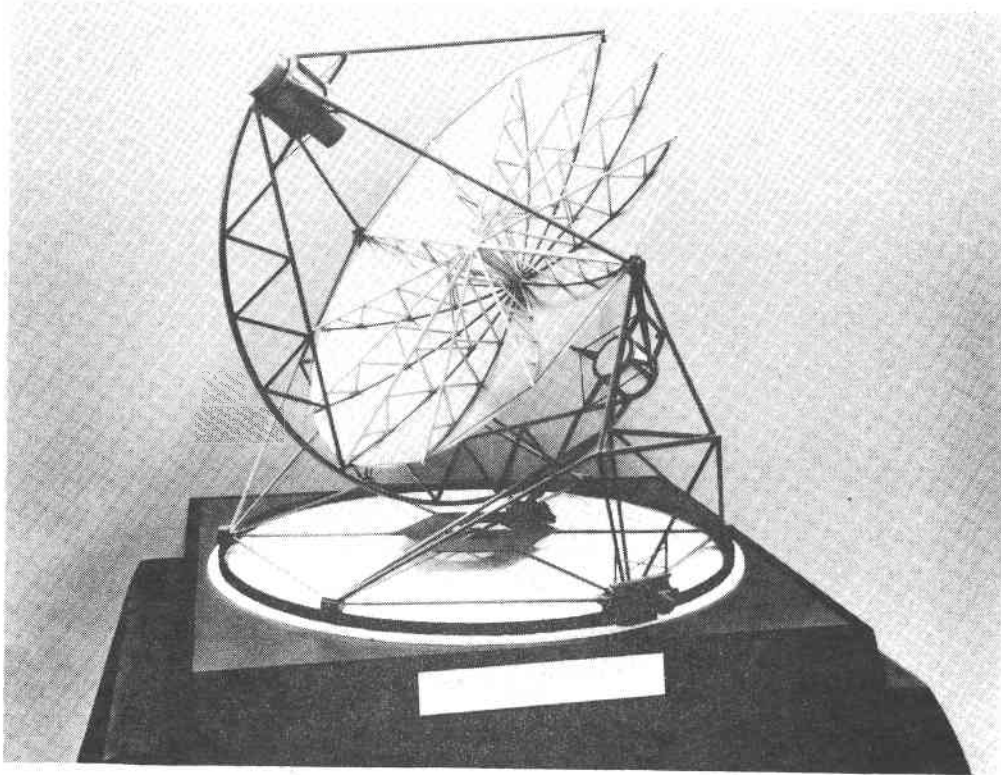

(b)

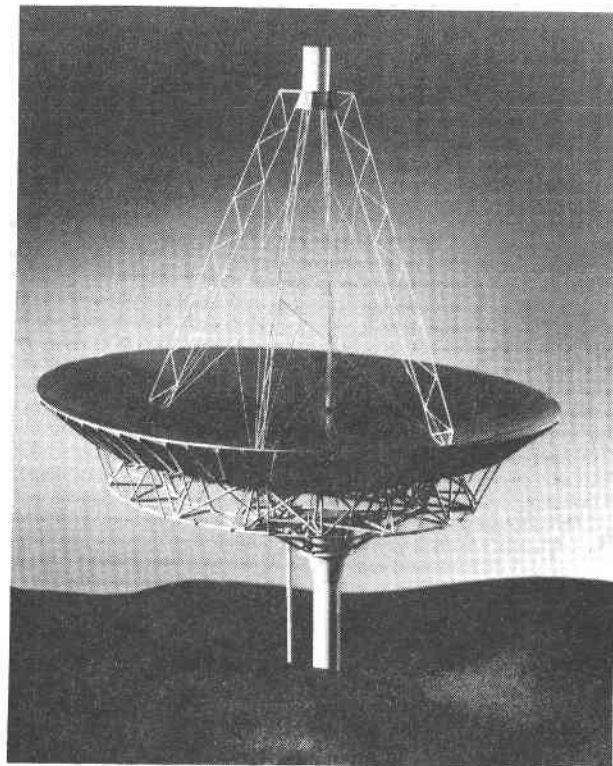

Figure 3-1. Scale Models of Proposed Concentrators (a) General Electric PDC-1 and (b) Acurex PDC-2

FACC, the system contractor, determined that the original 11-m dish could be enlarged to 12.2 m and that four dishes of this size (using 25-kWe power conversion assemblies) could meet the 100-kWe plant rating requirement for the Small Community Solar Thermal Power Experiment. Because of subsequent problems in meeting set cost ceilings, the development of this concentrator did not go much beyond the design stage, and only preliminary test mirror panels and tooling were fabricated. The following paragraphs describe the PDC-2 concentrator, proposed and designed but never built as part of this ORC module development program. These specifications are drawn from the critical item specification, Reference 3-2.

## 2. Parabolic Dish Concentrator No. 2 Subsystem Description

The Parabolic Dish Concentrator No. 2 (PDC-2) is a single-reflection, point-focusing, two-axis tracking solar concentrator with a reflective surface diameter of 12.2 m (See Figure 2-2). The concentrator consists of five subsystems.

a. Reflective Surface. The concentrator surface consists of two concentric rings of independently reflective elements that form a physically discontinuous paraboloidal reflective surface with a common focal point. Twenty-four elements make up the inside ring, and 40 comprise the outside ring. The aperture diameter is 12.2 m with a focal-length-to-aperture-diameter ratio ( $f/D$ ) value of approximately 0.55.

The 64 reflective elements are installed on a ring-link gore support structure with statically determinant, three-point attachments. These attachments have sufficient degrees of freedom to allow fine tuning of the composite surface geometry and differential/thermal displacements.

Each reflective element, or gore (Figure 3-2), is fabricated of thin, back-silvered glass mirror bonded to a contoured substrate of cellular (foam) glass.

b. Support Structures. There are four elements in the support structure subsystem.

Gore Support. The gore support structure is a space-frame ring truss made of structural steel tubing. The ring structure provides the structural interface for:

- (1) The reflective gores.
- (2) The PCA support structure.
- (3) The elevation drive mechanism and bearings on the drive-support structure.

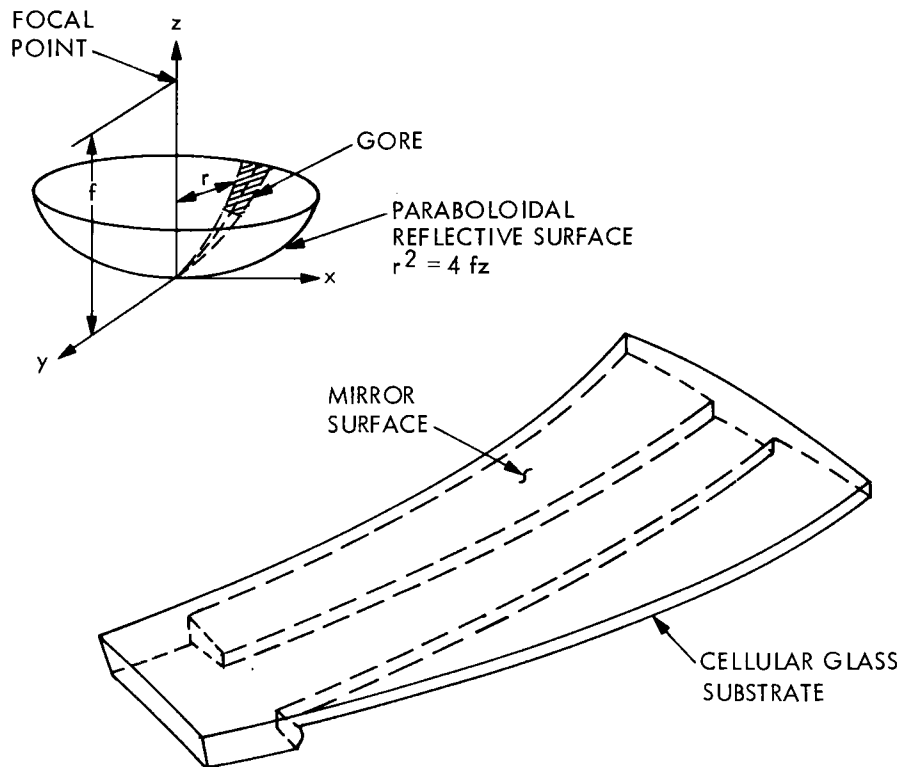

Figure 3-2. Mirrored Cellular Glass Gore

Drive Support. The drive-support structure serves as an intermediate structure between the reflector assembly and the pedestal. It is pivoted about the azimuth axis at the top of the pedestal. Thrust loads are transmitted at that point to the pedestal through thrust bearings. The reflector (dish) is also pivoted, in elevation, about the two upper corners of the drive-support structure. The elevation drive is mounted near the azimuth pivot bearing mount.

Power-Conversion Assembly Support. The support structure for the power-conversion assembly is a quadripod formed from four structural steel truss-style legs and braced with tension elements. The quadripod also provides a means of routing cables and lines to the equipment located at the focal point. The structure is designed to support the PCA at the focal point and is rigidly attached to the gore structure at four points located 45 deg with respect to the vertical and horizontal dish axis. Structural elements are insulated to protect them against heating by the focal spot during a transient passage and steady-state operation.

Pedestal. A cylindrical pedestal structure is constructed of structural steel. It provides a fixed axis about which the concentrator assembly is pivoted. It transmits elevation actuator loads and horizontal wind forces to the foundation. The pedestal provides a minimum of 0.61-m (2-ft) clearance with the ground when the dish is pointed at the horizon and provides a means of supporting cabling/conduit and junction boxes.

c. Drive Subsystem. The concentrator can be driven independently about elevation and azimuth axes at two speeds: slew and tracking.

Azimuth Drive. Azimuth rotation is provided by a ring/gear pinion drive mounted at the top of the pedestal. The pinion is driven by a motor through a gear reduction to provide the necessary mechanical advantage.

Elevation Drive. The elevation rotation is accomplished with a linear actuator mounted between the drive-support structure and gore-support structure. The motor is equipped with a brake to prevent movement when power to the brake is removed.

d. Electrical Instrumentation and Control Subsystems. The electrical subsystem provides power to the concentrator drives and transmits the output power from the PCS to a rectifier box mounted on a rack near the pedestal. Also mounted on the rack are (1) two PDC-2 motor controllers (azimuth and elevation drive) with local (manual) control and electrical disconnect, (2) the RCIA, and (3) boxes used for PCS control (electrical brake, PCS control, fan control, motor starters, and a junction box). All cables are contained in rigid or flexible conduit (or equivalent). Other components in the electrical system include the power to operate the PDC-2 brake, convenience outlets on the concentrator and the rack, and emergency/safety switches.

The control subsystem elements located at the concentrator consist of a sun sensor, azimuth and elevation positional feedback device, and the RCIA. The RCIA contains the control algorithms and logic for providing signals to the motor controllers that provide power to the drive motors. Adverse environmental conditions will be sensed in the Master Power Control (MPC) and signals will be sent to the RCIA to stow the concentrator.

e. Foundation. The foundation support consists of a cylindrical (pipe) pedestal and concrete pier. The pier is a poured-in-place, reinforced concrete cylinder in which the pedestal is embedded.

### 3. Interface Definition

The PDC-2 shall meet the physical and functional interface requirements for the subsystems defined below.

a. PCA Configuration and Weight Estimates. The concentrator is designed to support a 681-kg (1500-lb) PCA that is 1.12 m (44.25 in.) in diameter and 2.33 m (92 in.) in length. The center of mass of the PCA is located 1.05 m (41.2 in.) aft of the receiver aperture.

b. Receiver Aperture. The solar flux produced by the concentrator is delivered to a 37.95-cm (14.94-in.)-diameter receiver aperture located at the focal plane.

c. Focal-Spot Location. The focal spot must be located within the following limits. Panel adjustments shall be available to meet these requirements.

Axially. Aperture plane (focal length) within  $\pm 5$  cm ( $\pm 2$  in.) of the theoretical location.

Radially. Center of the focal spot (beam) within  $\pm 2.5$  cm ( $\pm 1$  in.) of the geometric centerline of the dish.

d. Electrical Drive Power. Electrical power to the motor controllers is 480-V, three-phase power. This power will be delivered via the switchboard. Electrical drive power to operate the brake shall be determined during the design phase.

e. Requirements for Operational Configuration. The following requirements shall be met with the power module in its operational configuration, i.e., with the PCA, cabling, and on-module boxes installed.

Thermal Performance. The primary performance requirement for the concentrator is that it shall supply a minimum of 96.5-kW thermal power through the aperture when the clean reflective surface is illuminated with a direct (normal) solar flux of  $1.0 \text{ kW/m}^2$ . This "rated" condition shall be maintained as the concentrator tracks the sun during normal operation conditions, including wind speeds from zero to 4.5 m/s (10 mph). The goal is to obtain a thermal power through the aperture of 101 kW at rated conditions. This requirement is equivalent to defining a concentrator efficiency requirement as follows:

$$\eta_{\text{conc}} \geq P_c/A_c$$

where

$P_c$  = Concentrator reflected power, kWt at  $1.0 \text{ kW/m}^2$  insolation  
= 96.5 minimum, 101 as a goal

$A_c$  = Aperture area of dish,  $\text{m}^2$  ( $A_c = 116.9 \text{ m}^2$  for 12.2-m diameter)

and

$$\eta_{\text{conc}} = \rho K_b K_D \gamma$$

where

- $\rho$  = hemispherical reflectivity
- $K_b$  = "blockage" coefficient (all losses due to gaps, engine/mounting structure, blockage and shading)
- $K_D$  = dust coefficient = 1.0 (clean surface)
- $\gamma$  = intercept factor at receiver aperture (includes errors due to slope ( $\sigma_s = 3$  mr), pointing ( $\sigma_p = 1.745$  mr), sun source ( $\sigma_{ss} = 2$  mr), and specularity ( $\sigma_{\text{spec}} = 0.2$  mr). Nominal value of  $\gamma = 1.0$ )

Brake. A holding brake shall be provided for the elevation axis that is applied by either control contact "open" or removal of power. The brake shall be capable of holding the elevation drive mechanism stationary under the stow and operating conditions.

Tracking. Tracking may be commanded in either direction of each axis, singly or simultaneously. The concentrator shall then rotate at a rate of 0.11 deg/s until the signal is removed. This speed shall be repeatable with 10% of the selected rate under operating conditions, and the tracking rate shall be adjustable. The tracking error due to all sources (i.e., sensor alignment, wind gusts that occur when the operating wind speed is below 11.2 m/s [25 mph], gravity sag, and controller operation) shall meet the focal-spot location requirements.

Slew. Slew may be commanded in either direction of each axis, independently or simultaneously. The drive speeds for slew will be selected by Acurex but shall not be less than the following: (1) elevation: 1.0 deg/s and (2) azimuth: 1.0 deg/s.

Zero Speed. The maximum rate bias of the controller when zero speed is commanded shall be less than  $\pm 0.01$  deg/s.

Speed. In addition to the track and slew speeds, a "stop" or zero speed shall be available. During "stop" the power consumed by the concentrator drive components shall be minimized, consistent with cost and reliability considerations.

Acceleration/Deceleration. Acceleration from a stop should be greater than  $1 \text{ deg/s}^2$ . Deceleration when stopping from slew speed should be greater than  $1 \text{ deg/s}^2$  and shall be repeatable so that the angle traversed during the deceleration to zero speed is predictable to within  $\pm 0.1 \text{ deg}$  of the nominal value.

Method of Control. The concentrator shall be designed so that the implementation of control techniques will allow the concentrator to: (1) maintain sun track within the defined accuracy by use of a sun sensor, (2) follow the sun's path while behind clouds (ephemeris track using the predicted position calculated by the RCIA), (3) do an offset track using ephemeris prediction, (4) be commanded to other positions including stow, and (5) satisfactorily make the transition on and off sun track (acquisition and detrack from sun). Local controls for each axis shall be provided near the concentrator. These controls shall allow operations independently of the RCIA.

Focal-Spot Location. Any radial offset in the normal location of the focal spot shall not exceed  $0.1 \text{ deg}$  during sun track in wind speeds up to  $4.5 \text{ m/s}$  ( $10 \text{ mph}$ ). The offset at winds up to the operational limit of  $11.2 \text{ m/s}$  ( $25 \text{ mph}$ ) shall result in no face-plate damage.

#### 4. Operational Criteria

a. Travel. The range of travel for the two axes shall be as follows: The concentrator shall have the capability of pointing due north ( $0 \text{ deg}$ ) in azimuth (Az) for the purpose of resolver (encoder) calibration, maintenance of the PCA, and dish maintenance and cleaning. Azimuth travel for solar acquisition and tracking shall be from  $0$  (North) to  $310 \text{ deg}$ . Travel is not required in the segment for  $310$  to  $360 \text{ deg}$  in azimuth.

The range of elevation (El) travel shall be a minimum of  $0$  to  $90 \text{ deg}$ , where  $0 \text{ deg}$  is horizontal.

The maximum range of elevation angles for operation of the PCA shall be from  $5\text{-deg}$  elevation in the morning until  $5\text{-deg}$  elevation before sunset.

b. Stow. The high-wind stowage position shall be toward the zenith (straight up). This shall also be the stow position used for normal nighttime and cloudy weather conditions. An optional stow condition for nighttime and daytime conditions shall be the maintenance position.

c. Maintenance. During maintenance, the concentrator shall be pointed due north at  $0\text{-deg}$  elevation.



## 5. Environmental Conditions

### a. Wind

Operational. The concentrator shall operate safely without damage to the receiver face plate or other components in wind speeds up to 11.2 m/s (25 mph). The concentrator shall meet the performance requirements specified for wind velocities (speeds) up to 4.5 m/s (10 mph) in any direction. Degradation in slope and pointing errors for wind speeds up to the operational limit shall be consistent with the focal-spot requirements previously given.

Wind gusts may occur at any time; these gusts are superimposed on the average wind-speed requirements defined herein. An increase in wind velocity to 20.7 m/s (46.2 mph) during a 2-s duration (2-s triangular pulse with a base wind speed of 11.2 m/s [25 mph]) shall cause no structural damage with the concentrator in any position.

Slew to Stow. The concentrator will be commanded to initiate a slew to the stow position when the wind reaches an average velocity of 11.2 m/s (25 mph) from any direction. The wind will be measured 10 m (33 ft) above ground level, using the weather-station anemometer. The concentrator shall survive slew-to-stow without damage from any initial orientation. Typical wind rise rates of  $0.01 \text{ m/s}^2$  (1.3 mph/min) shall be used as a guide for estimating wind loads during stowage. The wind gust defined above shall also be considered.

Stow position. The concentrator shall survive "fastest mile" wind speeds of 35.8 m/s (80 mph) from any direction. At this wind speed, less than 5% of the reflective panels shall have cracks or other types of failure after a total cumulative time of 6 h. If cracks occur, this shall not cause the panels to fall from their supports. A 2-s wind gust of 42.5 m/s (95 mph) from a base speed of 35.8 m/s (80 mph) shall be survived with no structural damage.

### b. Temperature

Operating. The concentrator shall be safely operable within the ambient temperature range of  $-10^{\circ}\text{C}$  ( $15^{\circ}\text{F}$ ) to  $46^{\circ}\text{C}$  ( $115^{\circ}\text{F}$ ) and meet the performance requirements within the temperature range of  $0^{\circ}\text{C}$  ( $32^{\circ}\text{F}$ ) to  $40.5^{\circ}\text{C}$  ( $105^{\circ}\text{F}$ ).

Storage. The concentrator shall withstand without damage repeated exposure to ambient temperatures ranging from  $-26^{\circ}\text{C}$  ( $-15^{\circ}\text{F}$ ) to  $50^{\circ}\text{C}$  ( $122^{\circ}\text{F}$ ) and relative humidity up to 100%.

c. Seismic. The power module (concentrator/PCA/etc.) shall survive a lateral acceleration of 0.25 g in any direction, combined with a vertical load of 1.17 g due to gravity and seismic acceleration. No damage

shall be experienced when subjected to this loading with the concentrator in any position. Realignment of the concentrators after an earthquake is acceptable.

## 6. Other Environments

The concentrator shall survive without damage and operate properly after withstanding the following environments and reasonable combination of environments.

### a. Precipitation

Hail. 1.9 cm (3/4 in.) in diameter, a specific gravity of 0.9 at 23 m/s (51 mph) and at any orientation of the concentrator.

Rain. 7.5 cm (3 in.) within a 24-h period, annual average of 86 cm (33.7 in.)

Snow and ice accumulation. 250 Pa (5 lb/ft<sup>2</sup>).

Freezing and Thawing. Repetitive throughout life of concentrator for relative humidity up to 100%.

b. Blowing Sand and Dust. Equivalent to conditions of PDTS or Osage City, whichever is more severe.

c. Lightning. The concentrator shall have lightning protection devices to minimize the damage caused by a direct lightning strike.

d. Birds. The reflector shall be resistant to bird droppings and be readily cleaned. Nooks and crannies that can be used by birds for nesting or roosts shall be minimized.

e. Vandals. The concentrator shall be as resistant as practical to damage by vandals.

## 7. Inspection and Maintenance

Maintainability shall be considered in the design and operation of all components of the concentrator to ensure minimum cost for maintenance over the plant life and downtimes, consistent with reliability and availability requirements.

## 8. Mirrors

The following are specifications and requirements for the reflective panels:

- a. Gore Material. Each reflective-element gore shall be designed to incorporate a back-silvered glass mirror surface, bonded to a contoured substrate of cellular glass.
- b. Back-Silvered Glass Mirror (Wet Chemical Silvering Process). Glass type is Sodalime (chemically strengthened), drawn glass, or equivalent.
- c. Slope Errors. The nominal rms (root mean square) slope error of the reflective panels mounted on the concentrator shall not exceed 3.0 mrad, including fabrication, gravity loads, thermal gradients, panel alignment, support-structure gravity loads, and loading from a wind of 4.5 m/s (10 mph). The value for the overall slope error shall be consistent with the requirements listed previously.
- d. Reflectance and Specularity. The average total hemispherical reflectance of the mirror surface over the solar spectrum shall be 0.92 (0.95 as a goal). The final value shall be consistent with the performance requirements. The nominal specularity shall be 0.2 mrad (1) or less.

9. Overall Characteristics. A summary of the characteristics of the PDC-2 concentrator is shown in Table 3-1.

## B. THE POWER-CONVERSION ASSEMBLY

The circumstances that attended the engine studies and the rationale employed in the selection of the organic Rankine-cycle engine have been mentioned in Section I. In addition to those general considerations, the attributes that resulted in the specific Barber-Nichols design were determined by the following requirements for the overall plant:

- (1) The plant and its components should have an economic life of 20 to 30 yr. To meet this requirement, the engine cannot be of the reciprocating piston type unless maintenance and repair costs are brought down to a very low level. Only turbines running on hydrodynamic or gasdynamic bearings promised this capability. On the other hand, existing steam turbines in this size range, although demonstrating satisfactory longevity, are known to operate at very low efficiency.

Table 3-1. PDC-2 Summary<sup>a</sup>

Parameter	Design Summary
Physical Characteristics	<p>Diameter = 12.2 m (40.03 ft)</p> <p>Aperture area = 116.9 m<sup>2</sup></p> <p>Weight capability at focal plane = 680 kg (1500 lb) for PCA</p> <p>Geometric concentration ratio (FACC aperture) = 1000</p> <p>f/D = 0.55 (= 45-deg rim angle)</p>
Optical Performance	<p>Shadowing (<math>K_b</math>) = 0.897, minimum, 0.91 goal</p> <p>Reflectivity (<math>\sigma</math>) = 0.92, minimum, 0.95 as a goal</p> <p>Slope error = 3 mrad, 1</p>
Tracking and Operation	<p>Computer coarse track within <math>\pm 1^\circ</math> (during clouds, etc.)</p> <p>Fine track accuracy within 1.745 mrad, 1.</p> <p>Automatic acquisition and stow; morning and evening</p> <p>Track rate - adjustable, 0.1 deg/s nominal</p> <p>Slew rate = 1 deg/s</p> <p>Normal stow at zenith (straight up)</p> <p>Max. wind speed for operation within spec. = 4.5 m/s (10 mph).</p> <p>Max. wind speed for operation = 11.2 m/s (25 mph).</p>

<sup>a</sup>Type: Elevation-over-azimuth with single post mount.

- (2) Experimental risk should be kept to a minimum. Metallurgical problems associated with high temperatures were avoided by selecting a working fluid temperature of 750°F,<sup>5</sup> but even at this modest temperature there was some concern that the toluene might decompose and form secondary compounds that could interfere with the long-term operation of the engine. Laboratory experiments (Reference 3-3) indicated that acceptable freedom from decomposition can be realized, even at temperatures above 850°F, if the toluene is not allowed to come into contact with air, water, or a variety of other common materials. Careful attention was thus given to the selection of materials, and a hermetically sealed design was adopted. For the purpose of this project a hermetic design is one in which no moving seals are employed, and where static seals are designed and tested to ensure that the leakage rate is below the threshold of detectability, using standard industrial instruments. It was expected that commercial versions of the design would employ welded joints and seams wherever possible.
- (3) The system must provide power of a high quality with no risk of dynamic interaction between the individual modules or between the plant and the distribution grid. Although only a single module was developed, fabricated, and tested in this project, the integrity of the plant design was always uppermost; no technology was selected, nor any decision made that might have subsequent negative repercussions when the modules were called upon to operate in parallel in a user environment. Thus the alternator, the control system, and the energy transport system were designed "from the top down." The outcome of this approach to the design of the module components was the selection of a directly-coupled, permanent magnet alternator producing a high-frequency, three-phase alternating current. An efficient rectifier tied directly to each alternator then changed the alternating current output to direct current so that the outputs of each module could be connected in parallel and fed to a central inverter.

1. Description of the Power-Conversion Assembly (Reference 3-4)

The Power-Conversion Assembly (PCA) of the ORC power module consists of a receiver and the Power-Conversion Subsystem (PCS), or engine. The PCS, in turn, is made up of a turbine/alternator/pump (TAP) assembly, a regenerator, condenser, cooling fan, and a network of pipes, valves, and controls (Figure 3-3).

---

<sup>5</sup>A later proposal by FACC called for raising this to 800°F to increase the plant rated output.

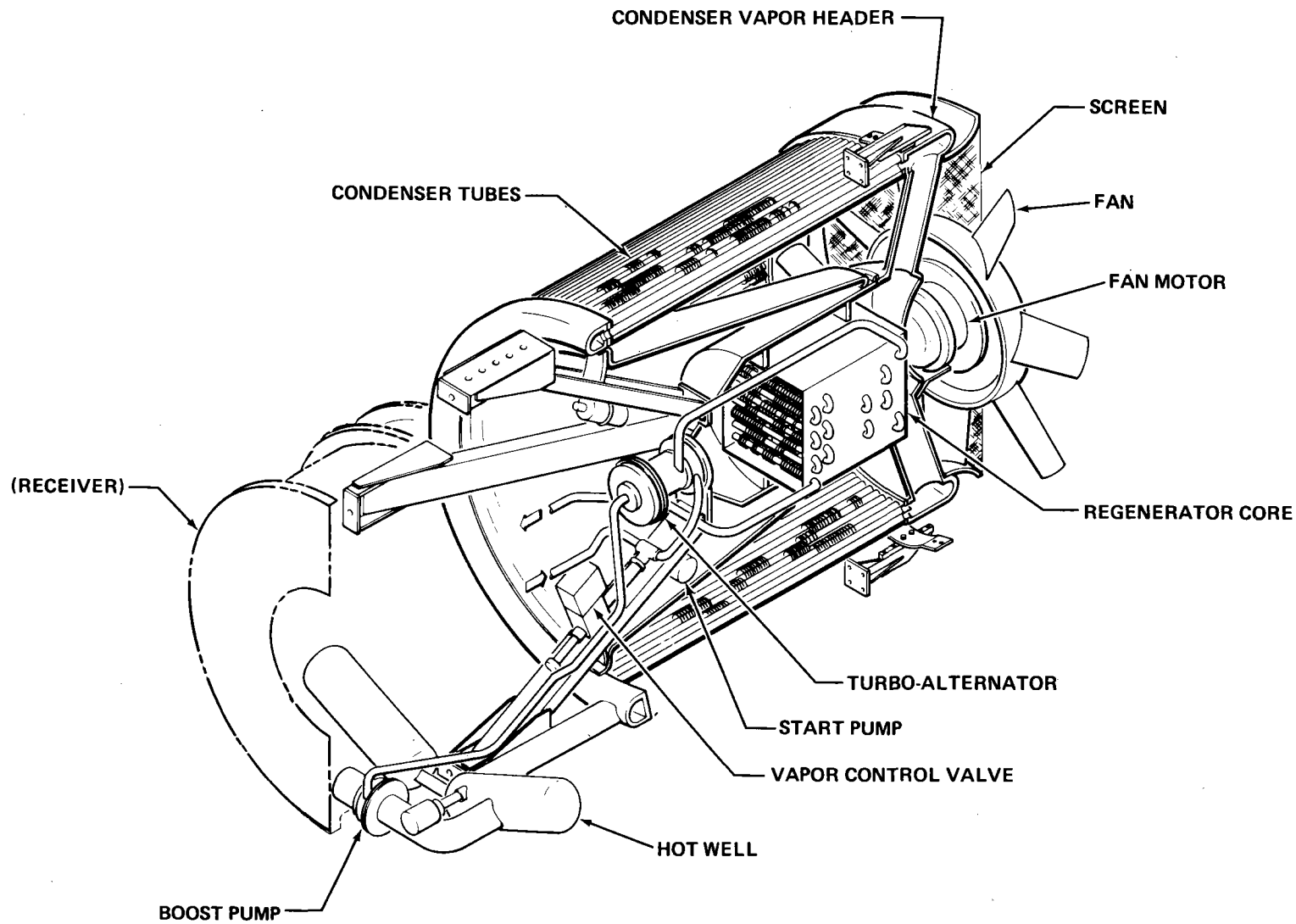

Figure 3-3. Power-Conversion Subsystem

The thermodynamic cycle used in this power-conversion subsystem and the physical implementation of the cycle in the module can best be understood by an examination and comparison of Figures 3-4 and 3-5. The path of the working fluid as it traverses the state points of the circuit (See Figure 3-4) is designated by circled numbers that correspond to those on the pressure-enthalpy diagram (See Figure 3-5).

Several interesting features can be pointed out in Figures 3-4 and 3-5.

- (1) The pressure-enthalpy diagram for toluene (Figure 3-5) exhibits a drying characteristic upon expansion (points 2 to 3). This property is desirable in that there is no problem with entrained liquid particles impinging on the turbine wheel. On the other hand, for higher efficiency, a regenerator is required (points 3 to 4) to extract heat from the superheated vapor and transfer it to the liquid before it is returned to the receiver.
- (2) As depicted in the diagram, the toluene is in the super-critical regime during its passage through the receiver at higher power levels. This mode of operation was originally adopted because it avoided the potential risk of boiling instability in the receiver, although at a slight cost of efficiency. It was discovered during receiver qualification tests that the boiler behavior was exemplary in this regard; therefore, the selected state points were altered to permit operation in the sub-critical range at the lower power loads.
- (3) The peak temperature to which the toluene is subjected is 750°F. It had been determined on the basis of laboratory tests that pure toluene (not exposed to air, water, or certain materials) can be operated for several years without expectation of decomposition. The record of performance in actual engines is not so clear because the operating conditions in engines have never been exactly defined, unlike the laboratory tests. The actual lifetime of the working fluid was to have been a discovery of the experiment, and the systems were designed for convenient draining and refilling of the toluene to permit analysis and as a maintenance procedure.
- (4) The toluene working fluid is used to cool the TAP assembly by circulating liquid toluene through a cooling jacket surrounding the stator windings. This has the effect of recycling some of the energy normally lost as heat due to friction, turbulence, and electrical losses.

## 2. Receiver

The receiver was initially regarded as a high-risk development item, and every attempt was made to find a scheme that would be compatible with a cylindrical cavity configuration and that would subject the toluene working fluid to temperatures no higher than those it encountered at the turbine inlet valve. Low parasitic pumping losses and some short-term thermal

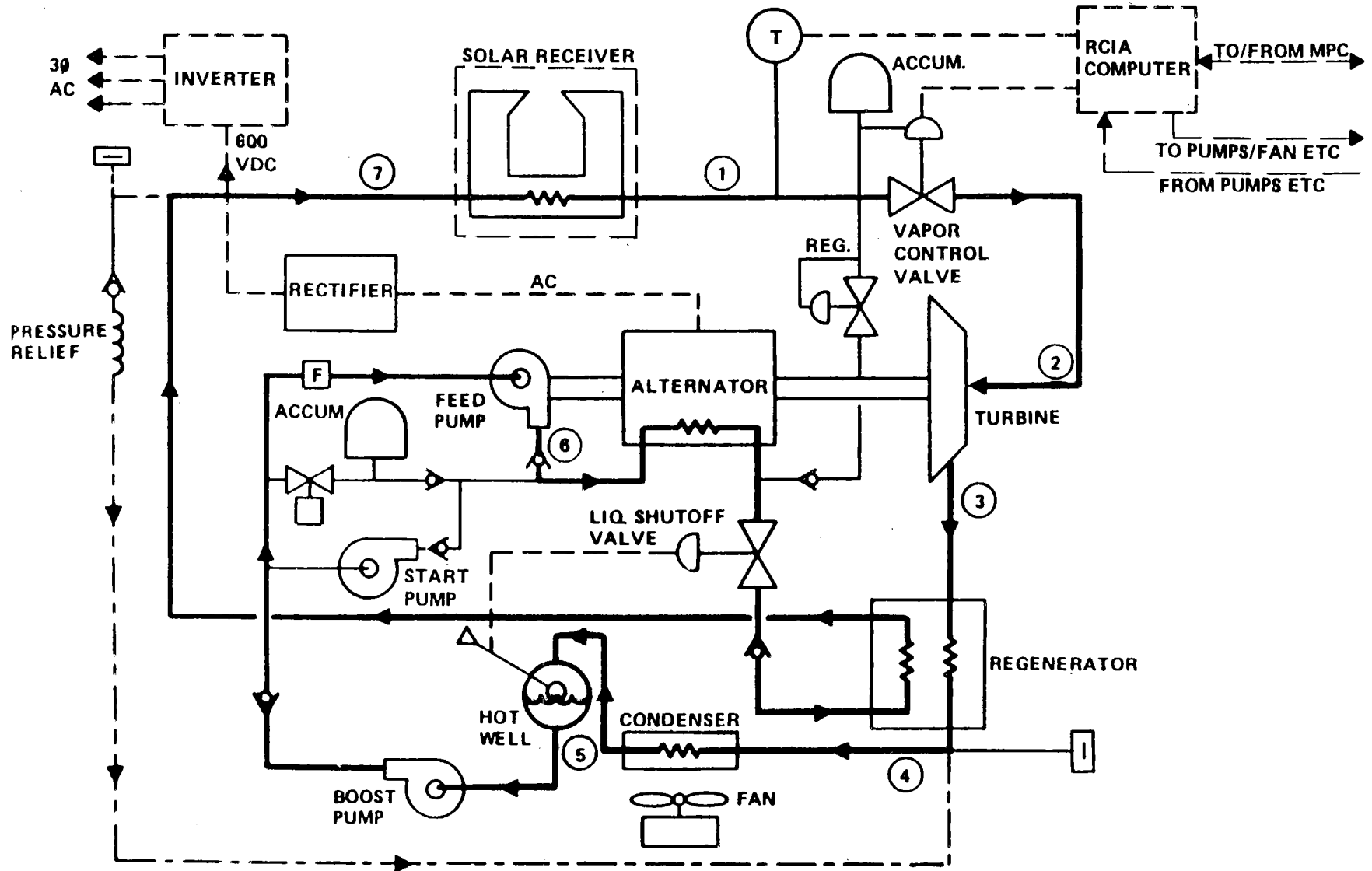

Figure 3-4. Schematic Diagram of ORC Power-Conversion Assembly. See Figure 3-5 for Temperature, Pressure, and Enthalpy of Working Fluid at Positions Identified by Circled Numbers.



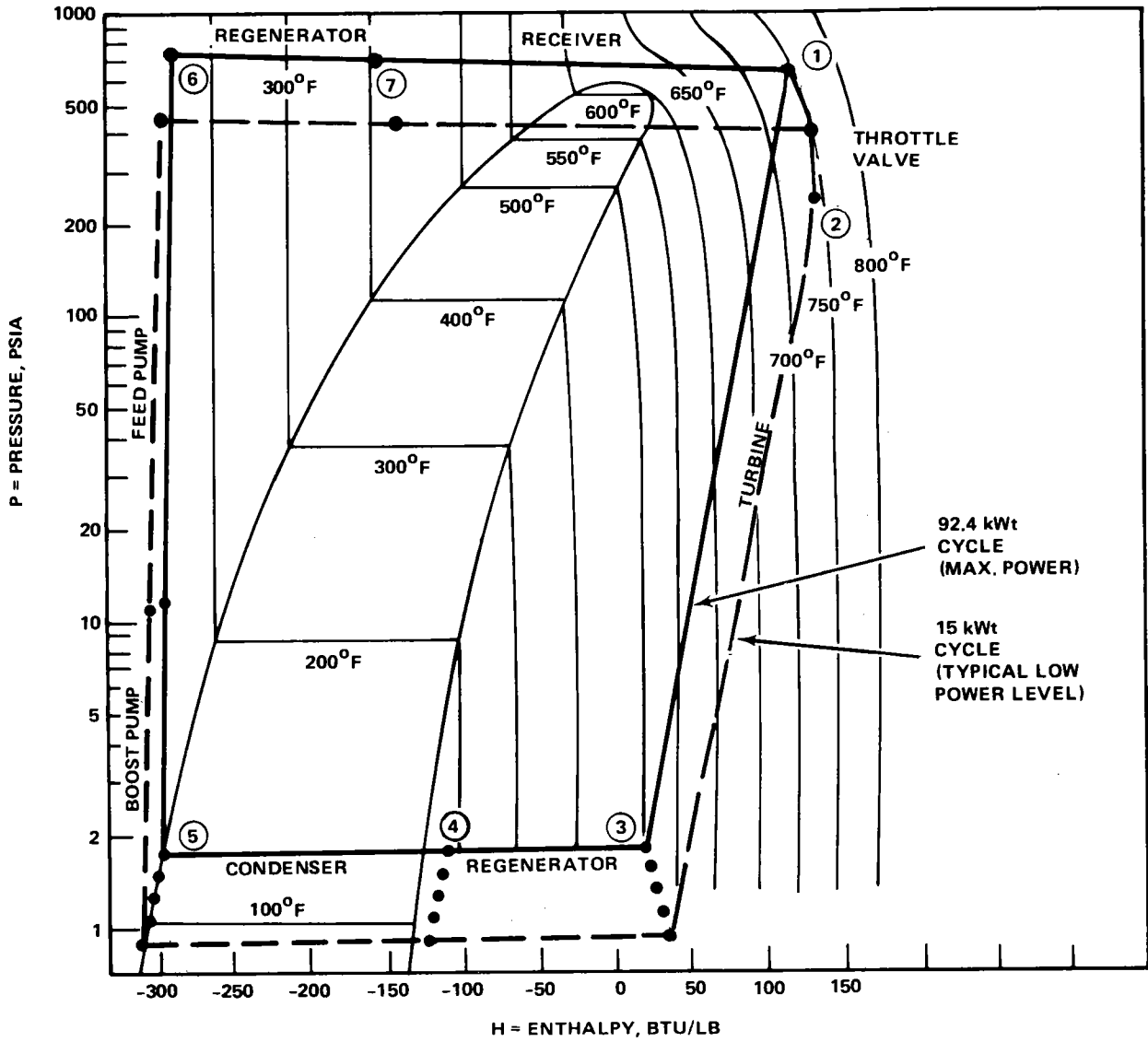

Figure 3-5. Diagram of Pressure/Enthalpy for the Organic Rankine Cycle. Numbers Designating State Points Correspond to Numbers in Figure 3-4

storage were also regarded as desirable attributes for a successful design. Many concepts were considered, including using liquid (non-boiling) sodium as a heat-transfer fluid, terphenol in a pool-boiling mode, and various intermediate heat-transfer media, including molten salts and silicone-based fluids. In the end, analysis showed that a single stainless steel tube, brazed to the exterior of a copper cylindrical shell, directly heated, could be expected to perform satisfactorily without encountering boiling instability and without scorching the toluene. To secure an additional margin of safety with regard to possible flow instabilities, it was decided to operate the receiver above the critical region for toluene even though calculations had shown that a small penalty in efficiency would result. Test results prompted a change to sub-critical operation when the difficulties were shown to be nonexistent.

The receiver (Figure 3-6) consists of a core assembly, support structure, insulation, outer case, and a copper aperture plate. The core comprises a cylindrical cavity 0.61 m (24 in.) in diameter by 0.48 m (19 in.) deep. Helical grooves machined into the outer surface of both the cylinder and the flat backwall receive the single-pass boiler tubing. Stainless steel tubing 1.59 cm (0.625 in.) outside diameter and 0.89 mm (0.035 in.) wall thickness was laid into the grooves, then brazed to it to ensure good thermal contact. Careful consideration had been given to the choice of materials to ensure freedom from reaction between the toluene and the tubing and to ensure a correct match between the thermal expansion coefficients of the brazing material with that of the shell and the tubing. The entire assembly was plated (using an electroless nickel process) to eliminate the possibility of corrosion. A detailed description of the materials and of the fabrication process is given in References 3-5 and 3-6.

A test loop was constructed at FACC to verify the analysis used in the design of the receiver. This loop permitted the receiver to function as if it were part of the power-conversion subsystem while permitting detailed measurements of temperatures, pressure drop, flow rate, etc. to be performed under controlled operating conditions. During these tests it became apparent that the receiver exceeded all requirements. The Development Test Report (Reference 3-7) and the Receiver Qualification Test Report (Reference 3-8) provided the following summary:

- (1) The predicted efficiency of the receiver was 97.2%, the same value as previously determined from the development tests.
- (2) The measured pressure drop through the receiver core was 38 psi at maximum flow conditions, considerably less than the allowable maximum of 65 psi.
- (3) The measured receiver core temperature profiles were essentially identical to those predicted by analysis and by those measured in the development tests.
- (4) The toluene outlet temperature was easily controlled, stable, and well-behaved.

Test results also indicated that the receiver was able to operate throughout the subcritical range consistent with the requirements of the Barber-Nichols

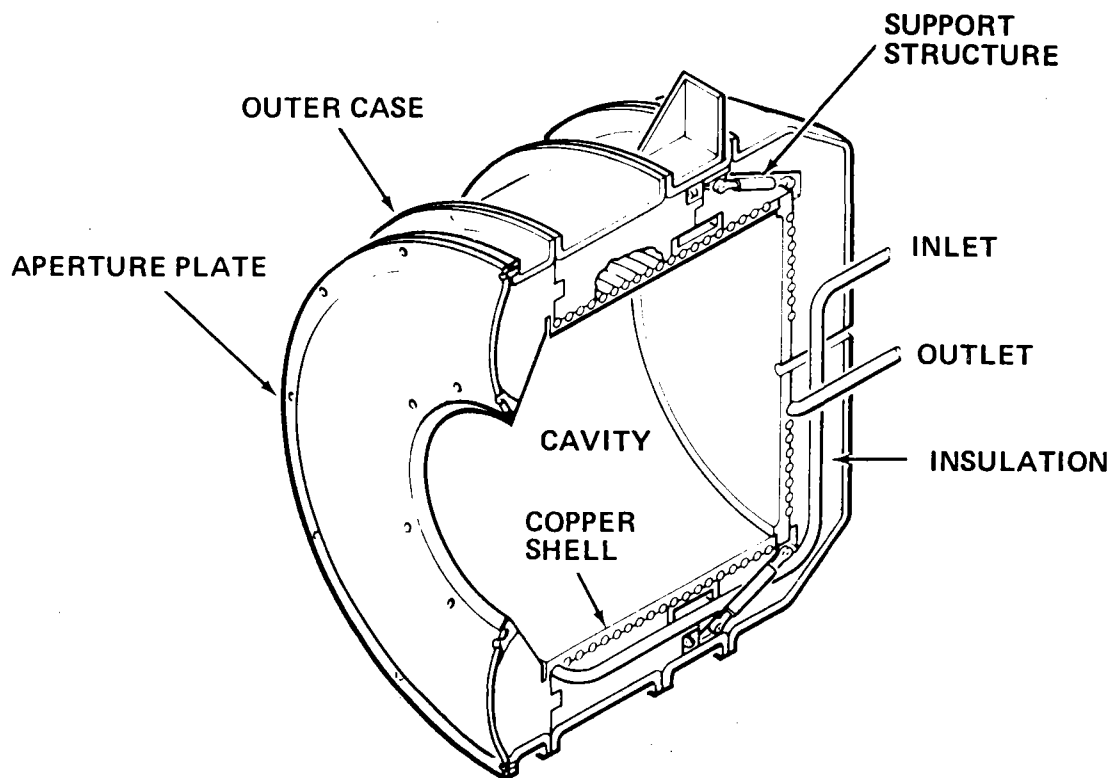

Figure 3-6. Cut-Away View of Receiver Assembly

power-conversion subsystem. (Subcritical conditions result when the unit is operated at lower TAP speed and at low to moderate power levels).

No design deficiencies were found, and it was concluded that the basic receiver design meets or exceeds all of the performance requirements for the SCSE application and is a very "forgiving" design. This is primarily due to the large amount of copper, which acts as "buffer" storage for thermal energy and which eliminates potential hot spots by making use of lateral and axial heat conduction.

### 3. The Power-Conversion Subsystem

Although the general operating requirements had been specified prior to the design of the PCS, it was recognized that the actual values of some of the operating parameters might be changed to optimize the overall unit as operating experience was obtained. Table 3-2 provides a summary of the characteristics of the PCS as they were proposed for what was to be the "final" version to be employed in the multi-module plant. This module was designed for a 95 kWt input and an electrical output of almost 30 kWe, considerably more than was planned for or achieved with the actual PCS fabricated and tested for this program. More detailed descriptions and specifications of the PCS can be found in References 3-3, 3-9, and 3-10.

Table 3-2. Power-Conversion Subsystem<sup>a</sup> Characteristics and Specification Summary

---

GENERAL

---

Toluene working fluid (C<sub>6</sub>H<sub>5</sub>CH<sub>3</sub>, also called methylbenzene)

Hermetically sealed system with integral electrical alternator (ac-dc-ac system<sup>b</sup>)

Operates at all solar-related elevation angles (5 to 90 deg)

Uses forced air-cooled condenser

All components mounted at focal point except for rectifier, brake-control circuitry, PCS control box, and motor starters

---

FUNCTIONAL

---

Rated power: 29.4 kWe (dc) output at 97.4 kWt input

Peak power: 32 kWe (dc) output at 107 kWt input

Net gross efficiency - goal (heat in/electricity out): 30.2% at rated conditions (800°F turbine inlet temperature and 32°F ambient) (See Table 2-1).

Maximum weight: 430 kg (950 lb) for equipment mounted at focal point

Diameter = 1.124 m (44.25 in.)

Toluene turbine inlet temperature range (typical) = 385 to 427°C (725 to 800°F)

---

<sup>a</sup>25-kWe module.

<sup>b</sup>The final ac conversion is accomplished by using a central inverter(s) that is not part of the PCS.

---

Within the power-conversion subsystem the TAP assembly can be regarded as the key element. It was concluded that an efficient, lightweight, long-lived PCS (which could someday be produced at low cost) would require a design that pushes the state of the art in its use of sophisticated technologies and exotic materials. A case in point is the three-phase, permanent magnet alternator using magnets made from samarium cobalt. The use of this material permits the alternator to be very small, and thus capable of withstanding the rotational speeds of 60,000 rev/min. At the same time, a clever design of the PCS control system obviates the need for complex or inefficient speed controls by matching the electrical characteristics of the alternator armature windings (stator) to the constant input voltage capability of the inverter control logic. This allows the turbine inlet temperature to be held at a constant, optimum value.

Similarly, the decision to use hydrodynamically lubricated tilting pad bearings, cooled and lubricated by the toluene working fluid itself, was made to attain long life and freedom from shaft dynamics problems.

A simplified cutaway drawing of the TAP unit is shown in Figure 3-7. The relationship of the TAP to the entire circuit can be seen in Figure 3-4. Starting at the exit from the boost pump, the toluene is piped to the feed pump attached to the near end of the turbine-alternator shaft where an inducer leads the toluene to the partial emission centrifugal feed pump. This single-stage pump raises the pressure of the toluene to approximately 550 psi and circulates it through a helical cooling passage surrounding the stator winding, out of the housing, through the regenerator and then to the receiver, where the toluene is heated and vaporized. The superheated toluene vapor then passes through the vapor control valve, which has been programmed to throttle the flow of the toluene to maintain a nearly constant turbine inlet temperature of 750°F (800°F in the proposed Phase III version). As previously mentioned, the turbine speed varies over a small range as the passive electrical characteristics of the alternator interact with the inverter control, which maintains a constant input voltage across the dc line coming from the module rectifiers. The toluene vapor is discharged through 10 supersonic nozzles equally spaced around the circumference of the turbine housing. One hundred ten symmetrical impulse blades convert the momentum of the vapor into the torque, which drives the 5-in.-diameter turbine. The shaft that connects the pump and turbine also supports the collar carrying the samarium-cobalt magnets that are distributed around it and held in place by bands of Inconel 718.

The radial bearings in the TAP employ toluene-lubricated tilting pads. This type of bearing was selected for its high stiffness and excellent damping characteristics, qualities which tend to reduce susceptibility of the rotating shaft to dynamic instability. In spite of this choice, excessive bearing wear was a serious, persistent problem during much of the development program. To address the problem a special test apparatus was built, materials investigations were undertaken, and extensive dynamic measurements and analyses were performed. A thorough treatment of this bearing development program is presented in Reference 3-11. The configuration that demonstrated freedom from dynamic problems and from wear consisted of a five-pad bearing built by the Waukesha Company. Observations made during the test program

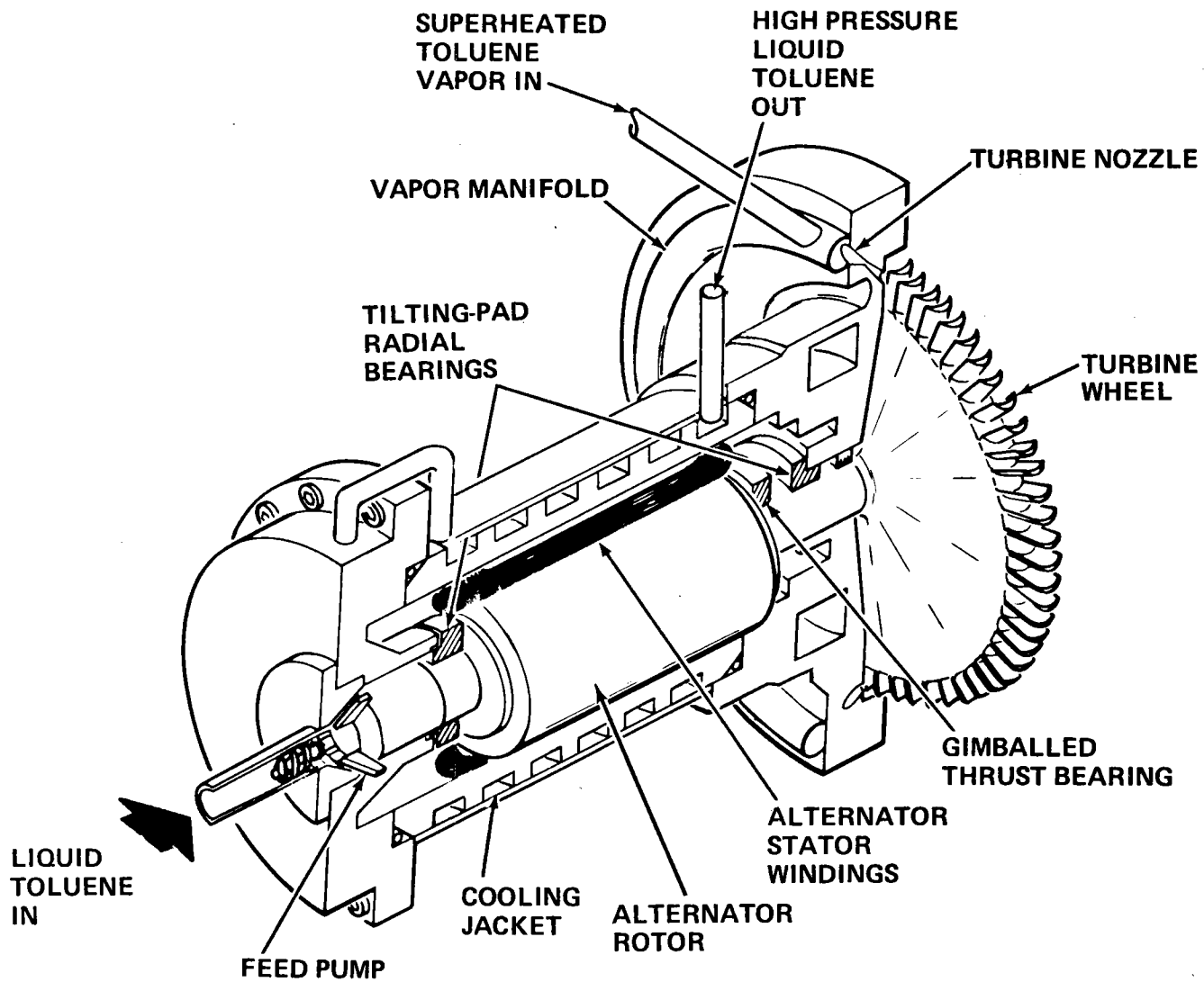

Figure 3-7. Turbine/Alternator/Pump (TAP) Assembly

indicated that even after solving the observed dynamics problems, rapid wear was still taking place and causing early failure of the radial bearings. The cause of this bearing distress was discovered by FACC personnel while photographing and analyzing the bearing parts with a scanning electron microscope. Using X-ray energy-dispersion techniques, they detected the presence of zinc in the bearing pads (where none existed in the original material); thus it was concluded that the contamination was due to electrical arcing between the rotating shaft, the bearing shoes, and an adjacent brass fluid-retention ring. This problem was solved by insulating the bearings with carrier bushings made of glass-filled insulating plastic material. The detailed mechanism that accounts for the generation of this electrical current is not well understood in this specific unit, but installing the insulating bushings did solve the problem to the extent that no bearing wear was measurable after more than 300 h of subsequent operation. A shaft grounding contact had originally been installed for static discharge although it is not known if this component was necessary.

Problems had also been encountered with the axial, gimbal-mounted, thrust bearing, and many tests and modifications were also performed on these bearings. However, it is not unlikely that the problems were induced by radial bearing failures. A Babbitt metal-coated, Rayleigh-step configuration was employed for the turbine end-thrust bearing, while a simpler, radially grooved, gimballed, bronze flat-washer was retained at the pump end. It is likely that the original bronze flat-washer type of thrust bearing was satisfactory, but that excessive wear had been induced through dynamic shaft whirl or improper lubrication during earlier tests. All bearings in the final design, radial as well as axial thrust, were externally fed and fully flooded with toluene.

The alternator consists of the rotating permanent magnet assembly with a stationary, copper-wound, laminated nine-tooth stator.<sup>6</sup> At the design rotational speed of 60,000 rev/min this unit was designed to produce a 3-kHz, three-phase alternating current output between 500 to 600 V. Although not mounted near the focus of the dish, a directly coupled rectifier is considered to be part of the PCS. It changes the ac into dc so the outputs of many modules can simply be connected in parallel without need for synchronization. The combined output is subsequently inverted to 60-Hz power for distribution.

One of the key requirements in the design of the Small Community Plant was that the individual power modules should be able to operate efficiently even though some or all of the modules were in partial shade or producing less than rated power (Reference 3-12). To achieve this capability it is necessary that each module be operated independently at the same maximum allowable turbine inlet temperature, regardless of the heat input to the engine. Thus the primary control parameter, given the variability of insolation, is the mass flow rate of the working fluid. By regulating this flow with the

---

<sup>6</sup>After the test series on the test bed concentrator, the alternator was redesigned to achieve higher efficiencies. Although detailed measurements were not made, it seems that the peak efficiency remained at about 90%, 5% less than the predicted design value.

throttle valve, the turbine inlet temperature can be controlled and kept at a predetermined, measured value. On the other hand, examination of Figure 3-8 shows that the locus of optimum operating points is a line, near-vertical, gently curving upward and to the right. If the internal impedance of the various alternators is fixed at the correct predetermined value, and the bus that connects the rectified output of these alternators is controlled by the logic of the single inverter to maintain a set input emf (e.g., 600 V), then the voltage drop through each armature (stator) will exactly cancel out the increment in generated voltage at the higher power output resulting from the higher speed (Figure 3-9).

It remains only to match the optimum operating line with the alternator power output line (being fed into the load) to arrive at a near-optimum operating condition for varying thermal inputs. This system requires a "smart" inverter that maintains the pre-set voltage across the dc input bus regardless of variations in conditions downstream, i.e., in the distribution grid. This is achieved by varying the duty cycle within the inverter.

The pump employed in the TAP unit is a partial-emission, centrifugal pump with radial blades and an integral inducer that extends into the supply line carrying the liquid toluene to the feed pump. The axial pressure forces on the pump were kept small by employing a small-diameter impeller disc, thus requiring the impeller blades to be cantilevered beyond the disc. Figure 3-10 shows a cross-section view of the TAP assembly in which the relative sizes and locations of the various parts are illustrated.

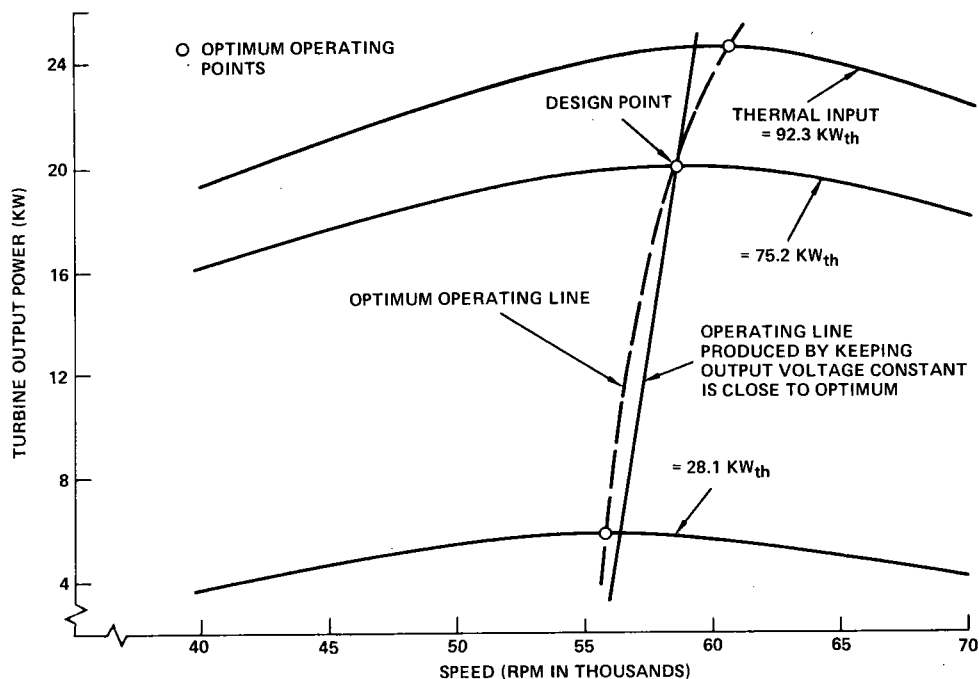

Figure 3-8. Relationship Between Turbine Power Output and Speed for Various Thermal Inputs.



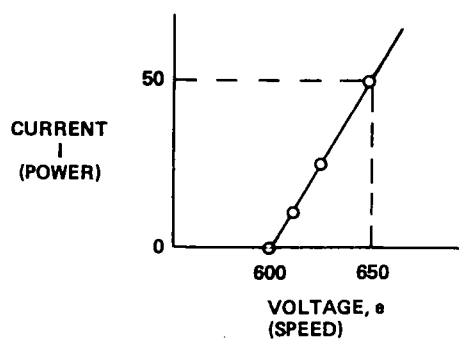
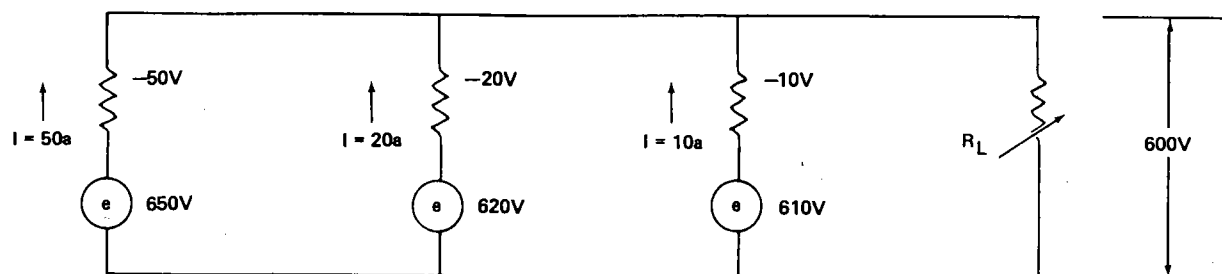

Figure 3-9. Effect of Variations in Current (or Power) Output for Alternators with Predetermined Internal Impedance Feeding a Variable Load that Maintains a Constant (600-V) Voltage Across Its Input.

#### C. ENERGY TRANSPORT SUBSYSTEM

The Energy Transport Subsystem (ETS) comprises that part of the power module or of the plant that carries the electricity generated at each module to the central collection point, then to the local utility grid (See Figure 2-1). The ETS consists of the following components:

- (1) Electrical power cables.
- (2) Switchboard.
- (3) Control inverter(s).
- (4) Load bank(s).
- (5) Grid interface equipment.

The key element in the ETS is the inverter: it plays a critical role in the control of the individual modules and of the entire plant. It is also important because its efficiency has a direct bearing on the efficiency of the plant. This factor suggests that a multi-module plant should employ a single, large inverter to handle the output of all the modules because machines of this type are more efficient when their capacity is large. On the other hand, the efficiency of a specific inverter usually decreases at partial load, and it may be advantageous to interchange several inverters so that each accepts the electrical output from several modules and operates at near-peak efficiency.

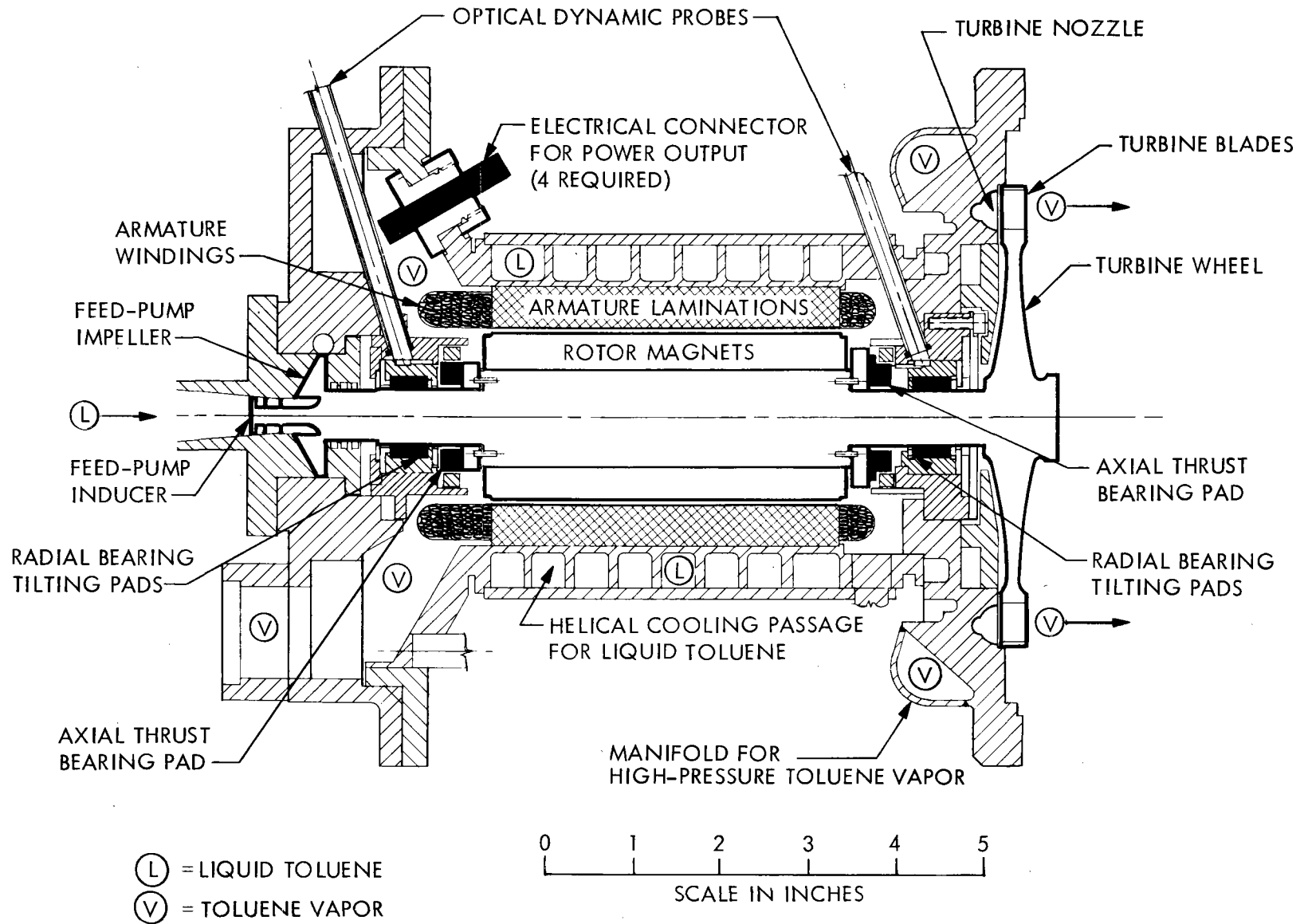

Figure 3-10. Cross-Section of TAP Assembly Showing, to Scale, Relative Sizes and Locations of Various Components

In any case, the single power module designed and tested in this program used a single 30-kWe inverter built by the Nova Electric Manufacturing Corporation of Nutley, New Jersey. The specifications for this inverter are contained in Reference 3-13 while the details of operations are explained in Reference 3-12.

The switchboard consists of a single, free-standing unit that provides the necessary electrical equipment to operate the single power module and to distribute its electrical power output either to the distribution grid or to a local, resistive load bank. In the case of the multi-module plant, the switchboard will be connected to multiple-modules to form a power plant. The block diagram (Figure 3-11) shows the relationship of the switchboard to the other elements of the power module for a single-module installation.

The function of the resistive load bank is to absorb the electrical power output of the power module when the module is operating "on-sun" but not feeding the distribution grid. This component is essential for safe operation because there is no simple way to stop the flow of heat into the working fluid in the event the module is accidentally disconnected from the grid. Only by expanding the vapor through the nozzles can the heat be removed in an acceptable, continuous manner. The load bank is desirable for test and diagnostic purposes and is also required during start-up and shutdown procedures.

The grid interface equipment is designed to deliver the generated power to the distribution grid, while ensuring that all possible safety measures are observed and that all potential classes of failure (either of the solar module or of the distribution grid) result in an orderly disconnection of the plant from the grid. A fundamental assumption underlying the use of the all-solar<sup>7</sup>, single power module or of the multiple-module plant is that the generated power capacity will be a small fraction of the power available to the grid from other sources. The distribution grid will, therefore, be comparatively insensitive to the abrupt opening or closing of the grid-interface contact.

#### D. THE CONTROL SUBSYSTEM

As with the other subsystems in the ORC power module development program, the control subsystem was designed from its conception to be part of the greater plant system. It was decided, nevertheless, in the interest of cost effectiveness and schedule, to postpone the detailed design of the control system for the entire multi-module plant until the design of the power module could be validated. It was also considered appropriate to isolate the concentrator controls from those of the combined engine and plant subsystems during the development phase of the program. The reasons for this decision were twofold:

- (1) The control system of the selected concentrator was scheduled to be designed considerably later than that of the engine. Thus, for the on-sun testing of the engine, the plan was to employ a Test

---

<sup>7</sup>In contrast to the hybrid module, which can operate with some or all of the heat input supplied by fossil fuel or other sources.

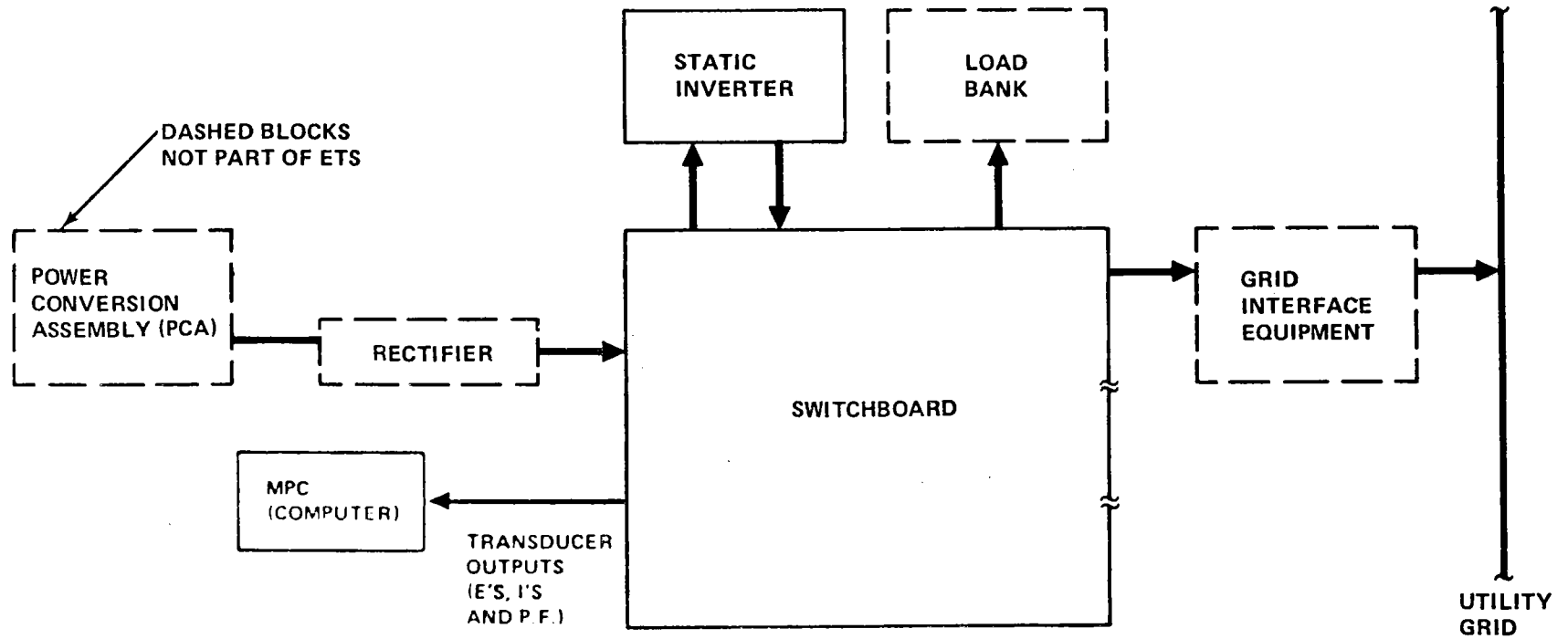

Figure 3-11. Block Diagram of Single Power-Module Electrical Power Output Equipment

Bed Concentrator (TBC) already in existence and operating at the JPL Parabolic Dish Test Site. The TBC employs an independent, tried-and-proven, drive and control system.

- (2) It was considered prudent to isolate the engine and dish control functions until each had been separately perfected. Later in the program, when the engine and its control subsystem would have been successfully tested, it would be desirable to combine the two functions in the RCIA so that they could be incorporated in the multi-module plant in an efficient, cost-effective manner. In this report both approaches are discussed.

The basic requirements for the engine control have already been mentioned, i.e., that the temperature of the working fluid is held constant at 750°F and the turbine speed is allowed to seek its own operating speed within a small range near the design value. A simplified block diagram of the control law for the vapor valve is shown in Figure 3-12. As indicated by this figure, the inner-loop control sensing the receiver shell temperature has a time constant of approximately 10 s, whereas the outer loop has a time constant of about 6 min.

Cloud passage or shading by another dish decreases the input power to the engine. In response to the measured decrease in fluid exit temperature below the set point of 750°F, the vapor valve partially closes. If the input power drops still lower, the output voltage will drop below the control voltage range of the inverter while the turbine speed continues to fall. When this occurs, the control law changes to the speed control loop, maintaining the turbine speed at a predetermined value of approximately 35,000 rev/min. If input power returns, the receiver output temperature rises and the control law reverts to the temperature control mode.

Control of the plant, whether single- or multiple-module, requires that control functions be performed at both the power-module level and plant level. The computer hierarchy that provides this control is based on the concept that each module operates autonomously, using its own RCIA. The RCIA's (or ensemble of RCIA's in the case of a multi-module plant) are under the supervisory control of the MPC, which performs the overall plant control and provides the means for collecting module- and plant-operating data. The RCIA's are connected to the MPC by a two-way serial data link. The actual hardware used for the single-module plant MPC is configured around a Data General Nova 4/X mini-computer. This unit possesses 65K words of MOS semiconductor memory and a 6.25M-word Winchester disk. The operator can communicate with the MPC by means of a Cathode Ray Tube (CRT) display, keyboard, and printer. Interface cards mounted in the Nova computer chassis perform analog-to-digital and digital-to-analog conversions as well as provide for discrete input/output (I/O) and serial data links. A magnetic tape recorder is incorporated for recording data. Reference 3-14 enumerates the functions of the MPC and RCIA's as follows:

- (1) Read keyboard or remote entries from the plant operator.
- (2) Send data to and receive data from the RCIA at each power module via the serial data link.

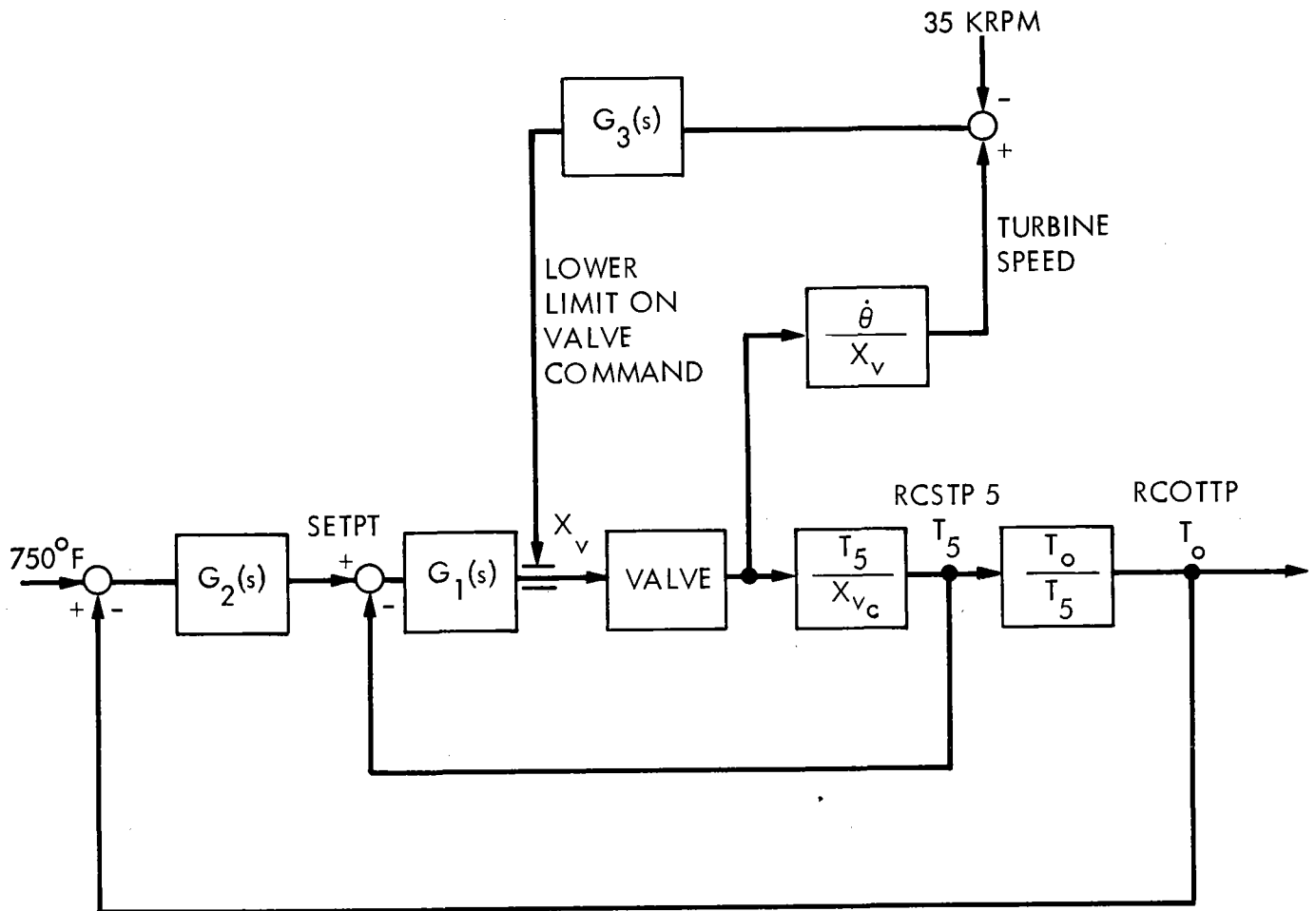

$$G_1(s) = \frac{1.5}{0.5s + 1}, \text{ \% VALVE}/^\circ\text{F}$$

$$G_2(s) = 0.00153 \frac{190s + 1}{s}, \frac{^\circ\text{F}/\text{S}}{^\circ\text{F}}$$

$$G_3(s) = 0.4 \frac{10s + 1}{s}, \frac{\%/\text{S}}{\text{KRPM}}$$

Figure 3-12. Vapor-Valve Control Law

- (3) Collect analog and discrete data from the ETS and from the weather station.
- (4) Display data on the operator's CRT.
- (5) Print data in real time on the local printer.
- (6) Record all data collected on magnetic tape for later playback.
- (7) Perform specified logic functions relative to control of the ETS and the power modules.
- (8) Compute ephemeris data for the concentrator and transmit to all RCIA's.

Each power module is controlled by an RCIA and its software program, the Remote Operational Program (ROP). The RCIA is a Z80-based microprocessor installed in a weatherproof NEMA enclosure located at the base of the concentrator. The processor and associated support and I/O circuitry are built on STD BUS boards by Pro-Log Corporation and are designed to operate in a wide temperature range (-25° to +49°C). The RCIA is under the high-level supervision of the MPC by means of commands on the MPC/RCIA serial data link. The functions that the RCIA must perform are:

- (1) Read any of the specified data messages from the MPC serial data link.
- (2) Synchronize its one-second cycle to the MPC by receiving the SYNC command on the serial data link.
- (3) Send a long or short data message or a circular buffer dump to the MPC on request.
- (4) Perform debug functions as required.
- (5) Perform power module automoding logic.
- (6) Perform detailed PCA control.
- (7) Perform detailed concentrator control.

The hierarchical relationship between the various control elements permits the complete plant to operate unattended. The computer logic that enables this to be done is called Automoding, also discussed under control plant requirements. Figure 3-13 depicts the logic structure. As indicated previously, plant modes and energy transport control modes are performed by the MPC, while the power module modes, PCA modes, and concentrator modes are performed by each RCIA. The commands that originate with the MPC are distributed to the RCIA at each module by the serial data links. Reference 3-12 enumerates and describes the function of each plant mode as follows:

- (1) Manual Plant Mode. Allows the plant operator to input the power module mode of individual modules.

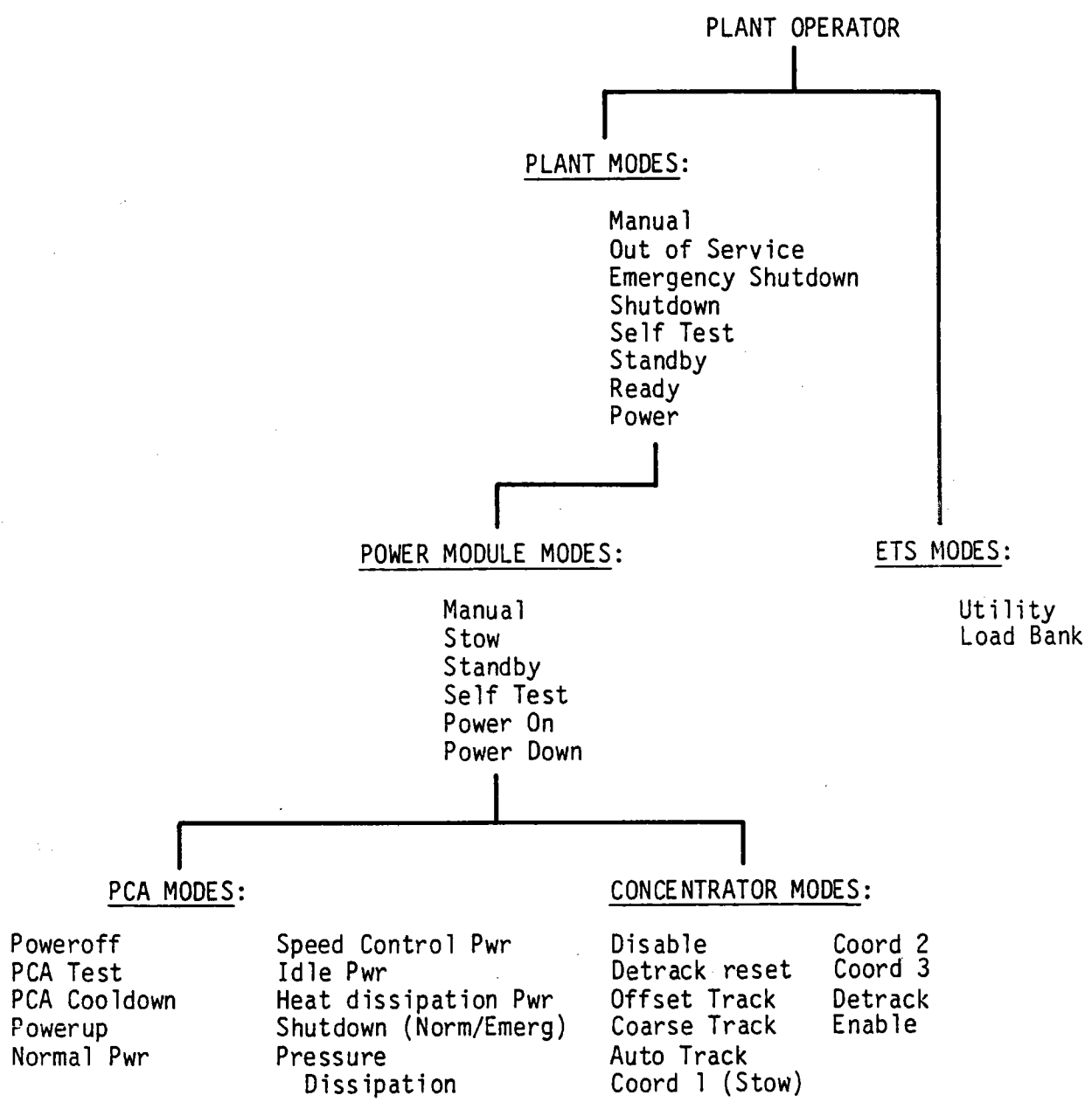

Figure 3-13. Typical Plant Moding Hierarchy



- (2) Out of Service. Disables the operation of all power modules. This plant mode is provided to allow for maintenance or other intentional down time.
- (3) Emergency shutdown. Shuts the plant down in the normal manner but sets the Emergency Shutdown Fault flag, which prevents the plant from restarting without operator intervention.
- (4) Shutdown. Shuts all power modules down, waits until they have completed shutdown and are stowed, and then changes the Plant Mode to Ready. The plant will restart if the following appropriate conditions are met:
  - (a) Self Test. Commands all modules to Self-Test mode.
  - (b) Standby. Commands all modules to Standby.
  - (c) Ready. The normal enabled mode of the plant while waiting for conditions suitable for generating power.
  - (d) Normal Power. The plant mode when power is being generated. Power generation will continue until some reason exists to stop. The mode will then be changed to Shutdown or Emergency Shutdown.

The power module modes may be commanded to the RCIA from the MPC or may be determined by mode logic within the RCIA. The modes are implemented by generating mode commands to the PCA control and the concentrator control. A summary of the functions performed by the Power Module Modes is as follows:

- (1) Power Module Manual. Allows processing of PCA mode and concentrator mode commands from the plant operator.
- (2) Stow. Waits for PCA mode Poweroff and then commands the concentrator to stow.
- (3) Standby. Commands the concentrator to Offset Track.
- (4) Self Test. Performs a sequence of tests on the concentrator and PCA to determine that the module is healthy.
- (5) Power On. First initiates Self-Test mode. If the self test passes, the concentrator is brought on-sun, the turbine is started, and power is generated until a stop criterion is reached.
- (6) Power Down. Takes the concentrator off-sun, waits for the turbine to shut down, and then commands Stow mode.

## SECTION IV

### DEVELOPMENT TESTS OF THE ORC MODULE COMPONENTS AND SUBSYSTEMS

The original program plan and schedule for the Small Community Solar Thermal Power Experiment called for an orderly and systematic progression from conceptual design through preliminary and detailed design of the various components and subsystems, followed by an "all-up" test of a complete power module and single-module plant control system. Upon successful completion and qualification of the power module by means of a thorough test program, final design of the multi-module plant was to be initiated. Several factors prevented this course of action from being carried out as planned:

- (1) The concentrator, which was being developed by General Electric Company under a separate technology development contract and which was intended to be used for the module, fell behind schedule and would not be ready in time to meet the proposed completion date.
- (2) The various components and subsystems slated for incorporation in the module exhibited widely varying degrees of readiness. In the interest of minimizing the expenditure of resources and moving the program forward along the shortest time path, fabrication and testing was started on some components, while other components closely associated with it were still only in the design stage.
- (3) Changes in program emphasis and funding levels by the Department of Energy eliminated early work on the multi-module plant control system and precluded following multiple development paths for critical power-conversion subsystem elements.

These factors, as well as persistent development problems with excessive bearing wear (See Reference 3-11) resulted in a development program that fell behind its intended goals. Furthermore, plans to continue development of the power module and to build the multi-module plant foundered when the negotiating parties (DOE and FACC) failed to reach agreement on the terms of the contract.<sup>8</sup> Nevertheless, the ORC development task succeeded in producing significant, well-documented, experimental data and test results. Table 4-1 lists the more significant test programs and references that describe each program in detail.

When the GE concentrator failed to meet the projected delivery date of the power-conversion assembly, it was decided to continue the PCA development and test it on a test bed concentrator at the JPL Parabolic Dish Test Site, Edwards Air Force Base (Reference 4-1). Two 11-m-diameter TBCs had been designed and put in place at the Test Site as a facility for concentrating solar flux to test materials, receivers, engines, and other components. The

---

<sup>8</sup>The Department of Energy subsequently issued a request for new proposals for a 100-kWe plant to be located at the same site in Osage City, Kansas. Ford Aerospace and Communications Corporation did not elect to respond to this request.

Table 4-1. Tests Performed During Development of the Organic Rankine Power Module

SCSE Report Number	Test	Date
014	Test Results Summary for Receiver Qualification Tests	29 June 1981
015	Test Report: Receiver Qualification Tests	6 August 1981
016	Test Results Summary for Control Subsystem Qualification Test	6 August 1981
017	Test Report: Control Subsystem Qualification Tests	26 August 1981
018	Test Results Summary for the Inverter Acceptance Test	11 September 1981
019	Test Results Summary for the Switchboard Acceptance Test	29 September 1981
020	Test Results Summary for Power Conversion Subsystem (PCS) Qualifications Tests	26 October 1981
TR042	Test Results for the Development Receiver Core	11 June 1981
021	Test Results Summary for PCS/RCR Compatibility Test	14 January 1982
022	PCS/RCR Compatibility Tests at FACC	16 April 1982
023	Power Conversion Assembly Verification Test on the TBC and Energy Transport Subsystem Qualification	23 April 1982
	PCS Qualification Test Report <sup>a</sup>	November 1981
Task 11	Final Report, Evaluation of Carter Reciprocator Steam Engine <sup>b</sup>	May 1981

<sup>a</sup>Performed and reported by Barber-Nichols, under subcontract to FACC.

<sup>b</sup>Performed and operated by W. J. Wingenbach, Carter Enterprises, under subcontract to FACC.

TBC's multi-faceted design permitted the experimenters to exercise some control over the flux distribution at the focal plane by adjusting the mounting screws that secured the mirror facets to the underlying structural support.

As previously mentioned, the tracking and control system for the concentrator was self-contained and autonomous and hence placed no requirements on the component being tested. To control the onset and termination of solar heating of the receiver under test, the concentrator was provided with a new, enlarged, water-cooled aperture plate and sliding shutter assembly. Keeping the shutter in the "closed" position permitted the concentrator to "acquire" the sun and to track it accurately without exposing the receiver or engine to the solar flux. Opening the shutter by means of a remote control enabled full solar flux to enter the receiver aperture within a few seconds. Similarly, the shutter was activated by fault-detection systems so that it would slide shut and cut off the solar flux in an emergency or if commanded to do so by the operator. The test of the power-conversion assembly and of the energy transport system was intended as a precursor to the test of an "all-up", single-module power module, which was to employ the GE-designed PDC-1 concentrator<sup>9</sup> and which was to possess a nearly autonomous, complete plant control system.

Although the final system test of a single-module plant did not take place, two important subsystem tests were completed that warrant further discussion. The first of these, a test of the power-conversion assembly on a test bed concentrator, demonstrated the compatibility of the various components and subsystems and verified the soundness of the design approach for the overall system although it did reveal a serious deficiency in the engine bearing design. The second subsystem test was performed to verify the effectiveness of the solution to the bearing problem (See Reference 3-11).

#### A. POWER-CONVERSION ASSEMBLY VERIFICATION TEST AND ENERGY TRANSPORT SUBSYSTEM QUALIFICATIONS

This test, the subject of Reference 4-2, covers both the test of the PCA and the Energy Transport Subsystem. The material presented in this overview has, for the greater part, been abstracted from that publication, which presents the best description of the procedures for operating the test apparatus and provided the most complete discussion of the results.

The test was conducted at the PDTs during the months of February and March 1982 when more than 33 h of actual on-sun operation was achieved. The test site, described in Reference 4-1, provided the engineering personnel from FACC with an operating test facility that included a test bed concentrator and meteorological station. Test-site personnel operated both these facilities and provided assistance with installation, removals, and maintenance. The subsystem under test, as well as most of the computer-operated test instrumentation and controls were operated by, and under the supervision of, FACC employees.

---

<sup>9</sup>The decision to use the PDC-2 was not made until later in the program.

The primary objective of the test series was to validate the design of the PCA, switchboard, and inverter, requiring that the module be operated under a wide range of operating conditions and be subjected to artificially imposed perturbations and "glitches." Because many of the components or subsystems had never been run together, the interfaces between these elements needed to be verified.

## B. TEST OBJECTIVES

The overall objectives for the verification tests on the TBC, called out in the test plan and in the test report (Reference 4-2), were twofold: (1) to verify operating characteristics of the elements of the SCSE single-module system and (2) to determine the compatibility of each interfacing subsystem/assembly. The specific objectives are listed below and identified as "primary"; other desirable objectives are identified as "secondary."

### 1. Primary Objectives

- (1) Verify that all PCA operational control modes were in accordance with SCSE system specification requirements.
- (2) Verify stable control of the engine/receiver.
- (3) Verify the power control approach, i.e., control of the dc input voltage at the preselected level by the inverter.
- (4) Determine the performance and efficiency of each element of the system (except the concentrator), such as the receiver, PCS, and inverter.
- (5) Determine output power as function of incident solar flux and ambient conditions.
- (6) Verify that the electrical energy quality was within SCSE system specification requirements.
- (7) Determine system transient response during partially cloudy days.
- (8) Determine system characteristics/response to grid dropouts.
- (9) Determine the boundary contour for acceptable noise level ( 85 dBA).
- (10) Verify grid interface compatibility.

## 2. Secondary Objectives

- (1) Validate operating procedures.
- (2) Gather data to assist in establishing maintenance requirements.
- (3) Gather data to contribute to a determination of degradation of PCA performance with time.
- (4) Gather failure rate and time-to-repair data.
- (5) Validate safety provisions and procedures.
- (6) Gather data necessary to determine variation of receiver performance with ambient conditions.
- (7) Gather data relative to degradation of toluene quality.

The test instrumentation, because it was highly computerized, also needed to be "debugged" and validated. The final goal was to connect the electrical output of the module to the Southern California Edison distribution grid and to demonstrate that the EST and control systems could operate in a multi-module mode. The single-plant module was the "first of a kind" in that it possessed an automated "plant" control that used a master plant-control computer; local computers subordinate to it operated each engine.

## C. TEST CONFIGURATION

Figure 4-1 shows the power-conversion assembly mounted at the focus of a test bed concentrator at the Parabolic Dish Test Site. The separate mirror facets had been previously adjusted and aimed to produce a flux distribution at the receiver similar to that predicted for a "true" paraboloidal reflector of slightly greater rim angle.<sup>10</sup> This was done to make the concentrator performance compatible with the requirements of the receiver, a goal that was met satisfactorily, judging from the measurements of the receiver temperature (Figure 4-2). The schematic showing the test setup (Figure 4-3) can be compared with the originally proposed SCSE multi-module system (See Figure 2-1). Except for the concentrator, the components and subsystems tested are described elsewhere in this report under the appropriate subsystem headings.

---

<sup>10</sup>As indicated previously, the concentrator originally selected for the module was the GE-designed PDC-1. The Acurex-designed PDC-2 was to have replaced it in the more recent designs.

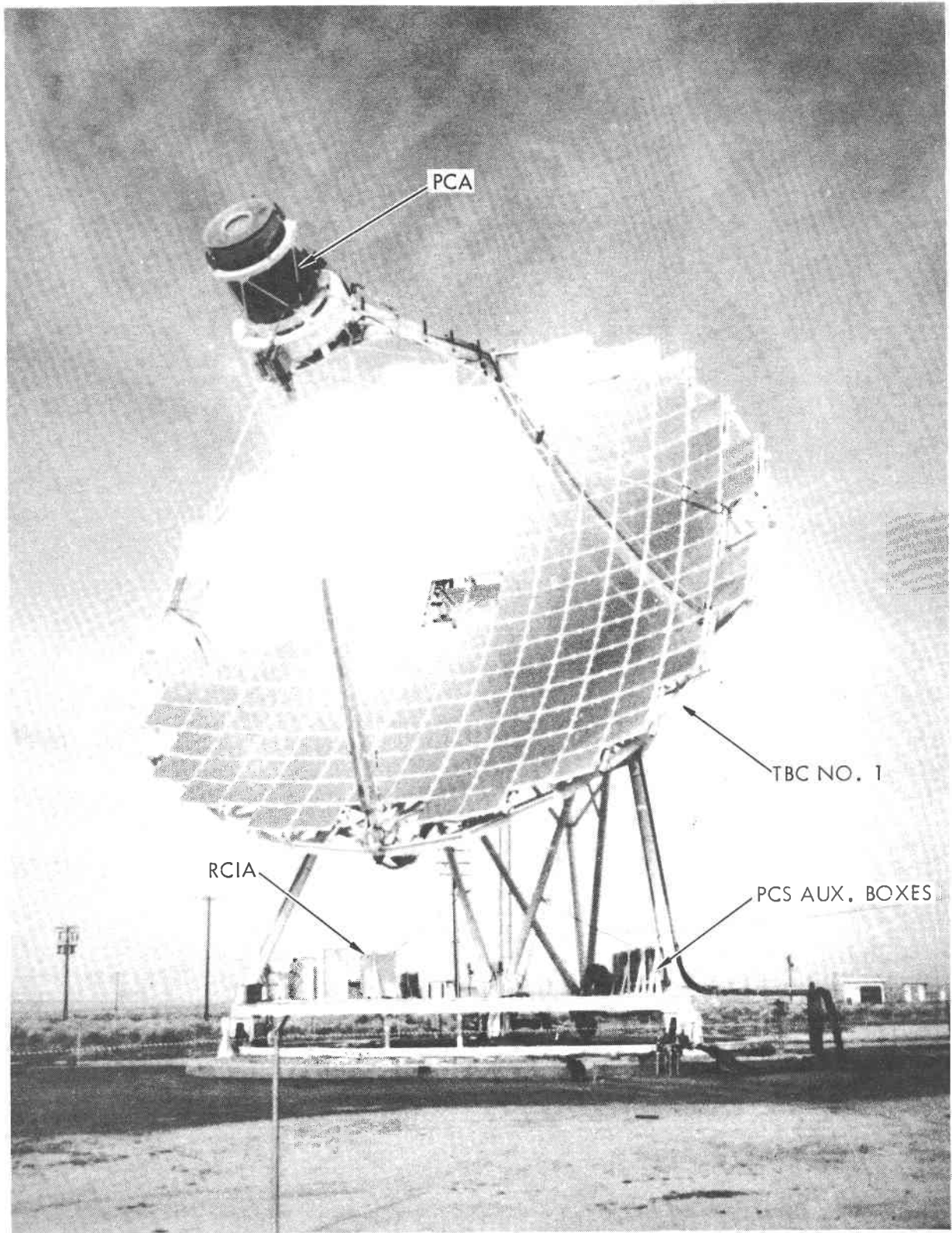

Figure 4-1. Power-Conversion Assembly and Electrical Boxes on Test Bed Concentrator No. 1

4-7

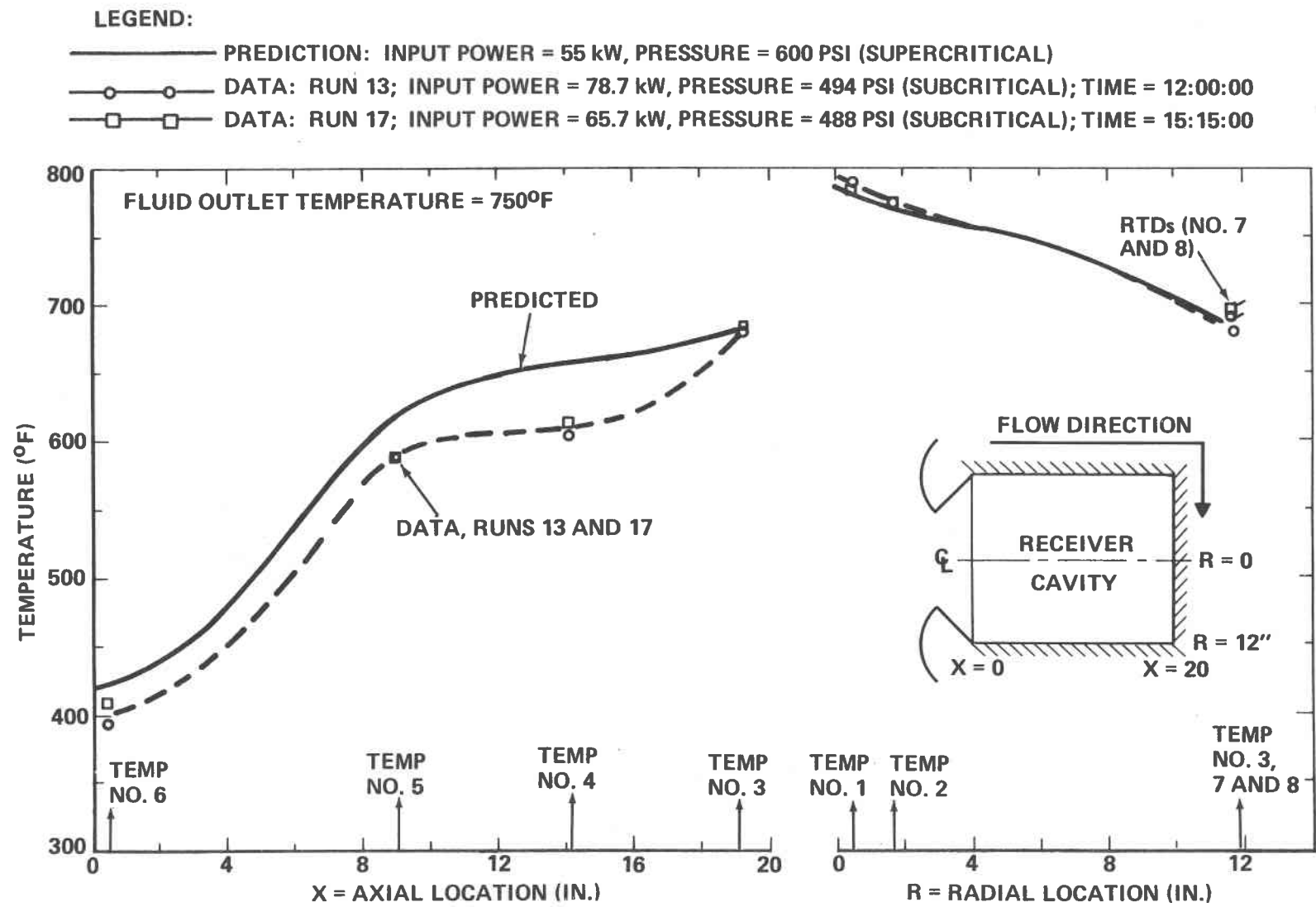

Figure 4-2. Comparison of Predicted and Measured Receiver Wall Temperatures (Runs 13 and 17)



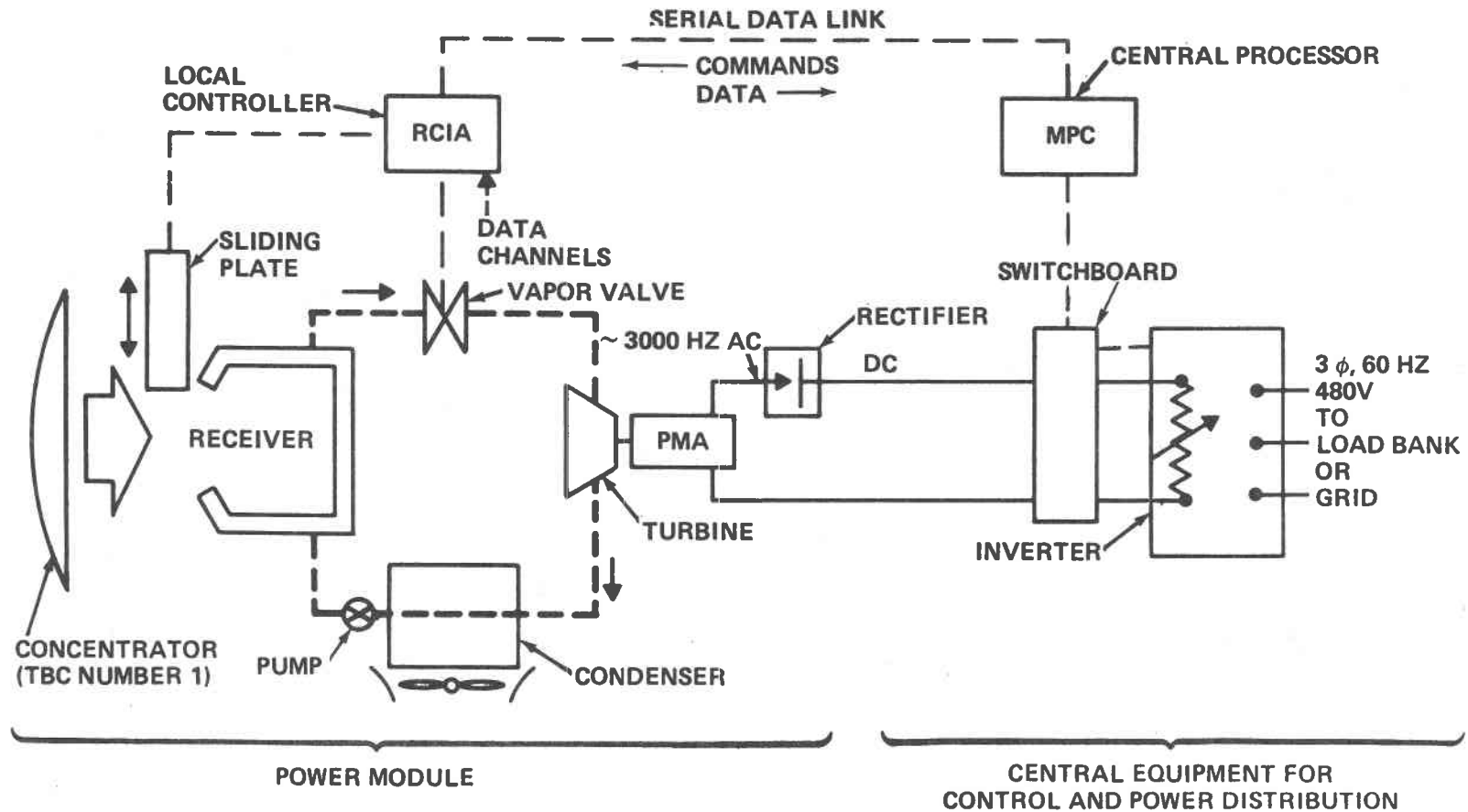

Figure 4-3. Simplified Schematic Diagram of Single-Module Experiment Hardware at Parabolic Dish Test Site

## 1. Test Operations

The process of running the tests and obtaining the data that would yield the final performance figures is best exemplified by the following description in this subsection, which is a verbatim excerpt from Reference 4-2:

A typical run would begin by bringing the MPC "up" by setting the internal clock, initializing the tape, and going through its checks at the same time. The function of the sliding plate was checked and left in the "remote" mode so it could be closed by the computer in the RCIA if any serious fault occurred. The concentrator was then brought "on-sun" by rotation in azimuth in a clockwise direction looking down at the dish (the required elevation angle had previously been reached). As the sun was first acquired, the plate was opened to help protect the mounting ring and water hoses from the beam, then closed as the sun spot moved across the plate to prevent the beam from entering the open aperture. After the TBC sun tracker centered the beam at the proper location (as verified by viewing and TV monitor) and the appropriate items on the checklist were completed, the sliding plate was opened and the receiver began to heat up. The heat-up period before turbine start was approximately 4 to 5 min for the full mirror area and insolation of  $900 \text{ W/m}^2$  or greater. Longer periods were required for less power input. Once the sliding plate was opened, the startup sequence was entirely under computer control. The normal sequence during the startup period was:

- (1) When receiver shell temperature began rising, PCA mode changed to "powerup" and pumps and fan started.
- (2) The control valve opened slightly to relieve toluene pressure in the receiver when it reached 675 psi. This cycling ("burping") continued to maintain a safe pressure.
- (3) The turbine started when receiver shell temperature number 5 (RCSTP5) reached  $680^\circ\text{F}$  or when turbine speed was greater than 5000 rev/min and RCSTP5 was greater than  $300^\circ\text{F}$ .
- (4) After turbine start, the flow was controlled to maintain RCSTP5 at a computed (changing) set point to allow the receiver outlet temperature to reach its normal operating value of  $750^\circ\text{F}$ . This set point started at about  $580^\circ\text{F}$  and increased as conditions changed. A period of 20 to 30 min or more was required to reach steady-state receiver temperatures. An even longer period was required to stabilize regenerator and condenser conditions.

## 2. Test Parameters

The primary test parameters (variables) and their purposes are listed in Table 4-2 as:

- (1) Concentrator masking (Figures 4-4, 4-5).
- (2) Insolation.

- (3) Transient input power (door closings or clouds).
- (4) Inverter input (dc) voltage level.

The insolation available during the test period covered the range of zero to one instance of slightly over 1.0 kW/m<sup>2</sup>. A number of days were so cloudy, or the clear periods so infrequent, that tests were not possible. At least two weeks had only one or two days of good sunshine. It was determined that the lowest insolation for sustained PCA operation was approximately 300 W/m<sup>2</sup> for the full TBC area. At this level all SCSE subsystems would be operating at or slightly above the parasitic power level, i.e., little net power would be produced.

Table 4-2. Test Parameters

Parameter	Purpose
Masking of the concentrator, i.e., variation in the area of the reflective surface	Vary the maximum solar power available to evaluate part-load efficiency
Insolation	Operate under real conditions
Transient power conditions due to sliding plate (door) closings or clouds	Evaluate the stability and performance of control subsystem
Voltage level at input to inverter (equivalent to turbine speed)	Evaluate engine performance vs. speed
Operate the unit in a pre-selected mode including simulated emergency shutdowns and hot restarts	Check ability to operate properly under all conditions and modes
Normal, steady-state operation	Evaluate component performance and efficiency (computer program "OPWEG")
Fan speed	Determine trade-off between fan parasitic loss and PCS performance degradation
Inverter load (load bank or grid)	Check all inverter options and ability to switch automatically to proper load



Figure 4-4. Test Bed Concentrator with 25% Checkerboard Masking Pattern



Figure 4-5. TV Monitor Showing 25% Masking Spots on Back Wall of Receiver

Insolation measurements were taken by a local Eppley pyrhelimeter, first by a unit that was mounted on a tracker south of TBC No. 1 and then with an Eppley mounted directly to the TBC structure and aligned with the sun. Most tests were run with the dish-mounted Eppley, which had the advantage of having the TBC act as an accurate tracker and by showing when the sun was acquired and detracked. Insolation data were also obtained from the JPL weather station. Weather station data were updated at one-minute intervals (by JPL) and included two Kendall and one Eppley pyrhelimeters and a pyranometer. The local Eppley reading was modified to account for an average circumsolar effect in the calculation of the power available to the TBC.

Input transients were obtained by closing the water-cooled sliding plate (door) for periods of 30 s to 5 min. Clouds were present on many occasions but were not so convenient (or controllable) as closing the door. It was found that the engine would keep running for about 4.5 min after door closure at normal operating conditions, provided the control subsystem immediately commanded "idle" mode (35,000 rev/min turbine speed) to maximize the running time.

The dc voltage setting in the inverter was varied from about 480 to 560 V to determine the best operating point in terms of engine efficiency. It was found that the lower voltages (lower turbine speed) were best from this standpoint, and most of the testing was in the range of 500 to 520 Vdc to the inverter (Reference 4-2).

#### D. TEST RESULTS

The test program was successful and met all major objectives although it did reveal a major shortcoming in the bearing design that was not solved until much later in the testing program. Key results for the tests are summarized in Table 4-3.

The performance and characteristics of the PCA, ETS, and control system were verified, and stable operation was demonstrated over a wide range of operating conditions and also when subjected to abrupt changes to create "worst case" situations. The control system demonstrated the ability to hold operating parameters well within specified limits, i.e., the fluid temperature at the receiver outlet was controlled to  $750 \pm 5^\circ$  despite short-period insolation variations of over two-to-one. Similarly, the output voltage could be held to  $\pm 5$  V of the selected value set for the inverter control.

The automatic data measuring and recording system performed excellently, yielding more than 100 performance/diagnostic measurements per second during each test. Although the computation and plotting of data could not be done in "real time," the data were reduced during slack times or at the end of the day so that results were available to modify the test plan on a daily basis if desired.

Two incidents occurred that resulted in significant delay of the test series: the control valve became inoperative because of contamination in the commercially procured servo unit, and the inverter failed when it was first connected to the power-distribution grid. Both problems were solved although complete verification of the inverter control had not been established for

Table 4-3. Parabolic Dish Test Site Test Summary

Date (1982)	Test No.	Run No. (Tape No.)	Run Duration	Conditions	Purpose/Test Parameters/Problem Areas
Feb 8	1	3 (02082)	4 Min	<ul style="list-style-type: none"> <li>● 25% Masking of TBC (75% of area available)</li> <li>● Power to load bank (Runs 3 thru 20)</li> </ul>	<ol style="list-style-type: none"> <li>1) Initial check-out</li> <li>2) Receiver shell temp (RCSTP5)* drift, automatic shut-down after 1 min., restarted for a 4 min. cool-down.</li> </ol>
Feb 11	2	5 (02111)	20 Min	<ul style="list-style-type: none"> <li>● 25% Masking</li> <li>● Solar flux 700-900 W/m<sup>2</sup></li> </ul>	<ol style="list-style-type: none"> <li>1) Control system and component charts.</li> <li>2) Automatic shut-down after 20 min. due to A/D calibration channel outside of limits. Control valve was inoperative after shutdown, requiring removal of valve and replacement of valve driver.</li> </ol>
Feb 23	3	7 (02231)	5.3 Hr.	<ul style="list-style-type: none"> <li>● 25% Masking</li> <li>● Early high clouds, then 40 min. cloud, followed by clear conditions</li> </ul>	<ol style="list-style-type: none"> <li>1) System response to door closure (simulated cloud passage) for 0.5, 1, 2, &amp; 5 minutes.</li> <li>2) Vary voltage level (inverter setting), and thus turbine speed.</li> <li>3) Check speed control mode.</li> <li>4) Response to 40 min. cloud (with ~50% insolation.)</li> <li>5) Hot re-start after shut-down.</li> </ol>
Feb 25 (AM)	4	8 (02251)	1.4 Hr.	<ul style="list-style-type: none"> <li>● No masking of TBC (full area) for Runs 8 thru 17</li> <li>● Clouds of varying intensity</li> </ul>	<ol style="list-style-type: none"> <li>1) Check operation in moderate to heavy cloud cover.</li> <li>2) Early shutdown and restart due to clouds.</li> <li>3) Run stopped after bad receiver outlet temp. sensor (RCOTTP)* detected.</li> </ol>

\*All instrumentation channels are defined in Appendix B.

Table 4-3. (Cont'd)

Date (1982)	Test No.	Run No. (Tape No.)	Run Duration	Conditions	Purpose/Test Parameters/Problem Areas
Feb 25 (PM)	5	9 (02252)	2.7 Hr.	● No clouds, ~900 W/m <sup>2</sup>	1) Check response to three 0.5 min. and two 1 min. door closures. 2) Check effect of modified control constants. 3) Evaluate effect of low fan speed.
Feb 26	6	11 (02261)	4.1 Hr.	● Thin clouds growing heavier during last part of run	1) Door closures of 1 min. 2) Check speed control mode during door closure of 5 minutes, with a hot restart. 3) Evaluate control constants.
Mar 2	7	12 (03021)	0.7 Hr.	● Heavy broken clouds with 5 min. clear intervals	1) Check operation during broken clouds. 2) Valve did not respond after normal shut-down, and required filter change.
Mar 3	8	13 (03031)	6.7 Hr.	● Clear with winds of 10-20 mph with gusts to 28 mph	1) Evaluate different periods of door closures. 2) Steady-state operations in mid-day (~2 Hr.) 3) Check speed control mode. 4) Simulate emergency shutdown, then hot restart. 5) Effect of fan speed for windy conditions.
Mar 4	9	14 (03041)	1.6 Hr.	● Clear day	1) Evaluate effect of inverter <sup>1</sup> voltage setting (turbine speed) 2) RCIA dropout at end of test.

Table 4-3. (Cont'd)

Date (1982)	Test No.	Run No. (Tape No.)	Run Duration	Conditions	Purpose/Test Parameters/Problem Areas
Mar 5	10	15 (03051)	1.3 Hr.	<ul style="list-style-type: none"> <li>Overcast, insolation 200-400 W/m<sup>2</sup></li> </ul>	<ol style="list-style-type: none"> <li>Determine minimum solar flux for operation.</li> <li>Evaluate controls and multiple restarts.</li> </ol>
Mar 12	11	16 (03121)	1.6 Hr.	<ul style="list-style-type: none"> <li>Mostly clear sky, ~920 W/m<sup>2</sup></li> </ul>	<ol style="list-style-type: none"> <li>Steady state operation into load bank.</li> <li>Check mods to power and energy program including updated effective area.</li> </ol>
Mar 18	12	17 (03181)	1.1 Hr.	<ul style="list-style-type: none"> <li>Full area of TBC (Runs 4 thru 17)</li> <li>Series of small clouds, insolation ~920 W/m<sup>2</sup> during clear periods</li> </ul>	<ol style="list-style-type: none"> <li>Normal operation with scattered clouds.</li> <li>Inverter dc contactor malfunction, but software controlled turbine speed without brake operation.</li> </ol>
Mar 19 (AM)	13	18 (03191)	2.8 Hr.	<ul style="list-style-type: none"> <li>50% masking of TBC</li> <li>Clear sky, over 1000 W/m<sup>2</sup> at start</li> </ul>	<ol style="list-style-type: none"> <li>Low power, steady state run.</li> <li>Evaluate low fan speed.</li> <li>Evaluate inverter voltage setting (turbine speed).</li> <li>Short period of high power to inverter using both power supply and turbine at 95% valve position (rapid cool-down mode).</li> </ol>
Mar 19 (PM)	14	19 (03192)	0.4 Hr.	<ul style="list-style-type: none"> <li>25% masking</li> <li>Clear sky, 800 W/m<sup>2</sup></li> </ul>	<ol style="list-style-type: none"> <li>Check 25% masking conditions.</li> <li>Evaluate effect of start-up with bypass valve closed (Runs 18 through 21).</li> </ol>



Table 4-3. (Cont'd)

Date (1982)	Test No.	Run No. (Tape No.)	Run Duration	Conditions	Purpose/Test Parameters/Problem Areas
Mar 22	15	20 (03221)	3.0 Hr.	<ul style="list-style-type: none"> <li>● 25% masking</li> <li>● Flux 900 W/m<sup>2</sup> with some high clouds</li> </ul>	<ol style="list-style-type: none"> <li>1) Medium power, steady state run.</li> <li>2) Evaluate high and low fan speed and voltage setting.</li> <li>3) Use of power supply with PCA into load bank.</li> <li>4) Temporary shutdown due to sensor malfunction, test continued after mods.</li> </ol>
Mar 26	16	21 (03261)	0.6 Hr.	<ul style="list-style-type: none"> <li>● Full area of TBC (no masking)</li> <li>● Flux ~900 W/m<sup>2</sup> until cloud-caused shutdown</li> <li>● Power to grid</li> </ul>	<ol style="list-style-type: none"> <li>1) Check out power-to-grid mode.</li> <li>2) Inverter malfunction when "idle" condition reached.</li> <li>3) MPC drop-out at end of test.</li> <li>4) Inverter components accidently damaged during post-test checkout, requiring repair at Nova.</li> </ol>
			Σ = 33.6 Hr.		

"on-sun" operation by the end of the test series. Considering the magnitude and scope of the design challenge and the severe requirements imposed on the module and its control system, the test must be regarded as highly successful.

### 1. The Concentrator

The TBC was a part of the PDTs test facility rather than an element of the ORC module under development, but its input to the power conversion was the first in a series of steps and needed to be evaluated if a valid assessment were to be made of the PCA performance. Using estimates of TBC performance and the measured insolation from the local Eppley pyrhelimeter, the OPWEG program calculated the power input in real time, once per second. In the calculation procedure used, a "circumsolar factor" of 0.965 was applied, a factor that is difficult to justify at the high values of insolation actually measured (above 900 W/m<sup>2</sup>) and considering the large size of the receiver aperture. The effect of using the "circumsolar factor" is to make the module appear more efficient than it actually is.

### 2. The Receiver

The receiver, which had been considered a high-risk component at the beginning of the program, proved to be one of the most successful. The test of the PCA on the TBC provided important experimental data of two kinds for the receiver:

- (1) Overall receiver performance.
- (2) Detailed receiver temperature distribution.

The overall receiver performance was evaluated using the computer program OPWEG (Reference 4-3) as explained and reported in Reference 4-2. Typical results are shown in Figures 4-6, 4-7, and 4-8, which also serve to show how the data are presented to the experimenters after using the OPWEG program. Note that on a given plot a maximum of three variables may be selected to be plotted against time.

The second result, the detailed temperature distribution, was obtained by monitoring the output of thermocouples located at various points in the receiver body -- much the same as was done during tests performed in the receiver-development test explained and presented in References 3-7, 3-8, and 4-4. As seen in Figure 4-2, the curve of observed temperatures follows the predicted value closely and is "conservative" in that measured values are lower than predicted values all along the receiver, with no local "hot spots" in evidence.

### 3. Power-Conversion Subsystem

The input to the Power-Conversion Subsystem (PCS) is the thermal energy output of the receiver while the first power output able to be measured

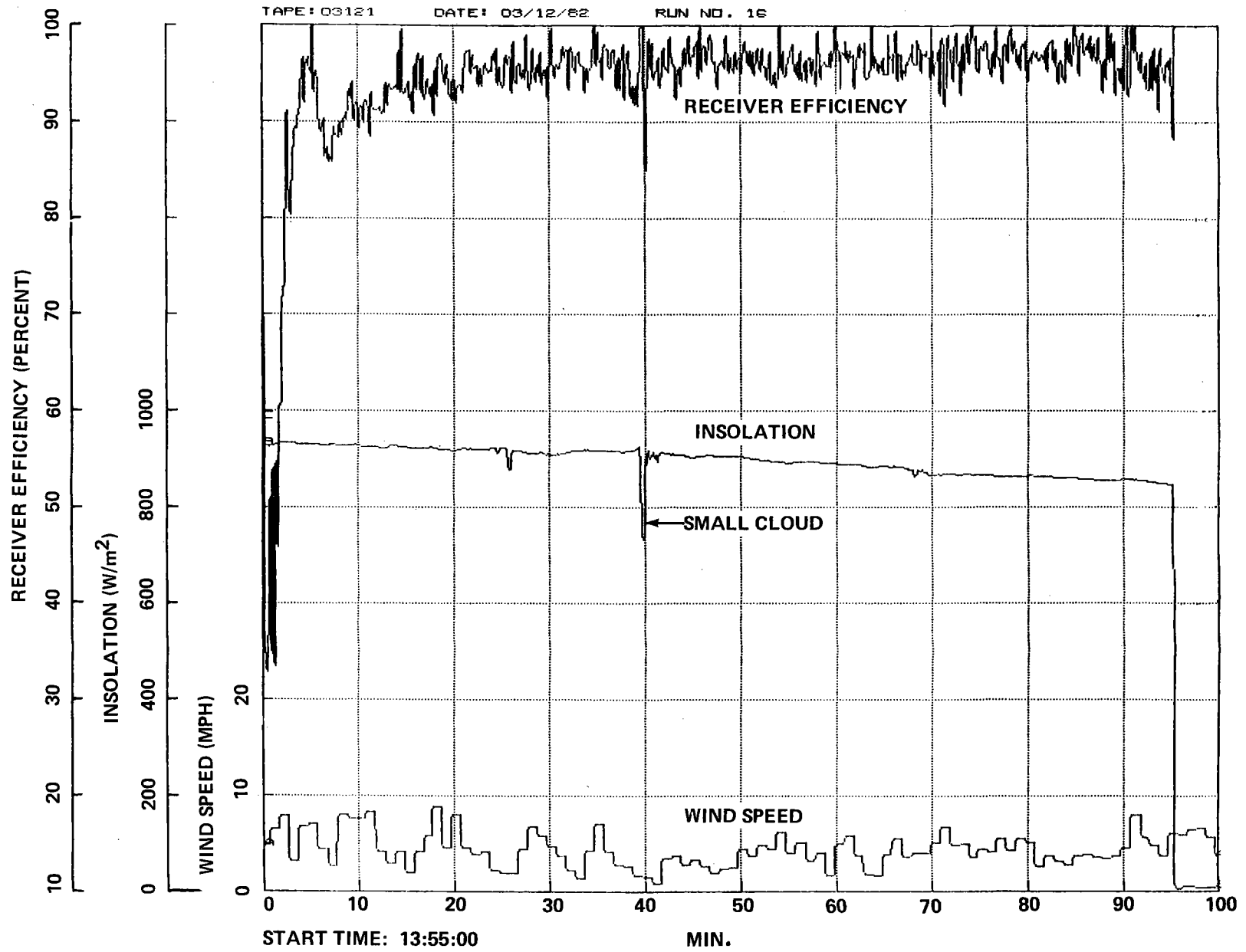

Figure 4-6. Typical Receiver Efficiency Plot (Run 16, Test No. 11)

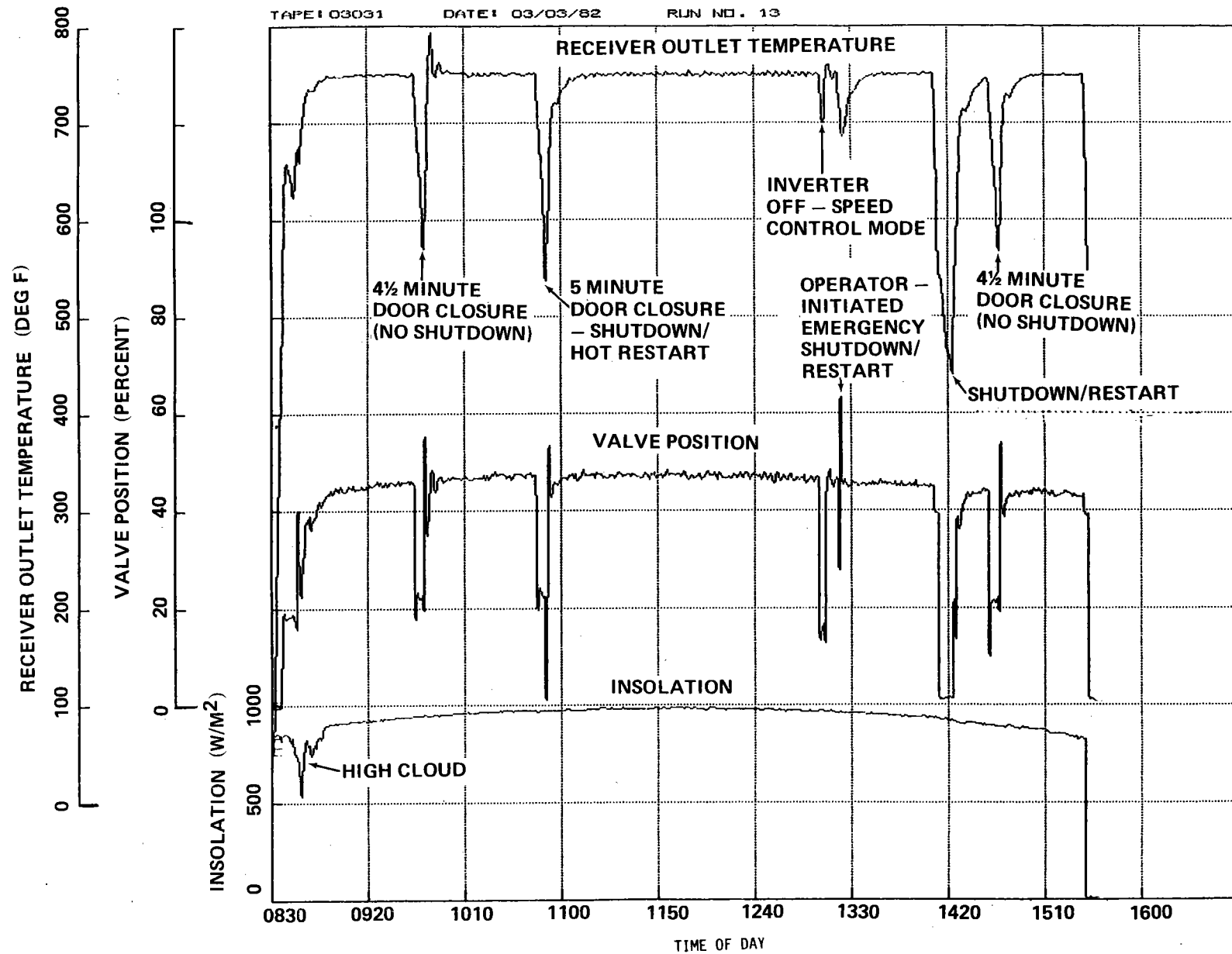

Figure 4-7. Receiver Fluid Outlet Temperature vs. Valve Position (Run 13, Test No. 8)

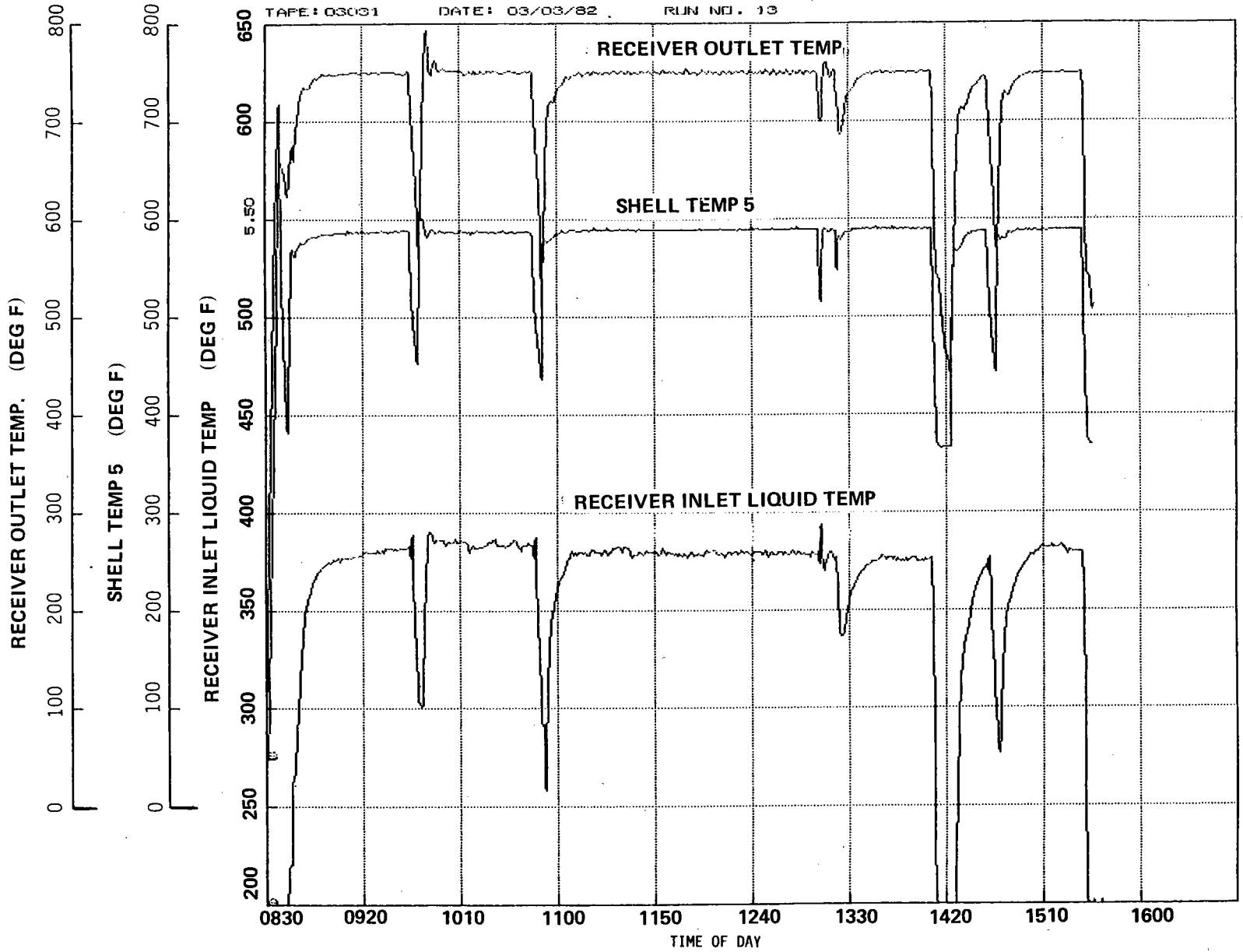

Figure 4-8. Receiver Temperatures for Run 13 (Test No. 8)

is the dc electrical output of the rectifier. The paucity of available data arises from the fact that the Turbine/Alternator/Pump Assembly is a unitary design in which it is not possible to separate the performance of the various components (pump, turbine, alternator). Even on the specially built fixture employed during component development, these measurements were difficult to disaggregate, and estimates of component performance involved suppositions, extrapolation, and inaccuracies because of the large forces involved. Abrupt decreases in output were due to deliberate shutter closings or operator-initiated shutdowns identified in Figure 4-7. Figure 4-9 presents a time history showing how the output and efficiency of the PCS varies as a result of the abrupt changes in input identified in the other plots from this run (No. 13, test No. 8). The PCS efficiency tabulated in Table 4-4 is best represented in Figure 4-10 where net power is plotted against thermal power input to the PCS. The reference curve was taken directly from a run performed during the PCS qualification test (Reference 4-5).

PCS parasitic power, which was identified and subtracted to get the net power output, included power to run the PCS fan, boost pump, valve drivers, data transmitters, etc. Actual output power was measured at the switchboard with a wattmeter.

#### 4. Toluene Analysis

An original, and still unresolved, concern with the ORC engine is the possibility of degradation of the toluene after prolonged operation at high temperatures. After a thorough search of the literature and discussion with individuals with ORC experience, it was concluded that toluene degradation would not be a problem if air was effectively excluded and the working fluid temperature was kept below 427°C (800°F). At the same time, it was appreciated that unexpected factors might cause degradation and that an important result from this experiment would certainly be an evaluation of the lifetime of the toluene working fluid.

During repair and maintenance operations performed while the unit was under initial tests, samples of toluene were taken and analyzed at JPL. It was found that a small quantity (0.05%) of aliphatic hydrocarbon and phthalate ester were present and that the toluene was discolored.

It was suspected that vacuum-pump oil might be contaminating the sample (the system is pumped down as part of the filling operation), so a cold trap was installed in the line. A sample taken at the conclusion of the test was clear and had only 0.004% residue of phthalate and polyglycol, suggesting that the source of the contaminant had indeed been the vacuum-pump oil. It was also decided that the material used for accumulator bladders might have contained plasticizers that were another potential source of contamination. Although the degradation problem seems to have been eliminated, future ORC work should always be conducted with careful consideration and measurement of the purity of the working fluid during the course of the experiments.

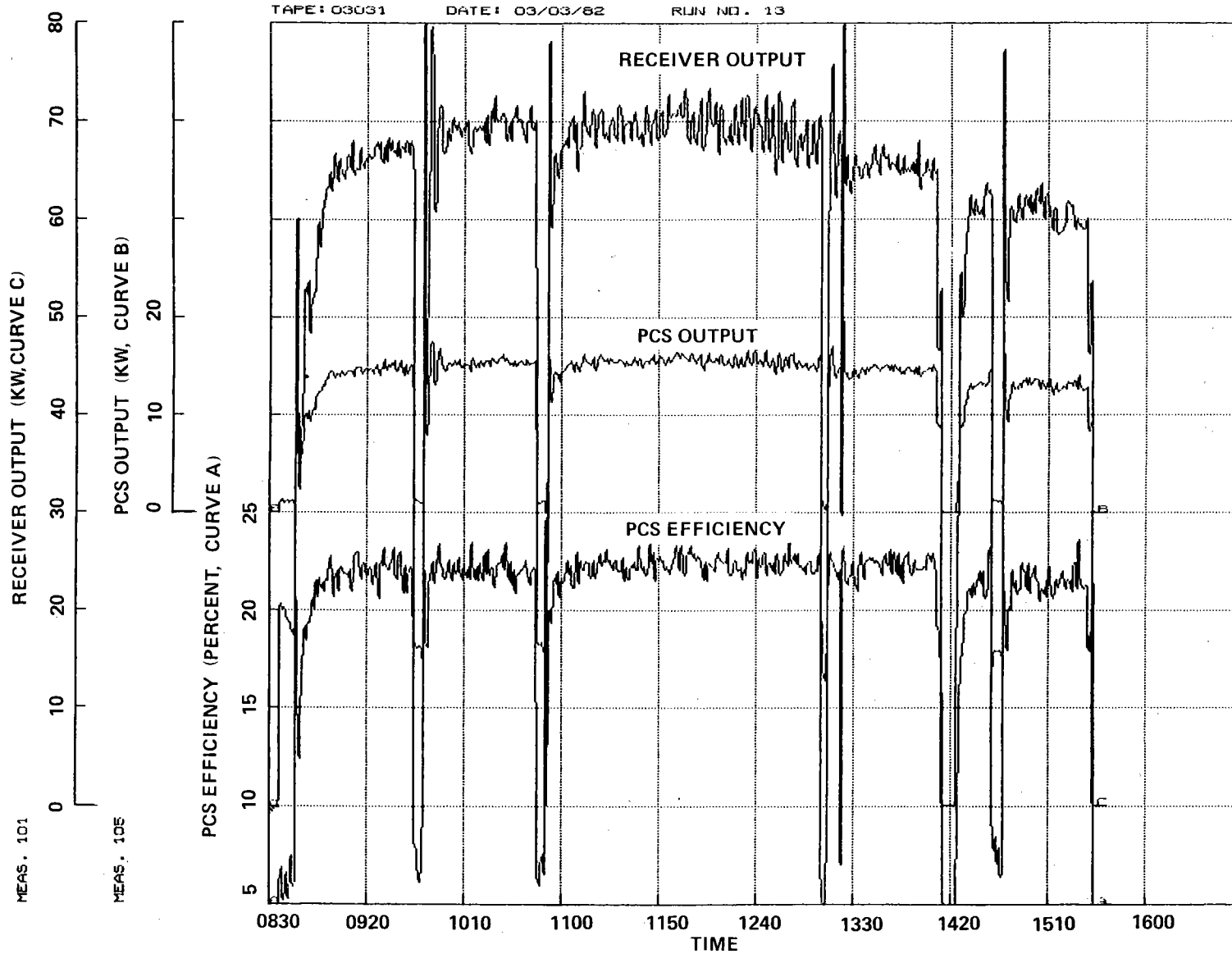

Figure 4-9. Power-Conversion Subsystem Performance History for Run 13 (Test No. 8)

Table 4-4. Power-Conversion Subsystem Test Data at Parabolic Dish Test Site

Run No. (Date)	Time	Power to PCS, PM4 (kW <sub>r</sub> )	Gross Power Out, PM5 (kW <sub>e</sub> )	Net PCS Power Out* (kW <sub>e</sub> )	Net PCS Eff.	Fan Spd.	dc Volts	Mask. (%)	Amb. Temp (°F)
8 (2-25)	09:46	58.0	12.7	12.0	20.7	HI	500	0	52
9 (2-25)	14:00	67.0	14.0	13.6	20.3	LO	500	0	66
11 (2-26)	12:10	72.0	16.0	15.3	21.3	HI	500	0	62
	13:32	55.5	11.2	10.5	18.9	HI	500	0	68
13 (3-03)	10:50	69.0	15.3	14.6	21.2	HI	500	0	54
	12:00	70.4	16.2	15.5	22.0	HI	500	0	55
	13:55	65.0	15.0	14.3	22.0	HI	500	0	54
	14:50	61.5	13.2	12.5	20.3	HI	500	0	53
17 (3-18)	09:36	66.4	14.5	13.8	20.8	HI	500	0	45
18 (3-19)	12:30	36.5	5.0	4.6	12.7	LO	500	50	51
	12:50	36.5	5.0	4.3	11.8	HI	500	50	52
	13:30	35.0	4.0	3.3	9.5	HI	550	50	52
19 (3-19)	15:28	47.5	8.5	7.8	16.5	HI	500	25	53
20 (3-22)	12:18	52.7	10.8	10.1	19.2	HI	500	25	60
	13:00	34.5	4.7	4.3	12.5	LO	500	25	60
	13:05	42.0	7.0	6.6	15.8	LO	500	25	60
	13:15	51.0	9.2	8.8	17.3	LO	500	25	61
	13:56	16.5	1.3	0.6	3.7	HI	500	25	60
	14:40	49.5	9.0	8.3	16.8	HI	550	25	61

\*Net Power = PM5 minus parasitics



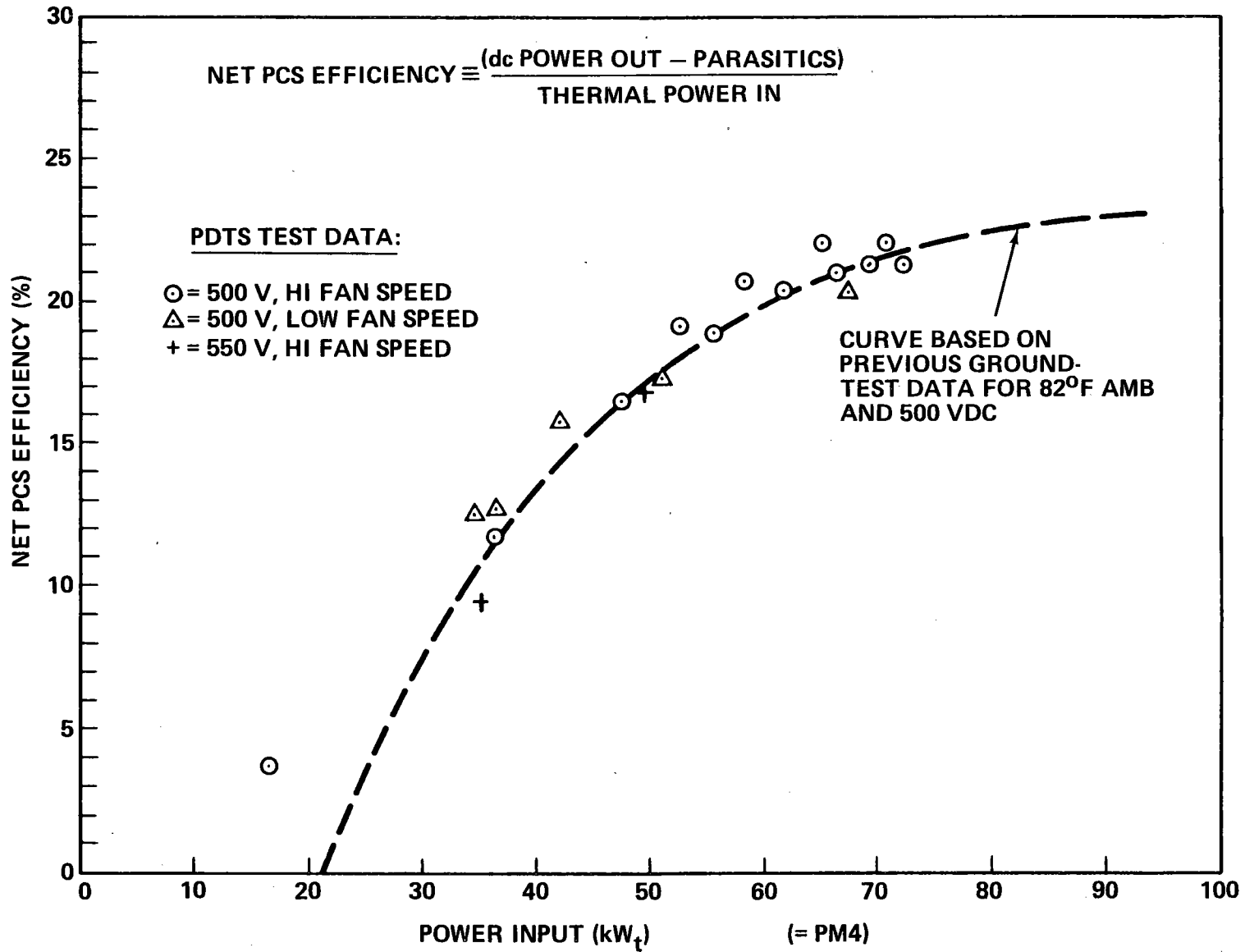

Figure 4-10. Measured ORC Engine Efficiency (Net after Parasitic Power Subtracted)

## 5. The Energy Transport System

Although the energy transport system includes items like the switchboard, cabling, and junction boxes, the inverter is the key element. Not only does it change the generated dc into grid-compatible, 60-Hz, three-phase power, but it also serves as the control voltage reference that controls the turbine-alternator power output.

Initial tests made use of the load bank that was installed at the PDTS especially for this test series. The resistance elements in the bank provide a means of dissipating the power generated by the module in the event of failure of the grid or of electrical connecting lines leading to the grid. It also provides a known and stable load during the start-up sequence, during which time the output of the module is below the level acceptable to the grid. Switching between the load bank and the grid is done by the switchboard, which performed this function satisfactorily during these tests.

The inverter also performed well after it was repaired, but it had not been completely qualified by the completion of the test series. Table 4-5, (see Reference 4-2), lists the requirements placed on the inverter and shows the degree of success achieved in meeting these requirements. The efficiency of the inverter, like that of the other energy-handling subsystems, is important in establishing the economic value of the plant. In general, the efficiency of inverters increases significantly with size, especially in the smaller size ranges. The actual measured performance of the inverter is compared to the predicted value in Figure 4-11. Several features of this plot should be noted:

- (1) Although the maximum output of the module as tested was 16.2 kWe, the inverter was rated at 30 kWe. Because the energy consumption is size-dependent, there is a definite penalty associated with using an inverter that is larger than required and thus operating at part load. On the other hand, it was considered necessary to demonstrate the capability of the energy transport subsystem to operate in the multi-module mode. This capability was demonstrated by operating the module in parallel with a dc power supply so that the combined output of the dish (on-sun) and the dc power supply (drawing from the laboratory utility supply) was within 3 kWe of the rated capacity of the inverter. This power was fed to the Edwards Air Force Base power grid, a part of the Southern California Edison distribution system.
- (2) By throwing the switch on the dc power supply, it was possible to study the effect on the control system of an additional simulated power module starting up or dropping out while connected in parallel with the module under test. The response of the control system to these perturbations was essentially instantaneous, with no indication of mutual influence between the active power module and the dc power supply.

Table 4-5. Inverter Requirements

<u>Requirements</u>	<u>Test Results/Achievements</u>	<u>Comments</u>
<p><u>MAJOR:</u></p> <ol style="list-style-type: none"> <li>1. Produce grid-compatible ac power and ac power and ac power to load bank</li> <li>2. Maintain input voltage within 2% (load control for turbine/alternator)</li> <li>3. Operate with input voltages between 500 and 630V</li> <li>4. Operate over a power range from 0 to 30 kVA</li> </ol>	<ul style="list-style-type: none"> <li>● Load bank operation ok</li> <li>● Grid operation (Run 21) ok until idle condition or reverse current reached</li> <li>● Requirement met, voltage normally held within <math>+5V</math> (<math>+1\%</math>) for steady state operation</li> <li>● Requirement met, some operation as low as <math>\sim 475V</math> and as high as 601V (high voltage run at ATC)</li> <li>● Requirement met for all levels up to maximum available (26.8 kW)</li> </ul>	<ul style="list-style-type: none"> <li>● Control circuit to be modified to switch to load bank when reverse current sensed</li> <li>● Width of voltage band adjustable in inverter</li> <li>● Voltage setting adjustable. Tap on output transformer now set on lower range</li> <li>● Unit should be operational to 40 kVA according to Nova</li> </ul>
<p><u>OTHER REQUIREMENTS:</u></p> <ol style="list-style-type: none"> <li>5. Input voltage ripple less than 5%; input current ripple less than 1%</li> <li>6. Input and power source impedance (Para. 3.6.1.5 of Ref. 3-12)</li> <li>7. Output power factor of <math>0.95 \pm 0.05</math></li> <li>8. Output voltage: <math>480 \pm 48V</math> to grid</li> </ol>	<ul style="list-style-type: none"> <li>● Believed to be acceptable, but a function of the rectifier, not the inverter</li> <li>● Acceptable; input impedance = <math>15.7 \pm 0.2</math> ohms</li> <li>● Believed to be acceptable, but low voltage setting affects P.F.</li> <li>● Acceptable in Run 21; voltage to load bank not a requirement</li> </ul>	<ul style="list-style-type: none"> <li>● Future measurements planned</li> <li>● Future measurements planned</li> <li>● Future measurements planned</li> <li>● Future measurements planned</li> </ul>

Table 4-5. (Cont'd)

<u>Requirements</u>	<u>Test Results/Achievements</u>	<u>Comments</u>
9. Output distortion and regulation (Para. 3.2.6.5, 3.2.6.6 of Ref. 3-12)	<ul style="list-style-type: none"> <li>● Acceptable in grid test (Run 21)</li> </ul>	<ul style="list-style-type: none"> <li>● Future measurements planned</li> </ul>
10. Efficiency: greater than 80% at power levels between 10-20 kVA	<ul style="list-style-type: none"> <li>● Acceptable, test data shown in Figure 4-11</li> </ul>	<ul style="list-style-type: none"> <li>● Low input voltage (~500V) increases losses compared to design voltage of 600V</li> </ul>
11. Protective circuitry, test circuits, controls, and switch contacts (Para. 3.6.4-3.6.6 of Ref. 3-12)	<ul style="list-style-type: none"> <li>● Generally acceptable for normal operation; circuit modifications identified for grid-connected mode</li> </ul>	<ul style="list-style-type: none"> <li>● Reliability of circuits/components needs improvements</li> </ul>

#### 6. Overall System Performance

The performance of the overall system was measured using the data obtained at the Test Site and computed and plotted by the OPWEG program (see Reference 4-3). The following account, taken from that reference, gives an in-depth look at a specific representative run (No. 14, test No. 8) and shows how it was calculated and presented. This same run forms the body of Appendix B (also from Reference 4-3), which shows how the data were recorded and tabulated.

The individual component and subsystem efficiencies and performance obtained during the verification tests have been combined to yield "module" and "overall" values. The term "module" refers to the power out of the PCS, i.e., module efficiency is PCS power out (PM5 in program OPWEG) divided by the power available to the concentrator. "Overall" or "system" refers to the power out of the inverter (PM6); thus, overall efficiency is PM6 divided by available power to the concentrator.

The example selected as representative of a typical steady-state condition was Run 13 (Test No. 8) at 12:00 noon. This test was conducted on March 3, 1982, and had a total run time of 6.7 h. A data printout for a short period after noon for Run 13 is given in Appendix B, and sample plots are given in Figures 4-7 and 4-8. The insolation from the Eppley pyrhelimeter at 12:00 was 983 W/m<sup>2</sup>, but insolation available for focusing was 3.5% less, due

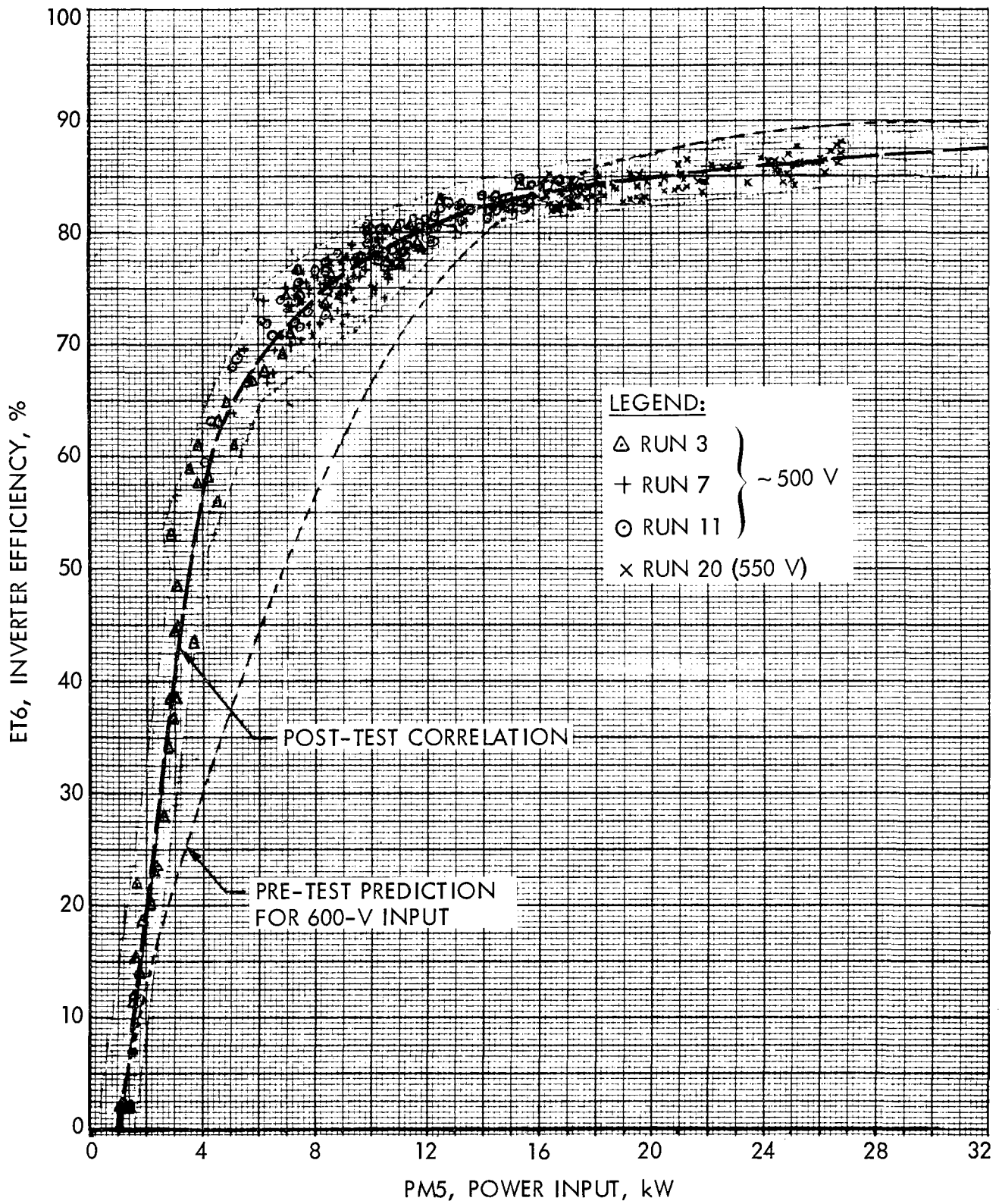

Figure 4-11. Inverter Efficiency Data and Pre-Test Predictions

to the average circumsolar effect.<sup>11</sup> Thus, the power available for focusing was

$$(983)(0.965)(87.6)/1000 = 83.1 \text{ kW}$$

where the term 87.6 is the effective area of the concentrator in square meters. The value of 83.1 kW is the first step on a waterfall-type performance chart in Figure 4-12. This figure also shows the efficiency of the individual components and subsystems. The values used were primarily obtained from the output of program OPWEG (see Appendix B, Table B-1) by the techniques summarized below; additional details are contained in Reference 4-4.

- (1) The efficiency of the concentrator was calculated as the product of the reflectivity, dust, and blockage factors. The updated blockage ratio of 0.967 was used.
- (2) The receiver efficiency was obtained by averaging the "measured" efficiency from the program printout (EMR<sup>12</sup>) over a period of about 30 s before and after noon.
- (3) The PCS and inverter efficiencies (EM5 and EM6 in program OPWEG) were obtained by averaging the outputs from the program over the intervals described above.

Numbers in parentheses in Figure 4-12 refer to net values; that is, they have accounted for the PCS parasitic power of 0.68 kWe for high-speed fan conditions. For example, the module efficiency for the conditions noted was 19.5% measured or gross, or 18.7% net. The module (PCS) power output was 16.2 kWe gross or 15.5 kWe net.

The overall or system efficiency was 15.5% (net) or three points less than that for the module due to the losses through the inverter (83.3% efficient). As described previously, the inverter was a subscale unit (30 kVA, rated) and operated at an input dc voltage for this test of 500 V, compared to a design value of 600 V. Both of these factors reduce the efficiency that could be obtained with a larger unit operating at a higher voltage.

Figure 4-10 also shows that all components in Test 13 were operating well below design power levels even though the insolation was only about 10% below the peak rated value (983 vs. 1100 W/m<sup>2</sup>). The primary reason for the relatively low power output was that the TBC is not large enough to provide

---

<sup>11</sup>See Section IV D-1 for comment on the legitimacy of using this assumption.

<sup>12</sup>The values for EM4 in Table B-1 (Appendix B) must be increased by 5.5% to correct for the erroneous value for the concentrator effective area that had been used until Run 16.

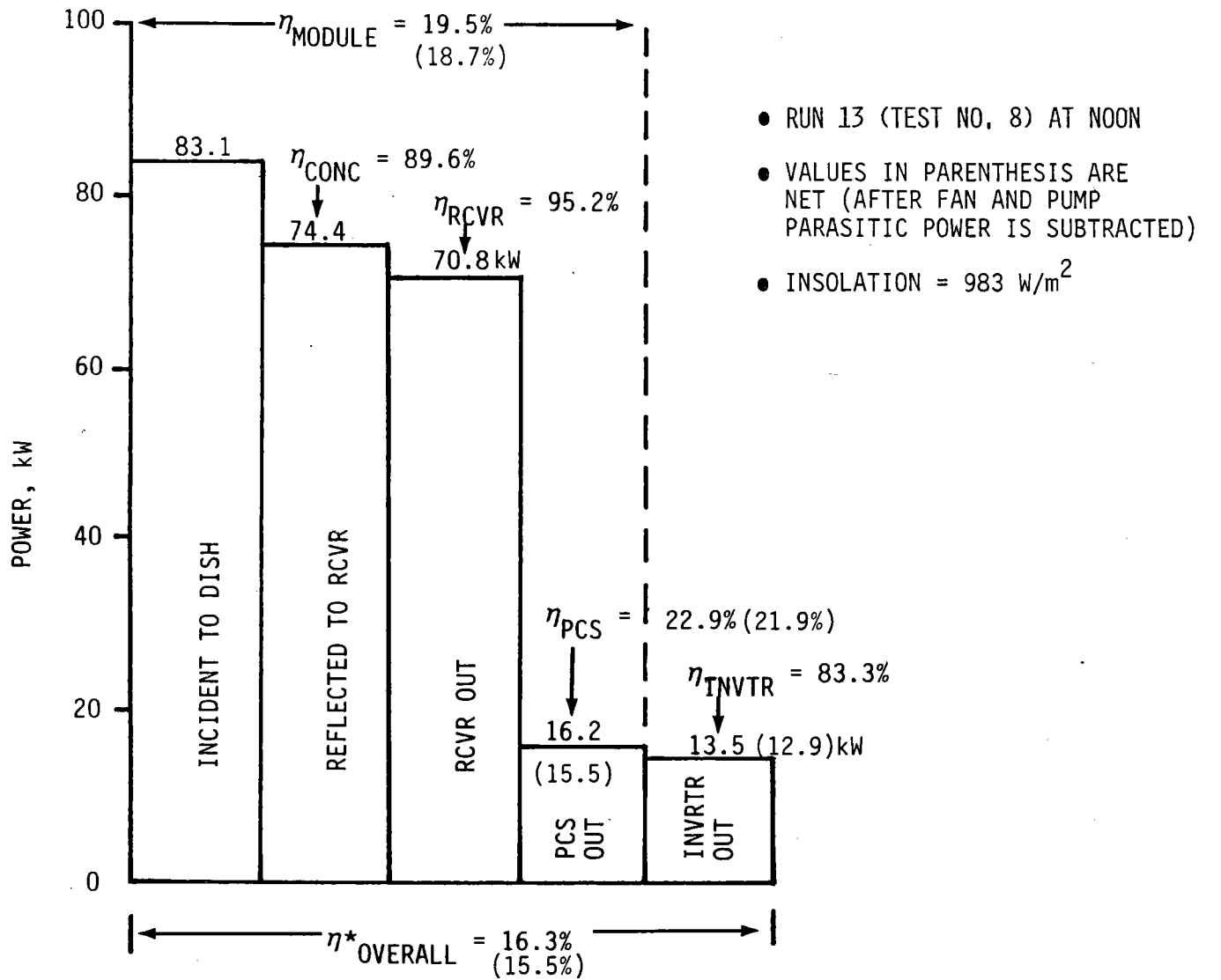

- RUN 13 (TEST NO. 8) AT NOON
- VALUES IN PARENTHESIS ARE NET (AFTER FAN AND PUMP PARASITIC POWER IS SUBTRACTED)
- INSOLATION = 983 W/m<sup>2</sup>

\*INCLUDES SUBSCALE INVERTER

Figure 4-12. Measured Component, Module, and System Performance for a Typical Run

the design power inputs and, thus, the higher component efficiencies associated with them. The following comparisons illustrate this fact.

---

Component/Subsystem	Input Power for Run	Design Input Power
Receiver	74.4 kWt	95 kWt
PCS	70.8 kWt	92.4 kWt
Inverter	16.2 kWe	30 kVA rated, 40 kVA peak

---

As seen in this comparison, the PCS was operating about 30% below the design power level and is the component that is most sensitive to part-load performance penalties. Therefore, the 22 to 23% efficiency of the PCS for this run is not unexpected, especially when the off-design considerations are included.



## SECTION V

### CONCLUSIONS AND RECOMMENDATIONS

Although this program did not realize its intended ambitious goal of placing a 1-MWe, solar-thermal power plant into operation in a small community environment, it did achieve some significant accomplishments. Before the program started it was assumed that a small, Rankine-cycle power conversion unit was virtually an "off-the-shelf" item. It was soon evident, however, that no unit actually existed that was suitable for the intended application. To meet this need, a small, dish-mounted, ORC power-conversion assembly was developed, which satisfied all of the important functional requirements and which met initial performance specifications. The effect of this milestone achievement is to provide a baseline ORC power-conversion design that can be modified or improved to provide candidate receivers and engines for future terrestrial as well as space solar and non-solar applications. The same can also be said for the control and energy transport systems as they were developed for use with the chosen ORC and its associated electrical-generation and conditioning systems.

The concentrator developed under this program has not been fabricated, so it would be premature to announce its suitability for other potential uses, or even to predict its performance. The drawings and specifications are a part of the public domain, however, and they can be used as resource material by others facing the problem of developing a high-performance parabolic dish concentrator.

On the basis of actual measured performance the following conclusions can be drawn:

- (1) An efficient, successful power-conversion subsystem with the potential of excellent lifetime has been made for solar point-focusing applications, using toluene as the working fluid in an hermetically sealed, turbine-driven engine.
- (2) The receiver problem for the solar-powered toluene receiver has been solved by using a single-pass, stainless steel tube wrapped around the outside of a cylindrical copper shell.
- (3) High quality, grid-compatible electric power has been produced by a plant using a control-type inverter to process the rectified output of many semi-independent modules.
- (4) A plant control system has been designed that promises to be capable of fully unattended operation.

These conclusions, if combined with other lessons learned during this program, suggest that the following efforts be continued in the future:

- (1) The units designed and fabricated under this program should continue to be tested and operated for long periods to discover any latent problems that remain undiscovered. The highly developed control system should be assembled and used in future tests.

- (2) Follow-on units should be built and tested that incorporate some of the design changes suggested by measured test results. These include:
- (a) Changes in the nozzle profiles to provide a better match with the measured back pressure. The present nozzles over-expand the toluene vapor, probably resulting in unnecessary shock losses.
  - (b) Improve the efficiency of the regenerator by modifying the design of the nozzle exit shroud so that a "dead" zone does not exist in the center of the regenerator heat exchanger.
  - (c) Increase the diameter of the alternator to improve the geometry of the magnetic path.
  - (d) Perform tests on the feed pump to determine and, if possible, improve its efficiency.
  - (e) Modify the configuration of the TAP housing to permit final assembly without having first to dismantle the rotor components (and thereby introducing the chance of reassembling it in an unbalanced condition).
  - (f) Conduct life tests on the improved TAP unit, using a cost-effective semi-automated test stand.
  - (g) Conduct studies to examine production techniques and material studies to reduce the cost of the organic Rankine-cycle power-conversion assembly.

## REFERENCES

- 1-1. Phase 1 of the First Small Power System Experiment (Engineering Experiment No. 1), Final Report No. MDC G7833, Vol. I through V, McDonnell Douglas Corporation, Huntington Beach, California, May 1979.
- 1-2. Phase 1 of the First Small Power System Experiment (Experimental System No. 1), Vol. I, General Electric Company, Energy Systems Programs Department, May 1979.
- 1-3. Phase 1 of the First (Solar) Small Power System Experiment (Experimental System No. 1), Final Report No. U-6529, Ford Aerospace and Communications Corporation, Newport Beach, California, May 5, 1959.
- 2-1. Bland, T. (Sunstrand Corporation), 15-kWe (Nominal) Solar Thermal Electric Power Conversion Concept Definition Study - Steam Rankine Turbine System, Final Report DOE/NASA/0061-79/1, NASA CR-159589, AER 1713, October 1979.
- 2-2. Fuller, H., Demler, R., Paulin, E. and Dantowitz, P. (Foster-Miller Associates, Inc.), 15-kWe (Nominal) Electric Power Conversion Concept Definition Study - Steam Rankine Reheat Reciprocator System, Final Report DOE/NASA/0062-79/1 NASA CR-1595909, June 1979.
- 2-3. Wingenbach, W., and Carter, J. (J. Carter Enterprises), 15-kWe (Nominal) Solar Thermal-Electric Power Conversion Concept Definition Study - Steam Rankine Reciprocator System, Final report DOE/NASA/0063-79/1 NASA CR-159591, June 1979.
- 2-4. Clark, T.B., Prime Item Specification for the Small Community Solar Thermal Power Experiment (SCSE), Phase III, Ford Aerospace and Communications Corporation, AS 2001116 (Draft), August 3, 1983.
- 3-1. Dennison, E.W., and Thostensen, T., Development and Testing of Parabolic Dish Concentrator No. 1, JPL Publication 85-4, Jet Propulsion Laboratory, Pasadena, California, December 15, 1984.
- 3-2. Clark, T.B., Critical Item Development Specification for the Parabolic Dish Concentrator-2 (PDC-2), Ford Aerospace and Communications Corporation, AS2001185, September 16, 1983.
- 3-3. Marciavak, T.J., et al; Comparison of Rankine-Cycle Power Systems: Effects of Seven Working Fluids, Arizona National Laboratory, ANL/CNSV-TM-87, June 1981.
- 3-4. Clark, T.B., and Boda, F.P., Critical Item Product Specification - SCSE Power Conversion Subsystem (PCS), Ford Aerospace and Communications Corporation, AS2001378, August 29, 1983.
- 3-5. Campanaro, L., Brazing and Finishing of Copper Solar Receiver, Ford Aerospace and Communications Corporation, APS 149487, February 4, 1981.

- 3-6. Haskins, J.J., Taylor, R.M., and Osborn, D.B., "Development of a Solar Receiver for an Organic Rankine-Cycle Engine," Paper No. 819750, Presented at the 16th Intersociety Energy Conversion Engineering Conference, Atlanta, Georgia, August 9-14, 1981.
- 3-7. Osborne, D.B., and Conway, W.A., Test Results for the Development Receiver Core, Ford Aerospace and Communications Corporation, TR No. SCSE-042, June 9, 1981.
- 3-8. Osborn, D.B., Test Report Receiver Qualification Tests, Ford Aerospace and Communications Corporation, SCSE Report No. 015, August 6, 1981.
- 3-9. Pons, R.L., "Development Status of the Small Community Solar Power System," Proceedings of the Parabolic Dish Solar Thermal Power Annual Review, Atlanta, Georgia, December 1981. JPL Publication 82-66.
- 3-10. Barber, R.E., and Boda, F.P., "Organic Rankine Power Conversion Subsystem Development for the Small Community Solar Thermal Power System," Proceedings of the Parabolic Dish Solar Thermal Power Annual Review, Atlanta, Georgia, December 1981. JPL Publication 82-66.
- 3-11. Nesmith, B., Bearing Development Program for a 25-kWe, Solar-Powered Organic Rankine-Cycle Engine, JPL Report 5105-146, Jet Propulsion Laboratory, Pasadena, California, March 15, 1985.
- 3-12. Bergthold, F., and Garrigus, W., Inverter Control Methods and PCS Electrical Matching Characteristics, Ford Aerospace and Communications Corporation, TR No. SCSE-014, September 15, 1980.
- 3-13. Garrigus, W.E., Performance Specification for a 30-KVA Inverter, Ford Aerospace and Communications Corporation, AS147633, March 21, 1981.
- 3-14. Fulton, D.G., "Control System Development for the Small Community Solar Power System," Proceedings of the Fourth DOE Parabolic Dish Solar Thermal Power Program Review, Pasadena, California, December 1, 1982.
- 4-1. Selcuk, M.K., Parabolic Dish Test Site: History and Operating Experience, JPL Report 5105-147, Jet Propulsion Laboratory, Pasadena, California, January 15, 1985.
- 4-2. Clark, T.B., Power Conversion Assembly Verification Test on the TBC and Energy Transport Subsystem Qualification, Ford Aerospace and Communications Corporation, SCSE Report No. 023, April 23, 1982.
- 4-3. Clark, T.B., Power/Energy/Efficiency Calculations for the TBC PDTS - Program OPWEG, Ford Aerospace and Communications Corporation, TR SCSE-044A, January 29, 1982, Revised April 8, 1982 (TR SCSE-044B).
- 4-4. Osborn, D.B., Haskins, H.J., Conway, W.A., and Wan, C.C., "Design and Test of a Solar Receiver for an Organic Rankine Cycle Engine," ASME Solar Energy Conference, Albuquerque, New Mexico, April 26-30, 1982.
- 4-5. Qualification Test for the PCS, Barber-Nichols Engineering, November 1981.

## APPENDIX A

### THE CARTER ENGINE

Although toluene was selected for use in the proposed engine, there remained sufficient uncertainty about its expected life at the time it was selected to warrant consideration of a back-up engine using a different working fluid. After exploring the availability of alternative engines, it was determined that only the Carter steam reciprocator expander engine satisfied requirements of size and efficiency and actually existed as hardware (Figure A-1). To verify the functional and performance characteristics of the Carter engine, Jay Carter Enterprises was awarded a contract to conduct a series of tests<sup>1</sup> on its two-cylinder, paratransit vehicle engine at a branch office in California. For these tests (Figure A-2) the steam source consisted of the automotive steam generator unit designed and built for that engine and a 25-hp, three-phase induction alternator to absorb the power. The electric power that was produced was fed into the Santa Barbara distribution grid of the Southern California Edison Company. A brief description and summary of results is shown in Table A-1.

Table A-1. Carter Steam Engine Specifications

---

Model:	Paratransit Vehicle Engine
Type:	Two-Cylinder, Single-Acting Uniflow
Bore:	2.5 in.
Stroke:	3 in.
Displacement:	29.54 in. <sup>3</sup>
Expansion Ratios:	10:1 14.4:1
Speed:	3600 rev/min
Nominal Power Rating:	23.09 hp (at 1000°F, 10:1 Expansion Ratio)

---

70115-

---

<sup>1</sup>For a description of these tests, see W.J. Wingenbach, Evaluation of Carter Reciprocator Steam Engine, Final Report, FACC P.O. G23581, Jay Carter Enterprises, Inc., May 1981; and Wingenbach, W.J., and Kiceniuk, T., "Recent Tests on the Carter Small Reciprocating Steam Engine," JPL Parabolic Dish Solar Thermal Power Annual Program Review, Atlanta, Georgia, December 8-10, 1981; JPL Publication 82-66.

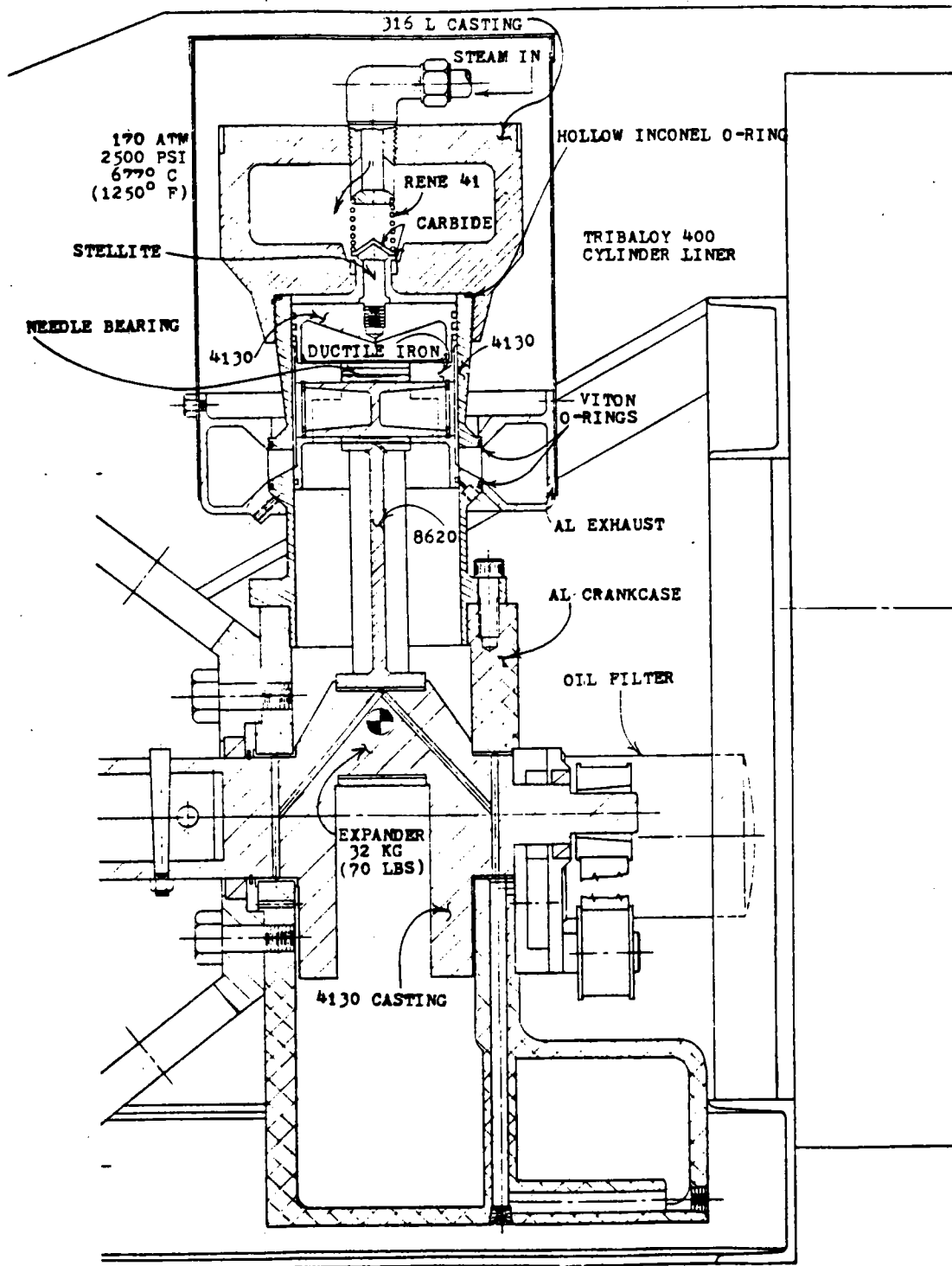

Figure A-1. Cross Section Drawing of a Proposed Carter Single-Cylinder Engine Similar to the Two-Cylinder Unit Tested as Part of the Study in this Report

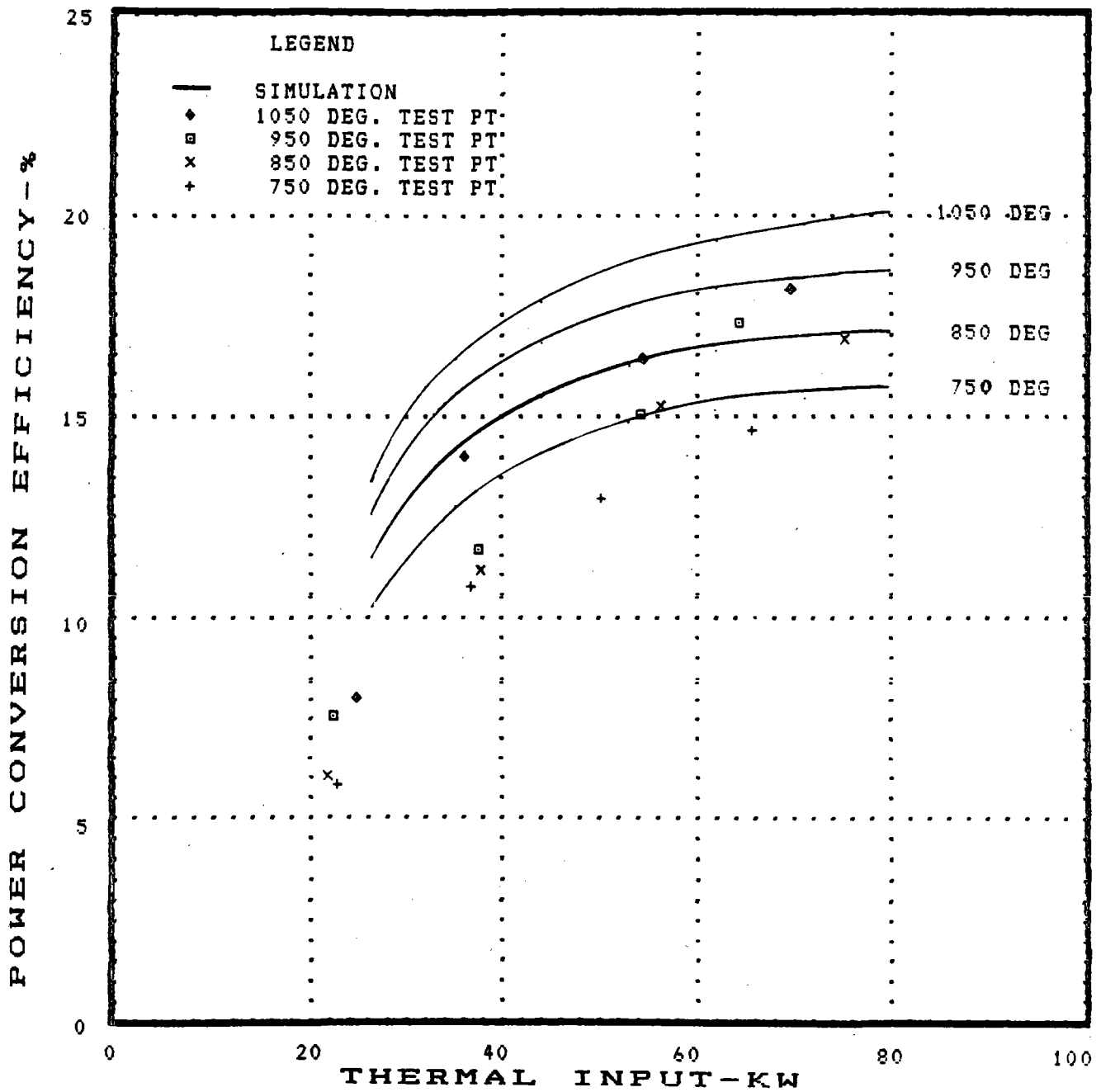

Figure A-2. Comparison of Test Results with Calculated Predictions for Jay Carter Enterprises Two-Cylinder Steam Engine

## APPENDIX B

### SAMPLE PRINTOUT OF ALL DISPLAYS

The following pages contain reduced copies of the complete printout record for a short (~1 minute) test period at noon for Run 13 (Test No. 8). This run was selected as being representative of a steady-state, normal operating condition.

Each printout is preceded by a page which contains a description of each heading. All printouts have the identical first three columns: time (self explanatory), RCIA data link status (RLS) and weather data link status (WLS). A value of zero for RLS and WLS is normal; a value of 1 would indicate a failure in the link.

The list of the printouts corresponds to that contained in Paragraph 3.4, i.e., display No. 1 is printed as Print 01. Since the number of columns on the printer is limited, each display is divided into two separate printed pages, e.g., Print 01 left (01L) and 01 right (01R). The display/print summary is given below.

<u>Print No.</u>	<u>Display No.</u>	<u>Title</u>	<u>Table No.</u>
01L and R	1	Power and Energy, Program OPWEG	B-1
02L and R	2	PCA Temps and Pressures	B-2
03L and R	3	Other PCA Measurements	B-3
04L and R	4	PCS Events (Discrettes)	B-4
05L and R	5	ETS Data	B-5
06L and R	6	Weather Data	B-6
-	7	TBC Data (Not implemented)	-
08L and R	8	PCS Performance Data	B-7



PRINT 01 DESCRIPTION - POWER AND ENERGY

<u>Print No.</u>	<u>Parameter</u>	<u>Description*</u>
01L	PM1	Local Eppley pyrhelimeter reading
01L	PT2**	PM1 corrected for circumsolar effects, i.e. flux available to concentrator
01L	E2	Energy available to concentrator
01L	PT3	Power available to receiver (theoretical)
01L	PT4	Power available to PCS (theoretical)
01L	PM4	Power available to PCS (measured value derived from mass flow and enthalpy rise)
01L	ET4	Efficiency of receiver (theoretical)
01L	EM4***	Efficiency of receiver (calculated)
01L	PT5	Power out of PCS (theoretical)
01L	PM5	Power out of PCS (measured)
-----		
01R	ET5	Efficiency of PCS (theoretical)
01R	EM5**	Efficiency of PCS (measured)
01R	PT6	Power out of inverter (theoretical)
01R	PM6	Power out of inverter (measured)
01R	E6	Energy out of inverter
01R	ET6	Efficiency of inverter (theoretical)
01R	EM6	Efficiency of inverter (measured)
01R	OEP**	Efficiency of module based on input and output power
01R	OEE**	Efficiency of module based on input and output energy

\*See TR-SCSE-044A for an explanation of the equations used for the Power and Energy calculations (Ref. B-1).

\*\*The definition of these parameters has changed slightly in the latest version of program OPWEG (see TR-SCSE-044B). The 'A' version of the program was used for the tests reported here.

\*\*\*The value of EM4 for Run 13 and all runs prior to 16 were low due to incorrect area for concentrator. Add 5.5% to value printed to obtain correct number, i.e. 89.9 becomes 95.4.

Table B-1. Printout of 01 for Run 13

PRINT: 01L

FACC SMALL COMMUNITY SOLAR EXPERIMENT  
DATE: 03/03/82

PAGE: 0001

TIME	RLS	WLS*	PM1 W/M*M	PT2 W/M*M	E2 KWH	PT3 KW	PT4 KW	PM4 KW	ET4 PERCENT	EM4 * PERCENT	PT5 KW	PM5 KW
12:00:00	0	0	0982.8	0948.4	0280.6	0078.7	0076.8	0070.8	0097.5	0089.9	0016.4	0016.2
12:00:01	0	0	0982.9	0948.1	0280.7	0078.7	0076.8	0072.2	0097.5	0091.7	0016.8	0016.3
12:00:02	0	0	0982.8	0948.4	0280.7	0078.7	0076.8	0071.2	0097.5	0090.4	0016.5	0016.4
12:00:03	0	0	0982.8	0948.4	0280.7	0078.7	0076.8	0071.1	0097.5	0090.2	0016.5	0016.1
12:00:04	0	0	0982.8	0948.4	0280.7	0078.7	0076.8	0071.0	0097.5	0090.2	0016.4	0016.1
12:00:05	0	0	0982.5	0948.1	0280.8	0078.7	0076.8	0071.8	0097.5	0091.1	0016.7	0016.0
12:00:06	0	0	0982.5	0948.1	0280.8	0078.7	0076.8	0071.1	0097.5	0090.3	0016.5	0016.1
12:00:07	0	0	0982.8	0948.4	0280.8	0078.7	0076.8	0071.2	0097.5	0090.4	0016.5	0016.2
12:00:08	0	0	0983.4	0948.9	0280.8	0078.8	0076.9	0071.2	0097.5	0090.4	0016.5	0016.2
12:00:09	0	0	0983.1	0948.6	0280.9	0078.8	0076.9	0071.2	0097.5	0090.3	0016.5	0016.3
12:00:10	0	0	0983.4	0948.9	0280.9	0078.8	0076.9	0071.8	0097.5	0091.1	0016.7	0016.2
12:00:11	0	0	0982.8	0948.4	0280.9	0078.7	0076.8	0071.2	0097.5	0090.3	0016.5	0016.2
12:00:12	0	0	0982.8	0948.4	0280.9	0078.7	0076.8	0072.3	0097.5	0091.8	0016.8	0016.3
12:00:13	0	0	0982.5	0948.1	0281.0	0078.7	0076.8	0071.3	0097.5	0090.5	0016.5	0016.2
12:00:14	0	0	0983.1	0948.6	0281.0	0078.8	0076.9	0071.1	0097.5	0090.2	0016.4	0016.1
12:00:15	0	0	0982.5	0948.1	0281.0	0078.7	0076.8	0071.1	0097.5	0090.3	0016.5	0016.0
12:00:16	0	0	0982.8	0948.4	0281.0	0078.7	0076.8	0071.0	0097.5	0090.1	0016.4	0016.2
12:00:17	0	0	0982.8	0948.4	0281.1	0078.7	0076.8	0071.8	0097.5	0091.1	0016.7	0016.1
12:00:18	0	0	0983.1	0948.6	0281.1	0078.8	0076.9	0071.2	0097.5	0090.3	0016.5	0016.0
12:00:19	0	0	0982.8	0948.4	0281.1	0078.7	0076.8	0071.1	0097.5	0090.3	0016.5	0016.0
12:00:20	0	0	0982.8	0948.4	0281.1	0078.7	0076.8	0069.7	0097.5	0088.5	0016.0	0016.4
12:00:21	0	0	0982.8	0948.4	0281.2	0078.7	0076.8	0071.9	0097.5	0091.3	0016.7	0016.1
12:00:22	0	0	0983.1	0948.6	0281.2	0078.8	0076.9	0071.2	0097.5	0090.4	0016.5	0016.4
12:00:23	0	0	0982.8	0948.4	0281.2	0078.7	0076.8	0071.8	0097.5	0091.2	0016.7	0016.3
12:00:24	0	0	0983.1	0948.6	0281.2	0078.8	0076.9	0070.9	0097.5	0089.9	0016.4	0016.1
12:00:25	0	0	0983.1	0948.6	0281.3	0078.8	0076.9	0072.1	0097.5	0091.5	0016.8	0016.1
12:00:26	0	0	0983.4	0948.9	0281.3	0078.8	0076.9	0071.3	0097.5	0090.4	0016.5	0016.3
12:00:27	0	0	0983.7	0949.2	0281.3	0078.8	0076.9	0070.4	0097.5	0089.3	0016.2	0016.3
12:00:28	0	0	0983.7	0949.2	0281.3	0078.8	0076.9	0071.3	0097.5	0090.5	0016.5	0016.2
12:00:29	0	0	0983.4	0948.9	0281.3	0078.8	0076.9	0071.0	0097.5	0090.1	0016.4	0016.4
12:00:30	0	0	0983.7	0949.2	0281.4	0078.8	0076.9	0070.6	0097.5	0089.6	0016.3	0016.2
12:00:31	0	0	0984.0	0949.5	0281.4	0078.8	0076.9	0071.2	0097.5	0090.3	0016.5	0016.2
12:00:32	0	0	0984.0	0949.5	0281.4	0078.8	0076.9	0071.4	0097.5	0090.5	0016.5	0016.1
12:00:33	0	0	0983.7	0949.2	0281.4	0078.8	0076.9	0070.9	0097.5	0089.9	0016.4	0016.1
12:00:34	0	0	0983.7	0949.2	0281.5	0078.8	0076.9	0071.1	0097.5	0090.1	0016.4	0016.2
12:00:35	0	0	0983.7	0949.2	0281.5	0078.8	0076.9	0071.2	0097.5	0090.2	0016.5	0016.4
12:00:36	0	0	0983.7	0949.2	0281.5	0078.8	0076.9	0072.5	0097.5	0091.9	0016.9	0016.0
12:00:37	0	0	0985.2	0950.7	0281.5	0078.9	0077.0	0071.9	0097.5	0091.1	0016.7	0016.1
12:00:38	0	0	0984.9	0950.4	0281.6	0078.9	0077.0	0071.4	0097.5	0090.4	0016.5	0016.5
12:00:39	0	0	0984.6	0950.1	0281.6	0078.9	0077.0	0071.1	0097.5	0090.1	0016.4	0016.8
12:00:40	0	0	0984.9	0950.4	0281.6	0078.9	0077.0	0072.5	0097.5	0091.9	0016.9	0016.1
12:00:41	0	0	0984.9	0950.4	0281.6	0078.9	0077.0	0072.6	0097.5	0092.0	0016.9	0016.3
12:00:42	0	0	0984.9	0950.4	0281.7	0078.9	0077.0	0071.4	0097.5	0090.4	0016.5	0016.7
12:00:43	0	0	0984.3	0949.8	0281.7	0078.9	0077.0	0071.3	0097.5	0090.4	0016.5	0016.2
12:00:44	0	0	0984.6	0950.1	0281.7	0078.9	0077.0	0071.9	0097.5	0091.1	0016.7	0015.9
12:00:45	0	0	0984.9	0950.4	0281.7	0078.9	0077.0	0071.0	0097.5	0089.9	0016.4	0016.9
12:00:46	0	0	0985.4	0950.9	0281.8	0079.0	0077.0	0070.3	0097.5	0089.0	0016.2	0016.4
12:00:47	0	0	0985.7	0951.2	0281.8	0079.0	0077.1	0071.5	0097.5	0090.5	0016.6	0016.0
12:00:48	0	0	0985.4	0950.9	0281.8	0079.0	0077.0	0071.6	0097.5	0090.6	0016.6	0017.0
12:00:49	0	0	0985.4	0950.9	0281.8	0079.0	0077.0	0071.2	0097.5	0090.2	0016.5	0016.3
12:00:50	0	0	0985.2	0950.7	0281.9	0078.9	0077.0	0072.4	0097.5	0091.7	0016.9	0016.0
12:00:51	0	0	0985.2	0950.7	0281.9	0078.9	0077.0	0071.3	0097.5	0090.3	0016.5	0015.7
12:00:52	0	0	0985.4	0950.9	0281.9	0079.0	0077.0	0070.9	0097.5	0089.7	0016.4	0016.0
12:00:53	0	0	0985.7	0951.2	0281.9	0079.0	0077.1	0070.4	0097.5	0089.1	0016.2	0016.0
12:00:54	0	0	0986.0	0951.4	0282.0	0079.0	0077.1	0070.4	0097.5	0089.0	0016.2	0016.1

\*Values incorrect, see note on previous page

Table B-1. (Cont'd)

PRINT: 01R

FACC SMALL COMMUNITY SOLAR EXPERIMENT  
DATE: 03/03/82

PAGE: 0001

TIME	RLS	WLS	ET5 PERCENT	EM5 PERCENT	PT6 KW	PM6 KW	E6 KWH	ET6 PERCENT	EM6 PERCENT	DEP PERCENT	DEE PERCENT
12:00:00	0	0	0023.0	0022.9	0013.6	0013.5	0036.8	0083.5	0083.1	0015.4	0013.1
12:00:01	0	0	0023.2	0022.5	0013.6	0013.5	0036.8	0083.6	0083.0	0015.4	0013.1
12:00:02	0	0	0023.0	0023.1	0013.8	0013.6	0036.8	0083.8	0082.5	0015.5	0013.1
12:00:03	0	0	0023.0	0022.7	0013.4	0013.6	0036.8	0083.3	0084.0	0015.5	0013.1
12:00:04	0	0	0023.0	0022.7	0013.4	0013.5	0036.8	0083.3	0083.8	0015.4	0013.1
12:00:05	0	0	0023.1	0022.3	0013.3	0013.4	0036.8	0083.2	0083.9	0015.4	0013.1
12:00:06	0	0	0023.0	0022.7	0013.5	0013.5	0036.8	0083.4	0083.8	0015.4	0013.1
12:00:07	0	0	0023.0	0022.8	0013.5	0013.5	0036.8	0083.5	0083.1	0015.4	0013.1
12:00:08	0	0	0023.0	0022.7	0013.5	0013.5	0036.8	0083.4	0083.4	0015.4	0013.1
12:00:09	0	0	0023.0	0022.9	0013.6	0013.8	0036.8	0083.6	0084.5	0015.7	0013.1
12:00:10	0	0	0023.1	0022.5	0013.5	0013.4	0036.8	0083.4	0083.2	0015.3	0013.1
12:00:11	0	0	0023.0	0022.7	0013.5	0013.5	0036.8	0083.4	0083.6	0015.4	0013.1
12:00:12	0	0	0023.2	0022.5	0013.6	0013.5	0036.8	0083.6	0083.0	0015.4	0013.1
12:00:13	0	0	0023.1	0022.7	0013.5	0013.5	0036.8	0083.4	0083.7	0015.4	0013.1
12:00:14	0	0	0023.0	0022.7	0013.4	0013.4	0036.8	0083.3	0083.4	0015.3	0013.1
12:00:15	0	0	0023.0	0022.5	0013.3	0013.4	0036.8	0083.1	0084.1	0015.4	0013.1
12:00:16	0	0	0023.0	0022.8	0013.5	0013.6	0036.8	0083.4	0083.9	0015.5	0013.1
12:00:17	0	0	0023.1	0022.5	0013.4	0013.4	0036.8	0083.3	0083.3	0015.4	0013.1
12:00:18	0	0	0023.0	0022.4	0013.3	0013.3	0036.8	0083.1	0083.6	0015.2	0013.1
12:00:19	0	0	0023.0	0022.5	0013.3	0013.4	0036.8	0083.2	0083.9	0015.4	0013.1
12:00:20	0	0	0022.9	0023.5	0013.7	0013.7	0036.8	0083.8	0083.7	0015.7	0013.1
12:00:21	0	0	0023.1	0022.4	0013.4	0013.5	0036.8	0083.3	0083.7	0015.4	0013.1
12:00:22	0	0	0023.0	0023.1	0013.8	0013.7	0036.8	0083.8	0083.6	0015.7	0013.1
12:00:23	0	0	0023.1	0022.7	0013.6	0013.4	0036.8	0083.6	0082.6	0015.4	0013.1
12:00:24	0	0	0023.0	0022.8	0013.4	0013.4	0036.8	0083.3	0083.2	0015.3	0013.1
12:00:25	0	0	0023.1	0022.4	0013.4	0013.5	0036.8	0083.3	0083.6	0015.4	0013.1
12:00:26	0	0	0023.0	0022.8	0013.6	0013.5	0036.8	0083.6	0083.1	0015.4	0013.1
12:00:27	0	0	0023.0	0023.2	0013.6	0013.6	0036.9	0083.6	0083.1	0015.5	0013.1
12:00:28	0	0	0023.1	0022.7	0013.5	0013.5	0036.9	0083.5	0083.2	0015.4	0013.1
12:00:29	0	0	0023.0	0023.0	0013.7	0013.5	0036.9	0083.7	0082.4	0015.4	0013.1
12:00:30	0	0	0023.0	0022.9	0013.5	0013.4	0036.9	0083.4	0083.1	0015.3	0013.1
12:00:31	0	0	0023.0	0022.8	0013.5	0013.4	0036.9	0083.5	0082.7	0015.3	0013.1
12:00:32	0	0	0023.1	0022.5	0013.4	0013.6	0036.9	0083.3	0084.3	0015.5	0013.1
12:00:33	0	0	0023.0	0022.8	0013.5	0013.6	0036.9	0083.4	0084.2	0015.5	0013.1
12:00:34	0	0	0023.0	0022.9	0013.6	0013.4	0036.9	0083.5	0082.8	0015.3	0013.1
12:00:35	0	0	0023.0	0023.0	0013.7	0013.7	0036.9	0083.7	0083.4	0015.6	0013.1
12:00:36	0	0	0023.2	0022.1	0013.3	0013.5	0036.9	0083.1	0084.3	0015.4	0013.1
12:00:37	0	0	0023.1	0022.5	0013.5	0013.5	0036.9	0083.4	0083.5	0015.4	0013.1
12:00:38	0	0	0023.1	0023.1	0013.8	0013.6	0036.9	0083.8	0082.6	0015.5	0013.1
12:00:39	0	0	0023.0	0023.6	0014.2	0013.9	0036.9	0084.3	0082.5	0015.8	0013.1
12:00:40	0	0	0023.2	0022.2	0013.4	0013.5	0036.9	0083.3	0084.1	0015.4	0013.1
12:00:41	0	0	0023.2	0022.4	0013.6	0013.7	0036.9	0083.5	0084.1	0015.6	0013.1
12:00:42	0	0	0023.1	0023.5	0014.1	0014.0	0036.9	0084.2	0083.5	0015.9	0013.1
12:00:43	0	0	0023.1	0022.7	0013.5	0013.5	0036.9	0083.5	0083.4	0015.4	0013.1
12:00:44	0	0	0023.1	0022.1	0013.2	0013.2	0036.9	0083.0	0082.7	0015.0	0013.1
12:00:45	0	0	0023.0	0023.6	0014.1	0013.9	0036.9	0084.2	0082.8	0015.8	0013.1
12:00:46	0	0	0022.9	0023.4	0013.8	0013.6	0036.9	0083.8	0083.0	0015.5	0013.1
12:00:47	0	0	0023.1	0022.4	0013.4	0013.5	0036.9	0083.2	0084.0	0015.3	0013.1
12:00:48	0	0	0023.1	0023.8	0014.4	0014.3	0036.9	0084.6	0083.7	0016.3	0013.1
12:00:49	0	0	0023.0	0022.8	0013.6	0013.4	0036.9	0083.5	0082.4	0015.3	0013.1
12:00:50	0	0	0023.2	0022.2	0013.4	0013.4	0036.9	0083.2	0083.8	0015.3	0013.1
12:00:51	0	0	0023.0	0022.1	0013.0	0013.3	0036.9	0082.7	0084.3	0015.1	0013.1
12:00:52	0	0	0023.0	0022.7	0013.4	0013.5	0036.9	0083.2	0084.0	0015.4	0013.1
12:00:53	0	0	0022.9	0022.8	0013.4	0013.4	0037.0	0083.2	0083.8	0015.3	0013.1

PRINT 02 DESCRIPTION - PCA TEMPERATURES AND PRESSURES

<u>Print No.</u>	<u>Parameter</u>	<u>Description</u>
02L	RCSTP1	Receiver shell temperature at location 1*
02L	RCSTP2	Receiver shell temperature at location 2*
02L	RCSTP3	Receiver shell temperature at location 3*
02L	RCSTP4	Receiver shell temperature at location 4*
02L	RCSTP5	Receiver shell temperature at location 5*
02L	RCSTP6	Receiver shell temperature at location 6*
02L	RCOTTP	Receiver fluid outlet temperature
02L	TRINTP	Turbine inlet temperature
02L	TREXTP	Turbine exit temperature
02L	CNINTP	Condenser inlet temperature
-----		
02R	CNEXTP	Condenser exit temperature
02R	RLINTP	Regenerator liquid inlet temperature
02R	RLEXTP	Regenerator liquid exit temperature
02R	ALTTP**	Alternator temperature
02R	RCOTPR	Receiver outlet pressure
02R	TRINPR	Turbine inlet pressure
02R	TREXPR	Turbine exit pressure
02R	CNEXPR	Condenser exit pressure
02R	SYINPR	System (feed) pump inlet pressure
02R	SYOTPR	System (feed) pump exit pressure

\*Locations of these thermocouples are defined in Figure 4-2.

\*\*This thermocouple was inoperative for these tests.

Table B-2. Printout of 02 for Run 13

PRINT: 02L

FACC SMALL COMMUNITY SOLAR EXPERIMENT  
DATE: 03/03/82

PAGE: 0001

TIME	RLS	WLS	RCSTP1 DEG F	RCSTP2 DEG F	RCSTP3 DEG F	RCSTP4 DEG F	RCSTP5 DEG F	RCSTP6 DEG F	RCOTTP DEG F	TRINTP DEG F	TREXTP DEG F	CNINTP DEG F
12:00:00	0	0	0789.0	0775.4	0679.8	0606.2	0589.0	0394.2	0750.4	0745.2	0517.6	0172.9
12:00:01	0	0	0788.6	0778.2	0679.8	0606.6	0589.0	0394.2	0750.0	0741.6	0517.6	0172.6
12:00:02	0	0	0789.0	0776.2	0679.8	0607.0	0589.0	0394.2	0750.4	0741.6	0517.6	0173.0
12:00:03	0	0	0789.0	0777.8	0679.8	0607.8	0589.0	0394.2	0750.4	0743.6	0517.6	0173.0
12:00:04	0	0	0788.6	0775.4	0679.8	0606.2	0589.0	0393.8	0750.4	0744.0	0517.6	0173.0
12:00:05	0	0	0788.6	0776.2	0679.8	0605.4	0589.0	0394.2	0750.4	0741.6	0517.6	0173.0
12:00:06	0	0	0789.4	0776.2	0679.4	0607.0	0589.4	0394.2	0750.4	0743.6	0517.6	0173.2
12:00:07	0	0	0789.0	0776.2	0679.8	0607.0	0589.0	0394.2	0749.6	0743.6	0517.6	0173.2
12:00:08	0	0	0788.6	0777.8	0679.8	0608.2	0589.0	0394.2	0750.8	0743.6	0517.6	0173.2
12:00:09	0	0	0789.0	0777.8	0679.8	0607.0	0589.0	0394.2	0749.6	0743.6	0518.0	0173.0
12:00:10	0	0	0788.6	0777.8	0679.8	0606.2	0589.0	0394.2	0750.4	0743.6	0518.0	0173.5
12:00:11	0	0	0788.6	0777.8	0679.8	0606.6	0588.2	0394.2	0748.0	0743.6	0517.6	0173.0
12:00:12	0	0	0789.0	0776.2	0679.8	0606.2	0589.0	0393.4	0750.0	0744.0	0518.0	0173.1
12:00:13	0	0	0788.6	0777.8	0679.0	0606.2	0589.0	0393.8	0750.4	0744.0	0518.0	0173.2
12:00:14	0	0	0789.0	0777.8	0679.8	0606.2	0589.0	0394.2	0750.4	0743.2	0517.6	0173.2
12:00:15	0	0	0789.8	0777.8	0679.8	0606.2	0589.0	0394.2	0750.4	0743.6	0517.6	0173.4
12:00:16	0	0	0788.6	0777.8	0679.8	0606.2	0589.0	0394.2	0750.4	0743.6	0517.2	0173.4
12:00:17	0	0	0788.6	0777.8	0679.8	0606.6	0589.0	0394.2	0750.4	0743.6	0517.6	0173.3
12:00:18	0	0	0789.0	0776.2	0679.8	0606.2	0589.0	0393.8	0750.4	0743.6	0518.0	0173.2
12:00:19	0	0	0789.0	0775.8	0679.8	0606.2	0589.0	0395.4	0750.4	0743.6	0517.6	0173.3
12:00:20	0	0	0789.4	0777.8	0679.8	0606.2	0589.8	0394.2	0750.8	0743.6	0517.6	0173.5
12:00:21	0	0	0789.4	0777.8	0680.2	0606.2	0589.0	0393.8	0750.4	0743.6	0519.6	0173.4
12:00:22	0	0	0788.2	0777.8	0679.8	0606.6	0589.0	0394.2	0750.4	0741.6	0518.0	0173.5
12:00:23	0	0	0788.6	0775.8	0679.8	0607.0	0589.0	0394.2	0750.0	0743.6	0517.6	0173.6
12:00:24	0	0	0789.0	0776.2	0679.4	0607.0	0589.0	0394.2	0749.6	0743.6	0518.0	0173.7
12:00:25	0	0	0788.6	0777.8	0679.8	0606.6	0589.0	0394.2	0750.4	0741.6	0518.0	0173.9
12:00:26	0	0	0789.0	0776.6	0679.0	0606.6	0589.0	0394.2	0750.4	0741.6	0518.4	0174.2
12:00:27	0	0	0789.0	0775.8	0679.4	0606.2	0589.0	0394.2	0750.4	0744.0	0517.6	0173.8
12:00:28	0	0	0788.6	0779.4	0679.8	0606.2	0589.0	0393.8	0750.0	0743.6	0518.0	0174.0
12:00:29	0	0	0789.0	0776.6	0679.4	0606.2	0589.0	0394.2	0749.6	0743.6	0517.6	0173.8
12:00:30	0	0	0787.8	0775.8	0679.4	0606.2	0589.0	0394.2	0750.0	0740.8	0518.0	0173.6
12:00:31	0	0	0789.0	0776.2	0677.4	0607.4	0588.2	0393.8	0750.4	0741.6	0518.0	0173.5
12:00:32	0	0	0788.6	0776.2	0679.4	0606.2	0589.4	0394.2	0750.0	0741.6	0518.0	0173.5
12:00:33	0	0	0789.0	0776.2	0679.8	0606.2	0589.0	0394.2	0750.4	0743.6	0518.0	0173.4
12:00:34	0	0	0789.0	0776.2	0679.8	0606.2	0589.0	0394.2	0750.0	0741.6	0518.4	0173.4
12:00:35	0	0	0788.6	0776.2	0678.2	0606.2	0589.0	0394.2	0750.0	0741.6	0518.0	0173.3
12:00:36	0	0	0789.4	0777.8	0678.6	0606.2	0589.0	0393.4	0749.6	0741.6	0518.0	0173.4
12:00:37	0	0	0788.6	0777.8	0679.4	0607.0	0589.0	0394.2	0749.6	0741.6	0516.8	0173.5
12:00:38	0	0	0788.6	0777.8	0679.0	0606.6	0589.0	0394.2	0750.4	0743.6	0518.0	0173.5
12:00:39	0	0	0789.0	0775.8	0679.4	0607.4	0589.0	0394.2	0750.0	0743.6	0517.6	0173.3
12:00:40	0	0	0787.0	0777.8	0679.8	0606.2	0589.0	0394.6	0749.6	0741.6	0518.0	0173.3
12:00:41	0	0	0788.6	0775.4	0679.4	0606.6	0589.0	0393.8	0750.0	0743.6	0518.0	0173.5
12:00:42	0	0	0788.6	0776.2	0679.4	0606.6	0589.0	0394.2	0749.6	0743.6	0518.0	0173.6
12:00:43	0	0	0787.8	0777.8	0679.4	0607.0	0592.2	0394.2	0750.0	0743.6	0518.0	0173.5
12:00:44	0	0	0787.0	0775.8	0680.2	0606.6	0589.0	0394.2	0749.6	0741.6	0518.4	0173.5
12:00:45	0	0	0789.0	0777.8	0678.6	0607.0	0589.0	0394.2	0750.0	0743.6	0518.0	0173.6
12:00:46	0	0	0788.2	0775.4	0679.4	0605.4	0589.4	0394.6	0749.6	0743.6	0518.0	0173.5
12:00:47	0	0	0788.6	0776.2	0679.4	0607.0	0589.0	0394.2	0749.6	0741.6	0517.6	0173.5
12:00:48	0	0	0788.2	0776.2	0679.4	0607.0	0589.0	0394.2	0749.6	0743.6	0517.6	0173.3
12:00:49	0	0	0788.6	0775.4	0679.4	0605.8	0589.0	0393.0	0749.6	0743.6	0518.0	0172.6
12:00:50	0	0	0788.6	0775.4	0679.4	0607.0	0589.0	0394.2	0749.6	0743.6	0517.6	0174.3
12:00:51	0	0	0787.8	0775.4	0679.8	0606.6	0589.0	0394.2	0751.6	0741.6	0518.0	0172.9
12:00:52	0	0	0787.0	0775.0	0679.4	0607.4	0589.0	0393.4	0749.2	0741.6	0518.0	0173.0
12:00:53	0	0	0787.0	0775.0	0679.4	0606.2	0589.0	0394.2	0749.6	0740.8	0518.0	0173.1

Table B-2. (Cont'd)

FACC SMALL COMMUNITY SOLAR EXPERIMENT

DATE: 03/03/82

PRINT: O2R

PAGE: 0001

TIME	RLS	WLS	CNEXTP DEG F	RLINTP DEG F	RLEXTF DEG F	ALTFP * DEG F	RCOTPR PSIA	TRINPR PSIA	TREXPR PSIA	CNEXPR PSIA	SYINPR PSIA	SYOTPR PSIA
12:00:00	0	0	0082.8	0091.6	0380.4	0056.6	0494.0	0410.8	0001.5	0001.1	0027.8	0527.6
12:00:01	0	0	0082.8	0091.7	0378.4	0056.6	0494.0	0416.0	0001.5	0001.1	0027.4	0528.4
12:00:02	0	0	0082.6	0091.7	0378.4	0056.5	0493.6	0410.0	0001.5	0001.1	0027.8	0528.0
12:00:03	0	0	0082.7	0091.7	0378.8	0056.5	0494.4	0410.4	0001.5	0001.1	0027.7	0528.0
12:00:04	0	0	0082.6	0091.7	0377.6	0056.5	0494.4	0409.6	0001.5	0001.1	0027.8	0527.2
12:00:05	0	0	0082.7	0091.7	0378.4	0056.5	0494.4	0413.2	0001.5	0001.1	0027.4	0528.8
12:00:06	0	0	0082.6	0091.4	0378.4	0056.6	0494.4	0410.8	0001.5	0001.1	0027.6	0528.8
12:00:07	0	0	0082.6	0091.7	0376.8	0056.4	0494.4	0410.8	0001.5	0001.1	0027.7	0528.8
12:00:08	0	0	0082.6	0091.5	0378.0	0056.6	0494.4	0410.8	0001.5	0001.1	0027.8	0528.4
12:00:09	0	0	0082.6	0091.5	0378.8	0056.4	0494.4	0411.2	0001.5	0001.1	0027.5	0528.4
12:00:10	0	0	0082.6	0091.5	0378.8	0056.2	0493.6	0414.4	0001.5	0001.1	0027.5	0529.2
12:00:11	0	0	0082.5	0091.4	0378.4	0056.5	0493.6	0412.8	0001.5	0001.1	0027.6	0528.0
12:00:12	0	0	0082.5	0091.4	0378.4	0056.7	0494.0	0417.6	0001.5	0001.1	0027.7	0528.8
12:00:13	0	0	0082.4	0091.0	0378.4	0056.6	0494.8	0411.6	0001.5	0001.1	0027.9	0528.4
12:00:14	0	0	0082.4	0091.4	0378.4	0056.4	0494.8	0410.8	0001.5	0001.1	0027.7	0528.0
12:00:15	0	0	0082.5	0091.5	0378.4	0056.6	0494.4	0410.4	0001.5	0001.1	0027.8	0528.0
12:00:16	0	0	0082.7	0091.3	0378.4	0056.2	0494.8	0409.6	0001.5	0001.1	0027.8	0528.0
12:00:17	0	0	0082.4	0091.4	0379.2	0056.7	0494.0	0414.0	0001.5	0001.1	0027.7	0527.6
12:00:18	0	0	0082.2	0091.3	0378.4	0056.6	0492.0	0410.4	0001.5	0001.1	0027.8	0528.4
12:00:19	0	0	0082.3	0091.3	0378.4	0056.6	0495.6	0410.8	0001.5	0001.1	0027.8	0527.6
12:00:20	0	0	0082.3	0091.2	0378.4	0056.7	0495.2	0402.8	0001.5	0001.1	0028.0	0527.6
12:00:21	0	0	0082.3	0091.3	0379.2	0056.6	0495.6	0415.6	0001.5	0001.1	0027.7	0528.4
12:00:22	0	0	0082.1	0091.2	0378.4	0056.7	0494.4	0410.4	0001.5	0001.1	0027.8	0527.6
12:00:23	0	0	0082.1	0091.1	0378.4	0056.7	0494.0	0414.4	0001.5	0001.1	0027.6	0529.2
12:00:24	0	0	0082.2	0091.1	0379.6	0056.6	0494.4	0410.8	0001.5	0001.1	0027.6	0528.4
12:00:25	0	0	0082.3	0091.0	0378.4	0056.6	0494.4	0415.6	0001.5	0001.1	0027.8	0528.4
12:00:26	0	0	0082.1	0091.0	0378.0	0056.7	0494.4	0410.8	0001.5	0001.1	0027.8	0528.4
12:00:27	0	0	0082.1	0091.0	0378.4	0056.6	0494.4	0406.0	0001.5	0001.1	0027.8	0527.2
12:00:28	0	0	0082.0	0091.0	0379.2	0056.6	0494.4	0412.4	0001.5	0001.1	0027.7	0528.4
12:00:29	0	0	0082.1	0091.0	0378.4	0056.8	0494.4	0410.8	0001.5	0001.1	0027.7	0528.0
12:00:30	0	0	0082.1	0091.1	0376.8	0056.6	0495.6	0406.0	0001.5	0001.1	0027.8	0527.2
12:00:31	0	0	0082.1	0090.9	0378.4	0056.6	0494.4	0410.8	0001.5	0001.1	0027.7	0528.0
12:00:32	0	0	0082.1	0091.1	0379.6	0057.5	0494.8	0412.8	0001.5	0001.1	0027.9	0528.8
12:00:33	0	0	0082.0	0090.9	0379.2	0056.6	0494.8	0409.2	0001.5	0001.1	0027.8	0528.4
12:00:34	0	0	0082.3	0090.9	0379.2	0056.6	0494.8	0410.8	0001.5	0001.1	0027.7	0528.4
12:00:35	0	0	0081.9	0090.8	0378.4	0056.6	0494.4	0410.8	0001.5	0001.1	0027.9	0528.8
12:00:36	0	0	0081.9	0090.9	0379.2	0056.9	0493.6	0418.8	0001.5	0001.1	0027.6	0528.8
12:00:37	0	0	0082.0	0090.7	0379.2	0056.6	0494.4	0415.6	0001.5	0001.1	0027.6	0529.2
12:00:38	0	0	0081.9	0090.9	0379.2	0056.6	0495.6	0412.4	0001.5	0001.1	0027.8	0527.6
12:00:39	0	0	0081.9	0090.8	0378.4	0056.6	0494.8	0410.8	0001.5	0001.1	0027.7	0528.8
12:00:40	0	0	0081.9	0090.7	0378.4	0056.7	0494.4	0418.0	0001.5	0001.1	0027.5	0528.8
12:00:41	0	0	0081.8	0090.8	0379.2	0056.8	0493.6	0419.6	0001.5	0001.1	0027.3	0528.8
12:00:42	0	0	0082.3	0090.6	0378.4	0056.6	0494.0	0412.4	0001.5	0001.1	0028.0	0527.6
12:00:43	0	0	0081.8	0090.7	0379.2	0056.7	0494.4	0412.4	0001.5	0001.1	0027.8	0527.6
12:00:44	0	0	0081.8	0090.6	0379.2	0056.7	0494.0	0415.6	0001.5	0001.1	0027.5	0527.6
12:00:45	0	0	0082.0	0090.9	0379.2	0056.8	0494.8	0410.8	0001.5	0001.1	0027.7	0529.2
12:00:46	0	0	0081.8	0090.6	0378.4	0056.6	0492.0	0406.8	0001.5	0001.1	0027.9	0527.6
12:00:47	0	0	0081.6	0090.7	0379.6	0056.7	0494.0	0413.6	0001.5	0001.1	0027.4	0527.6
12:00:48	0	0	0081.8	0090.6	0378.4	0056.7	0494.4	0413.2	0001.5	0001.1	0027.5	0528.4
12:00:49	0	0	0081.8	0090.5	0378.4	0056.7	0492.4	0411.2	0001.5	0001.1	0027.5	0528.4
12:00:50	0	0	0081.9	0090.5	0379.2	0056.7	0493.6	0418.8	0001.5	0001.1	0027.3	0528.0
12:00:51	0	0	0081.8	0090.5	0379.2	0056.7	0493.2	0410.8	0001.5	0001.1	0027.7	0529.2
12:00:52	0	0	0081.4	0090.2	0378.4	0056.6	0494.8	0409.6	0001.5	0001.1	0027.9	0527.6
12:00:53	0	0	0081.8	0090.5	0378.4	0056.7	0494.8	0406.0	0001.5	0001.1	0027.9	0528.0

\* Thermocouple inoperative

PRINT 03 DESCRIPTION - OTHER PCA MEASUREMENTS

<u>Print No.</u>	<u>Parameter</u>	<u>Description</u>
03L	RCOTPR*	Receiver outlet pressure
03L	RCOTTP*	Receiver fluid outlet temp.
03L	TRVLPC	Vapor valve position command
03L	TRVLP	Vapor valve position
03L	TDAC1	Test channel (= RCOTPR)
03L	TDAC2	Test channel (= TRVLP)
03L	RCSTP5*	Receiver shell temp., location 5
03L	TURPM	Turbine (alternator) speed
03L	REOTCR**	Rectifier output current
03L	RESLVL	Reservoir fluid level
-----		
03R	DELT	Shell temp. rise in 100 sec.
03R	TCURR	Current average shell temp.
03R	ADCAL	A/D calibration check signal
03R	REOTVT**	Rectifier output voltage
03R	SETP	Setpoint used in control of receiver outlet temp.
03R	PPMODS	RCIA/PCA modes***
03R	DSEVT1	RCIA discrete events No. 1***
03R	RCSTP3*	Receiver shell temp., location 3
03R	RTDRS1	Receiver shell temp. using RTD No. 1 (location 3, temp. No. 7)
03R	RTDRS2	Receiver shell temp. using RTD No. 2 (location 3, temp. No. 8)

\*Repeated from Print 02.

\*\* Unreliable sensor.

\*\*\*See TR-SCSE-027E (Ref. B-2) for a definition of these modes and events.

Table B-3. Printout of 03 for Run 13

FACC SMALL COMMUNITY SOLAR EXPERIMENT  
DATE: 03/03/82

PRINT: 03L

PAGE: 0001

TIME	RLS	WLS	RCOTPR PSIA	RCOTTP DEG F	TRVLPC PERCENT	TRVLP PERCENT	TDAC1	TDAC2	RCSTP5 DEG F	TURPM KRPM	REOTCR AMPS	RESLVL PERCENT
12:00:00	0	0	0494.0	0750.4	0048.3	0047.3	0494.0	0047.3	0589.0	0047.6	0029.8	0078.2
12:00:01	0	0	0494.0	0750.0	0048.2	0047.7	0494.0	0047.7	0589.0	0047.6	0029.8	0078.0
12:00:02	0	0	0493.6	0750.4	0048.1	0047.2	0493.6	0047.2	0589.0	0047.6	0029.6	0078.3
12:00:03	0	0	0494.4	0750.4	0048.3	0047.4	0494.4	0047.4	0589.0	0047.6	0030.0	0078.3
12:00:04	0	0	0494.4	0750.4	0048.3	0047.4	0494.4	0047.4	0589.0	0047.6	0029.9	0078.1
12:00:05	0	0	0494.4	0750.4	0048.3	0047.4	0494.4	0047.4	0589.0	0047.6	0030.0	0077.7
12:00:06	0	0	0494.4	0750.4	0048.3	0047.4	0494.4	0047.4	0589.4	0047.6	0029.8	0078.1
12:00:07	0	0	0494.4	0749.6	0048.1	0047.2	0494.4	0047.2	0589.0	0047.6	0029.7	0078.3
12:00:08	0	0	0494.4	0750.8	0048.1	0047.3	0494.4	0047.3	0589.0	0047.6	0029.3	0077.8
12:00:09	0	0	0494.4	0749.6	0048.0	0047.3	0494.4	0047.3	0589.0	0047.6	0029.0	0077.0
12:00:10	0	0	0493.6	0750.4	0048.4	0047.6	0493.6	0047.6	0589.0	0047.6	0029.5	0077.4
12:00:11	0	0	0493.6	0748.0	0047.8	0047.4	0493.6	0047.4	0588.2	0047.6	0030.2	0077.7
12:00:12	0	0	0494.0	0750.0	0048.3	0047.7	0494.0	0047.7	0589.0	0047.8	0028.9	0077.7
12:00:13	0	0	0494.8	0750.4	0048.2	0047.4	0494.8	0047.4	0589.0	0047.6	0029.8	0077.4
12:00:14	0	0	0494.8	0750.4	0048.4	0047.4	0494.8	0047.4	0589.0	0047.6	0028.6	0076.7
12:00:15	0	0	0494.4	0750.4	0048.2	0047.4	0494.4	0047.4	0589.0	0047.6	0029.6	0077.4
12:00:16	0	0	0494.8	0750.4	0048.3	0047.3	0494.8	0047.3	0589.0	0047.6	0030.0	0077.7
12:00:17	0	0	0494.0	0750.4	0048.4	0047.6	0494.0	0047.6	0589.0	0047.6	0029.4	0077.0
12:00:18	0	0	0492.0	0750.4	0048.2	0047.4	0492.0	0047.4	0589.0	0047.8	0029.4	0077.0
12:00:19	0	0	0495.6	0750.4	0048.1	0047.4	0495.6	0047.4	0589.0	0047.6	0029.0	0077.5
12:00:20	0	0	0495.2	0750.8	0048.3	0046.6	0495.2	0046.6	0589.8	0047.4	0029.3	0077.8
12:00:21	0	0	0495.6	0750.4	0048.5	0047.6	0495.6	0047.6	0589.0	0047.8	0029.4	0077.1
12:00:22	0	0	0494.4	0750.4	0048.2	0047.4	0494.4	0047.4	0589.0	0047.6	0029.8	0078.0
12:00:23	0	0	0494.0	0750.0	0048.4	0047.6	0494.0	0047.6	0589.0	0047.6	0029.0	0078.8
12:00:24	0	0	0494.4	0749.6	0048.0	0047.3	0494.4	0047.3	0589.0	0047.6	0030.0	0077.3
12:00:25	0	0	0494.4	0750.4	0048.1	0047.6	0494.4	0047.6	0589.0	0047.6	0029.4	0077.1
12:00:26	0	0	0494.4	0750.4	0048.1	0047.4	0494.4	0047.4	0589.0	0047.6	0029.5	0077.5
12:00:27	0	0	0494.4	0750.4	0048.5	0047.1	0494.4	0047.1	0589.0	0047.6	0029.7	0077.2
12:00:28	0	0	0494.4	0750.0	0048.3	0047.4	0494.4	0047.4	0589.0	0047.8	0029.8	0077.2
12:00:29	0	0	0494.4	0749.6	0048.0	0047.3	0494.4	0047.3	0589.0	0047.6	0029.3	0077.3
12:00:30	0	0	0495.6	0750.0	0048.1	0047.0	0495.6	0047.0	0589.0	0047.6	0029.2	0077.1
12:00:31	0	0	0494.4	0750.4	0048.1	0047.4	0494.4	0047.4	0588.2	0047.6	0029.6	0077.3
12:00:32	0	0	0494.8	0750.0	0048.3	0047.6	0494.8	0047.6	0589.4	0047.6	0029.6	0077.4
12:00:33	0	0	0494.8	0750.4	0048.0	0047.2	0494.8	0047.2	0589.0	0047.6	0029.2	0077.0
12:00:34	0	0	0494.8	0750.0	0048.0	0047.4	0494.8	0047.4	0589.0	0047.6	0029.3	0076.9
12:00:35	0	0	0494.4	0750.0	0048.1	0047.4	0494.4	0047.4	0589.0	0047.6	0028.5	0077.0
12:00:36	0	0	0493.6	0749.6	0048.2	0048.0	0493.6	0048.0	0589.0	0047.8	0029.4	0077.8
12:00:37	0	0	0494.4	0749.6	0048.1	0047.4	0494.4	0047.4	0589.0	0047.6	0030.0	0077.7
12:00:38	0	0	0495.6	0750.4	0048.0	0047.4	0495.6	0047.4	0589.0	0047.6	0029.5	0077.0
12:00:39	0	0	0494.8	0750.0	0048.1	0047.4	0494.8	0047.4	0589.0	0047.6	0029.1	0077.1
12:00:40	0	0	0494.4	0749.6	0048.1	0047.7	0494.4	0047.7	0589.0	0047.8	0029.7	0077.2
12:00:41	0	0	0493.6	0750.0	0048.3	0047.8	0493.6	0047.8	0589.0	0047.8	0030.1	0077.0
12:00:42	0	0	0494.0	0749.6	0048.4	0047.4	0494.0	0047.4	0589.0	0047.6	0029.3	0077.4
12:00:43	0	0	0494.4	0750.0	0049.1	0047.6	0494.4	0047.6	0592.2	0047.6	0029.4	0077.7
12:00:44	0	0	0494.0	0749.6	0048.1	0047.4	0494.0	0047.4	0589.0	0047.6	0030.0	0076.7
12:00:45	0	0	0494.8	0750.0	0047.9	0047.4	0494.8	0047.4	0589.0	0047.6	0030.1	0077.0
12:00:46	0	0	0492.0	0749.6	0048.4	0047.0	0492.0	0047.0	0589.4	0047.6	0028.6	0077.5
12:00:47	0	0	0494.0	0749.6	0048.2	0047.4	0494.0	0047.4	0589.0	0047.6	0030.2	0076.9
12:00:48	0	0	0494.4	0749.6	0048.0	0047.4	0494.4	0047.4	0589.0	0047.8	0029.0	0076.9
12:00:49	0	0	0492.4	0749.6	0049.2	0047.3	0492.4	0047.3	0589.0	0047.6	0029.7	0076.6
12:00:50	0	0	0493.6	0749.6	0048.1	0047.7	0493.6	0047.7	0589.0	0047.6	0030.6	0077.1
12:00:51	0	0	0493.2	0751.6	0048.2	0047.4	0493.2	0047.4	0589.0	0047.6	0029.6	0077.2
12:00:52	0	0	0494.8	0749.2	0047.8	0047.2	0494.8	0047.2	0589.0	0047.6	0029.2	0077.0
12:00:53	0	0	0494.8	0749.6	0048.0	0047.0	0494.8	0047.0	0589.0	0047.6	0028.9	0077.1



Table B-3. (Cont'd)

PRINT: Q3R

FACC SMALL COMMUNITY SOLAR EXPERIMENT  
DATE: 03/03/82

PAGE: 0001

TIME	RLS	WLS	DELT DEQS	TCURR DEQ F	ADCAL	REDTV VOLTS	SETP DEQS	RPMODS EVENTS	DSEVT1 EVENTS	RCSTP3 DEQ F	RTDRS1 DEQ F	RTDRS2 DEQ F
12:00:00	0	0	-0008.2	0610.0	0155.6	0468.8	0590.3	00000010	00000110	0679.8	0692.0	0692.8
12:00:01	0	0	-0009.2	0608.9	0155.6	0452.8	0590.3	00000010	00000110	0679.8	0692.0	0691.6
12:00:02	0	0	-0010.0	0609.5	0155.6	0480.4	0590.3	00000010	00000110	0679.8	0692.4	0692.4
12:00:03	0	0	-0010.6	0609.2	0155.6	0483.6	0590.3	00000010	00000110	0679.8	0692.0	0690.4
12:00:04	0	0	-0011.2	0609.7	0155.6	0464.4	0590.3	00000010	00000110	0679.8	0691.6	0691.2
12:00:05	0	0	-0012.0	0609.1	0155.5	0464.0	0590.3	00000010	00000110	0679.8	0692.0	0691.6
12:00:06	0	0	-0012.6	0608.9	0155.8	0474.0	0590.3	00000010	00000110	0679.4	0692.0	0692.0
12:00:07	0	0	-0013.0	0609.1	0155.7	0466.4	0590.3	00000010	00000110	0679.8	0692.0	0692.0
12:00:08	0	0	-0013.0	0609.0	0155.6	0480.0	0590.3	00000010	00000110	0679.8	0692.0	0692.0
12:00:09	0	0	-0012.6	0609.7	0155.7	0463.6	0590.3	00000010	00000110	0679.8	0692.0	0691.6
12:00:10	0	0	-0012.4	0609.5	0155.6	0488.0	0590.3	00000010	00000110	0679.8	0692.0	0691.6
12:00:11	0	0	-0012.4	0609.3	0155.6	0468.0	0590.3	00000010	00000110	0679.8	0692.0	0691.6
12:00:12	0	0	-0012.6	0609.4	0155.1	0466.4	0590.3	00000010	00000110	0679.8	0691.6	0692.0
12:00:13	0	0	-0013.0	0608.9	0155.6	0470.0	0590.3	00000010	00000110	0679.0	0691.6	0691.6
12:00:14	0	0	-0013.0	0609.1	0155.6	0474.0	0590.3	00000010	00000110	0679.8	0692.0	0692.0
12:00:15	0	0	-0012.8	0609.4	0155.6	0468.4	0590.3	00000010	00000110	0679.8	0693.2	0692.0
12:00:16	0	0	-0012.4	0609.3	0155.6	0462.0	0590.3	00000010	00000110	0679.8	0692.0	0690.4
12:00:17	0	0	-0012.0	0609.4	0155.6	0476.4	0590.3	00000010	00000110	0679.8	0692.0	0691.6
12:00:18	0	0	-0012.0	0609.4	0155.6	0460.0	0590.3	00000010	00000110	0679.8	0692.0	0691.6
12:00:19	0	0	-0012.0	0608.9	0155.6	0471.6	0590.3	00000010	00000110	0679.8	0691.6	0691.6
12:00:20	0	0	-0011.8	0609.2	0155.6	0469.6	0590.3	00000010	00000110	0679.8	0691.6	0691.6
12:00:21	0	0	-0011.4	0609.2	0155.6	0462.8	0590.3	00000010	00000110	0680.2	0691.6	0691.6
12:00:22	0	0	-0010.8	0609.3	0155.6	0476.0	0590.3	00000010	00000110	0679.8	0691.6	0691.6
12:00:23	0	0	-0010.4	0609.4	0155.6	0480.0	0590.3	00000010	00000110	0679.8	0692.4	0691.2
12:00:24	0	0	-0010.2	0609.1	0155.6	0470.4	0590.3	00000010	00000110	0679.4	0691.6	0694.0
12:00:25	0	0	-0009.8	0609.1	0155.6	0475.2	0590.3	00000010	00000110	0679.8	0691.2	0690.4
12:00:26	0	0	-0009.6	0609.4	0155.6	0475.2	0590.3	00000010	00000110	0679.0	0691.6	0691.6
12:00:27	0	0	-0009.8	0609.0	0155.6	0474.0	0590.3	00000010	00000110	0679.4	0691.6	0691.6
12:00:28	0	0	-0009.8	0608.9	0155.8	0471.6	0590.3	00000010	00000110	0679.8	0691.6	0692.0
12:00:29	0	0	-0009.8	0609.6	0155.6	0478.4	0590.3	00000010	00000110	0679.4	0691.6	0691.6
12:00:30	0	0	-0010.2	0609.1	0155.1	0461.2	0590.3	00000010	00000110	0679.4	0691.2	0691.6
12:00:31	0	0	-0010.6	0608.9	0155.6	0476.0	0590.3	00000010	00000110	0677.4	0691.6	0691.6
12:00:32	0	0	-0010.8	0608.7	0155.6	0466.0	0590.3	00000010	00000110	0679.4	0691.6	0690.8
12:00:33	0	0	-0010.8	0608.9	0155.6	0489.2	0590.3	00000010	00000110	0679.8	0691.2	0691.6
12:00:34	0	0	-0010.8	0609.0	0155.6	0485.6	0590.3	00000010	00000110	0679.8	0691.6	0691.6
12:00:35	0	0	-0011.0	0609.0	0155.6	0462.4	0590.3	00000010	00000110	0678.2	0691.2	0691.2
12:00:36	0	0	-0011.2	0608.7	0155.6	0466.4	0590.3	00000010	00000110	0678.6	0691.2	0691.6
12:00:37	0	0	-0011.2	0609.0	0155.6	0460.4	0590.3	00000010	00000110	0679.4	0691.2	0690.8
12:00:38	0	0	-0011.2	0609.4	0155.1	0470.0	0590.3	00000010	00000110	0679.0	0691.6	0691.6
12:00:39	0	0	-0011.4	0609.3	0155.6	0463.6	0590.3	00000010	00000110	0679.4	0691.6	0691.6
12:00:40	0	0	-0011.4	0609.1	0155.6	0455.6	0590.3	00000010	00000110	0679.8	0691.2	0690.4
12:00:41	0	0	-0011.4	0609.4	0155.6	0466.0	0590.3	00000010	00000110	0679.4	0691.2	0690.8
12:00:42	0	0	-0011.4	0608.8	0155.6	0477.2	0590.3	00000010	00000110	0679.4	0691.2	0691.6
12:00:43	0	0	-0011.0	0609.1	0155.6	0461.2	0590.3	00000010	00000110	0679.4	0691.2	0690.8
12:00:44	0	0	-0010.6	0609.3	0155.6	0455.2	0590.3	00000010	00000110	0680.2	0691.6	0690.8
12:00:45	0	0	-0010.2	0609.1	0155.6	0462.4	0590.3	00000010	00000110	0678.6	0691.2	0691.6
12:00:46	0	0	-0009.8	0609.3	0155.6	0466.4	0590.3	00000010	00000110	0679.4	0691.2	0690.4
12:00:47	0	0	-0009.6	0608.7	0155.6	0466.4	0590.3	00000010	00000110	0679.4	0692.4	0691.6
12:00:48	0	0	-0009.4	0609.1	0155.6	0468.8	0590.3	00000010	00000110	0679.4	0691.2	0690.0
12:00:49	0	0	-0009.4	0609.1	0155.6	0472.0	0590.3	00000010	00000110	0679.4	0691.2	0691.2
12:00:50	0	0	-0009.6	0608.9	0155.6	0456.8	0590.3	00000010	00000110	0679.4	0691.6	0690.8
12:00:51	0	0	-0009.8	0608.9	0155.1	0476.8	0590.3	00000010	00000110	0679.8	0691.2	0690.4
12:00:52	0	0	-0010.0	0608.9	0155.6	0464.8	0590.3	00000010	00000110	0679.4	0690.4	0690.8
12:00:53	0	0	-0010.0	0609.2	0155.6	0466.4	0590.3	00000010	00000110	0679.4	0690.4	0690.4

PRINT 04 DESCRIPTION - PCS EVENTS (DISCRETES)

<u>Print No.</u>	<u>Parameter*</u>	<u>Description</u>
04L	PPMODS**	RCIA/PCA modes
04L	FLTDAT	PCA fault summary
04L	DSCMD1	RCIA discrete commands No. 1
04L	DSCMD2	RCIA discrete commands No. 2
04L	DSEVT1**	RCIA discrete events No. 1
04L	DSEVT2	RCIA discrete events No. 2
04L	PCAF11	PCA faults No. 1
04L	PCAF12	PCA faults No. 1
04L	RCFLTS	RCIA faults
04L	CHNERR	Analog error channel No.
-----		
04R	RCIACD	RCIA discrete commands No. 1
04R	RCIAC2	RCIA discrete commands No. 2
04R	ETSEV1	ETS discrete events No. 1
04R	ETSEV2	ETS discrete events No. 2 (not used)

\*These parameters are defined in TR-SCSE-027E (Ref. B-2) or Ref. B-3.

\*\*Repeated from Print 03R.



Table B-4. (Cont'd)

PRINT: 04R

FACC SMALL COMMUNITY SOLAR EXPERIMENT  
DATE: 03/03/82

PAGE: 0001

TIME	RLS	WLS	RCIACD EVENTS	RCIAC2 EVENTS	ETSEV1 EVENTS	ETSEV2 EVENTS
12:00:00	0	0	01000000	00000000	/0110111	
12:00:01	0	0	01000000	00000000	/0110111	
12:00:02	0	0	01000000	00000000	/0110111	
12:00:03	0	0	01000000	00000000	/0110111	
12:00:04	0	0	01000000	00000000	/0110111	
12:00:05	0	0	01000000	00000000	/0110111	
12:00:06	0	0	01000000	00000000	/0110111	
12:00:07	0	0	01000000	00000000	/0110111	
12:00:08	0	0	01000000	00000000	/0110111	
12:00:09	0	0	01000000	00000000	/0110111	
12:00:10	0	0	01000000	00000000	/0110111	
12:00:11	0	0	01000000	00000000	/0110111	
12:00:12	0	0	01000000	00000000	/0110111	
12:00:13	0	0	01000000	00000000	/0110111	
12:00:14	0	0	01000000	00000000	/0110111	
12:00:15	0	0	01000000	00000000	/0110111	
12:00:16	0	0	01000000	00000000	/0110111	
12:00:17	0	0	01000000	00000000	/0110111	
12:00:18	0	0	01000000	00000000	/0110111	
12:00:19	0	0	01000000	00000000	/0110111	
12:00:20	0	0	01000000	00000000	/0110111	
12:00:21	0	0	01000000	00000000	/0110111	
12:00:22	0	0	01000000	00000000	/0110111	
12:00:23	0	0	01000000	00000000	/0110111	
12:00:24	0	0	01000000	00000000	/0110111	
12:00:25	0	0	01000000	00000000	/0110111	
12:00:26	0	0	01000000	00000000	/0110111	
12:00:27	0	0	01000000	00000000	/0110111	
12:00:28	0	0	01000000	00000000	/0110111	
12:00:29	0	0	01000000	00000000	/0110111	
12:00:30	0	0	01000000	00000000	/0110111	
12:00:31	0	0	01000000	00000000	/0110111	
12:00:32	0	0	01000000	00000000	/0110111	
12:00:33	0	0	01000000	00000000	/0110111	
12:00:34	0	0	01000000	00000000	/0110111	
12:00:35	0	0	01000000	00000000	/0110111	
12:00:36	0	0	01000000	00000000	/0110111	
12:00:37	0	0	01000000	00000000	/0110111	
12:00:38	0	0	01000000	00000000	/0110111	
12:00:39	0	0	01000000	00000000	/0110111	
12:00:40	0	0	01000000	00000000	/0110111	
12:00:41	0	0	01000000	00000000	/0110111	
12:00:42	0	0	01000000	00000000	/0110111	
12:00:43	0	0	01000000	00000000	/0110111	
12:00:44	0	0	01000000	00000000	/0110111	
12:00:45	0	0	01000000	00000000	/0110111	
12:00:46	0	0	01000000	00000000	/0110111	
12:00:47	0	0	01000000	00000000	/0110111	
12:00:48	0	0	01000000	00000000	/0110111	
12:00:49	0	0	01000000	00000000	/0110111	
12:00:50	0	0	01000000	00000000	/0110111	
12:00:51	0	0	01000000	00000000	/0110111	
12:00:52	0	0	01000000	00000000	/0110111	
12:00:53	0	0	01000000	00000000	/0110111	

PRINT 05 DESCRIPTION - ETS DATA

<u>Print No.</u>	<u>Parameter</u>	<u>Description</u>
05L	INDCAM	Inverter input current (dc)
05L	INDCVL	Inverter input voltage (dc)
05L	INOTP1*	Inverter output voltage, Phase 1 (ac)
05L	INOTP2*	Inverter output voltage, Phase 2 (ac)
05L	INOTP3*	Inverter output voltage, Phase 3 (ac)
05L	INVA1	Inverter output current, Phase 1 (ac)
05L	INVA2	Inverter output current, Phase 2 (ac)
05L	INVA3	Inverter output current, Phase 3 (ac)
05L	INVPF1*	Inverter output power factor, Phase 1
05L	ETSEV1**	ETS discrete events No. 1
-----		
05R	PYRHL4***	Local Eppley pyrliometer reading
05R	AMBTMP	Ambient temperature (from weather station)
05R	ADCAL****	A/D calibration check signal
05R	ALTVL1	Alternator voltage Phase 1
05R	ALTVL2	Alternator voltage, Phase 2
05R	ALTVL3	Alternator voltage, Phase 3

\*Valid only when inverter connected to the grid. Final sensor calibration completed after these tests were completed.

\*\*Repeated from Print 04R.

\*\*\*Repeated from Print 01L; same as PML.

\*\*\*\*Repeated from print 03R.

Table B-5. Printout of 05 for Run 13

PRINT: 05L

FACC SMALL COMMUNITY SOLAR EXPERIMENT

DATE: 03/03/82

PAGE: 0001

TIME	RLS	WLS	INDCAM AMPS	INDCVL VOLTS	INDTP1* VOLTS	INDTP2* VOLTS	INDTP3* VOLTS	INVA1 AMPS	INVA2 AMPS	INVA3 AMPS	INVPF1	ETSEV1 EVENTS
12:00:00	0	0	0032.2	0503.2	0001.0	0000.0	0004.2	0023.9	0024.7	0024.5	-0086.5	/0110111
12:00:01	0	0	0032.5	0500.1	0004.5	0000.0	0000.1	0024.7	0024.5	0024.0	-0088.4	/0110111
12:00:02	0	0	0032.5	0505.0	0001.7	0000.0	0000.0	0024.9	0024.4	0024.0	-0088.5	/0110111
12:00:03	0	0	0032.3	0498.6	0000.4	0000.4	0000.0	0024.0	0024.5	0024.8	-0088.4	/0110111
12:00:04	0	0	0031.9	0503.7	0002.4	0000.0	0000.1	0024.8	0023.6	0024.7	-0086.9	/0110111
12:00:05	0	0	0032.1	0498.4	0002.6	0000.0	0000.0	0024.4	0024.6	0024.0	-0086.4	/0110111
12:00:06	0	0	0032.3	0498.9	0000.0	0000.0	0001.3	0024.7	0023.6	0024.9	-0087.8	/0110111
12:00:07	0	0	0032.4	0499.8	0004.1	0000.0	0000.4	0024.9	0024.3	0023.9	-0088.4	/0110111
12:00:08	0	0	0032.4	0498.1	0000.7	0000.0	0001.6	0024.1	0024.7	0024.3	-0088.6	/0110111
12:00:09	0	0	0032.6	0499.1	0000.0	0000.0	0001.3	0024.7	0023.9	0025.3	-0087.7	/0110111
12:00:10	0	0	0032.2	0501.3	0002.1	0000.1	0000.0	0024.4	0024.6	0024.0	-0086.3	/0110111
12:00:11	0	0	0032.3	0499.6	0003.3	0000.0	0000.0	0024.3	0023.8	0025.1	-0087.1	/0110111
12:00:12	0	0	0032.4	0501.8	0000.0	0000.0	0000.1	0024.7	0023.6	0024.9	-0087.8	/0110111
12:00:13	0	0	0032.4	0497.9	0000.4	0000.0	0001.9	0024.1	0024.7	0024.4	-0088.5	/0110111
12:00:14	0	0	0032.0	0502.8	0000.4	0000.0	0003.6	0024.0	0024.2	0024.8	-0087.9	/0110111
12:00:15	0	0	0032.0	0498.6	0006.4	0003.2	0001.4	0024.9	0023.7	0024.4	-0086.3	/0110111
12:00:16	0	0	0032.5	0497.4	0001.4	0000.0	0000.4	0024.4	0023.8	0025.2	-0087.0	/0110111
12:00:17	0	0	0032.3	0498.6	0001.6	0000.0	0001.7	0024.3	0023.7	0025.0	-0087.2	/0110111
12:00:18	0	0	0032.0	0497.6	0002.0	0000.0	0000.1	0024.9	0023.9	0023.9	-0088.7	/0110111
12:00:19	0	0	0032.0	0499.8	0000.8	0000.4	0004.3	0024.2	0023.8	0025.0	-0087.5	/0110111
12:00:20	0	0	0032.5	0504.0	0002.7	0000.0	0000.0	0025.0	0023.8	0025.0	-0086.9	/0110111
12:00:21	0	0	0032.2	0499.3	0002.3	0000.0	0003.0	0023.9	0024.6	0024.6	-0086.3	/0110111
12:00:22	0	0	0032.8	0500.1	0001.0	0000.0	0001.4	0024.8	0023.8	0025.2	-0087.7	/0110111
12:00:23	0	0	0032.4	0501.8	0000.7	0000.0	0001.4	0025.0	0023.9	0024.1	-0088.6	/0110111
12:00:24	0	0	0032.2	0499.8	0000.4	0000.0	0001.7	0023.9	0024.7	0024.3	-0088.6	/0110111
12:00:25	0	0	0032.0	0503.0	0003.6	0005.5	0001.3	0024.5	0023.6	0025.0	-0087.1	/0110111
12:00:26	0	0	0032.3	0503.0	0000.8	0000.1	0000.5	0024.0	0024.8	0024.4	-0086.0	/0110111
12:00:27	0	0	0032.3	0504.2	0000.0	0000.1	0001.3	0024.0	0024.5	0024.8	-0086.4	/0110111
12:00:28	0	0	0032.3	0500.8	0000.1	0000.0	0001.0	0025.0	0024.1	0024.0	-0088.6	/0110111
12:00:29	0	0	0032.4	0504.0	0001.1	0000.0	0000.2	0024.4	0024.6	0024.1	-0088.5	/0110111
12:00:30	0	0	0032.0	0505.0	0001.4	0000.4	0000.0	0024.2	0023.8	0025.0	-0087.6	/0110111
12:00:31	0	0	0032.1	0504.0	0000.4	0001.4	0000.4	0024.0	0024.7	0024.2	-0086.0	/0110111
12:00:32	0	0	0032.2	0498.4	0002.9	0000.0	0000.0	0024.1	0024.8	0024.4	-0086.2	/0110111
12:00:33	0	0	0032.4	0497.4	0000.0	0000.0	0001.6	0024.6	0023.7	0025.1	-0087.7	/0110111
12:00:34	0	0	0032.4	0500.1	0000.0	0000.0	0002.1	0024.9	0024.2	0023.9	-0088.4	/0110111
12:00:35	0	0	0032.6	0502.0	0001.9	0000.1	0000.0	0024.1	0024.5	0025.0	-0088.3	/0110111
12:00:36	0	0	0032.1	0497.4	0003.0	0000.0	0001.0	0025.0	0024.2	0023.9	-0086.2	/0110111
12:00:37	0	0	0032.2	0500.3	0001.9	0000.0	0000.0	0023.9	0024.7	0024.5	-0086.4	/0110111
12:00:38	0	0	0032.6	0504.2	0000.7	0000.0	0000.0	0024.2	0024.1	0025.1	-0087.1	/0110111
12:00:39	0	0	0033.3	0503.7	0001.3	0000.0	0001.7	0025.4	0024.2	0024.5	-0088.6	/0110111
12:00:40	0	0	0032.2	0498.4	0002.7	0000.0	0000.5	0024.0	0024.3	0024.9	-0088.3	/0110111
12:00:41	0	0	0032.5	0499.3	0001.7	0000.2	0000.0	0025.2	0024.1	0024.3	-0086.0	/0110111
12:00:42	0	0	0033.2	0503.2	0000.0	0000.0	0001.9	0025.3	0024.8	0024.3	-0086.3	/0110111
12:00:43	0	0	0032.4	0499.6	0005.8	0000.0	0000.2	0024.3	0023.8	0025.1	-0087.1	/0110111
12:00:44	0	0	0031.7	0500.8	0002.4	0000.0	0000.4	0024.6	0023.4	0024.2	-0088.4	/0110111
12:00:45	0	0	0033.2	0503.2	0005.4	0000.1	0000.2	0024.6	0025.0	0024.5	-0088.5	/0110111
12:00:46	0	0	0032.5	0504.5	0003.3	0001.3	0000.0	0025.1	0024.3	0024.1	-0086.0	/0110111
12:00:47	0	0	0032.1	0498.9	0002.0	0000.0	0000.7	0025.0	0024.2	0023.9	-0086.4	/0110111
12:00:48	0	0	0033.9	0501.8	0002.1	0000.0	0001.0	0024.9	0024.5	0025.8	-0087.0	/0110111
12:00:49	0	0	0032.3	0502.8	0001.3	0000.2	0000.0	0025.0	0023.9	0024.0	-0088.6	/0110111
12:00:50	0	0	0032.2	0497.4	0000.4	0001.0	0000.0	0023.9	0024.6	0024.5	-0088.2	/0110111
12:00:51	0	0	0031.5	0498.4	0001.7	0001.7	0000.0	0024.3	0023.4	0024.8	-0086.9	/0110111
12:00:52	0	0	0032.2	0497.4	0002.1	0000.0	0001.6	0025.0	0024.1	0024.0	-0086.0	/0110111
12:00:53	0	0	0032.1	0498.9	0001.6	0000.0	0000.1	0024.5	0024.5	0024.0	-0086.3	/0110111

\*Not valid for these tests

Table B-5. (Cont'd)

PRINT: OSR

FACC SMALL COMMUNITY SOLAR EXPERIMENT

DATE: 03/03/82

PAGE: 0001

TIME	RLS	WLS	PYRHL4 W/M*H	AMBTMP DEG F	ADCAL	ALTVL1 VOLTS	ALTVL2 VOLTS	ALTVL3 VOLTS
12:00:00	0	0	0982.8	0054.5	0155.6	0236.4	0236.0	0238.0
12:00:01	0	0	0982.5	0054.5	0155.6	0237.4	0236.4	0238.6
12:00:02	0	0	0982.8	0054.5	0155.6	0237.4	0236.2	0238.4
12:00:03	0	0	0982.8	0054.5	0155.6	0237.2	0236.2	0238.6
12:00:04	0	0	0982.8	0054.5	0155.6	0237.2	0236.2	0238.2
12:00:05	0	0	0982.5	0054.5	0155.5	0237.4	0236.6	0238.4
12:00:06	0	0	0982.5	0054.5	0155.8	0237.4	0236.2	0238.2
12:00:07	0	0	0982.8	0054.5	0155.7	0237.4	0236.2	0238.4
12:00:08	0	0	0983.4	0054.5	0155.6	0237.8	0236.2	0238.4
12:00:09	0	0	0983.1	0054.5	0155.7	0237.4	0236.2	0238.2
12:00:10	0	0	0983.4	0054.5	0155.6	0237.2	0236.2	0238.6
12:00:11	0	0	0982.8	0054.5	0155.6	0237.4	0236.2	0238.4
12:00:12	0	0	0982.8	0054.5	0155.1	0237.6	0236.2	0238.4
12:00:13	0	0	0982.5	0054.5	0155.6	0237.2	0236.4	0238.4
12:00:14	0	0	0983.1	0054.5	0155.6	0237.4	0236.2	0238.2
12:00:15	0	0	0982.5	0054.5	0155.6	0237.2	0236.2	0238.4
12:00:16	0	0	0982.8	0054.5	0155.6	0237.0	0235.8	0238.2
12:00:17	0	0	0982.8	0054.5	0155.6	0237.8	0236.0	0238.4
12:00:18	0	0	0983.1	0054.5	0155.6	0237.4	0236.2	0238.0
12:00:19	0	0	0982.8	0054.5	0155.6	0237.4	0235.6	0238.0
12:00:20	0	0	0982.8	0054.5	0155.6	0236.8	0234.8	0238.0
12:00:21	0	0	0982.8	0054.5	0155.6	0237.4	0236.0	0238.0
12:00:22	0	0	0983.1	0054.5	0155.6	0237.4	0235.6	0238.0
12:00:23	0	0	0982.8	0054.5	0155.6	0237.4	0235.6	0238.4
12:00:24	0	0	0983.1	0054.5	0155.6	0237.2	0236.2	0239.0
12:00:25	0	0	0983.1	0054.5	0155.6	0236.8	0236.0	0238.2
12:00:26	0	0	0983.4	0054.5	0155.6	0237.2	0236.6	0238.2
12:00:27	0	0	0983.7	0054.5	0155.6	0237.4	0236.2	0238.2
12:00:28	0	0	0983.7	0054.5	0155.8	0237.4	0236.0	0238.4
12:00:29	0	0	0983.4	0054.5	0155.6	0237.4	0236.2	0238.2
12:00:30	0	0	0983.7	0054.5	0155.1	0237.2	0236.2	0238.2
12:00:31	0	0	0984.0	0054.5	0155.6	0237.6	0236.2	0238.4
12:00:32	0	0	0984.0	0054.5	0155.6	0237.4	0236.0	0238.4
12:00:33	0	0	0983.7	0054.5	0155.6	0237.4	0236.0	0238.2
12:00:34	0	0	0983.7	0054.5	0155.6	0237.2	0236.6	0238.2
12:00:35	0	0	0983.7	0054.5	0155.6	0237.4	0236.2	0238.4
12:00:36	0	0	0983.7	0054.5	0155.6	0237.4	0236.2	0238.4
12:00:37	0	0	0985.2	0054.5	0155.6	0237.2	0236.6	0238.4
12:00:38	0	0	0984.9	0054.5	0155.1	0236.8	0236.0	0238.4
12:00:39	0	0	0984.6	0054.5	0155.6	0236.4	0236.4	0239.0
12:00:40	0	0	0984.9	0054.5	0155.6	0237.4	0236.4	0238.4
12:00:41	0	0	0984.9	0054.5	0155.6	0237.8	0236.6	0238.8
12:00:42	0	0	0984.9	0054.5	0155.6	0237.2	0236.2	0238.2
12:00:43	0	0	0984.3	0054.5	0155.6	0237.2	0236.2	0238.2
12:00:44	0	0	0984.6	0054.5	0155.6	0236.4	0236.6	0238.4
12:00:45	0	0	0984.9	0054.5	0155.6	0237.4	0236.4	0238.2
12:00:46	0	0	0985.4	0054.5	0155.6	0236.8	0236.4	0237.8
12:00:47	0	0	0985.7	0054.5	0155.6	0237.4	0236.6	0238.6
12:00:48	0	0	0985.4	0054.5	0155.6	0237.4	0236.6	0238.4
12:00:49	0	0	0985.4	0054.5	0155.6	0237.4	0236.2	0238.4
12:00:50	0	0	0985.2	0054.5	0155.6	0237.6	0236.6	0238.8
12:00:51	0	0	0985.2	0055.0	0155.1	0237.4	0236.2	0238.2
12:00:52	0	0	0985.4	0055.0	0155.6	0237.4	0236.0	0238.4
12:00:53	0	0	0985.7	0055.0	0155.6	0237.0	0236.0	0238.2

PRINT 06 DESCRIPTION - WEATHER DATA

<u>Print No.</u>	<u>Parameter</u>	<u>Description</u>
06L	MVREF	Reference signal value
06L	AMBTP*	Ambient temperature
06L	WINDSP	Wind speed
06L	WINDIR	Wind direction (0° = North 270° = West)
06L	DEWPT	Dew point temperature
06L	PYRHL1	Pyrheliometer No. 1 (Kendall)
06L	PYRHL2	Pyrheliometer No. 2 (Kendall)
06L	PYRNOM	Pyranometer output
06L	BARPR	Barometric pressure
06L	PYRHL4***	Local Eppley pyrliometer reading
-----		
06R	PYRHL3	Pyrheliometer No. 3 (Eppley)
06R	QCALC****	Correlation for input power based on thermocouple readings; ((RCSTP1-RCSTP2) X factor)

\*Repeated from Print 5R.

\*\*Repeated from Print 01L and 05R.

\*\*\*Repeated from Print 01L; same as PM1.

\*\*\*\*Not Calibrated for TBC; results for these tests are invalid.



Table B-6. Printout of 06 for Run 13

PRINT: 06L

FACC SMALL COMMUNITY SOLAR EXPERIMENT  
DATE: 03/03/82

PAGE: 0001

TIME	RLS	WLS	MVREF PERCENT	AMBT DEG F	WINDSP MPH	WINDIR DEGS	DEWPT DEG F	PYRHL1 W/M*M	PYRHL2 W/M*M	PYRNOM W/M*M	BARPR IN OF HG	PYRHL4 W/M*M
12:00:00	0	0	0099.9	0054.5	0008.6	0228.4	0019.2	0995.0	1006.0	0853.0	0027.5	0982.8
12:00:01	0	0	0099.9	0054.5	0008.6	0228.4	0019.2	0995.0	1006.0	0853.0	0027.5	0982.5
12:00:02	0	0	0099.9	0054.5	0008.6	0228.4	0019.2	0995.0	1006.0	0853.0	0027.5	0982.8
12:00:03	0	0	0099.9	0054.5	0008.6	0228.4	0019.2	0995.0	1006.0	0853.0	0027.5	0982.8
12:00:04	0	0	0099.9	0054.5	0008.6	0228.4	0019.2	0995.0	1006.0	0853.0	0027.5	0982.8
12:00:05	0	0	0099.9	0054.5	0008.6	0228.4	0019.2	0995.0	1006.0	0853.0	0027.5	0982.5
12:00:06	0	0	0099.9	0054.5	0008.6	0228.4	0019.2	0995.0	1006.0	0853.0	0027.5	0982.5
12:00:07	0	0	0099.9	0054.5	0008.6	0228.4	0019.2	0995.0	1006.0	0853.0	0027.5	0982.8
12:00:08	0	0	0099.9	0054.5	0008.6	0228.4	0019.2	0995.0	1006.0	0853.0	0027.5	0983.4
12:00:09	0	0	0099.9	0054.5	0008.6	0228.4	0019.2	0995.0	1006.0	0853.0	0027.5	0983.1
12:00:10	0	0	0099.9	0054.5	0008.6	0228.4	0019.2	0995.0	1006.0	0853.0	0027.5	0983.4
12:00:11	0	0	0099.9	0054.5	0008.6	0228.4	0019.2	0995.0	1006.0	0853.0	0027.5	0982.8
12:00:12	0	0	0099.9	0054.5	0008.6	0228.4	0019.2	0995.0	1006.0	0853.0	0027.5	0982.8
12:00:13	0	0	0099.9	0054.5	0008.6	0228.4	0019.2	0995.0	1006.0	0853.0	0027.5	0982.5
12:00:14	0	0	0099.9	0054.5	0008.6	0228.4	0019.2	0995.0	1006.0	0853.0	0027.5	0983.1
12:00:15	0	0	0099.9	0054.5	0008.6	0228.4	0019.2	0995.0	1006.0	0853.0	0027.5	0982.5
12:00:16	0	0	0099.9	0054.5	0008.6	0228.4	0019.2	0995.0	1006.0	0853.0	0027.5	0982.8
12:00:17	0	0	0099.9	0054.5	0008.6	0228.4	0019.2	0995.0	1006.0	0853.0	0027.5	0982.8
12:00:18	0	0	0099.9	0054.5	0008.6	0228.4	0019.2	0995.0	1006.0	0853.0	0027.5	0983.1
12:00:19	0	0	0099.9	0054.5	0008.6	0228.4	0019.2	0995.0	1006.0	0853.0	0027.5	0982.8
12:00:20	0	0	0099.9	0054.5	0008.6	0228.4	0019.2	0995.0	1006.0	0853.0	0027.5	0982.8
12:00:21	0	0	0099.9	0054.5	0008.6	0228.4	0019.2	0995.0	1006.0	0853.0	0027.5	0982.8
12:00:22	0	0	0099.9	0054.5	0008.6	0228.4	0019.2	0995.0	1006.0	0853.0	0027.5	0983.1
12:00:23	0	0	0099.9	0054.5	0008.6	0228.4	0019.2	0995.0	1006.0	0853.0	0027.5	0982.8
12:00:24	0	0	0099.9	0054.5	0008.6	0228.4	0019.2	0995.0	1006.0	0853.0	0027.5	0983.1
12:00:25	0	0	0099.9	0054.5	0008.6	0228.4	0019.2	0995.0	1006.0	0853.0	0027.5	0983.1
12:00:26	0	0	0099.9	0054.5	0008.6	0228.4	0019.2	0995.0	1006.0	0853.0	0027.5	0983.4
12:00:27	0	0	0099.9	0054.5	0008.6	0228.4	0019.2	0995.0	1006.0	0853.0	0027.5	0983.7
12:00:28	0	0	0099.9	0054.5	0008.6	0228.4	0019.2	0995.0	1006.0	0853.0	0027.5	0983.7
12:00:29	0	0	0099.9	0054.5	0008.6	0228.4	0019.2	0995.0	1006.0	0853.0	0027.5	0983.4
12:00:30	0	0	0099.9	0054.5	0008.6	0228.4	0019.2	0995.0	1006.0	0853.0	0027.5	0983.7
12:00:31	0	0	0099.9	0054.5	0008.6	0228.4	0019.2	0995.0	1006.0	0853.0	0027.5	0984.0
12:00:32	0	0	0099.9	0054.5	0008.6	0228.4	0019.2	0995.0	1006.0	0853.0	0027.5	0984.0
12:00:33	0	0	0099.9	0054.5	0008.6	0228.4	0019.2	0995.0	1006.0	0853.0	0027.5	0983.7
12:00:34	0	0	0099.9	0054.5	0008.6	0228.4	0019.2	0995.0	1006.0	0853.0	0027.5	0983.7
12:00:35	0	0	0099.9	0054.5	0008.6	0228.4	0019.2	0995.0	1006.0	0853.0	0027.5	0983.7
12:00:36	0	0	0099.9	0054.5	0008.6	0228.4	0019.2	0995.0	1006.0	0853.0	0027.5	0983.7
12:00:37	0	0	0099.9	0054.5	0008.6	0228.4	0019.2	0995.0	1006.0	0853.0	0027.5	0985.2
12:00:38	0	0	0099.9	0054.5	0008.6	0228.4	0019.2	0995.0	1006.0	0853.0	0027.5	0984.9
12:00:39	0	0	0099.9	0054.5	0008.6	0228.4	0019.2	0995.0	1006.0	0853.0	0027.5	0984.6
12:00:40	0	0	0099.9	0054.5	0008.6	0228.4	0019.2	0995.0	1006.0	0853.0	0027.5	0984.9
12:00:41	0	0	0099.9	0054.5	0008.6	0228.4	0019.2	0995.0	1006.0	0853.0	0027.5	0984.9
12:00:42	0	0	0099.9	0054.5	0008.6	0228.4	0019.2	0995.0	1006.0	0853.0	0027.5	0984.9
12:00:43	0	0	0099.9	0054.5	0008.6	0228.4	0019.2	0995.0	1006.0	0853.0	0027.5	0984.3
12:00:44	0	0	0099.9	0054.5	0008.6	0228.4	0019.2	0995.0	1006.0	0853.0	0027.5	0984.6
12:00:45	0	0	0099.9	0054.5	0008.6	0228.4	0019.2	0995.0	1006.0	0853.0	0027.5	0984.9
12:00:46	0	0	0099.9	0054.5	0008.6	0228.4	0019.2	0995.0	1006.0	0853.0	0027.5	0985.4
12:00:47	0	0	0099.9	0054.5	0008.6	0228.4	0019.2	0995.0	1006.0	0853.0	0027.5	0985.7
12:00:48	0	0	0099.9	0054.5	0008.6	0228.4	0019.2	0995.0	1006.0	0853.0	0027.5	0985.4
12:00:49	0	0	0099.9	0054.5	0008.6	0228.4	0019.2	0995.0	1006.0	0853.0	0027.5	0985.4
12:00:50	0	0	0099.9	0054.5	0008.6	0228.4	0019.2	0995.0	1006.0	0853.0	0027.5	0985.2
12:00:51	0	0	0099.9	0055.0	0007.9	0246.2	0019.2	0995.0	1005.0	0852.0	0027.5	0985.2
12:00:52	0	0	0099.9	0055.0	0007.9	0246.2	0019.2	0995.0	1005.0	0852.0	0027.5	0985.4
12:00:53	0	0	0099.9	0055.0	0007.9	0246.2	0019.2	0995.0	1005.0	0852.0	0027.5	0985.7

Table B-6. (Cont'd)

PRINT: 06R

FACC SMALL COMMUNITY SOLAR EXPERIMENT  
DATE: 03/03/82

PAGE: 0001

TIME	RLS	WLS	PYRHL3 W/M*M	GCALC * KW
12:00:00	0	0	0985.5	0050.3
12:00:01	0	0	0985.5	0038.4
12:00:02	0	0	0985.5	0047.3
12:00:03	0	0	0985.5	0041.4
12:00:04	0	0	0985.5	0048.8
12:00:05	0	0	0985.5	0045.8
12:00:06	0	0	0985.5	0048.8
12:00:07	0	0	0985.5	0047.3
12:00:08	0	0	0985.5	0039.9
12:00:09	0	0	0985.5	0041.4
12:00:10	0	0	0985.5	0039.9
12:00:11	0	0	0985.5	0039.9
12:00:12	0	0	0985.5	0047.3
12:00:13	0	0	0985.5	0039.9
12:00:14	0	0	0985.5	0041.4
12:00:15	0	0	0985.5	0044.4
12:00:16	0	0	0985.5	0039.9
12:00:17	0	0	0985.5	0039.9
12:00:18	0	0	0985.5	0047.3
12:00:19	0	0	0985.5	0048.8
12:00:20	0	0	0985.5	0042.9
12:00:21	0	0	0985.5	0042.9
12:00:22	0	0	0985.5	0038.4
12:00:23	0	0	0985.5	0047.3
12:00:24	0	0	0985.5	0047.3
12:00:25	0	0	0985.5	0039.9
12:00:26	0	0	0985.5	0045.8
12:00:27	0	0	0985.5	0048.8
12:00:28	0	0	0985.5	0034.0
12:00:29	0	0	0985.5	0045.8
12:00:30	0	0	0985.5	0044.4
12:00:31	0	0	0985.5	0047.3
12:00:32	0	0	0985.5	0045.8
12:00:33	0	0	0985.5	0047.3
12:00:34	0	0	0985.5	0047.3
12:00:35	0	0	0985.5	0045.8
12:00:36	0	0	0985.5	0042.9
12:00:37	0	0	0985.5	0039.9
12:00:38	0	0	0985.5	0039.9
12:00:39	0	0	0985.5	0048.8
12:00:40	0	0	0985.5	0034.0
12:00:41	0	0	0985.5	0048.8
12:00:42	0	0	0985.5	0045.8
12:00:43	0	0	0985.5	0037.0
12:00:44	0	0	0985.5	0041.4
12:00:45	0	0	0985.5	0041.4
12:00:46	0	0	0985.5	0047.3
12:00:47	0	0	0985.5	0045.8
12:00:48	0	0	0985.5	0044.4
12:00:49	0	0	0985.5	0048.8
12:00:50	0	0	0985.5	0048.8
12:00:51	0	0	0982.9	0045.8
12:00:52	0	0	0982.9	0044.4
12:00:53	0	0	0982.9	0044.4

\*Not valid for these tests

PRINT 08 DESCRIPTION - PCS PERFORMANCE DATA

<u>Print No.</u>	<u>Parameter*</u>	<u>Description</u>
08L	TRINPR	Turbine inlet pressure
08L	TRINTP	Turbine inlet temperature
08L	RLEXTP	Regenerator liquid exit temperature
08L	SYOTPR	System (feed) pump exit pressure
08L	TREXPR	Turbine exit pressure
08L	TREXTP	Turbine exit temperature
08L	RCOTTP	Receiver fluid outlet temp
08L	RCOTPR	Receiver fluid outlet pressure
08L	PM4	Power available to PCS
08L	PM5	Power out of PCS
-----		
08R	CNINTP	Condenser inlet temperature
08R	CNEXTP	Condenser exit temperature
08R	CNEXPR	Condenser exit pressure
08R	RLINTP	Regenerator liquid inlet temperature
08R	SYINPR	System (feed) pump inlet pressure
08R	TRVLP	Vapor valve position
08R	TURPM	Turbine speed
08R	RESLVL	Reservoir fluid level
08R	DSEVT1	RCIA discrete events No. 1
08R	DSEVT2	RCIA discrete events No. 2

\*All parameters on this print are repeats, primarily from Prints 02 and 03.

Table B-7. Printout of 08 for Run 13

PRINT: OBL

FACC SMALL COMMUNITY SOLAR EXPERIMENT  
DATE: 03/03/82

PAGE: 0001

TIME	RLS	WLS	TRINPR PSIA	TRINTP DEG F	RLEXTF DEG F	SYOTPR PSIA	TREXPR PSIA	TREXTP DEG F	RCOTTP DEG F	RCOTPR PSIA	PM4 KW	PM5 KW
12:00:00	0	0	0410.8	0745.2	0380.4	0527.6	0001.5	0517.6	0750.4	0494.0	0070.8	0016.2
12:00:01	0	0	0416.0	0741.6	0378.4	0528.4	0001.5	0517.6	0750.0	0494.0	0072.2	0016.3
12:00:02	0	0	0410.0	0741.6	0378.4	0528.0	0001.5	0517.6	0750.4	0493.6	0071.2	0016.4
12:00:03	0	0	0410.4	0743.6	0378.8	0528.0	0001.5	0517.6	0750.4	0494.4	0071.1	0016.1
12:00:04	0	0	0409.6	0744.0	0377.6	0527.2	0001.5	0517.6	0750.4	0494.4	0071.0	0016.1
12:00:05	0	0	0413.2	0741.6	0378.4	0528.8	0001.5	0517.6	0750.4	0494.4	0071.8	0016.0
12:00:06	0	0	0410.8	0743.6	0378.4	0528.8	0001.5	0517.6	0750.4	0494.4	0071.1	0016.1
12:00:07	0	0	0410.8	0743.6	0378.8	0528.8	0001.5	0517.6	0749.6	0494.4	0071.2	0016.2
12:00:08	0	0	0410.8	0743.6	0378.0	0528.4	0001.5	0517.6	0750.8	0494.4	0071.2	0016.2
12:00:09	0	0	0411.2	0743.6	0378.8	0528.4	0001.5	0518.0	0749.6	0494.4	0071.2	0016.3
12:00:10	0	0	0414.4	0743.6	0378.8	0529.2	0001.5	0518.0	0750.4	0493.6	0071.8	0016.2
12:00:11	0	0	0412.8	0743.6	0378.4	0528.0	0001.5	0517.6	0748.0	0493.6	0071.2	0016.2
12:00:12	0	0	0417.6	0744.0	0378.4	0528.8	0001.5	0518.0	0750.0	0494.0	0072.3	0016.3
12:00:13	0	0	0411.6	0744.0	0378.4	0528.4	0001.5	0518.0	0750.4	0494.8	0071.3	0016.2
12:00:14	0	0	0410.8	0745.2	0378.4	0528.0	0001.5	0517.6	0750.4	0494.8	0071.1	0016.1
12:00:15	0	0	0410.4	0743.6	0378.4	0528.0	0001.5	0517.6	0750.4	0494.4	0071.1	0016.0
12:00:16	0	0	0409.6	0743.6	0378.4	0528.0	0001.5	0517.2	0750.4	0494.8	0071.0	0016.2
12:00:17	0	0	0414.0	0743.6	0379.2	0527.6	0001.5	0517.6	0750.4	0494.0	0071.8	0016.1
12:00:18	0	0	0410.4	0743.6	0378.4	0528.4	0001.5	0518.0	0750.4	0492.0	0071.2	0016.0
12:00:19	0	0	0410.8	0743.6	0378.4	0527.6	0001.5	0517.6	0750.4	0493.6	0071.1	0016.0
12:00:20	0	0	0402.8	0743.6	0378.4	0527.6	0001.5	0517.6	0750.8	0493.2	0069.7	0016.4
12:00:21	0	0	0415.6	0743.6	0379.2	0528.4	0001.5	0519.6	0750.4	0493.6	0071.9	0016.1
12:00:22	0	0	0410.4	0741.6	0378.4	0527.6	0001.5	0518.0	0750.4	0494.4	0071.2	0016.4
12:00:23	0	0	0414.4	0743.6	0378.4	0529.2	0001.5	0517.6	0750.0	0494.0	0071.8	0016.3
12:00:24	0	0	0410.8	0743.6	0379.6	0528.4	0001.5	0518.0	0749.6	0494.4	0070.9	0016.1
12:00:25	0	0	0413.6	0741.6	0378.4	0528.4	0001.5	0518.0	0750.4	0494.4	0072.1	0016.1
12:00:26	0	0	0410.8	0741.6	0378.0	0528.4	0001.5	0518.4	0750.4	0494.4	0071.3	0016.3
12:00:27	0	0	0406.0	0744.0	0378.4	0527.2	0001.5	0517.6	0750.4	0494.4	0070.4	0016.3
12:00:28	0	0	0412.4	0743.6	0379.2	0528.4	0001.5	0518.0	0750.0	0494.4	0071.3	0016.2
12:00:29	0	0	0410.8	0743.6	0378.4	0528.0	0001.5	0517.6	0749.6	0494.4	0071.0	0016.4
12:00:30	0	0	0406.0	0740.8	0378.8	0527.2	0001.5	0518.0	0750.0	0493.6	0070.6	0016.2
12:00:31	0	0	0410.8	0741.6	0378.4	0528.0	0001.5	0518.0	0750.4	0494.4	0071.2	0016.2
12:00:32	0	0	0412.8	0741.6	0379.6	0528.8	0001.5	0518.0	0750.0	0494.8	0071.4	0016.1
12:00:33	0	0	0409.2	0743.6	0379.2	0528.4	0001.5	0518.0	0750.4	0494.8	0070.9	0016.1
12:00:34	0	0	0410.8	0741.6	0379.2	0528.4	0001.5	0518.4	0750.0	0494.8	0071.1	0016.2
12:00:35	0	0	0410.8	0741.6	0378.4	0528.8	0001.5	0518.0	0750.0	0494.4	0071.2	0016.4
12:00:36	0	0	0418.8	0741.6	0379.2	0528.8	0001.5	0518.0	0749.6	0493.6	0072.5	0016.0
12:00:37	0	0	0415.6	0741.6	0379.2	0529.2	0001.5	0516.8	0749.6	0494.4	0071.9	0016.1
12:00:38	0	0	0412.4	0743.6	0379.2	0527.6	0001.5	0518.0	0750.4	0493.6	0071.4	0016.5
12:00:39	0	0	0410.8	0743.6	0378.4	0528.8	0001.5	0517.6	0750.0	0494.8	0071.1	0016.8
12:00:40	0	0	0418.0	0741.6	0378.4	0528.8	0001.5	0518.0	0749.6	0494.4	0072.5	0016.1
12:00:41	0	0	0419.6	0743.6	0379.2	0528.8	0001.5	0518.0	0750.0	0493.6	0072.6	0016.3
12:00:42	0	0	0412.4	0743.6	0378.4	0527.6	0001.5	0518.0	0749.6	0494.0	0071.4	0016.7
12:00:43	0	0	0412.4	0743.6	0379.2	0527.6	0001.5	0518.0	0750.0	0494.4	0071.3	0016.2
12:00:44	0	0	0415.6	0741.6	0379.2	0527.6	0001.5	0518.4	0749.6	0494.0	0071.9	0015.9
12:00:45	0	0	0410.8	0743.6	0379.2	0529.2	0001.5	0518.0	0750.0	0494.8	0071.0	0016.7
12:00:46	0	0	0406.8	0743.6	0378.4	0527.6	0001.5	0518.0	0749.6	0492.0	0070.3	0016.4
12:00:47	0	0	0413.6	0741.6	0379.6	0527.6	0001.5	0517.6	0749.6	0494.0	0071.5	0016.0
12:00:48	0	0	0413.2	0743.6	0378.4	0528.4	0001.5	0517.6	0749.6	0494.4	0071.6	0017.0
12:00:49	0	0	0411.2	0743.6	0378.4	0528.4	0001.5	0518.0	0749.6	0492.4	0071.2	0016.3
12:00:50	0	0	0418.8	0743.6	0379.2	0528.0	0001.5	0517.6	0749.6	0493.6	0072.4	0016.0
12:00:51	0	0	0410.8	0741.6	0379.2	0529.2	0001.5	0518.0	0751.6	0493.2	0071.3	0015.7
12:00:52	0	0	0409.6	0741.6	0378.4	0527.6	0001.5	0518.0	0749.2	0494.8	0070.9	0016.0
12:00:53	0	0	0406.0	0740.8	0378.4	0528.0	0001.5	0518.0	0749.6	0494.8	0070.4	0016.0

Table B-7. (Cont'd)

PRINT: OBR

FACC SMALL COMMUNITY SOLAR EXPERIMENT  
DATE: 03/03/82

PAGE: 0001

TIME	RLS	WLS	CNINTP DEG F	CNEXTP DEG F	CNEXPR PSIA	RLINTP DEG F	BYINPR PSIA	TRVLP PERCENT	TURPM KRPM	REBLVL PERCENT	DSEVT1 EVENTS	DSEVT2 EVENTS
12:00:00	0	0	0172.9	0082.8	0001.1	0091.6	0027.8	0047.3	0047.6	0078.2	00000110	01011100
12:00:01	0	0	0172.6	0082.8	0001.1	0091.7	0027.4	0047.7	0047.6	0078.0	00000110	01011100
12:00:02	0	0	0173.0	0082.6	0001.1	0091.7	0027.8	0047.2	0047.6	0078.3	00000110	01011100
12:00:03	0	0	0173.0	0082.7	0001.1	0091.7	0027.7	0047.4	0047.6	0078.3	00000110	01011100
12:00:04	0	0	0173.0	0082.6	0001.1	0091.7	0027.8	0047.4	0047.6	0078.1	00000110	01011100
12:00:05	0	0	0173.0	0082.7	0001.1	0091.7	0027.4	0047.4	0047.6	0077.7	00000110	01011100
12:00:06	0	0	0173.2	0082.6	0001.1	0091.4	0027.6	0047.4	0047.6	0078.1	00000110	01011100
12:00:07	0	0	0173.2	0082.6	0001.1	0091.7	0027.7	0047.2	0047.6	0078.3	00000110	01011100
12:00:08	0	0	0173.2	0082.6	0001.1	0091.5	0027.8	0047.3	0047.6	0077.8	00000110	01011100
12:00:09	0	0	0173.0	0082.6	0001.1	0091.5	0027.5	0047.3	0047.6	0077.0	00000110	01011100
12:00:10	0	0	0173.5	0082.6	0001.1	0091.5	0027.5	0047.6	0047.6	0077.4	00000110	01011100
12:00:11	0	0	0173.0	0082.5	0001.1	0091.4	0027.6	0047.4	0047.6	0077.7	00000110	01011100
12:00:12	0	0	0173.1	0082.5	0001.1	0091.4	0027.7	0047.7	0047.8	0077.7	00000110	01011100
12:00:13	0	0	0173.2	0082.4	0001.1	0091.0	0027.9	0047.4	0047.6	0077.4	00000110	01011100
12:00:14	0	0	0173.2	0082.4	0001.1	0091.4	0027.7	0047.4	0047.6	0076.7	00000110	01011100
12:00:15	0	0	0173.4	0082.5	0001.1	0091.5	0027.8	0047.4	0047.6	0077.4	00000110	01011100
12:00:16	0	0	0173.4	0082.7	0001.1	0091.3	0027.8	0047.3	0047.6	0077.7	00000110	01011100
12:00:17	0	0	0173.3	0082.4	0001.1	0091.4	0027.7	0047.6	0047.6	0077.0	00000110	01011100
12:00:18	0	0	0173.2	0082.2	0001.1	0091.3	0027.8	0047.4	0047.8	0077.0	00000110	01011100
12:00:19	0	0	0173.3	0082.3	0001.1	0091.3	0027.8	0047.4	0047.6	0077.5	00000110	01011100
12:00:20	0	0	0173.5	0082.3	0001.1	0091.2	0028.0	0046.6	0047.4	0077.8	00000110	01011100
12:00:21	0	0	0173.4	0082.3	0001.1	0091.3	0027.7	0047.6	0047.8	0077.1	00000110	01011100
12:00:22	0	0	0173.5	0082.1	0001.1	0091.2	0027.8	0047.4	0047.6	0078.0	00000110	01011100
12:00:23	0	0	0173.6	0082.1	0001.1	0091.1	0027.6	0047.6	0047.6	0078.8	00000110	01011100
12:00:24	0	0	0173.7	0082.2	0001.1	0091.1	0027.6	0047.3	0047.6	0077.3	00000110	01011100
12:00:25	0	0	0173.9	0082.3	0001.1	0091.0	0027.8	0047.6	0047.6	0077.1	00000110	01011100
12:00:26	0	0	0174.2	0082.1	0001.1	0091.0	0027.8	0047.4	0047.6	0077.5	00000110	01011100
12:00:27	0	0	0173.8	0082.1	0001.1	0091.0	0027.8	0047.1	0047.6	0077.2	00000110	01011100
12:00:28	0	0	0174.0	0082.0	0001.1	0091.0	0027.7	0047.4	0047.8	0077.2	00000110	01011100
12:00:29	0	0	0173.8	0082.1	0001.1	0091.0	0027.7	0047.3	0047.6	0077.3	00000110	01011100
12:00:30	0	0	0173.6	0082.1	0001.1	0091.1	0027.8	0047.0	0047.6	0077.1	00000110	01011100
12:00:31	0	0	0173.5	0082.1	0001.1	0090.9	0027.7	0047.4	0047.6	0077.3	00000110	01011100
12:00:32	0	0	0173.5	0082.1	0001.1	0091.1	0027.9	0047.6	0047.6	0077.4	00000110	01011100
12:00:33	0	0	0173.4	0082.0	0001.1	0090.9	0027.8	0047.2	0047.6	0077.0	00000110	01011100
12:00:34	0	0	0173.4	0082.3	0001.1	0090.9	0027.7	0047.4	0047.6	0076.9	00000110	01011100
12:00:35	0	0	0173.3	0081.9	0001.1	0090.8	0027.9	0047.4	0047.6	0077.0	00000110	01011100
12:00:36	0	0	0173.4	0081.9	0001.1	0090.9	0027.6	0048.0	0047.8	0077.8	00000110	01011100
12:00:37	0	0	0173.5	0082.0	0001.1	0090.7	0027.6	0047.4	0047.6	0077.7	00000110	01011100
12:00:38	0	0	0173.5	0081.9	0001.1	0090.9	0027.8	0047.4	0047.6	0077.0	00000110	01011100
12:00:39	0	0	0173.3	0081.9	0001.1	0090.8	0027.7	0047.4	0047.6	0077.1	00000110	01011100
12:00:40	0	0	0173.3	0081.9	0001.1	0090.7	0027.5	0047.7	0047.8	0077.2	00000110	01011100
12:00:41	0	0	0173.5	0081.8	0001.1	0090.8	0027.3	0047.8	0047.8	0077.0	00000110	01011100
12:00:42	0	0	0173.6	0082.3	0001.1	0090.6	0028.0	0047.4	0047.6	0077.4	00000110	01011100
12:00:43	0	0	0173.5	0081.8	0001.1	0090.7	0027.8	0047.6	0047.6	0077.7	00000110	01011100
12:00:44	0	0	0173.5	0081.8	0001.1	0090.6	0027.5	0047.4	0047.6	0076.7	00000110	01011100
12:00:45	0	0	0173.6	0082.0	0001.1	0090.9	0027.7	0047.4	0047.6	0077.0	00000110	01011100
12:00:46	0	0	0173.5	0081.8	0001.1	0090.6	0027.9	0047.0	0047.6	0077.5	00000110	01011100
12:00:47	0	0	0173.5	0081.6	0001.1	0090.7	0027.4	0047.4	0047.6	0076.9	00000110	01011100
12:00:48	0	0	0173.3	0081.8	0001.1	0090.6	0027.5	0047.4	0047.8	0076.9	00000110	01011100
12:00:49	0	0	0172.6	0081.8	0001.1	0090.5	0027.5	0047.3	0047.6	0076.6	00000110	01011100
12:00:50	0	0	0174.3	0081.9	0001.1	0090.5	0027.3	0047.7	0047.6	0077.1	00000110	01011100
12:00:51	0	0	0172.9	0081.8	0001.1	0090.5	0027.7	0047.4	0047.6	0077.2	00000110	01011100
12:00:52	0	0	0173.0	0081.4	0001.1	0090.2	0027.9	0047.2	0047.6	0077.0	00000110	01011100
12:00:53	0	0	0173.1	0081.8	0001.1	0090.5	0027.9	0047.0	0047.6	0077.1	00000110	01011100

## REFERENCES

- B-1. Clark, T.B., Power/Energy/Efficiency Calculations for the TBC PDS Tests - Program OPWEG, FACC TR SCSE-044A, January 29, 1982.
- B-2. Fish, V. and Kramer, R.M., Data Lists for the SCSE Links, FACC TR SCSE-027E, January 25, 1982.
- B-3. Kramer, R.M., SCSE Operational Computer Programs Product Specification, FACC Specification No. AS2000211, March 1, 1982.

## APPENDIX C

### DOCUMENTATION

During the course of this program many documents were generated in fulfillment of contractual obligations or for internal control or record keeping. Monthly progress reports were issued that summarized work completed in a given period, often with appendices reporting a specific technical effort. The latter documents were usually called TRs (Technical Reports). The following is a listing of significant documents.

## SPECIFICATIONS

APSI49487      Brazing and Finishing of Copper Solar Receiver

AS147438      Critical Item Development Specification for the SCSE Power Conversion Subsystem (PCS)

AS147633      Performance Specification 30 KVA Inverter

AS148588      Prime Item Development Specification for the Small Community Solar Thermal Power Experiment (SCSE)

AS149027      Master Power Controller (MPC) and Central Control Interface Assembly (CCIA) System Specification for the Small Community Solar Thermal Power Experiment (SCSE)

AS149029      Remote Control Interface Assembly (RCIA) Specification for the Small Community Solar Thermal Power Experiment (SCSE)

AS149495      Critical Item Development Specification for the SCSE Receiver Subassembly

AS2000149      Critical Item Development Specification for the SCSE Control Subsystem

AS2000211      Volume 1: SCSE Operational Computer Programs Products Specification

                 Volume 11: Master Operational Program (MOP) Listing

                 Volume 111: Remote Operational Program (ROP) Listing

AS2000503      Performance Specification SCSE Switchboard

AS2000932      Procurement Specification SCSE Switchboard, Phase III SCSE<sup>1</sup>

AS2000933      Critical Item Development Specification - SCSE Inverter(s), Phase III<sup>1</sup>

AS2001116      Prime Item Development Specification for the Small Community Solar Thermal Power Experiment (SCSE), Phase III<sup>1</sup>

AS2001117      SCSE Site Specification, Osage City, Kansas

---

<sup>1</sup>These specifications are unreleased by FACC. They were part of the Phase III program and apply to the four (25-kWe) module - 100 kW plant.



SPECIFICATIONS (Cont'd.)

AS2001185      Critical Item Development Specification for the Parabolic  
Dish Concentrator-2 (PDC-2)

AS2001377      Critical Item Product Specification - SCSE Receiver  
Subassembly<sup>1</sup>

AS2001378      Critical Item Product Specification - SCSE Power Conversion  
Subsystem (PCS)<sup>1</sup>

---

<sup>1</sup>These specifications are unreleased by FACC. They were part of the Phase III program and apply to the four (25-kWe) module - 100 kW plant.

TECHNICAL REPORTS

<u>Technical Report No.</u>	<u>Title</u>	<u>Date</u>	<u>Reference<sup>2</sup> Monthly Progress</u>
SCSE-001	SCSE Inverter Requirements Trade-offs	1/25/80	1 (Appendix A)
SCSE-002	Preliminary Energy Transport System Selection	1/30/80	1 (Appendix B)
SCSE-003	Preliminary Receiver Baseline Parameters	-	2 (Appendix A)
SCSE-003A	Preliminary Receiver Baseline Parameters (Revised)	2/29/80	4 (Appendix A)
SCSE-004	SCSE Measurement list	4/30/80	4 (Appendix B)
SCSE-004A	SCSE Measurement List	8/25/80	8 (Appendix A)
SCSE-005	SCSE Master Power Controller (MPS) Software-Related Requirements	5/8/80	5 (Appendix A)
SCSE-006	Preliminary Fault Tree Analysis for Phase II and Phase III	5/7/80	5 (Appendix B)
SCSE-007	Test Plan, Receiver Development Test	-	-
SCSE-007A	Test Plan, Receiver Core Development Test	10/31/80	10 (Appendix A)
SCSE-008	SCSE FACG/JPL Real Time Data Interface	5/15/80	5 (Appendix C)
SCSE-008A	SCSE FACG/JPL Real Time Data	6/17/80	(Not included in a TR)
SCSE-009	Rated Insulation for Barber-Nichols PCS	5/22/80	5 (Appendix D)
SCSE-010	Proposed Derating Criteria for Electronic/Electrical Parts	-	5 (Appendix E)
SCSE-011A	Development Plan-Power Conversion Subsystem	6/29/80	6 (Appendix A)

<sup>2</sup>Beyond Monthly Technical Progress Report No. 16 (reporting period 28 March to 2 May 1981), the TRs were published as separate documents.

TECHNICAL REPORTS (Cont'd.)

<u>Technical Report No.</u>	<u>Title</u>	<u>Date</u>	<u>Reference<sup>2</sup> Monthly Progress</u>
SCSE-012	SCSE RCIA Processor Software-Related Requirements (Preliminary)	6/13/80	6 (Appendix B)
SCSE-013	SCSE PCA Installation Procedure	-	(Not included in a TR)
SCSE-014	Inverter Control Methods and PCS Electrical Matching Characteristics	9/15/80	9 (Appendix A)
SCSE-015	SCSE System Performance Sensitivity Analysis	7/11/80	7 (Appendix A)
SCSE-016	"CAV" Code for the Determination of incident Flux Distribution in an Axisymmetrical Cavity From a Paraboloid Reflector	7/15/80	7 (Appendix B)
SCSE-017	"CVT" Code for the Determination of Temperature Distribution in an Axisymmetrical Cavity	7/24/80	7 (Appendix C)
SCSE-018	Phase II Procurement and Fabrication Plan (Preliminary)	7/15/80	7 (Appendix D)
SCSE-018A	Phase II Procurement and Fabrication Plan	11/6/80	11 (Appendix A)
SCSE-019	Electrical Cable Characteristics PCS to Rectifier	10/10/80	11 (Appendix B)
SCSE-020	SCSE PCA Digital Control System Description and Requirements	8/11/80	8 (Appendix B)
SCSE-021	SCSE Status Panels	8/22/80	9 (Appendix B)
SCSE-022	Hazardous Area Classification and Definitions for SCSE Program Electrical System	9/23/80	9 (Appendix C)

---

<sup>2</sup>Beyond Monthly Technical Progress Report No. 16 (reporting period 28 March to 2 May 1981), the TRs were published as separate documents.

TECHNICAL REPORTS (Cont'd.)

<u>Technical Report No.</u>	<u>Title</u>	<u>Date</u>	<u>Reference<sup>2</sup> Monthly Progress</u>
SCSE-023	Solar Energy Computer Codes-System Analysis	11/18/80	12 (Appendix A)
SCSE-024	Engineering Unit Scaling and DAC/ADC Conversions in SCSE Software	12/2/80	12 (Appendix B)
SCSE-025	SCSE MPC CRT Display and Printout	11/26/80	12 (Appendix B)
SCSE-026	FACC Solar Receiver Oxidation/Corrosion Tests	11/17/80	11 (Appendix C)
SCSE-027	Data Lists for the SCSE Links	12/8/80	12 (Appendix D)
SCSE-027A	Data Lists for the SCSE Links	2/5/81	(Rec. at SDR)
SCSE-027B	Data Lists for the SCSE Links	4/22/81	16 (Appendix A)
SCSE-027C	Data Lists for the SCSE Links	6/24/81	-
SCSE-027D	Data Lists for the SCSE Links	9/2/81	-
SCSE-028	Definition of Phase III Control Subsystem Operating Modes		(In progress)
SCSE-029	Receiver/Engine Dynamic Analysis	7/29/81	-
SCSE-030	Preliminary Parts and Suppliers List	12/12/80	12 (Appendix E)
SCSE-031	SCSE Control Subsystem Description	12/16/80	12 (Appendix F)
SCSE-032	Turbine/Inverter Dynamic Stability Analysis	5/11/81	-
SCSE-033	SCSE Software Documentation Definition and Guidelines	12/17/80	12 (Appendix G)
SCSE-034	Preliminary Hazard Analysis	2/9/81	14 (Appendix A)
SCSE-035	Recommended Lightning Protection for SCSE Equipment	2/19/81	14 (Appendix B)

<sup>2</sup>Beyond Monthly Technical Progress Report No. 16 (reporting period 28 March to 2 May 1981), the TRs were published as separate documents.

TECHNICAL REPORTS (Cont'd)

<u>Technical Report No.</u>	<u>Title</u>	<u>Date</u>	<u>Reference<sup>2</sup> Monthly Progress</u>
SCSE-036	Typical Field Layouts for a Phase III Plant	2/19/81	14 (Appendix C)
SCSE-037	Failure Mode and Effects Analysis for the Small Community Thermal Power Experiment	3/6/81	15 (Appendix A)
SCSE-038	Availability Prediction for the Small Community Thermal Power Experiment	3/6/81	15 (Appendix B)
SCSE-039	PCS Control Requirements (Draft)	4/1/81	16 (Appendix B)
SCSE-039B	PCS Control Requirements	2/2/83	-
SCSE-040	Aperture Plate Thermal Analysis	5/29/81	-
SCSE-042	Test Results for the Development Receiver Core	6/11/81	-
SCSE-043	Aperture Plate Thermal Stress Analysis	6/11/81	-
SCSE-044	Power/Energy/Efficiency Calculations for the TBC PDTS Tests - Program OPWEG	9/17/81	-
SCSE-045	Data Playback Program Requirements	10/5/81	-
SCSE-046	Data Playback Program Operation and Use	11/16/81	-
SCSE-047	Requirements for a Plot Playback Program	9/15/81	-

---

<sup>2</sup>Beyond Monthly Technical Progress Report No. 16 (reporting period 28 March to 2 May 1981), the TRs were published as separate documents.

## OTHER REPORTS

SCSE Report No. 001 (Revision A)	Small Community Solar Thermal Power Experiment System Description Document (Draft)	10/8/80
(No number)	Receiver Selection Methodology	6/3/80
IOM SCSTPE- 80-002	Nomenclature and Definitions for the Small Community Solar Thermal Power Equipment	1/15/80
SCSE Report No. 012	Small Community Solar Thermal Power Experiment (SCSE) Preliminary Design Study for Verification of SCSE Elements on the TBC	4/21/81
SCSE Report No. 014	Test Results Summary for Receiver Qualification Tests (DCRL No. 33)	6/29/81
SCSE Report No. 015	Test Report: Receiver Qualification Tests (CDRL No. 34)	8/6/81
SCSE Report No. 016	Test Results Summary for Control Subsystem Qualification Tests (CDRL No. 33)	8/6/81
SCSE Report No. 017	Test Report: Control Subsystem Qualification Tests (CDRL No. 34)	8/26/81
SCSE Report No. 018	Test Results Summary for the Inverter Acceptance Test	9/11/81
SCSE Report No. 019	Test Results Summary for the Switchboard Acceptance Test	9/29/81
SCSE Report No. 020	Test Results Summary for Power Conversion Subsystem (PCS) Qualification Tests	10/26/81
Task II Report	Final Report, Evaluation of Carter Reciprocator Steam Engine (CDRL No. 40)	5/81
SCSE Report No. 021	Test Results Summary for PCS/RCR Compatibility Test	1/14/82
SCSE Report No. 022	PCS/RCR Compatibility Tests at FACC	4/16/82