

A Review of the Salt-Gradient Solar Pond Technology

E.I.H. Lin

January 30, 1982

Prepared for
U.S. Department of Energy
Through an Agreement with
National Aeronautics and Space Administration
by
Jet Propulsion Laboratory
California Institute of Technology
Pasadena, California

(JPL PUBLICATION 81-116)

A REVIEW OF THE SALT-GRADIENT
SOLAR POND TECHNOLOGY

E. I. H. Lin

JANUARY 30, 1982

Prepared for
U.S. Department of Energy
Through an agreement with
National Aeronautics and Space Administration

By

Jet Propulsion Laboratory
California Institute of Technology
Pasadena, California

Prepared by the Jet Propulsion Laboratory, California Institute of Technology, for the U.S. Department of Energy through an agreement with the National Aeronautics and Space Administration.

The JPL Solar Ponds Project is sponsored by the U.S. Department of Energy and is part of the Solar Thermal Program to develop solar pond technology.

This report was prepared as an account of work sponsored by an agency of the United States Government. Neither the United States Government nor any agency thereof, nor any of their employees, makes any warranty, express or implied, or assumes any legal liability or responsibility for the accuracy, completeness, or usefulness of any information, apparatus, product, or process disclosed, or represents that its use would not infringe privately owned rights.

Reference herein to any specific commercial product, process, or service by trade name, trademark, manufacturer, or otherwise, does not necessarily constitute or imply its endorsement, recommendation, or favoring by the United States Government or any agency thereof. The views and opinions of authors expressed herein do not necessarily state or reflect those of the United States Government or any agency thereof.

ABSTRACT

The state of the salt-gradient solar pond technology is reviewed. Highlights of findings and experiences from existing ponds to date are presented, and the behavior, energy yield, operational features, and economics of solar ponds are examined. It is concluded that salt-gradient solar ponds represent a technically feasible, environmentally benign, and economically attractive energy producing alternative. In order to bring this emerging technology to maturity, however, much research and development effort remains to be undertaken. Specific R&D areas requiring the attention and action of technical workers and decision-makers are discussed, both from the perspectives of smaller, thermally-oriented ponds and larger, electricity generating ponds.

ACKNOWLEDGEMENTS

This report was written based on a presentation which the author gave at a conference, entitled "Solar Ponds: The Salt-Gradient Concept for Thermal and Electric Energy," held on April 23-24, 1981, at the California Institute of Technology, Pasadena. The conference was organized for the Institute's industrial associates whose participation in the Caltech and JPL activities and whose interest in the emerging solar pond technology are much appreciated. Many thanks are due to the Caltech and JPL personnel who organized or supported the conference.

The author is indebted to Messrs. R. L. French, W. A. Menard, R. J. Beale, J. C. Becker, J. L. Hesse, and Dr. M. E. Alper whose comments, encouragement, or support has been invaluable. The author also wishes to thank Ms. C. Boccardi who provided editorial assistance and Ms. H. Hill who typed the manuscript.

This work was performed through NASA Task RD 152, Amendment 311 and was sponsored by the U. S. Department of Energy under Interagency Agreement DEAI03-81SF11552. The support afforded by Messrs. G. Braun, J. Rannels, and F. Wilkins of the U. S. Department of Energy has been indispensable and is gratefully acknowledged.

The U.S. and Israeli solar pond pioneers and members of the pond community are responsible for the birth and rearing of the technology. Their important contributions to the various technical areas and policy-making processes have resulted in the revelation of an attractive energy-producing alternative. Their continued efforts will be essential to the technology's maturation. This report includes a brief account of their past achievements, and highlights some aspects of their technical contributions.

CONTENTS

I.	INTRODUCTION	1-1
II.	DESCRIPTION OF A SALT-GRADIENT SOLAR POND.....	2-1
III.	THERMAL AND HYDRODYNAMIC BEHAVIOR OF EXISTING PONDS.....	3-1
	A. TEMPERATURE PROFILES.....	3-1
	B. GRADIENT STABILITY.....	3-6
	C. BOILING PHENOMENA.....	3-11
IV.	THERMAL AND ELECTRICAL ENERGY YIELD.....	4-1
	A. THERMAL ENERGY.....	4-1
	B. ELECTRIC POWER.....	4-3
V.	OPERATIONAL ASPECTS AND EXPERIENCES.....	5-1
VI.	CONSTRUCTION AND COSTS.....	6-1
	A. CONSTRUCTION.....	6-1
	B. COSTS.....	6-6
VII.	RESEARCH AND DEVELOPMENT NEEDS.....	7-1
	A. PHYSICS AND CHEMISTRY.....	7-1
	B. HYDRODYNAMICS AND HEAT TRANSFER.....	7-2
	C. DESIGN AND PERFORMANCE ANALYSIS.....	7-3
	D. CONSTRUCTION TECHNIQUES.....	7-3
	E. OPERATION AND MAINTENANCE.....	7-4
	F. APPLICATIONS.....	7-4
	G. MATERIALS.....	7-4
	H. NEW CONCEPTS.....	7-5
VIII.	CONCLUDING REMARKS.....	8-1
	REFERENCES.....	9-3

FIGURES

1.	Schematic of a Salt-Gradient Solar Pond with Typical Salinity....	2-2
	and Temperature Profile	
2.	Thermal History of the UNM Solar Pond.....	3-3
3.	Thermal Response of the UNM Pond and Adjacent Ground in 1978.....	3-4
4.	Storage-Zone Temperature History of the Miamisburg Pond.....	3-5
5.	Temperature Profile for the Farm Science Review Pond.....	3-7
6.	Temperature Profiles for the Miamisburg Pond.....	3-8
7.	Temperature Profiles for the UNM Pond.....	3-9
8.	Temperature, Salinity and Density Profiles for the OARDC Pond....	3-10
9.	Gradient-Zone Thickness Variation With Time: Miamisburg Pond....	3-12
10.	Redistribution Technique Used in the UNM Pond to Eliminate the... Convective Sublayers in the Gradient Zone	3-13
11.	Stable and Unstable Regions for Double-Diffusive Systems.....	3-14
12.	Steady Temperature Increase in the Storage Zone of the UNM..... Pond Prior to Boiling	3-16
13.	Temperature Profiles in the UNM Pond During the Months..... Preceding the Boil	3-17
14.	Temperature Profile in the UNM Pond When It Reaches Its..... Highest Temperature	3-18
15.	Temperature Profiles in the UNM Pond Following the Occurrence.... of a Large Instability in the Gradient Zone Caused by Pond Boiling	3-19
16.	Energy Balance Estimated for the 5-MW Solar Pond Power Plant..... at the Salton Sea, California	4-2
17.	Computed Thermal Performance Characteristics for a 6070-m ² Pond Located in Yankton, South Dakota	4-4
18.	Electric Power Generation From a Solar Pond.....	4-6
19.	Projected Annual Performance Profile for the 5-MW _e Salton Sea.... Solar Pond Power Plant	4-8
20.	Solar Transmittance Gain With Treatment for Unconcentrated..... Salton Sea Water (C = 0.038, ρ = 1020 kg/m ³)	5-3

FIGURES (Continued)

21.	Calculated Solar Pond Electric Power Output Using Waters with.... a Variety of Spectral Absorption Characteristics	5-3
22.	Construction Schemes on Sites with High Ground Water Table	6-2
23.	Conceptual Earthfill Dikes Schematics for the Salton Sea..... Solar Pond	6-3
24.	A Typical Cross Section Showing Salton Sea Solar and Evaporation. Ponds	6-4
25.	Conceptual Arrangement at the 5-MW _e Salton Sea Power Plant.....	6-5

TABLES

1.	Performance Data From the 150-kW Pilot Solar Pond Power Plant.... at Ein Bokek, Israel	4-7
2.	Projected Energy Yield for the 5-MW _e Salton Sea Solar Pond Power. Plant	4-7
3.	Solar Pond Cost Estimates.....	6-7

SECTION I

INTRODUCTION

A salt-gradient solar pond in its most primitive form was initially nature's creation, but man's ingenuity and conscious effort have turned it into a valuable energy-producing resource. Following von Kalecsinsky's 1902 report on Medye Lagoon in Transylvania, many natural salt-gradient lakes were discovered, and suggestions were made to exploit the principle of heat entrapment by density gradient (Ref. 1, 2 and 3). Serious development of salt-gradient solar ponds was not undertaken, however, until the mid 1970's when the threat of conventional fuels shortage began to be felt. Early investigators in the U.S. perceived the use of solar ponds in home heating and other thermal applications, while those in Israel sought to establish the pond's capability in producing electric power.

Although efforts in both countries were limited, progress was made. On the one hand, the U.S. effort succeeded in demonstrating the feasibility of using solar ponds for heating homes, swimming pools and greenhouses, and for drying grains. On the other, the Israeli effort accomplished its goal by generating 6 kW_e of electricity from the Yavne pond, and 150 kW_e from the Ein Bokek pond. Stimulated by these successes of the late 1970's, interest in solar ponds began to spread, and development activities started to expand. Recently, Israel proceeded to construct its first 5-MW_e solar pond power plant, hoping to follow it up with larger units, and eventually to convert the Dead Sea into a 2000-3000 MW_e generating facility by the end of this century. The United States also launched several new solar pond research and development (R&D) programs. One of these is the Salton Sea experiment, which aims to install a 5-MW_e solar pond power generating facility in the Imperial Valley of Southern California.

Since the solar pond technology is relatively new, knowledge of its various aspects is still confined to a small, but growing, community. It is understandable that skepticism still occasionally accompanies the new-found enthusiasm. However, it must be recognized that this enthusiasm is based on the knowledge gained and experience accumulated by devoted pond researchers and developers of the recent past (Ref. 1 through 12).

One objective of this report is to summarize in a comprehensive manner the highlights of this body of knowledge and experience. A second objective is to examine the behavior, energy yield, operational features, and economics of solar ponds, based on actual data as well as realistic projections. A third is to assess the technology and to point out specific R&D areas that need to be addressed.

SECTION II

DESCRIPTION OF A SALT-GRADIENT SOLAR POND

A typical salt-gradient solar pond can be depicted by the schematic shown in Figure 1. Pond area can range from several hundred square meters (a fraction of an acre) to several square kilometers (hundreds of acres). Pond depth usually varies between three and five meters, depending on the location and intended application. A pond is formed by excavation or embankment, or a combination thereof. The sides and bottom of a pond may or may not be lined with a plastic membrane or other impermeable liner, depending on the underlying soil conditions and the extent to which the surrounding environment requires protection against possible salt contamination.

As reflected by the name, a salt-gradient solar pond is filled with brine made of one or several salts, with the salt concentration varying from a few percent (by weight) at the surface to over twenty percent at the bottom. A typical salinity profile is depicted in Figure 1. Normally, the surface zone (0.15-0.30 m) and the bottom storage zone (1.5-3.5 m) have uniform salinity, and the gradient zone (1-1.5 m) has a salt concentration that increases with depth.

As solar radiation impinges on the pond surface, part of it is reflected and the remainder penetrates into and is absorbed by the pond. To understand how a salt-gradient solar pond traps the absorbed solar energy, one may first examine why an ordinary pond (i.e. a fresh water pond or a saline pond with uniform salinity) fails to do so. In an ordinary pond, when the water absorbs the incident solar radiation, its temperature increases and its density decreases. The water near the surface is cooled as heat is dissipated to the atmosphere. The warmer, lighter water at the bottom will then rise to the surface causing a fluid circulation commonly referred to as natural convection. At the surface, the heat contained in the warmer water is again transferred to the ambient air. Thus an ordinary pond cannot store the solar energy that it absorbs.

In a salt-gradient pond, due to the presence of the constructed salinity gradient, natural convection is suppressed because while water at the lower layer may be warmer, it has a higher salt content and therefore remains heavier than water at the upper layer. In addition, the salt-gradient zone prohibits longwave reradiation (as water is opaque to infrared radiation), and offers an effective conduction barrier (because the thermal conductivity of water is relatively low and the gradient zone is sufficiently thick). Consequently, the salt-gradient zone enables the pond to trap heat in the storage zone, where the temperature is allowed to increase steadily to a level substantially above ambient. Typically, temperature in a salt-gradient pond increases with depth, varying from near ambient in the surface zone to 80°-100°C in the storage zone during the fall. Some representative temperature profiles are illustrated in Figure 1; note that they qualitatively resemble the salinity profile.

Both the surface and storage zone are convective (indicated in Figure 1 by the convecting currents). The convecting currents in the surface zone are caused by wind, evaporation, precipitation, diurnal heating and cooling, and other physical factors, in ways that have not yet been fully comprehended. The convecting currents in the storage zone, on the other hand, are induced by the

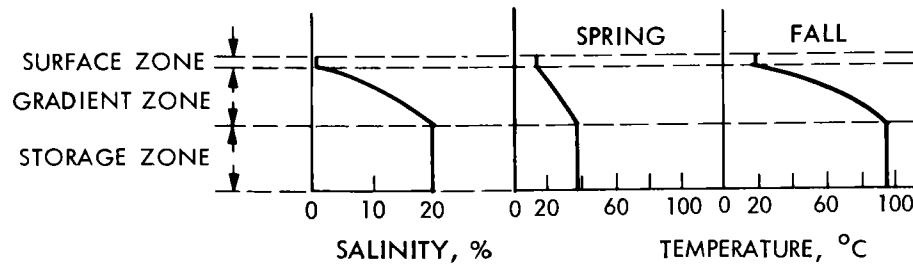
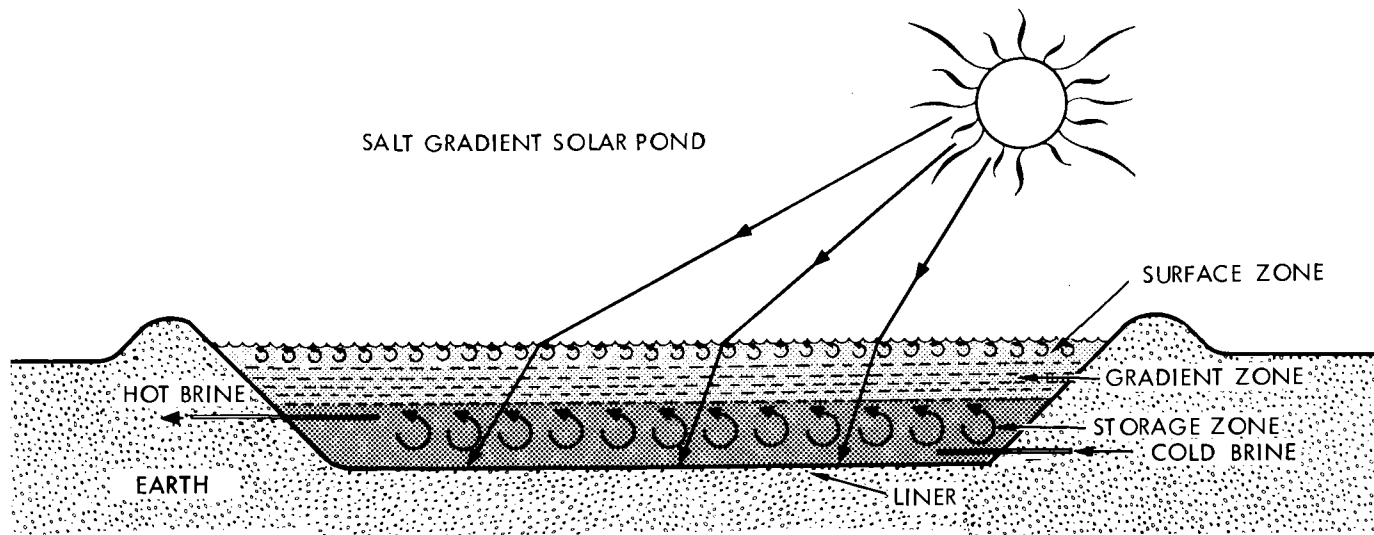

Figure 1. Schematic diagram of a Salt-Gradient Solar Pond with Typical Salinity and Temperature Profile

buoyancy of heated bottom brine, the disturbance from heat extraction, etc. The gradient zone is stratified and nonconvective. It separates the two convective zones above and below, and prevents a full-depth natural convection from occurring, thereby serving its vital insulating function.

Heat trapped in the storage zone can be extracted by means of in-pond or out-of-pond heat exchangers for both electric and thermal applications. Earlier experiences with in-pond heat exchangers have pointed out several disadvantages, such as corrosion and maintenance inconvenience. Particularly in large pond installations, out-of-pond heat exchangers are favored. Hot brine is withdrawn near the upper portion of the storage zone (Fig. 1) and circulated through an out-of-pond heat exchanger where a working fluid receives heat from the brine to perform its designed duties. The cold brine is then returned to the pond near the bottom of the storage zone, usually on the opposite end from hot-brine withdrawal. Thermal energy thus extracted from the pond can be used to generate electricity or support a variety of thermal applications such as residential and commercial building space and water heating, industrial and agricultural process heating, and desalination.

SECTION III

THERMAL AND HYDRODYNAMIC BEHAVIOR OF EXISTING PONDS

Major existing solar ponds in the world include the following:

1. U.S.A.

- a. Farm Science Review (FSR) pond, Ohio State University; 200 m² x 2.5 m (built in 1975)
- b. University of New Mexico (UNM) pond, 175 m² x 2.5 m (built in 1975)
- c. Ohio State University (OSU) pond, 400 m² x 4.5 m (built in 1980)
- d. Ohio Agriculture Research and Development Center (OARDC) pond, Wooster, Ohio, 155 m² x 3.0 m (built in 1975)
- e. Miamisburg pond, Ohio, 2020 m² x 3.5 m (built in 1978)
- f. Living History Farms pond, Iowa, 76 m² x 3.6 m (built in 1978)
- g. Argonne pond, Illinois, 1082 m² x 4.3 m (built in 1980)
- h. Desert Research Institute pond (saturated pond), Nevada, 10 m² x 1.0 m (built in 1979)

2. Israel

- a. Dead Sea Potash Works, 1100 m² (built in 1975)
- b. Eilat, 1100 m² (built in 1977)
- c. Yavne, 1500 m² (built in 1977)
- d. Ein Bokek, 7500 m² x 2.5 m (built in 1978)

In addition to these, there are small research/demonstration ponds in other countries such as India, Chile, USSR, Australia, etc.

Besides those listed above, Israel had constructed three ponds in the early 1960's, but they are no longer in operation. The United States also had some small research ponds that are not included in the above list. Performance data from the U.S. ponds are generally published in the open literature or can be obtained through private communication. In contrast, performance data from the Israeli ponds are relatively inaccessible. Consequently, the following examination of pond behavior will draw largely on the U.S. experiences, and particularly on those acquired from the FSR, UNM, OARDC, and Miamisburg ponds.

A. TEMPERATURE PROFILES

The history of the storage-zone temperature of the University of New Mexico pond is shown in Figure 2 (Ref. 9 and 10). The temperature reached a high of approximately 70°C during the first year of operation and reached well over 90°C during the second year. Being a relatively small pond, winter heat loss is substantial, but the lowest temperature throughout the first three years consistently has been at about 30°C. Daily heat extraction from this pond started in October of 1977, and was terminated in August of 1979. The effect of no heat extraction is reflected in the high pond temperature during the subsequent winter (over 45°C). In April of 1980, it was decided that the storage zone temperature was to be allowed to rise to the boiling point (Ref. 10). Boiling did occur in July, 1980, as will be discussed later in Section III, C.

As can be seen from Figure 2, a consistent phase lag exists between insolation and ambient temperature, and between ambient and storage-zone temperatures. The lag between insolation and storage-zone temperature is about 1-2 months for the UNM pond. Owing to the large thermal mass and inertia of the pond fluid, the storage-zone temperature is not sensitive to short term variation in insolation or ambient temperature.

Figure 3 shows, in greater detail, the temperature response of the UNM pond storage zone and the adjacent ground in 1978. It can be seen that during most of the year, the storage-zone temperature is higher than the ground temperature, resulting in the loss of heat to the adjacent ground. During the winter months, however, ground temperature is higher than the storage-zone temperature, and therefore heat flows back to the pond from the surrounding earth. This illustrates that the earth surrounding the pond actually is part of the thermal storage system and has a moderating effect on the pond temperature. An interesting aspect of Figure 3 is the sharp drop (approximately 15°C) of the storage-zone temperature that occurred in July 1978. This was caused by the breakdown of the gradient zone into a succession of small convective layers. The convective sublayers gave rise to enhanced heat transfer which caused the pond to lose a substantial quantity of heat. The damage to the gradient zone was repaired by adding one ton of salt to the gradient and storage-zones, raising the storage-zone salinity from the previous 16% to 20% by weight (Ref. 9). The recovery of the pond from this incident did not take long, and subsequent pond behavior appeared unaffected by the interruption.

The temperature history for the storage zone of the Miamisburg pond is depicted in Figure 4 (Ref. 5). Although the pond surface was covered with ice for an extended portion of the first winter following its construction, the lowest pond temperature was maintained at close to 30°C. Pond temperature reached a high of approximately 65°C during the first summer, and energy extraction began then for heating a municipal swimming pool. A slight drop in temperature in August of 1979, as shown in Figure 4, reflects the effect of heat extraction. Pond temperature in the second winter returned to the approximately 30°C level.

Some temperature profiles for the Farm Science Review pond, the Miamisburg pond and the UNM pond during their initial operation periods are presented in Figure 5 (Ref. 6), Figure 6 (Ref. 11), and Figure 7 (Ref. 2), respectively. Comparing these figures, it is immediately clear that the New Mexico pond attained a much higher storage-zone temperature than the Ohio ponds because of the much higher insolation level. The three zone configuration is common to all three ponds, although details of the profiles are different. The UNM (Fig. 7) and Miamisburg (Fig. 6) ponds appear to have better mixed storage zones than the Farm Science Review pond (Fig. 5). Both the UNM pond and the Farm Science Review pond showed several convective sublayers within the gradient zone (Figures 7 and 5).

The gradient-zone thicknesses of the three ponds all showed seasonal variation, ranging from less than 1 m to over 1.5 m, with greater thickness for the colder months than warmer ones. The ground-temperatures below the three ponds behaved in an analogous manner in that (1) the ground temperatures followed the pond temperatures faithfully and (2) the ground temperature gradients are steeper in the warmer months than colder ones. All three ponds were filled with NaCl solutions of comparable concentration and lined with plastic membranes.

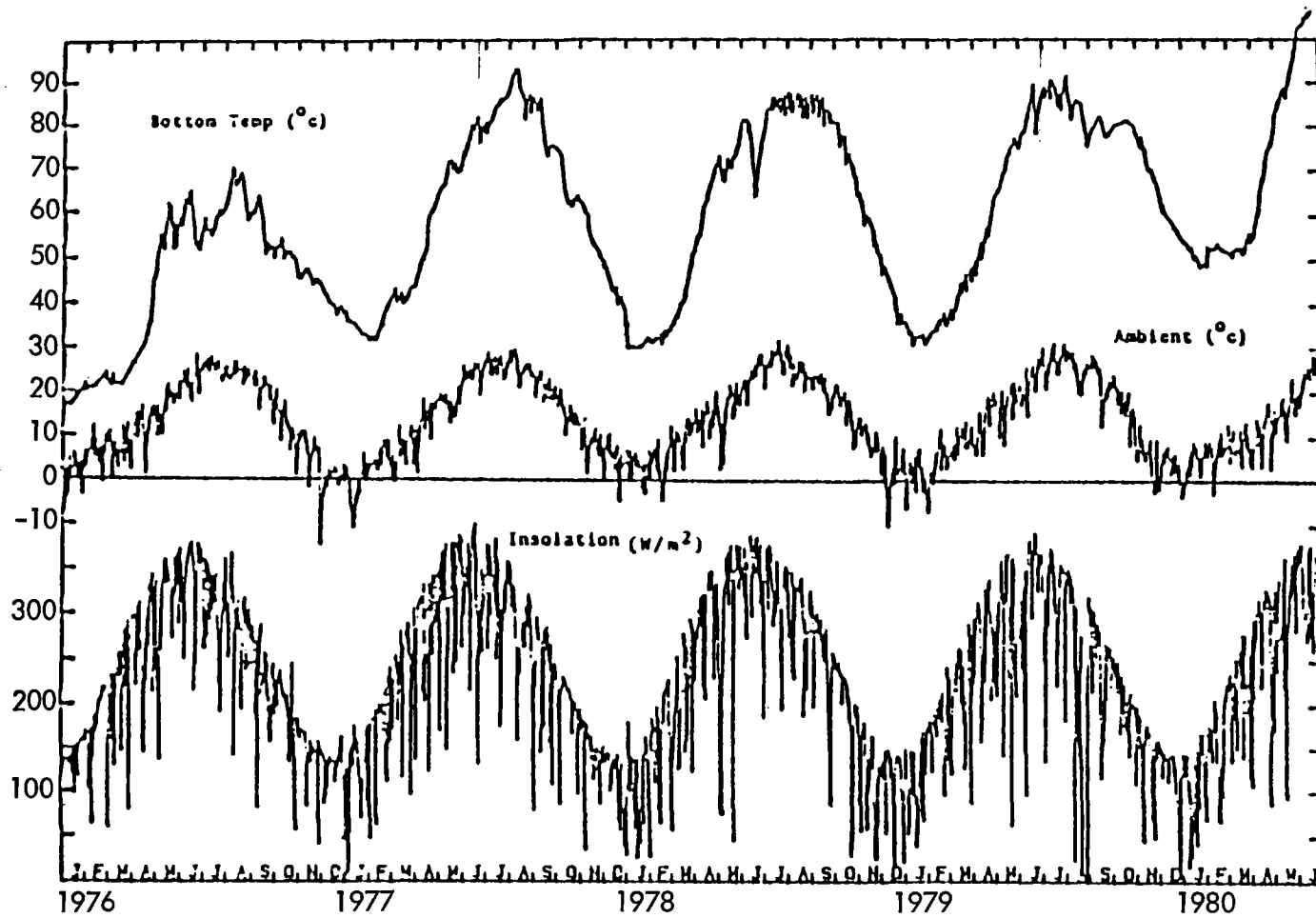

Figure 2. Thermal History of the UNM Solar Pond (Reference 10)

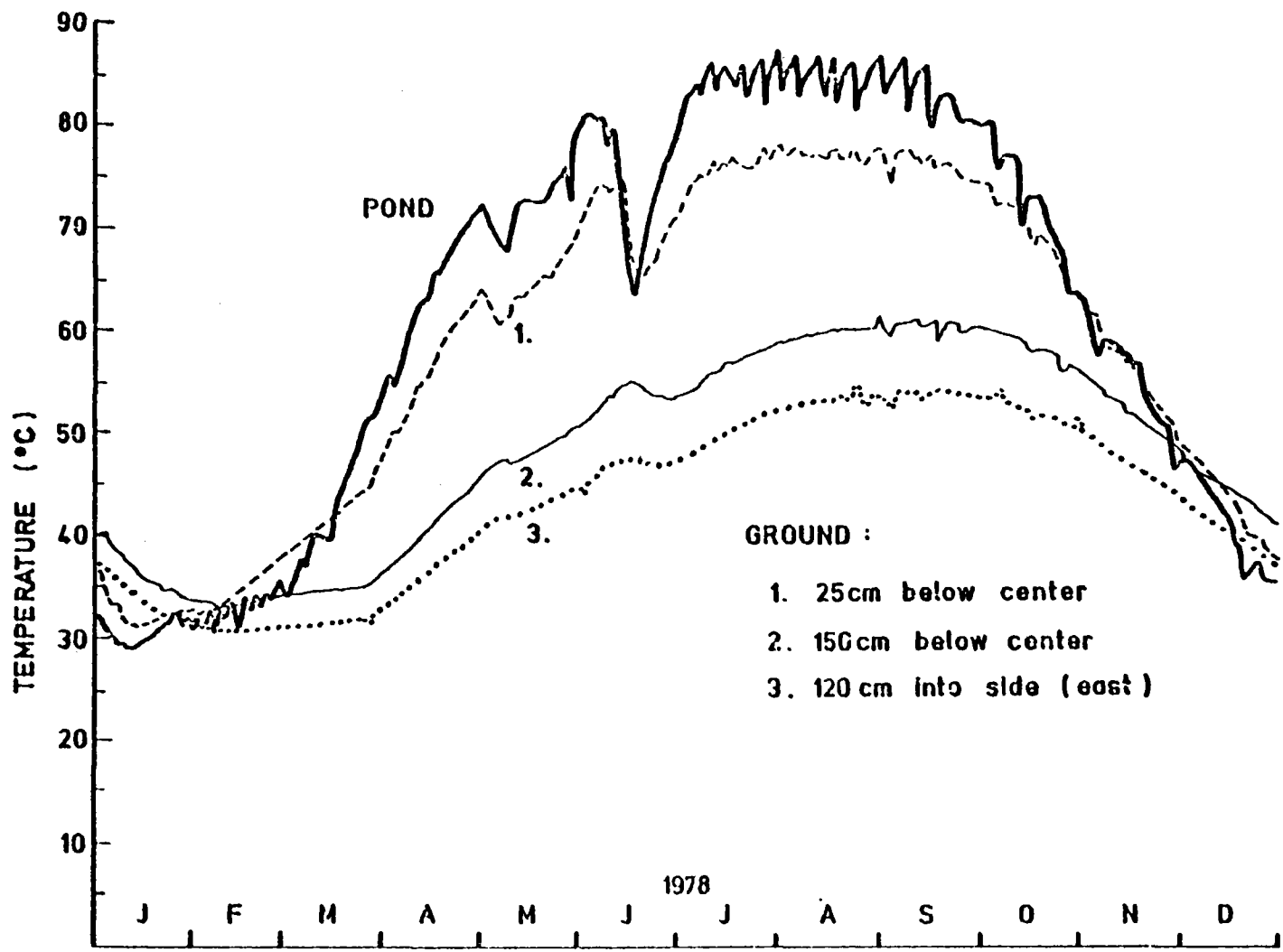

Figure 3. Thermal Response of the UNM Pond and Adjacent Ground in 1978 (Reference 9)

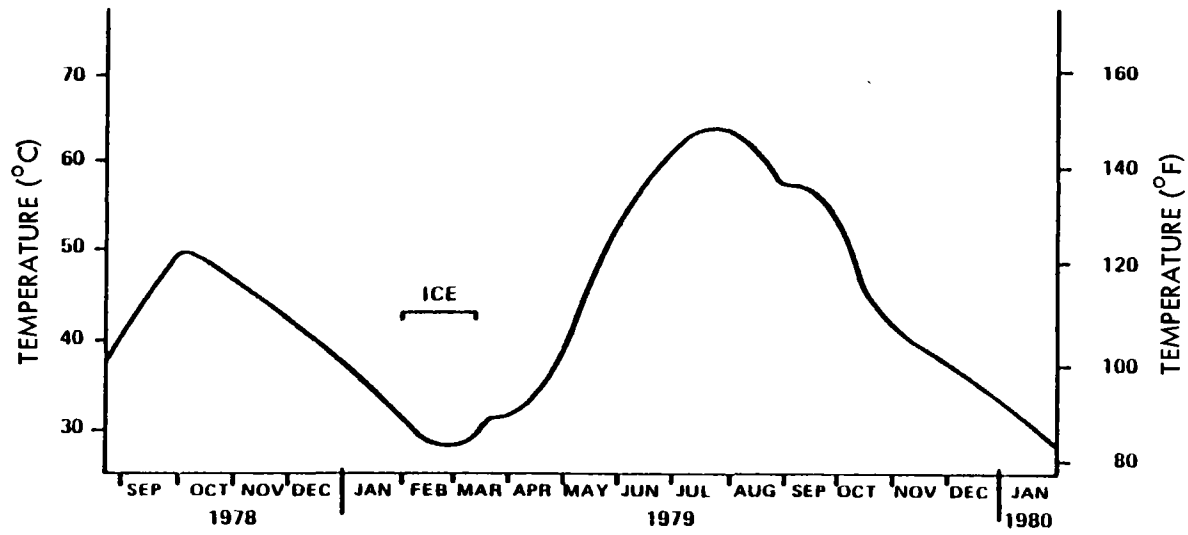

Figure 4. Storage-Zone Temperature History of the Miamisburg Pond (Reference 5)

A typical plot for the temperature, salinity, and density profiles for the OARDC pond is presented in Figure 8 (Ref. 12). Well-mixed surface and storage zones and a clearly-defined 1.2-m gradient zone are evident. This pond is also filled with a NaCl solution (17-18% by weight at the bottom) and lined with a plastic membrane (XR-5).

B. GRADIENT STABILITY

As noted previously, the working of salt-gradient solar ponds relies on the presence (via construction and maintenance) of the gradient zone. Upward salt and heat diffusion occur simultaneously and interact with each other within this zone. Hydrodynamic forces from the overlying and underlying convective zones also act on this zone. The gradient-zone boundaries migrate with time and as internal and boundary conditions vary. As a consequence, the thickness of the gradient zone changes, as observed in Section III, A. A specific plot for the time variation of the gradient-zone thickness of the Miamisburg pond (Ref. 11) is shown in Figure 9. As shown here, the thickness varies from under 1.0 m in the fall to over 1.6 m in the winter. A complete understanding of all the causes for the gradient zone behavior is lacking. But intuitively, it appears from Figure 9 that as pond storage-zone temperature decreases, so does the thermal driving force that operates in and tends to expand the lower convective zone.

Experiences from the existing ponds have indicated that, under normal operating conditions, gradient-zone stability does not present a problem. In fact, even when mild instability did occur (such as typified by the gradient zone breaking down to a succession of convective sublayers, as discussed in connection with Figure 3), it has been demonstrated that stability can be restored by a redistribution technique, which has been used by Nielsen (Ref. 6) and Zangrando (Ref. 9). Figure 10 illustrates the results of redistribution as observed in the UNM pond (Ref. 9). Figure 10a shows the effect of redistributing high-concentration brine taken directly from the storage zone. A diffuser was employed to inject the brine as it was moved from 45 cm to 75 cm below the pond surface at a constant rate of 1 cm/min. Mixing occurred in a region 15-20 cm below the moving diffuser and caused the internal steps to be smoothed out. Figure 10b shows the effect of redistributing low-concentration brine that was taken directly from the surface zone. The diffuser was in this case moved from the 50-cm level up to the surface zone at the rate of 1 cm/min. Injection of the low-concentration brine caused mixing in a region 15-20 cm above the upward moving diffuser, which led to the elimination of the undesirable convective sublayers. It was reported (Ref. 9) that if the convective sublayers are thin (less than 3 or 4 cm), they tend to disappear by themselves. However, thicker sublayers may grow, and corrective measures, such as the redistribution technique, must be employed to strengthen the gradient zone.

Stability of double-diffusive systems (e.g., solar ponds, in which heat and salt diffusion occur simultaneously) has been investigated by researchers in the fluid mechanics and oceanography areas, and many of their results are found relevant to the solar pond situations (Ref. 13). Stability criteria established through linear analysis by several authors (see references cited in Ref. 13) can be presented by a diagram shown in Figure 11, where stable and unstable regions are delineated in the Ra - Rs plane. Ra represents the thermal Rayleigh number which is proportional to the temperature gradient and measures the

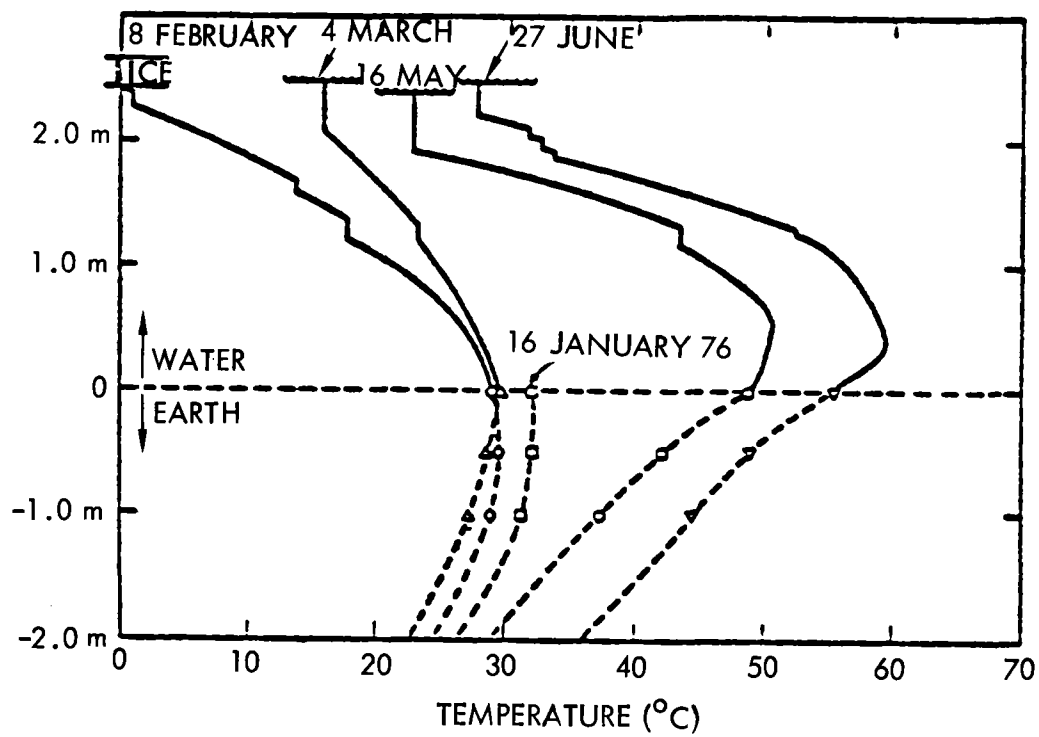

Figure 5. Temperature Profile for the Farm Science Review Pond (Reference 6)

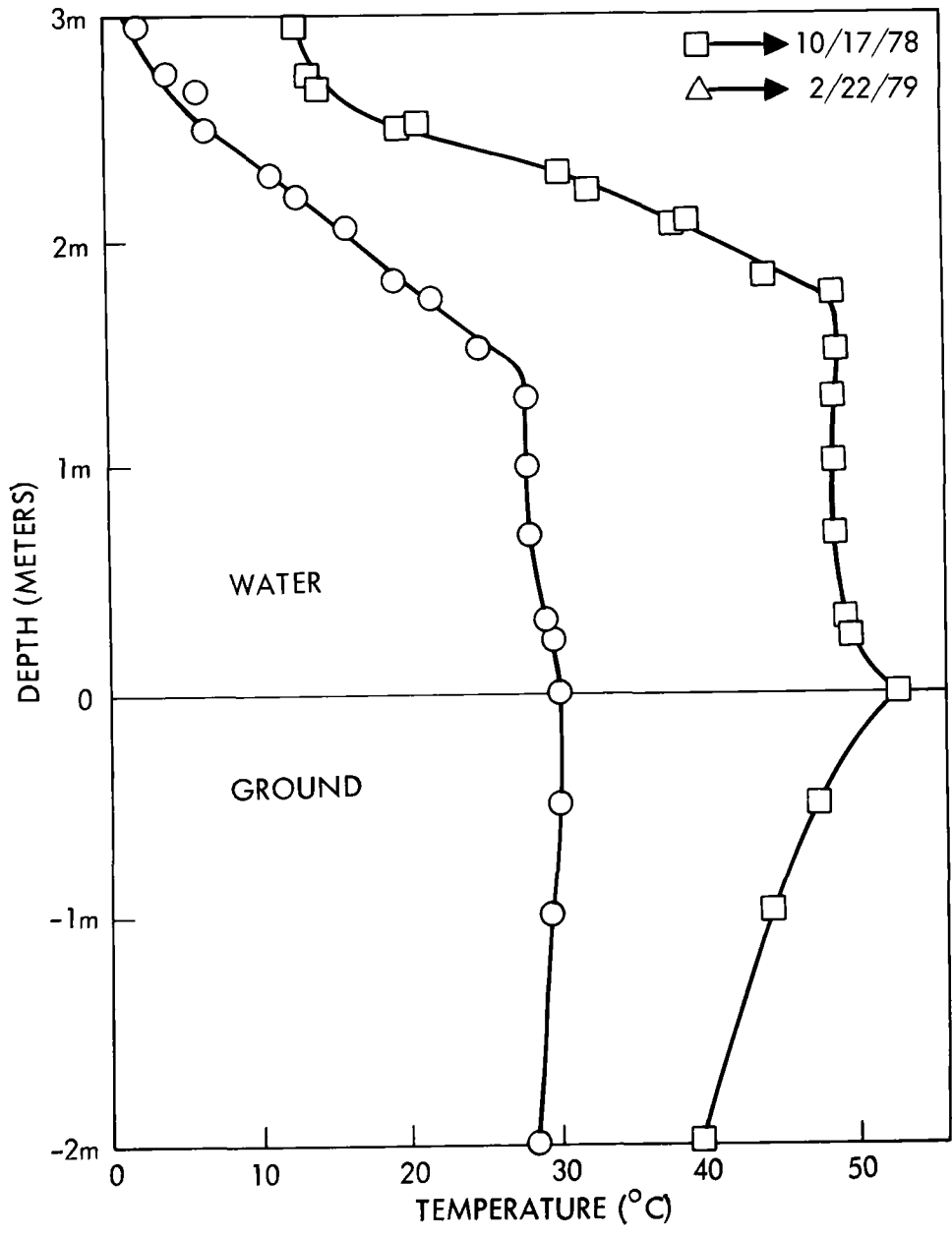

Figure 6. Temperature Profiles for the Miamisburg Pond (Reference 11)

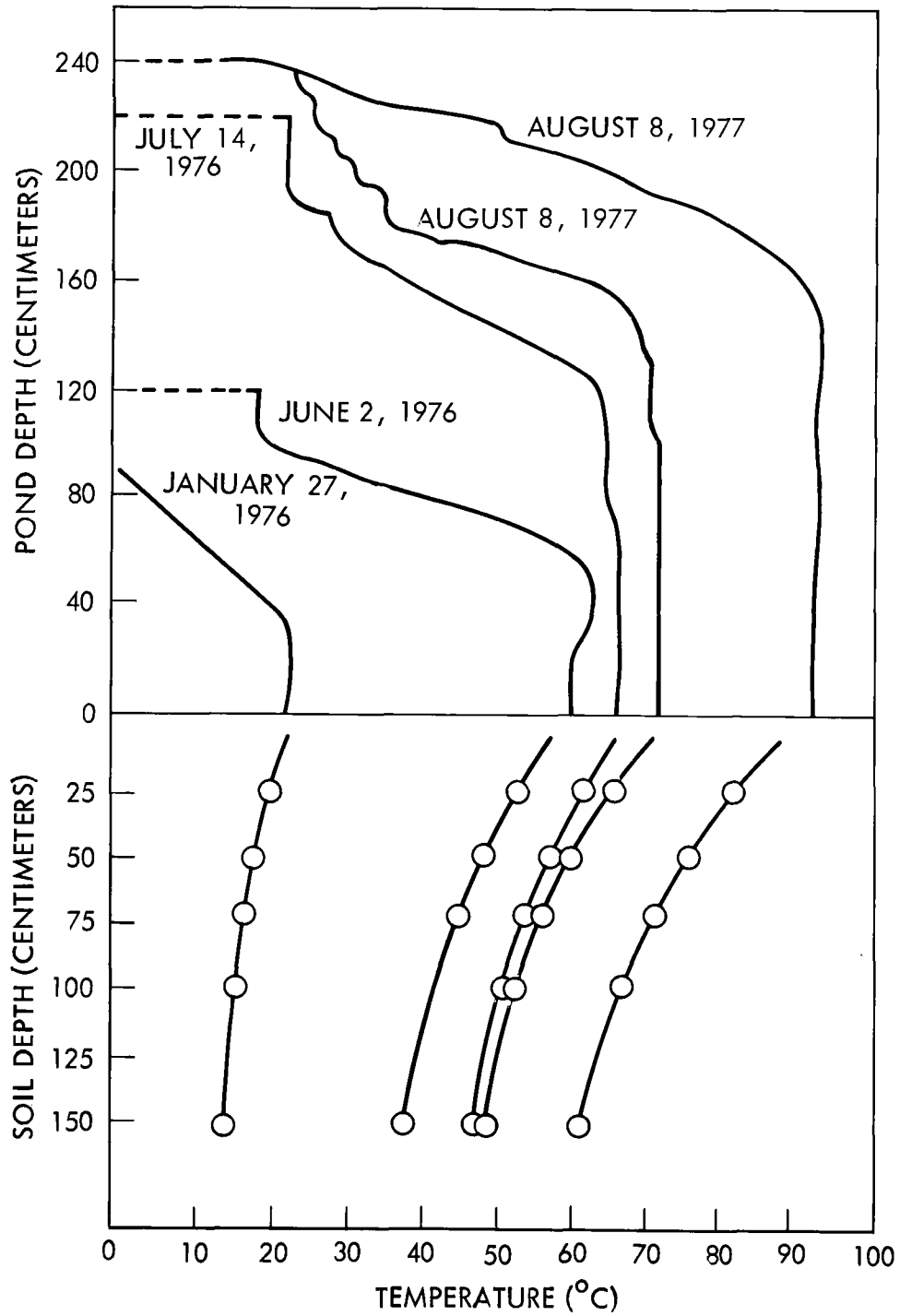

Figure 7. Temperature Profiles for the UNM Pond (Reference 2)

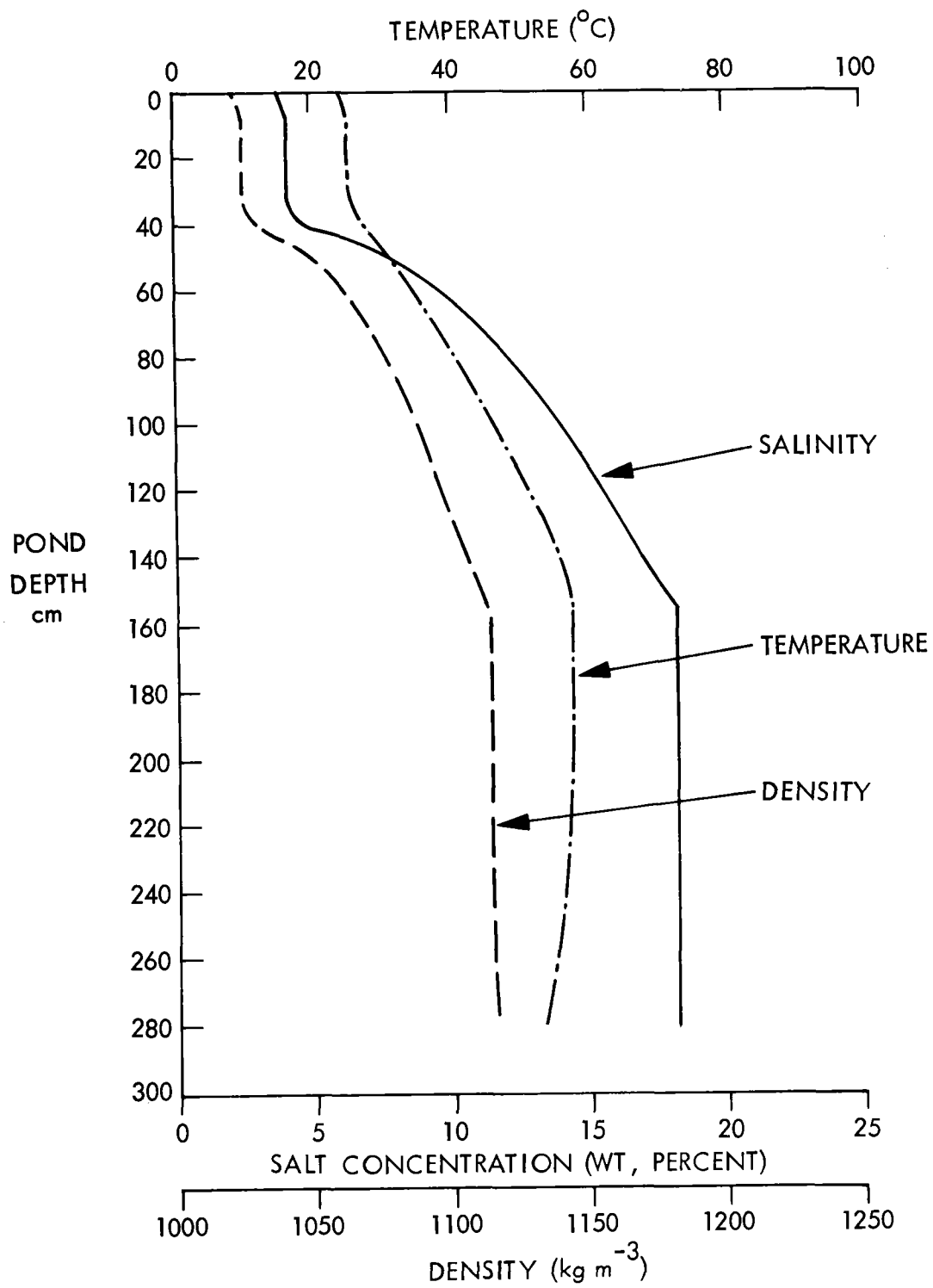

Figure 8. Temperature, Salinity and Density Profiles for the OARDC Pond (Reference 12)

magnitude of the destabilizing force in the system. R_s represents the salinity Rayleigh number which is proportional to the salinity gradient and measures the magnitude of the stabilizing force in the system. For operating solar ponds, both R_a and R_s are positive and large (on the order of 10^{10} to 10^{12}), and normal operating conditions can be described by points located within the shaded area of the first quadrant of Figure 11. The stability boundaries XZ and XW can be expressed by the following equations:

$$\text{XZ: } R_a = \frac{R_s}{\sigma} + \frac{27\pi^4}{4},$$

$$\text{XW: } R_a = \frac{Pr + \sigma}{Pr + 1} R_s + (1 + \sigma) \left(1 + \frac{\sigma}{Pr}\right) \frac{27\pi^4}{4},$$

where $\sigma = K_s/K_t$, and K_s and K_t designate salt diffusivity and thermal diffusivity, respectively. Pr stands for the Prandtl number which is a ratio of brine kinematic viscosity to thermal diffusivity.

Although, as indicated earlier, stability of the gradient zone has not presented any insurmountable problem to the existing ponds so far, attention must be paid to it when considering more extreme conditions that the pond may experience, e.g., very severe climate or enormous rate of heat extraction for peak power generation.

C. BOILING PHENOMENA

A study of boiling in a solar pond was conducted with the UNM pond in 1980 (Ref. 10). Left unattended, the pond experienced a steady temperature increase in the storage zone, as shown in Figure 12, until boiling occurred. The rate of temperature rise averaged $1.2^\circ\text{C}/\text{day}$ before 100°C was reached, and about $0.25^\circ\text{C}/\text{day}$ afterwards. Temperature profiles during the months preceding the boil are shown in Figure 13; these are normal profiles as one would expect. Boiling took place on June 23, 1980, at a predicted temperature of 106.5°C at 1.55 m below the pond surface. Eggs were suspended in the pond and cooked in five minutes. Subsequent to the boiling, instability in the gradient zone developed, manifested by rapidly enlarging convective sublayers. The pond temperature continued to increase for a few more days until July 5, 1980, when the highest temperature of 109°C was attained at 2.1 m below the pond surface. Irregularities are evident in the temperature profile (Fig. 14) recorded on that day. Ten days later, on July 15, 1980, the pond started losing substantial amounts of heat. Temperature profiles for July 15 and the subsequent days are depicted in Figure 15. A 20°C drop in the storage-zone temperature occurred in eight days.

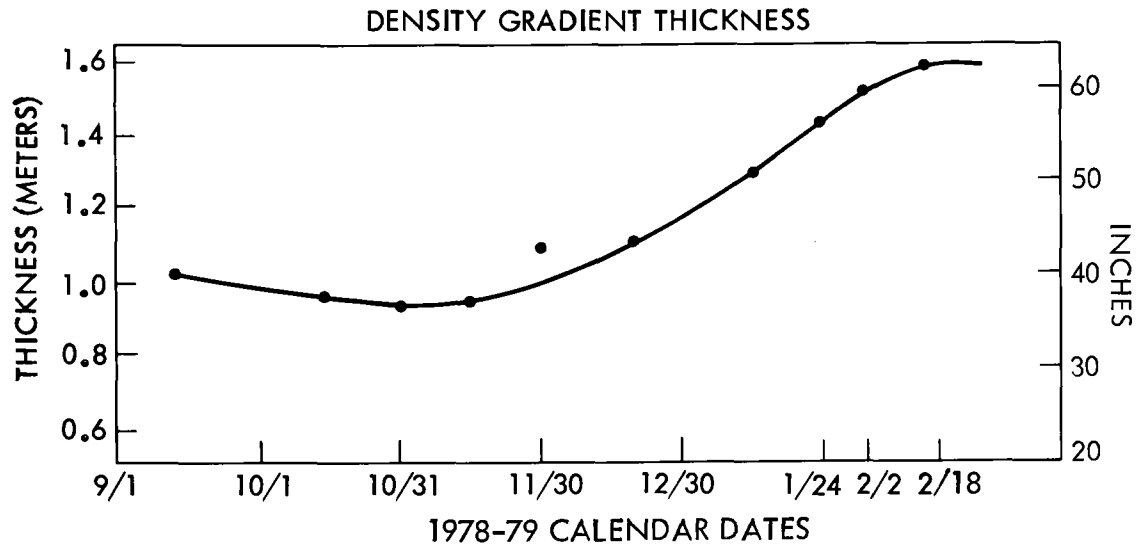

Figure 9. Gradient-Zone Thickness Variation With Time; Miamisburg Pond (Reference 11)

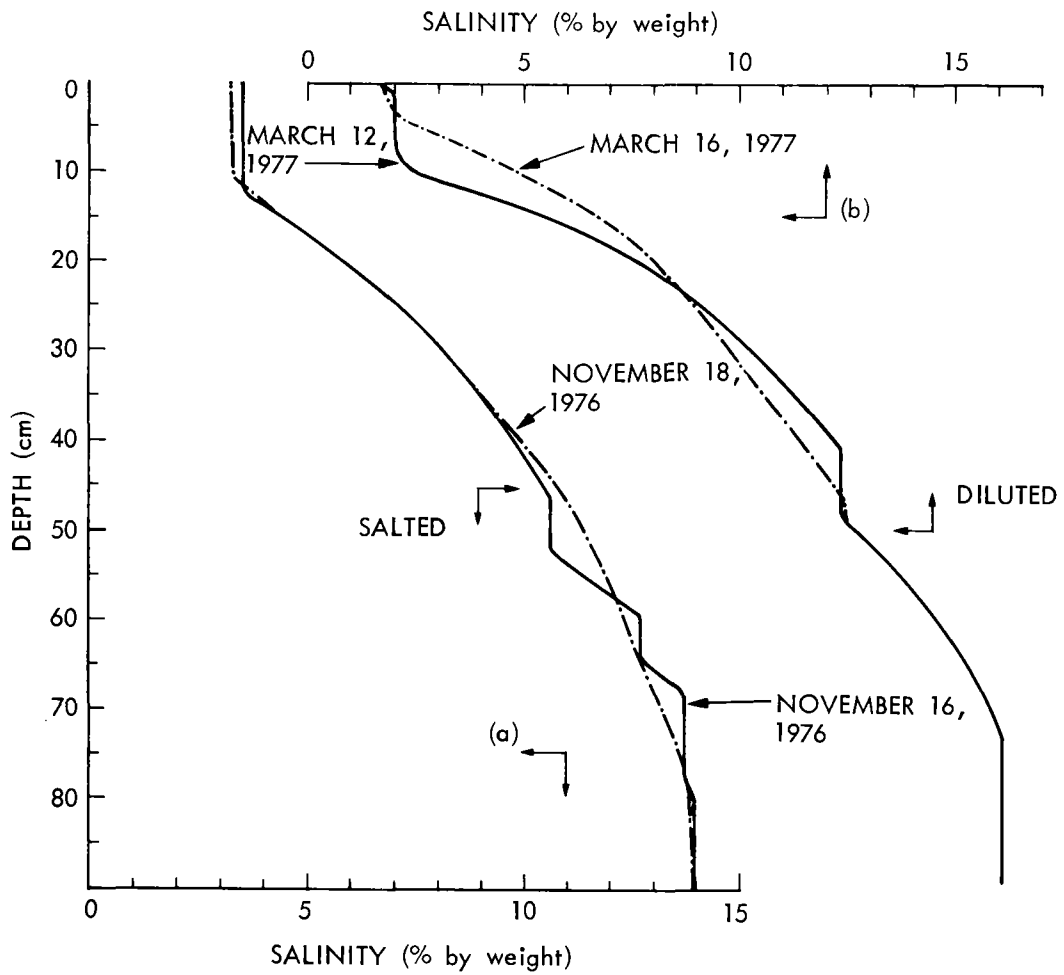

Figure 10. Redistribution Technique Used in the UNM Pond to Eliminate the Convective Sublayers in the Gradient Zone (Reference 9)

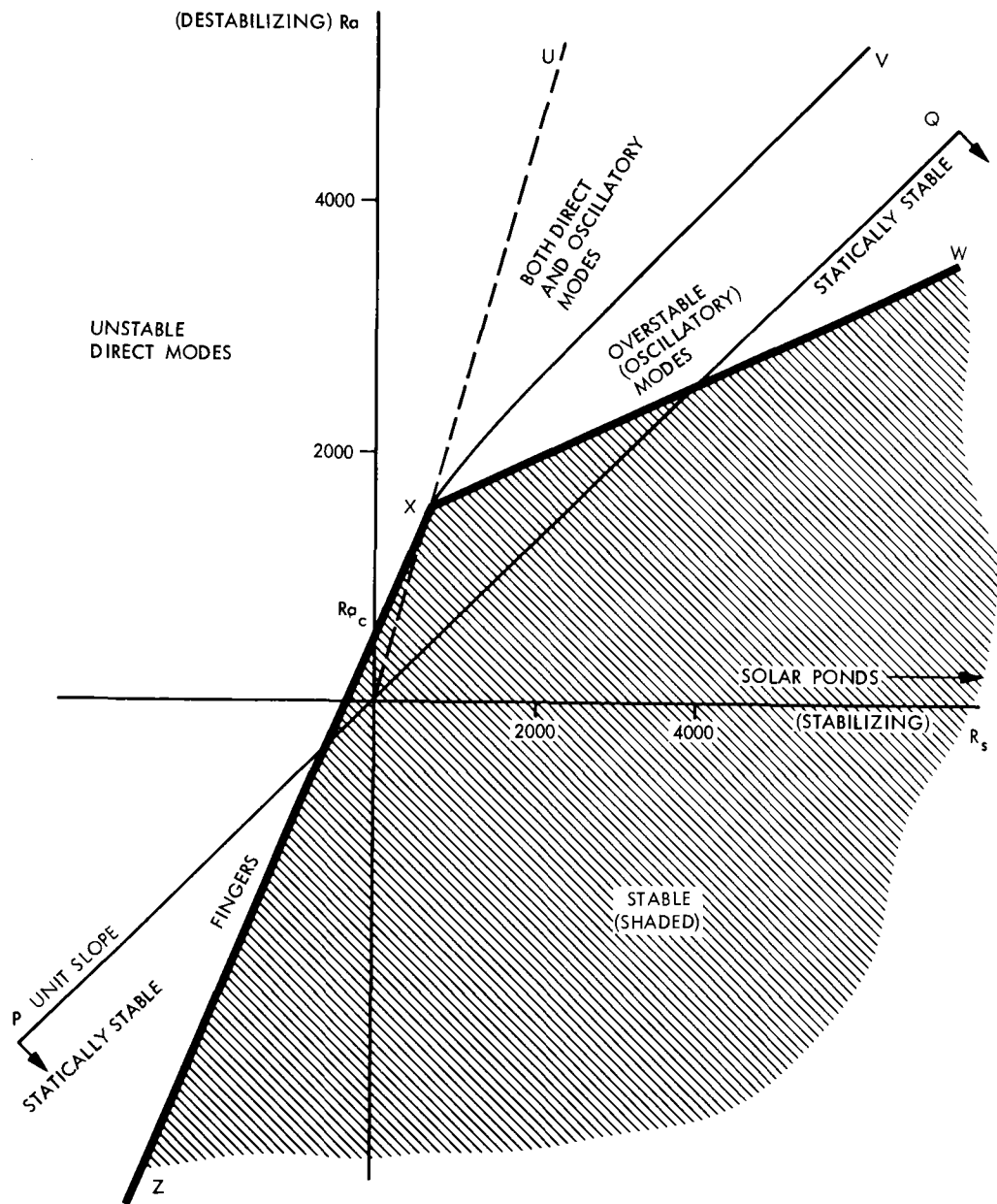

Figure 11. Stable and Unstable Regions for Double-Diffusive Systems.

This boiling study demonstrated that:

- (1) Pond boiling can occur during a period of intense insolation in a locale such as Albuquerque, New Mexico.
- (2) A temperature as high as 109°C is attainable.
- (3) Cooking with a solar pond is technically feasible.
- (4) Instability in the gradient zone will occur as a result of boiling.

The UNM pond also showed that boiling can be easily prevented by adequate heat extraction as was done during the years 1976-1979.

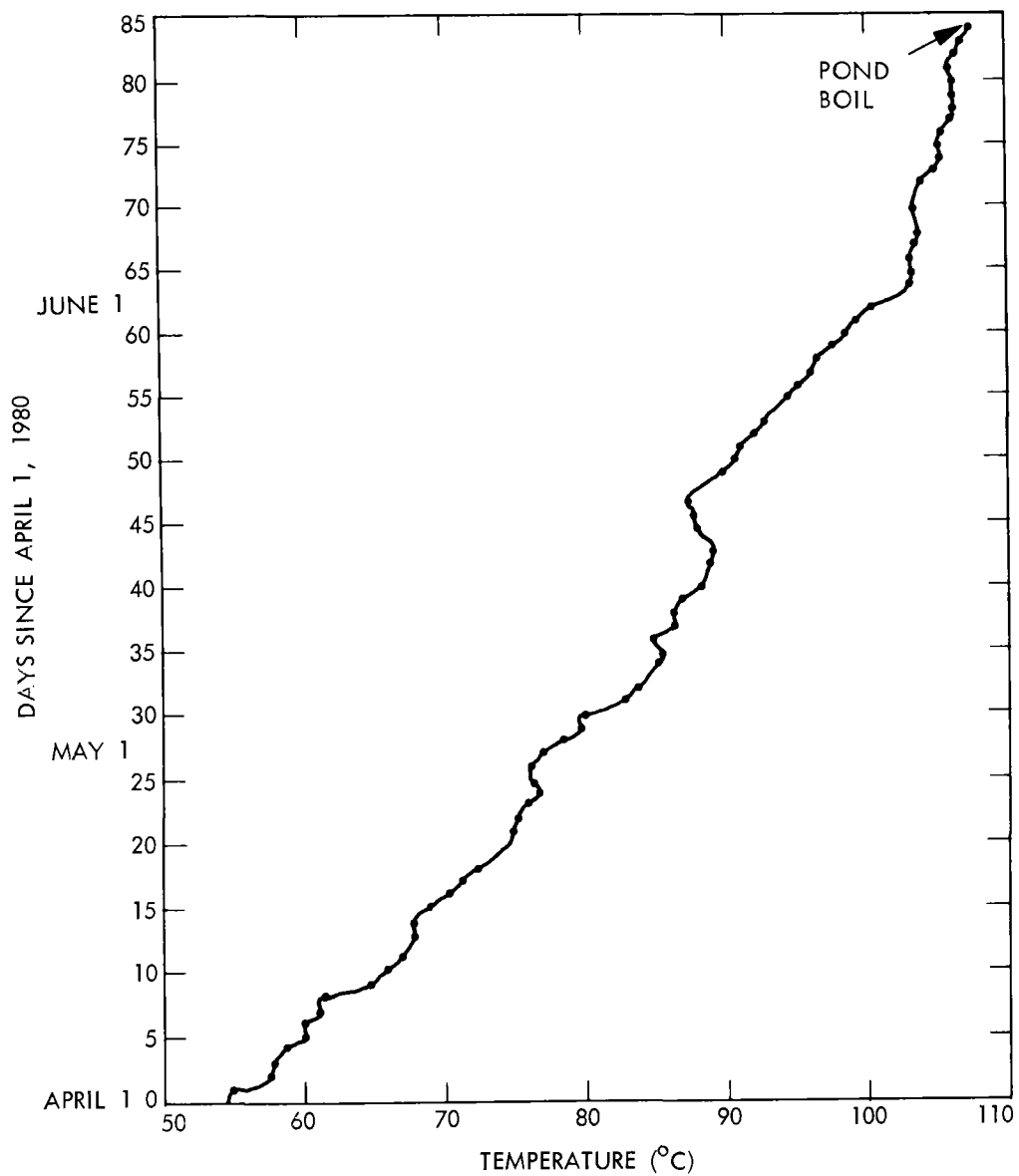

Figure 12. Steady Temperature Increase in the Storage Zone of the UNM Pond Prior to Boiling (Reference 10)

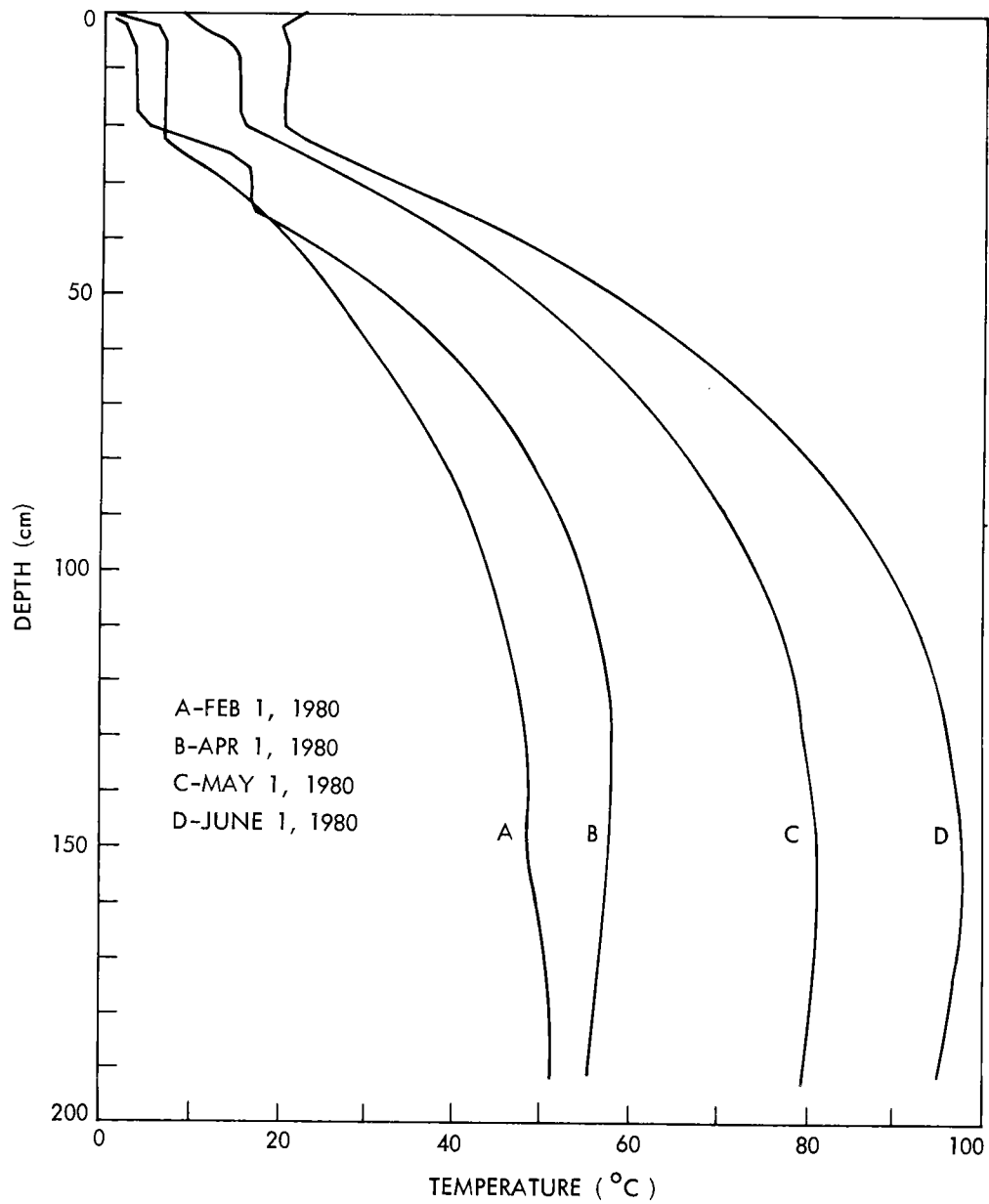

Figure 13. Temperature Profiles in the UNM Pond During the Months Preceding the Boil (Reference 10)

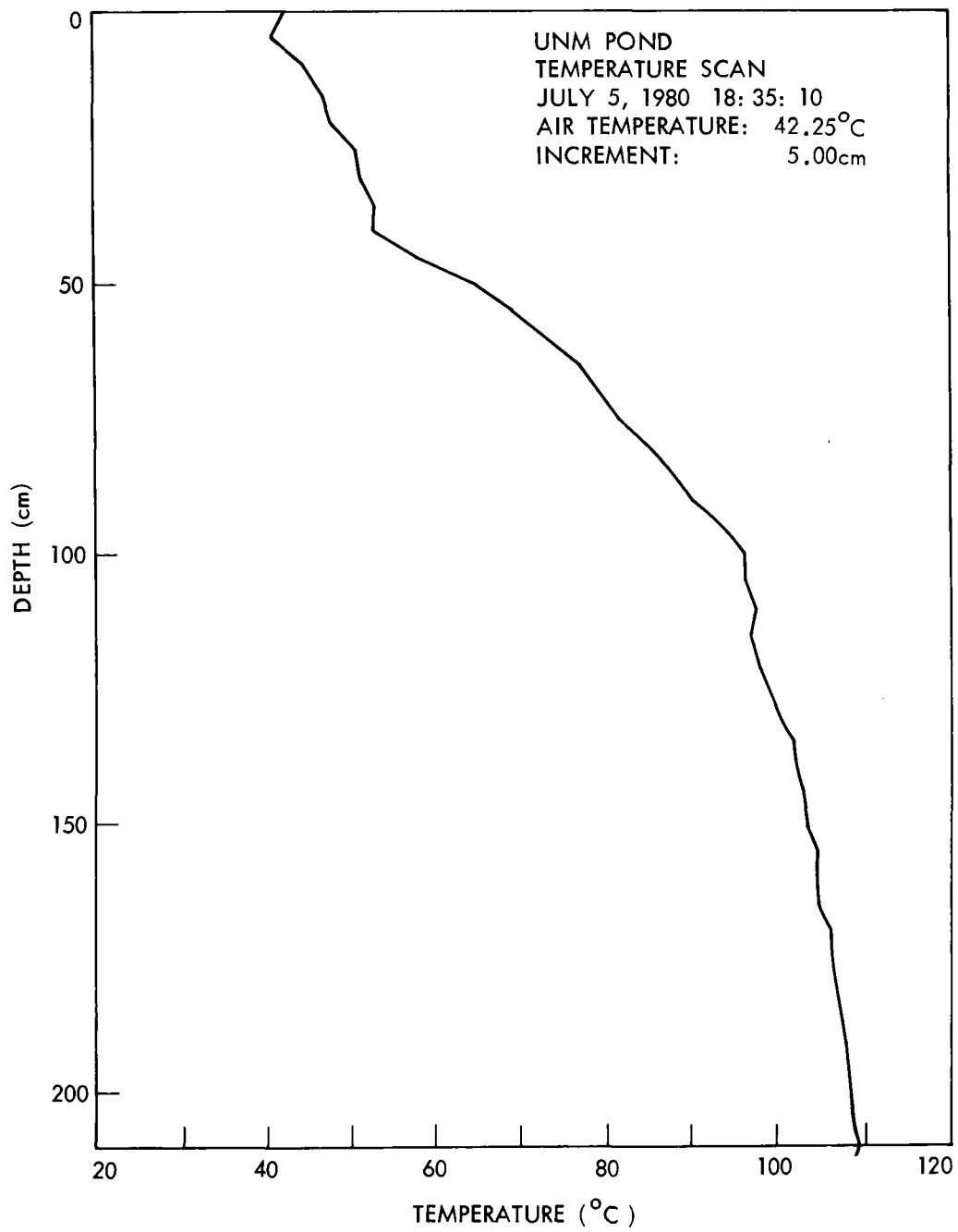

Figure 14. Temperature Profile in the UNM Pond When It Reached Its Highest Temperature (Reference 10)

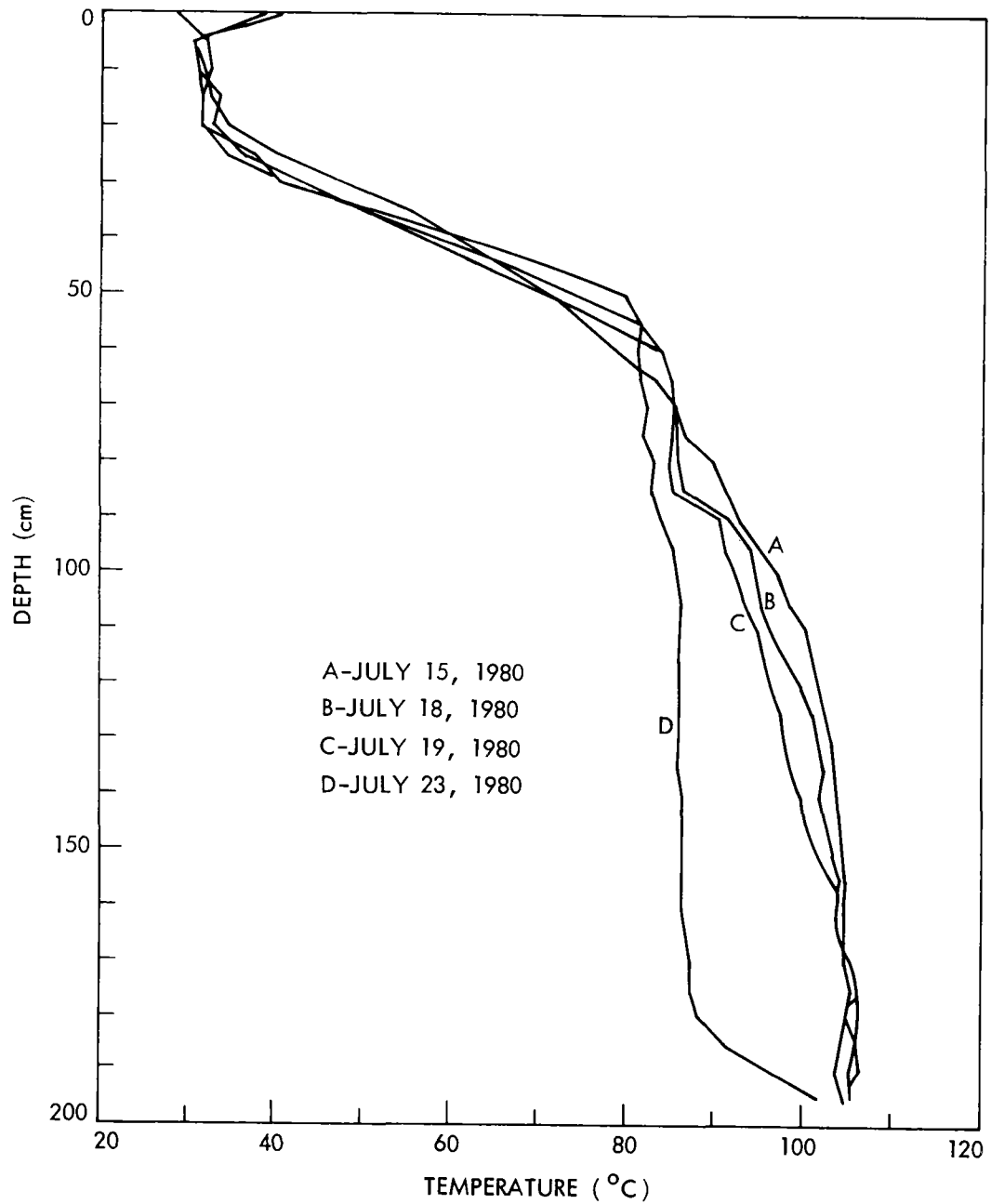

Figure 15. Temperature Profiles in the UNM Pond Following the Occurrence of a Large Instability in the Gradient Zone Caused by Pond Boiling (Reference 10)

SECTION IV

THERMAL AND ELECTRICAL ENERGY YIELD

Useful heat extracted from the storage zone of a solar pond generally represents only a fraction of the solar radiation incident on the pond surface. The ratio of the quantity of heat extracted to the total insolation is referred to as the pond's thermal efficiency. Thermal efficiency of a pond is a function of a number of variables. They include incidence angle of solar radiation, thicknesses and light transmissivity of the surface and gradient zones, and heat loss of various kinds. Heat loss from the storage zone to the atmosphere occurs first by conduction through the gradient and surface zones, and then by convection, evaporation and radiation at the surface. Thermal properties of the brine, and surface and ambient conditions are relevant to these heat transfer processes. Heat loss to the surrounding ground also occurs, and this depends on the pond size, and thermal properties and hydrological conditions of the ground. How, where, and when heat is extracted from the storage zone also affect the pond's thermal efficiency. These factors influence the thermal and hydrodynamic behavior of the pond and, hence, the energy balance of the pond with its environment.

With all the other variables fixed, the pond size alone generally affects the thermal efficiency in a monotonic manner; i.e., the larger the pond, the higher the thermal efficiency (as the ratio of side heat losses to stored energy decreases with increasing pond size). The existing ponds as discussed earlier are of relatively small sizes, and most of them were constructed and operated, not with maximizing energy output, but with various other R&D objectives in mind. Consequently, these ponds have not demonstrated the maximum thermal efficiency attainable. Nevertheless, their performance data provide a support to and a basis for estimation of pond energy yield.

Figure 16 presents an energy balance diagram for a 5-MW_e solar pond power plant at the Salton Sea. The calculations were made by Ormat Turbines, Ltd., based on their experience with the Israeli ponds (Ref. 14). A pond area of 1 km² (250 acres) and optical properties for Water Type #3 (continental shelf seawater) were assumed for the calculations. As can be seen in the figure, heat losses to the atmosphere amount to 84% of total insolation, heat losses to the ground amount to 2%, and thermal efficiency of the pond is 14%. Some energy output data from the existing ponds are presented in the following text, along with estimates/projections by several investigators.

A. THERMAL ENERGY

Heat extraction by direct withdrawal of hot brine from the UNM pond was performed during the period October 1977 - August 1979. In the twelve-month period of November 1977 - October 1978, in order to supply the simulated needs for space and water heating of a 185 m² house in Albuquerque, a total of 63×10^9 J was extracted from the pond (equivalent to an average energy output of 11.4 W/m²).

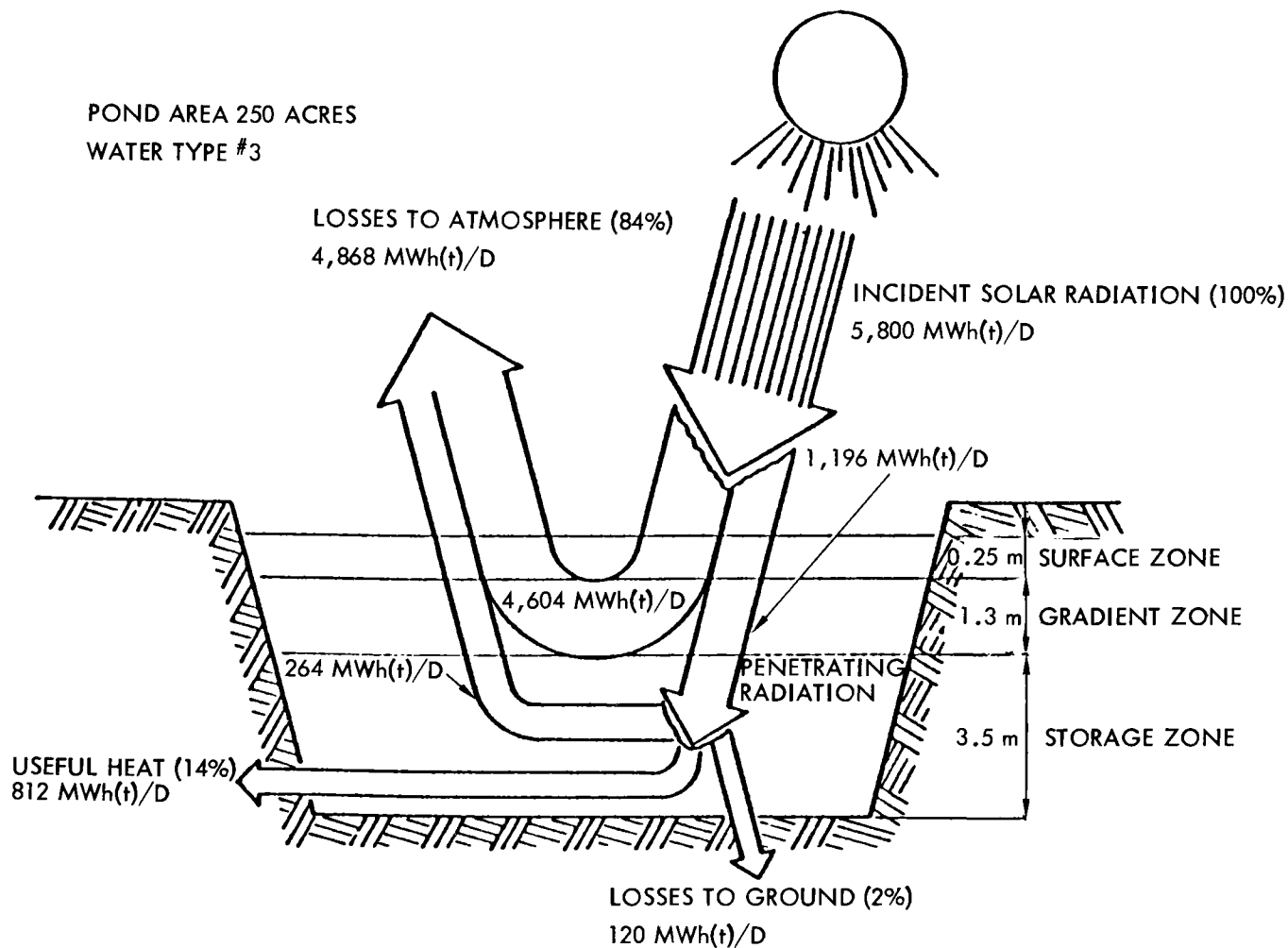

4-2

Figure 16. Energy Balance Estimated for the 5-MW Solar Pond Power Plant at the Salton Sea, California (Reference 14)

This represents only a fraction of the total stored energy. The pond's thermal efficiency for that period (with the surrounding ground warm-up still continuing) was calculated to be approximately 9% (Ref. 9). The steady-state thermal efficiency for the UNM pond was estimated to be 15% (Ref. 2).

At the Miamisburg pond, a total of 144×10^9 J (136×10^6 Btu) of thermal energy was extracted (via an in-pond heat exchanger) during June - September 1979 to heat a municipal swimming pool (Ref. 5). This amounts to less than 10% of the pond's available stored energy. The estimated thermal efficiency of the pond appears to be 10-15%, from data presented in Table 3 of Reference 5.

The OARDC pond was built to provide space heating to a greenhouse, with or without the assistance of a heat pump. Heat extraction was done by pumping hot brine out of the storage zone and circulating it through a shell-and-tube heat exchanger. Record of heat withdrawal during the period October 26 - December 8, 1979, shows that the pond provided 20.09×10^9 J of heat which satisfied 74.5% of the greenhouse's heating requirements (Ref. 7).

The Farm Science Review pond at Ohio State University utilized an in-pond heat exchanger to perform heat extraction experiments (Ref. 6). Heat extracted has had different applications, including grain drying, using a storage bin installed alongside the pond. However, no specific record of the amount of heat extraction is found in the literature for the FSR pond. The second OSU pond had been designed and constructed with energy-balance measurements in mind. Results from initial operation of this new pond were reported (Ref. 8), but energy yield data are not yet available.

Several computational tools are available for predicting thermal performance of a solar pond. An example of performance calculations is given in Figure 17. The calculation was made using JPL's thermal model to evaluate the feasibility of constructing a salt-gradient pond to provide space heating to a water treatment plant at Yankton, South Dakota (Ref. 15). A 6070-m^2 (1.5-acre) pond with a depth of 4.65 m (15.3 ft) was determined to be capable of meeting the entire annual heating load of the plant, estimated at 4300×10^9 J (4100×10^6 Btu). Computation was performed based on heat extraction matching the load profile and optical properties of charcoal-filtered Salton Sea water (which allows 26% of insolation to reach the storage zone), and other secondary assumptions. The computed thermal energy output and storage-zone temperature are shown in Figure 17 as a function of time. The steady-state thermal efficiency for this pond was calculated to be 13.4%.

B. ELECTRIC POWER

The principle of electric power generation with a solar pond by means of an organic Rankine cycle is illustrated in Figure 18. Hot brine is pumped out of the storage zone and circulated through an evaporator, where heat is transferred from the brine to the organic working fluid, thereby causing vaporization of the latter. The brine is then returned to the storage zone at a reduced temperature. Meanwhile, the vaporized organic fluid flows under high pressure to the turbine and, by expanding through the nozzles, drives the turbogenerator to produce electricity. The vapor then travels to a condenser where it is condensed to a liquid and pumped back to the evaporator. Condensation of the working fluid is

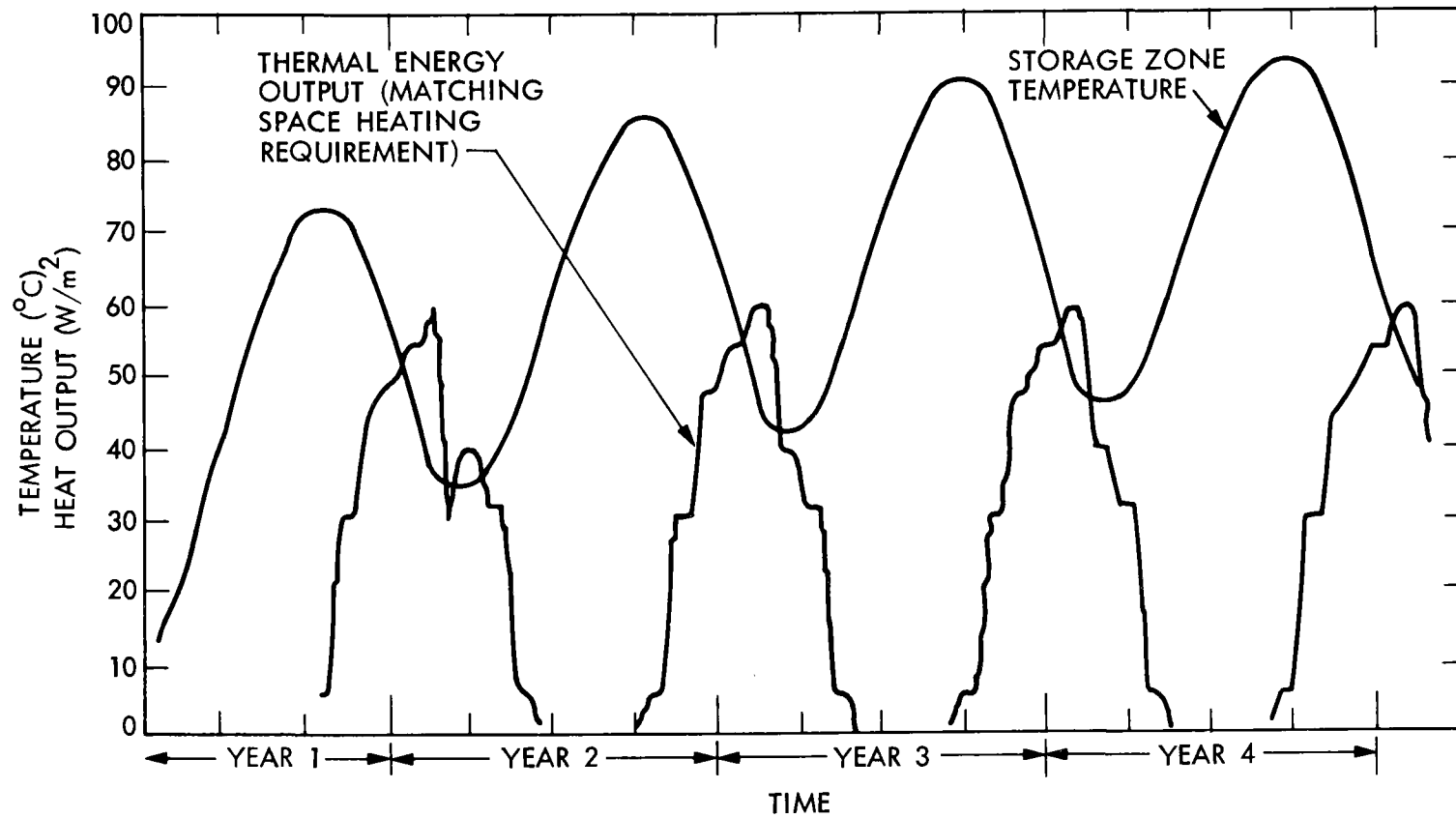

Figure 17. Computed Thermal Performance Characteristics for a 6070-m² Located in Yankton, South Dakota (Reference 15)

effected in the condenser with the circulating cold water from the surface zone of the pond. Thus the storage zone of the pond acts as the heat source while the surface zone acts as the heat sink, and the temperature difference between the two zones provides the basis for electric power generation.

Since the temperature difference between the heat source and sink is small, the Carnot efficiency of the power conversion cycle can reach only about 13%, and the gross power plant efficiency about 8.5%, according to Ormat experiences. The overall system efficiency for electric power generation from a solar pond, defined as the product of the pond thermal efficiency and the gross power plant efficiency, is expected to be between 1% and 2%. A set of performance data from the Ein Bokek pond in Israel (Ref. 3) is presented in Table 1. As can be seen from the table, although the average thermal efficiency of the Ein Bokek pond varies between 13% and 15% during its initial period of operation, higher thermal efficiency is possible as exemplified by the 19.4% efficiency figure recorded for the week of July 7 - July 13, 1980. As the pond behavior reaches steady state, higher thermal efficiency is expected. Note that for base load (continuous) operation, the 7500-m² pond has only a nominal 35- to 40-kW generating capacity, but a 150- to 170-kW peaking (intermittent) capacity was demonstrated. Oversizing the power conversion unit also enabled testing at a higher rate of heat extraction. Pond storage-zone temperature in excess of 90°C is common for the Ein Bokek pond.

The meteorological conditions at the Salton Sea are similar to those at the Ein Bokek pond. The 5-MW_e Salton Sea experimental solar pond power plant is at the preliminary design stage and is scheduled to start construction in late 1982 (Ref. 16). The plant will utilize a 1-km² (250-acre) solar pond with a depth of 5.0 m (16.5 ft), to be located on the northern boundary of the Salton Sea Naval Test Base. Projected energy yield for the 5-MW_e power plant is presented in Table 2, along with some assumed design conditions. A steady-state pond thermal efficiency of 17% and a gross organic Rankine-cycle power plant efficiency of 8.5% are stipulated. Accounting for a 20% parasitic power requirement, net electric power production is estimated at 24×10^6 kWh_e/km²-yr. The projected annual performance profile for the power plant is given in Figure 19 (Ref. 16). Both gross power and net power profiles fluctuate in accordance with the difference between the hot brine and cooling water temperatures, with peak output occurring in early December.

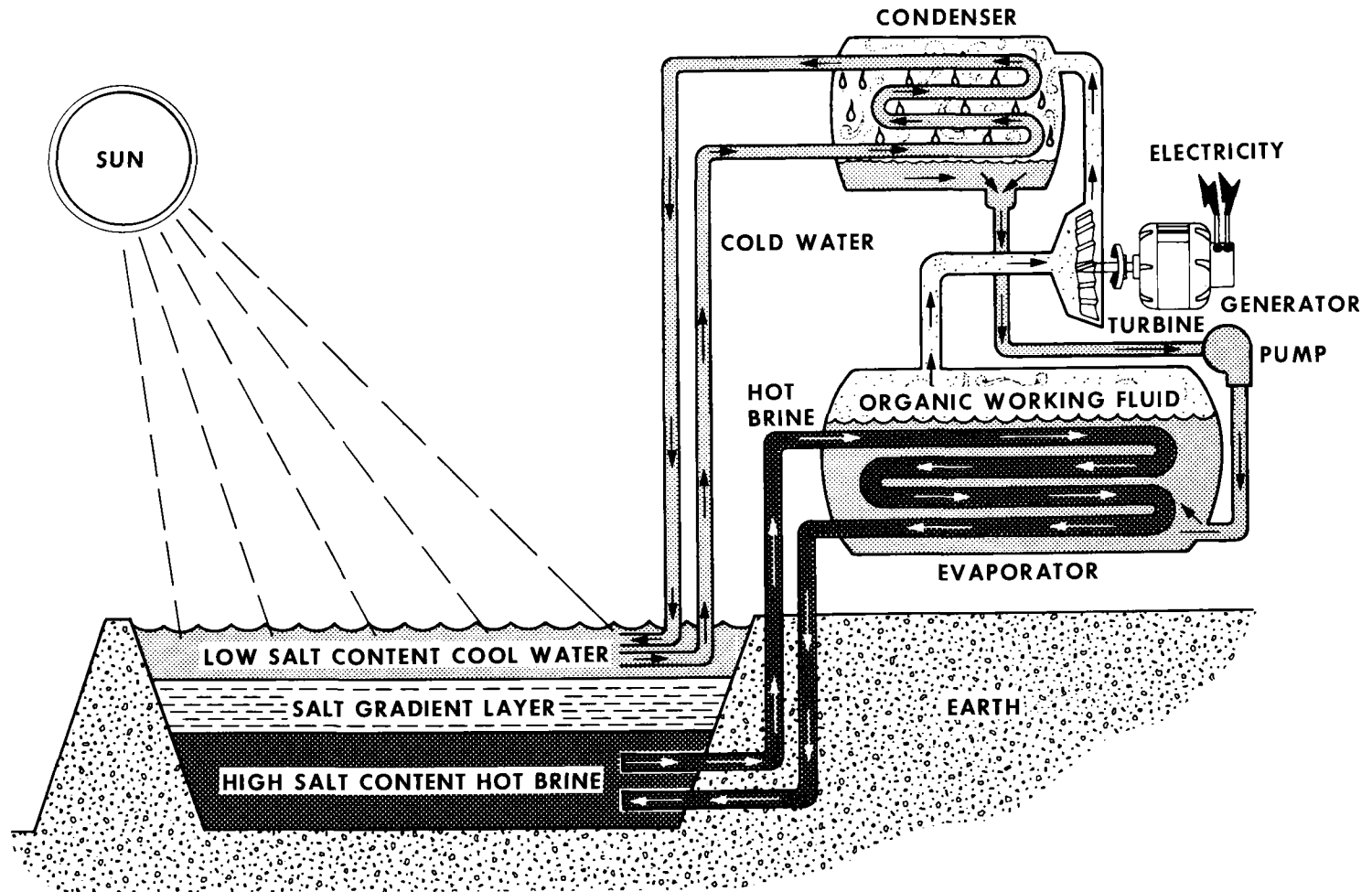

Figure 18. Electric Power Generation From a Solar Pond

Table 1. Performance Data From the 150-kW_e Pilot Solar Pond Power Plant at Ein Bokek, Israel (Reference 3)

Pond area (m ²).....	7,500	
Pond Depth (m)	2.6	
Storage-Zone Depth (m)	1.0	
Pond Thermal Efficiency (%)	13-15	
	<u>Summer</u>	<u>Winter</u>
Hot Brine Temperature (°C)	92	72
Cooling Water Temperature (°C).....	37	25
Hot Brine Flow Rate (m ³ /hr)	549	549
Cooling Water Flow Rate (m ³ /hr)	379	379
Working Fluid Boiling Temperature (°C)	86	66
Working Fluid Condensation Temperature (°C)	45	32
Electrical Gross Power (kW).....	170	150
Parasitic Power (kW)	33	28

Week: July 7, 1980 - July 13, 1980

Thermal Yield (kWh _t)	14263
Storage-Zone Temperature (°C)	93
Cooling Water Temperature (°C)	27
Pond Thermal Efficiency (%)	19.4

Table 2. Projected Energy yield for 5-MW_e Salton Sea Solar Pond Power Plant

Total Insolation (kWh _t /km ² -yr)	2120 x 10 ⁶
Annual Pond Thermal Efficiency (%)	17
Average Power Conversion Unit Efficiency (%)	8.5
Energy Yield :	
Thermal Energy (kWh _t /km ² -yr)	360 x 10 ⁶
Gross Electric Power (kWh _e /km ² -yr)	30 x 10 ⁶
Parasitic Power Requirement (%)	20
Net Electric Power (kWh _e /km ² -yr)	24 x 10 ⁶
Nominal Installed Base-Load Capacity (MW/km ²)	5
Assumed Design Conditions:	
Hot Brine Inlet Temperature (°C)	85
Cooling Water Inlet Temperature (°C)	23
Turbine Inlet Temperature (°C)	79
Turbine Exit Temperature (°C)	32
Carnot Efficiency (%)	13.3

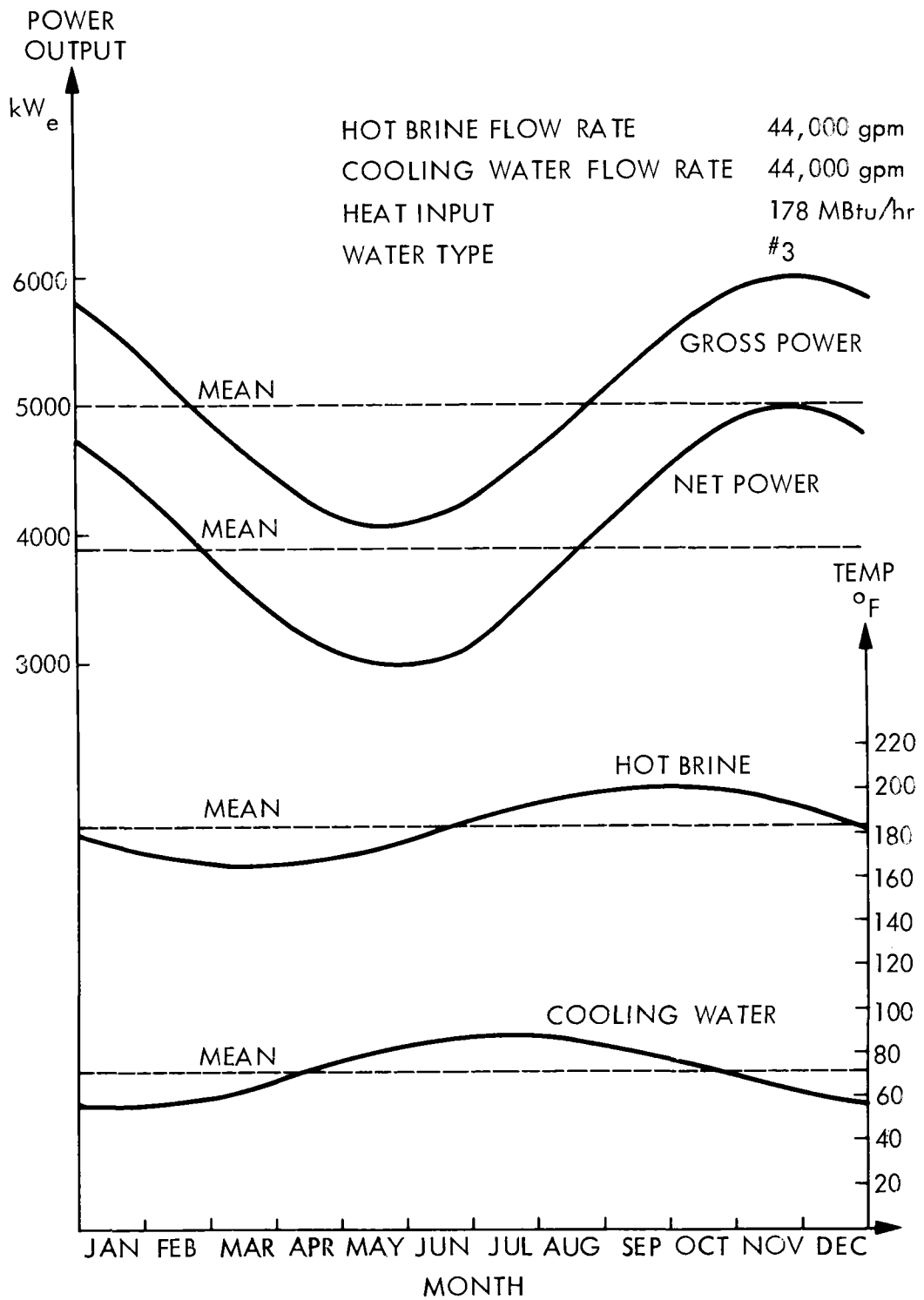

Figure 19. Projected Annual Performance Profile for the 5-MW_e Salton Sea Solar Pond Power Plant (Reference 16)

SECTION V

OPERATIONAL ASPECTS AND EXPERIENCES

Extensive operational experiences have been gained from the existing ponds. Particularly during the last seven years or so, pond researchers have encountered many practical problems or have had several concerns about certain operational aspects of solar ponds. Owing to their efforts, many of the problems or concerns have been resolved. Although the technical feasibility and merits of salt-gradient solar ponds appear to be well established at this stage, room for improvements exists in practically every area. For those who are not acquainted with the various operational details of solar ponds, the following summary of past experiences may be of some interest:

- (1) Wind Storm. Would a strong wind storm cause excessive mixing in the surface zone and lead to damage of the gradient zone so serious that a solar pond ceases to function? To date, none of the U.S. ponds have experienced any wind storm of severe proportion, but the Israeli ponds have been reported to withstand high winds and remain functional, free of any significant degradation of pond stratification. Specifically, the Ein Bokek pond has survived winds of greater than 90 km/hr, and the Yavne pond, gusts in excess of 120 km/hr (Ref. 3). The Israeli ponds have employed plastic netting which floats on the pond surface. Nielsen has also utilized a floating network made of 10-ft squares of 1-in. vinyl pipe to calm surface waves at the Farm Science Review pond (Ref. 6). The floating network acts as wave limiters and reflectors and effectively controls the growth and propagation of waves.
- (2) Rain/Hail Storms. Virtually all the existing ponds mentioned in this report have experienced rain storms, and some have experienced hail storms, but none has been reported to suffer damage from either. Nielsen reported (Ref. 6) heavy rainfall penetration of approximately 20 cm into the surface zone. On one occasion a severe rain storm in which 8.8 cm of rain fell in an hour appeared to have significantly modified the temperature and salinity profiles near the surface of the FSR pond, without causing any damage. In fact, on June 12, 1976, a rainstorm actually created a 15-cm gradient zone out of a very small experimental pond which was originally homogeneous with a uniform specific gravity of 1.086 (Ref. 6). Experience with excessively heavy hail storms has not been reported. However, it appears that rain is beneficial to the ponds as it helps dilute the surface brine and reduce the flushing requirement. Rain or hail storms of usual magnitude should not be considered a threat to the integrity of ponds.
- (3) Snow/Ice Coverage. The Ohio ponds have had periods of snow/ice coverage during the winter. The coverage bars transmission of solar radiation and reduces drastically the pond's solar intake. However, due to the tremendously large thermal storage capacity, the FSR pond and the Miamisburg pond did not drop below 30°C, even during the first year of operation (Fig. 4 and 5). Actually the snow/ice melts would have the desirable effect of diluting the surface brine. In fact, winter precipitation has naturally created a 0.25-m gradient zone for the second

OSU pond (400 m²) while it was still at a filling stage of construction (Ref. 8).

- (4) Fallen Leaves, Dust, and Debris. Heavy debris sinks to the bottom of ponds and does not adversely affect transmission of solar radiation. Lighter debris, as well as dust and leaves, may stay in the upper zones for a sufficiently long period of time as to obstruct penetration of solar energy into the storage zone. These must be removed from the pond. Surface flushing, combined with swimming pool-type cleaning techniques, has done a satisfactory job for all the existing U.S. ponds. For larger ponds, other devices besides surface flushing will be needed to achieve effective and convenient removal of the fallen objects. Nielsen has purposely let leaves stay in the FSR pond to investigate their effects and found that they would gradually sink to the bottom and discolor the brine, resulting in low solar transmissivity and hence reduced pond temperature.¹
- (5) Algae Growth. Poor transparency caused by algae growth has been experienced by all existing ponds. The addition of copper sulphate to the pond water has been found to be effective in halting algae growth and restoring the pond to normal transparency. In order for copper sulphate to remain in solution, the pond water must be kept within 5-6 pH range by, for example, addition of concentrated hydrochloric acid (Ref. 5). Tincture of iodine has also been found to prevent algae growth (Ref. 17).
- (6) Mud-Brine Reaction. In the existing lined ponds, mud-brine reaction has not been a problem. But such reaction in unlined ponds can potentially cause gas bubbling, which may disrupt the gradient zone, or sediment rising from pond bottoms, which may degrade transmissivity and, therefore, must be understood and controlled. This aspect of solar pond operation is site-specific and requires careful consideration.²
- (7) Turbidity and Coloration. Suspended particulates in ponds cause turbidity, and organic matter and trace ions such as Fe⁺⁺⁺ cause coloration. Both turbidity and coloration reduce transmittance of solar radiation into the storage zone. Studies performed with Salton Sea water have identified techniques to treat these problems which may be common, in varying degrees, to all solar ponds. Specifically, filtration and treatment with activated carbon have been shown to significantly improve transmittance in the wavelength regime that is important to solar pond operation (Ref. 18 and Fig. 20). The impact of brine transparency as influenced by these treatments is tremendous, as can be seen from Figure 21. A comparison between points (a) and (b) shows that carbon treatment alone can improve the percentage of insolation reaching the storage zone from 7% to 26%. This can be translated into a more than three-fold increase in electric power output (Ref. 18).

¹ Private communication with C. E. Nielson, August 1979.

² Private communication with H. E. Marsh, 1981

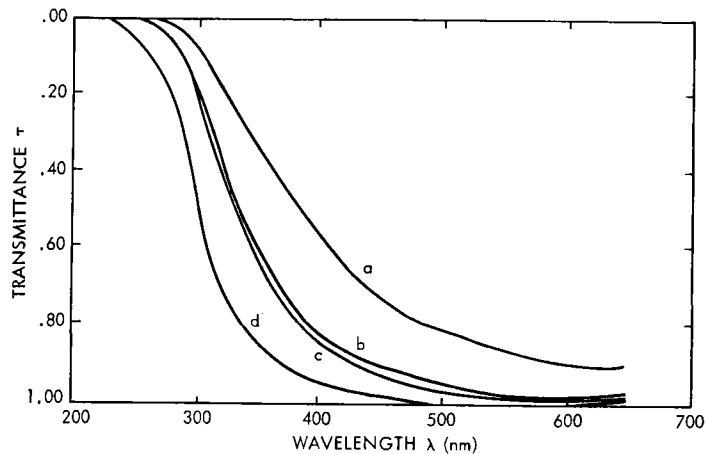

Figure 20. Solar Transmittance Gain With Treatment for Unconcentrated Salton Sea Water ($C = 0.038$, $\rho = 1020 \text{ kg/m}^3$), 50 mm path length. (a) Turbid; (b) Settled; (c) Settled, filtered ($0.45 \mu\text{m}$); (d) Settled, filtered, carbon-treated. (Reference 18).

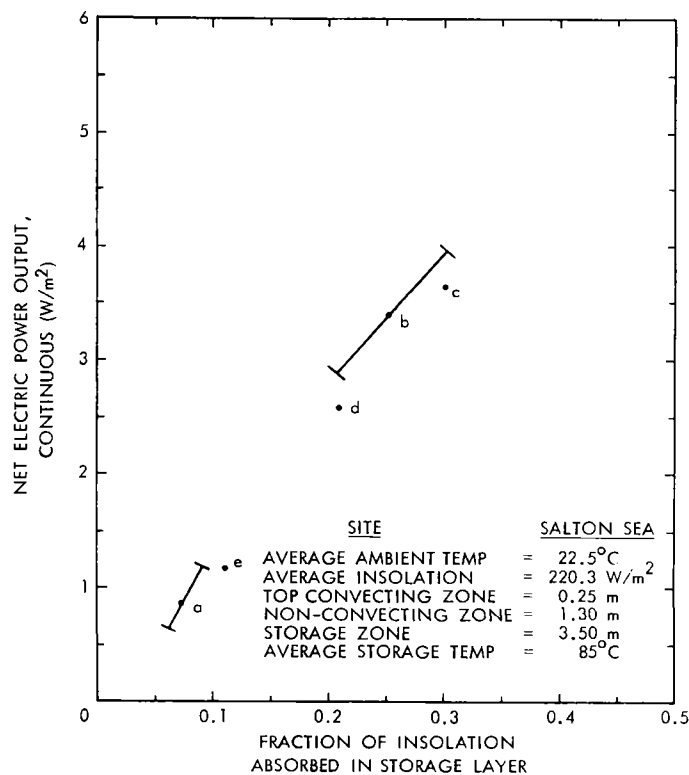

Figure 21. Calculated Solar Pond Electric Power Output Using Waters With a Variety of Spectral Absorption Characteristics. (a) Salton Sea brine, settled and filtered, transmittance varies with concentration; (b) Same as (a), carbon-treated; (c) Continental slope seawater, (d) Continental shelf seawater, unconcentrated; (e) Bay seawater, unconcentrated. (Reference 18).

- (8) Corrosion/Fouling. The in-pond heat exchanger at the Miamisburg pond has experienced severe corrosion in its original solder joints, composed of 95% tin and 5% antimony. The copper tubings themselves were virtually intact. Reconstruction of the heat-exchanger assembly made use of a 56% silver brazing alloy as soldering material, which then was found to be satisfactory (Ref. 5). The FSR pond also used an in-pond heat exchanger, but the hot, concentrated brine did not seem to affect its integrity. In fact, visual inspection of a recovered iron wrench which had fallen in and had remained in the bottom of the FSR pond for an extended period of time indicated that it was hardly corroded.¹ Out-of-pond heat exchangers are now favored both because of the lessons learned from the Miamisburg Pond and of the positive experiences other existing ponds have had with them (easy maintenance and little corrosion). Large-scale ponds, such as the Salton Sea installation, can contain complex brine constituents. Therefore, corrosion and fouling of the piping or heat exchangers in such ponds may require special attention. This site-specific issue is not considered insurmountable, however.
- (9) Liner Breakage. Virtually all existing ponds have been lined with plastic membranes of one kind or another (rubber, EPDM, chlorinated polyethylene, hypalon or XR-5) to guard against salt leakage. Liner breakage has occurred to the OARDC and the Miamisburg Ponds, both presumably due to inadequate foundation preparation. This caused local sagging and introduced tensile stresses in the liner, which lead to its eventual failure. In the case of the Miamisburg Pond, the liner broke at the seams in two places and was repaired by scuba divers without draining the pond. Recommended quality assurance measures dealt with liner fabrication and the preparation of a firm and smooth foundation on which the liner rests (Ref. 5).
- (10) Salt Contamination. Broken liners led to the loss of concentrated brine to the surrounding earth. In the case of the Miamisburg Pond this was a substantial quantity. Although no serious salt contamination problems were reported, such potential environmental hazards must be guarded against. Salt leakage probing devices when developed can be installed below and around the pond, and frequent salt inventory can be conducted. Once detected, timely repair of a broken liner can be made, minimizing risks of this nature.
- (11) Boiling. As discussed in Section III,C, the UNM Pond demonstrated that boiling can occur in a solar pond. Boiling will disrupt the gradient zone and result in great heat loss from the pond. However, boiling can be easily avoided by scheduled heat extraction.
- (12) Salt Diffusion. Salt diffuses from the high salinity regions upwards to the low salinity surface zone in a solar pond, usually at rates of the order of 10-25 kg/ m²-yr (Ref. 9, 19, and 20). This process tends to weaken the salinity gradient which must be maintained to ensure pond stability. A common procedure of reinjecting salt into the storage zone

¹ Private communication with C. E. Nielsen, August, 1979.

and flushing the pond surface with fresh or low-salinity water has been adopted by all existing ponds. Salt recovery by concentrating the surface washed-off water in an evaporation pond is also practiced.

- (13) Evaporation. Evaporation rate from open water surfaces varies from one location to another. The average annual evaporation ranges from 20 to 86 in. in the U.S. Water lost from a solar pond by evaporation is usually replenished by introducing fresh or low-salinity water to the pond surface, a routine maintenance work scheduled to match local requirements.
- (14) Earthquake. Damaging earthquakes have not been experienced by any of the existing ponds. In principle, an earthquake of sufficiently great intensity can break the pond embankment, tear the liner, or disrupt the gradient zone, just as it can destroy a building or a bridge. Quake-resistant provisions can be made in pond design just as they are in building or bridge design. Provisions also can be made to facilitate proper, timely repair of damages. One of the most serious hazards of an earthquake for ponds is salt leakage through impaired embankment to contaminate the environment. This must receive the same, serious consideration, in light of local conditions, as would the possible collapse of a city high-rise building during an earthquake.
- (15) Visual/Safety Hazard. If constructed in a populated area, a pond may be fenced in to prevent children or animals from falling in; a usual swimming pool treatment. Note that it is almost impossible to sink deep into the pond because of the brine's high density (scuba divers repairing the Miamisburg pond leaks had to carry lead weights in order to reach the bottom). A well-designed pond should not be an eye-sore and potentially can add to the landscaping esthetics, as suggested by the Miamisburg Pond.

SECTION VI

CONSTRUCTION AND COSTS

A. CONSTRUCTION

Small ponds, such as the existing research ponds, have been constructed with very basic equipment and techniques. Excavating and/or diking, preparing pond walls and bottom, installing the liner, filling the pond, and placing monitoring instruments have not presented unusual engineering challenges. Past experiences (Ref. 1,2,5,6,8,9) can provide adequate guides to future projects.

Site selection is important and factors to be considered include the availability of sunshine, land, water, and salts (the four essential ingredients), climate, soil conditions, ground water flow, intended applications, and economic, environmental and institutional aspects. Although it is preferable to construct ponds on sites where the ground water table is sufficiently far below the ground surface (as all U.S. existing ponds are), it is possible to build ponds on sites where the ground water table is relatively close to the surface. Two possible solutions to the situation are illustrated in Figure 22: (a) Combining above-ground diking with a certain amount of excavation, such that a reasonable distance is kept between the pond bottom and the ground water table; (b) Installing steel sheet piling around the pond to deflect the ground water flow path. Both these schemes prevent the flowing ground water from directly convecting heat away from the pond (Ref. 15).

The construction of large ponds, such as the Salton Sea Solar Pond (1 km²) is more involved, partly because of the large quantities of construction materials and concentrated brine required. Most likely, these must be locally available, and the construction techniques and procedures must be tailored to suit the local conditions.

In the case of the Salton Sea Pond, dikes will be erected to separate the solar pond from the sea. These earthfill dikes will utilize clay, sandy loam, gravel and dredged earth material from the pond site or its immediate vicinity. Schematics for conceptual earthfill dikes at the Salton Sea are shown in Figure 23. An impervious clay layer under the solar pond is essential for the containment of concentrated brine. Figure 24 presents a typical cross section showing the Salton Sea, the solar pond and the evaporation pond. Figure 25 shows a conceptual arrangement of the solar pond, evaporation pond, power and water treatment stations, diffuser assemblies, wind suppression netting, etc., for the 5-MW_e power plant. The production of high-salinity brine (25% by weight) from the low-salinity Salton Sea water (3.5% by weight) requires large acreage of evaporation ponds, substantial cost and a significant length of time. Approximately 2.43 km² (600 acres) of evaporation ponds are required to produce the required brine (4.2x10⁶ m³ or 3400 acre-feet) within five years. Enhanced evaporation techniques such as spray evaporation are being investigated to reduce the acreage and time requirements (Ref. 16).

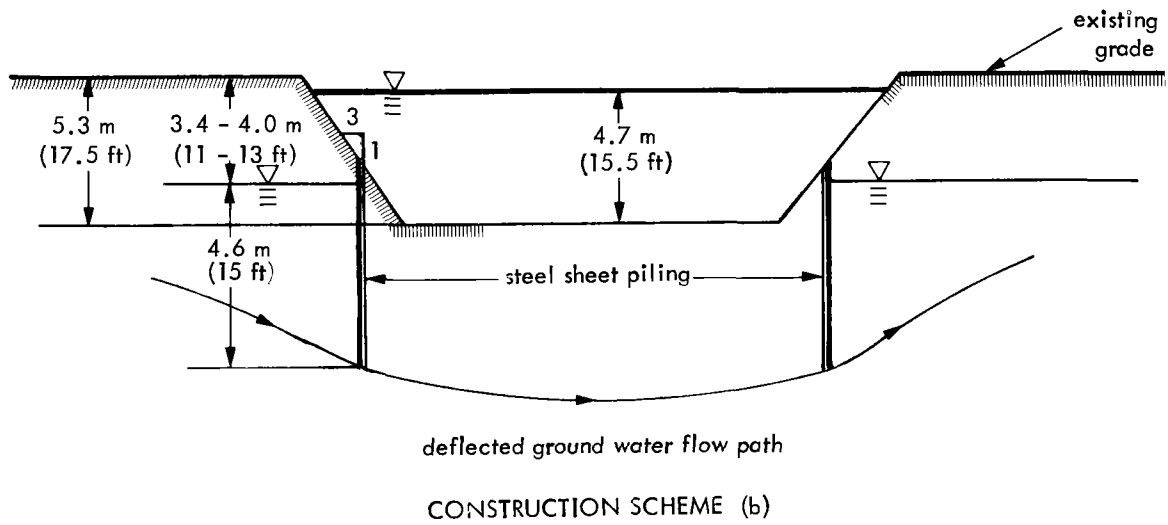
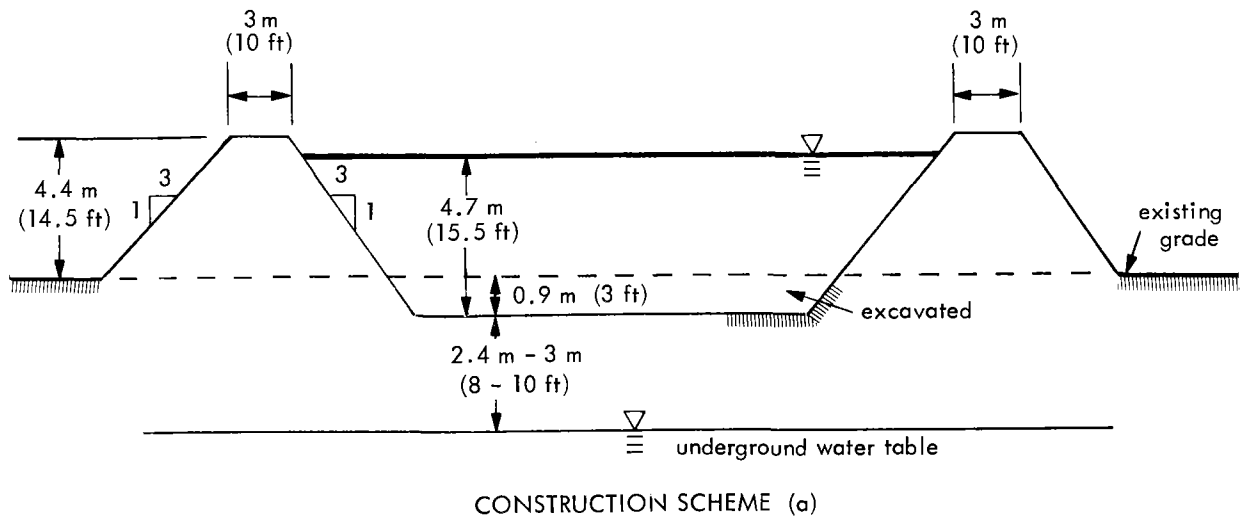

Figure 22. Construction Schemes on Sites with High Ground Water Table (Reference 15)

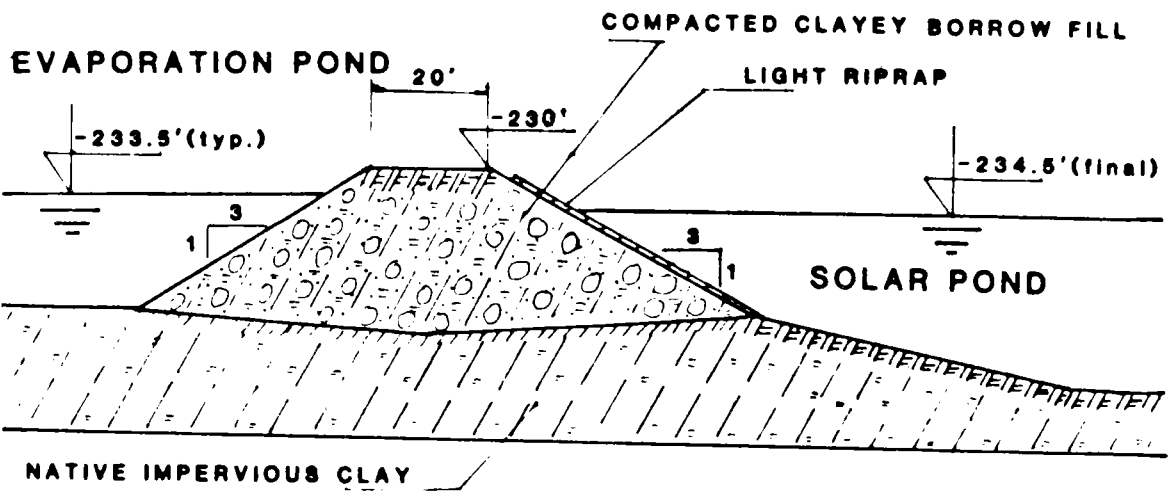
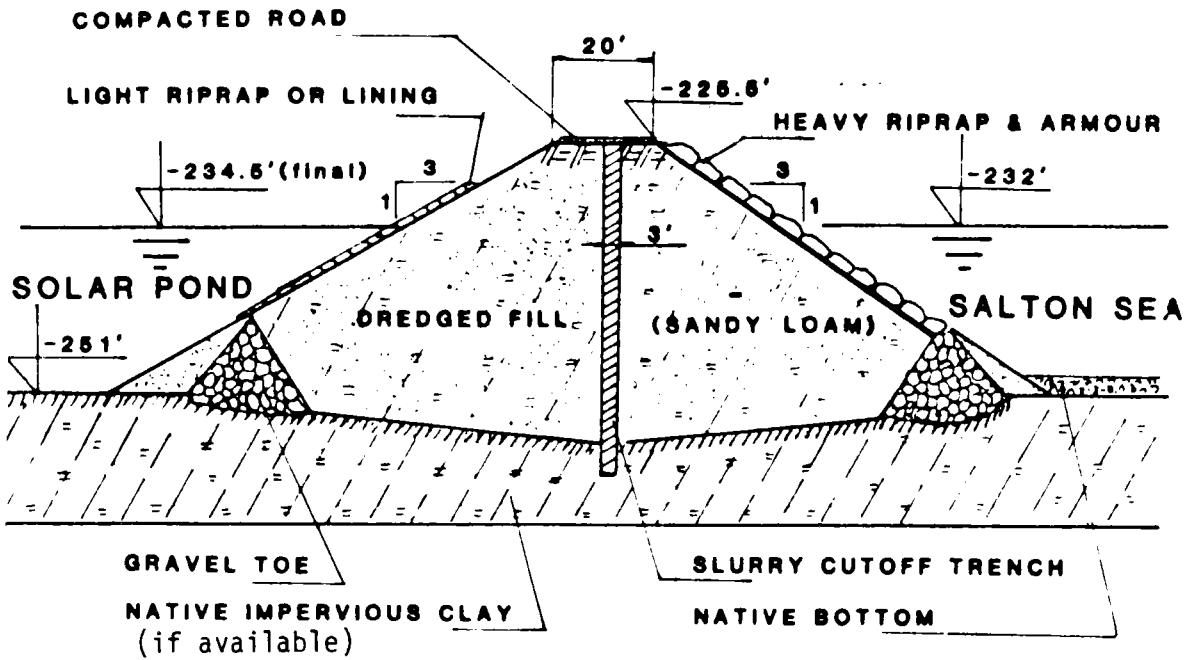
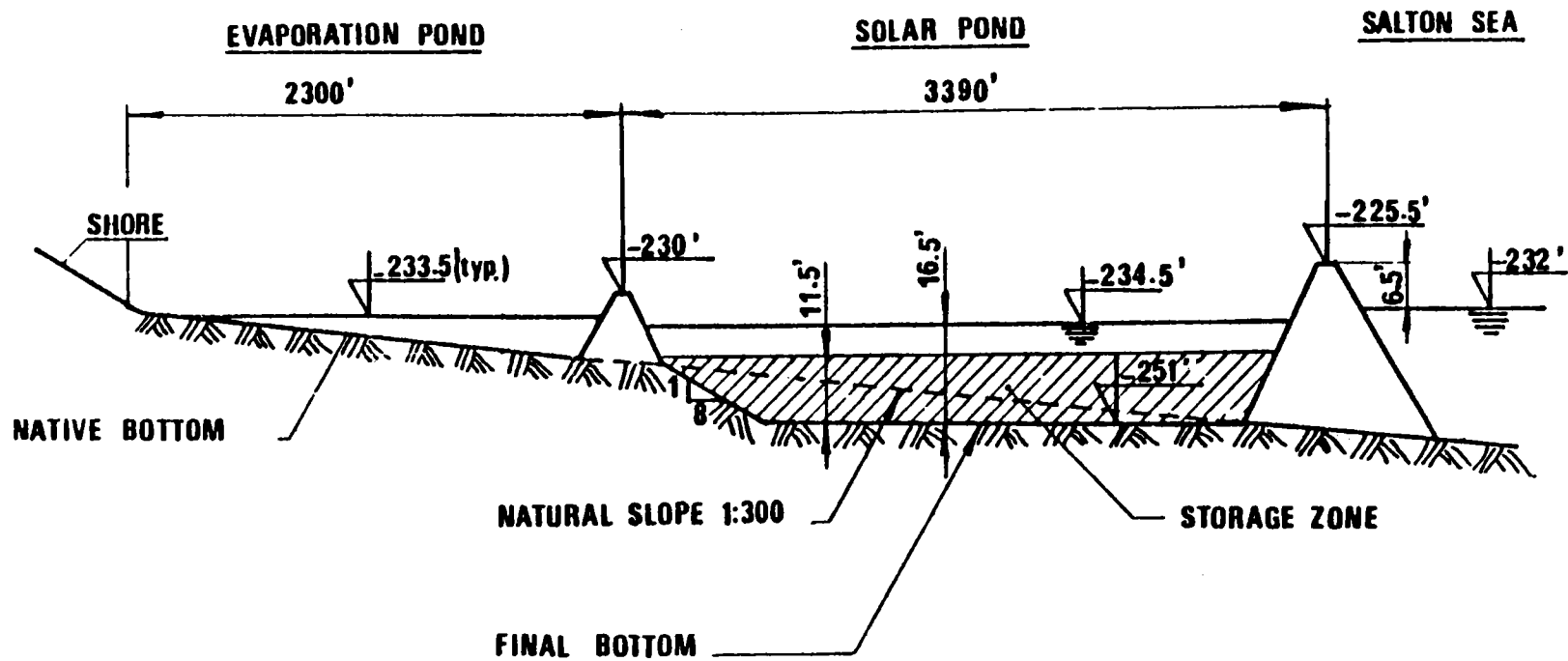

Figure 23. Conceptual Earthfill Dikes Schematics for the Salton Sea Solar Pond (Reference 14)



6-4

Figure 24. A Typical Cross Section Showing Salton Sea and the Solar and Evaporation Ponds (Reference 14)

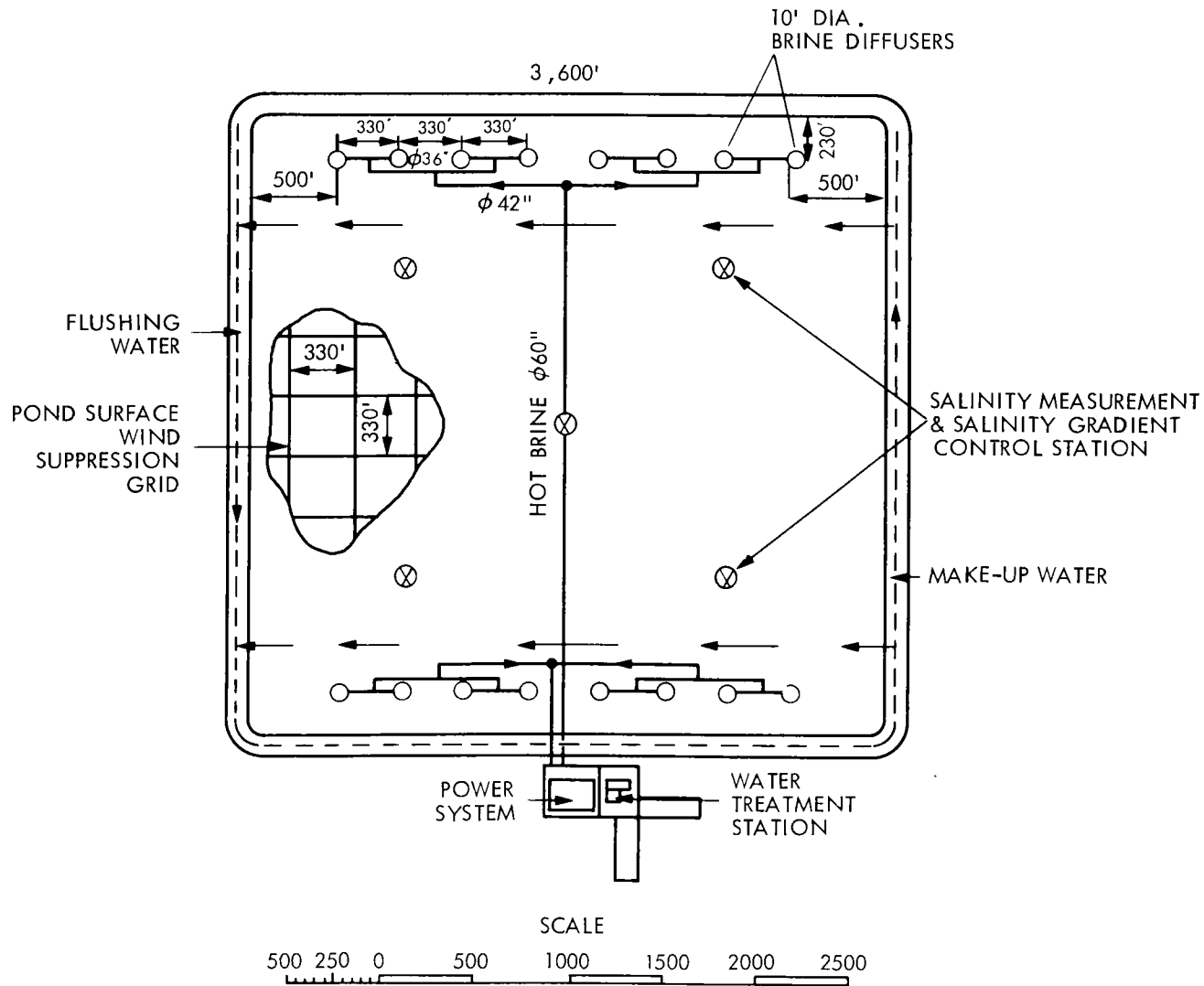

Figure 25. Conceptual Arrangement at the 5-MW_e Salton Sea Solar Pond Power Plant (Reference 14)

B. COSTS

The Farm Science Review Pond ($200 \text{ m}^2 \times 2.5 \text{ m}$) was constructed in 1975 with donated salts and volunteer labor. Nielsen estimated then that the commercial construction cost would be \$7,500 (Ref. 6) or $\$37.5/\text{m}^2$ (1975 dollars). The Miamisburg Pond ($2020 \text{ m}^2 \times 3.5 \text{ m}$) has cost a total of \$70,000 (1977 dollars) to construct, which includes the cost of 1,100 tons of salt at \$17.60/ton; this is equivalent to $\$35/\text{m}^2$ for a depth of 3.5 m. Recently, Fynn indicated (Ref. 21) that the construction cost for the planned one-acre TVA Pond in Chattanooga, Tennessee, is estimated to be about $\$80/\text{m}^2$.

A summary of solar pond cost estimates is provided in Table 3. Both small and large pond cost-estimates are presented. The small pond estimates are made on the basis of a 4047-m^2 (one-acre) pond with a 4.7-m (15.5-ft) depth. Unit cost data used in the estimation are: land at \$5,000/acre; 5,740 tons of salt at $\$0.03/\text{kg}$ ($\$30/\text{ton}$); excavation at $\$1.96/\text{m}^3$ ($\$1.5/\text{yd}^3$); diking at $\$1.57/\text{m}^3$ ($\$1.2/\text{yd}^3$); liner installed at $\$7.53/\text{m}^2$ ($\$0.7/\text{ft}^2$). Based on these and an allowance of \$25,000 for instrumentation and miscellaneous items, a total construction cost of \$305,000 is estimated for the one-acre pond, which is equivalent to $\$75/\text{m}^2$. Comparing this estimate with the cost figures cited above for the FSR, Miamisburg and TVA Ponds, with considerations given to the difference between the pond depths and dollar values, the $\$75/\text{m}^2$ figure appears realistic. This is presented in Table 3(A) as Case 1. If salt is available at no cost (e.g. local salt deposit), as is the case with some locales, then the construction cost can be reduced to $\$48/\text{m}^2$, as shown under Case 2 in Table 3(A). Furthermore, if cheaper labor or existing impoundment is available, the excavation/diking cost can be lowered. This will further reduce the total construction cost to $\$31/\text{m}^2$, as shown under Case 3 in Table 3(A). Cases 1, 2 and 3 can be looked upon as representing locations of differing conditions that impact the construction cost of ponds.

The economics of large electricity-generating ponds is quite different than that of small, thermally-oriented ponds. As can be seen from Table 3(B), a significant fraction of the total power plant construction cost is ascribed to the power generating system, and this fraction increases as the size of the power plant gets larger. Table 3(B) is extracted from results of the Salton Sea Feasibility Study (Ref. 14). Included in the solar pond system cost are costs of such items as solar ponds, evaporation ponds, brine make-up and circulation subsystems, cooling and flushing subsystems, water treatment plant, control equipment, engineering, administration, etc. Power generating system cost includes cost of turbogenerators, heat exchangers, feed pumps, materials, engineering, administration, etc.

Three cases are listed in Table 3(B). The 5-MW_e Salton Sea power plant case is based on in-sea construction, and the construction cost varies according to whether the construction materials are obtained from the pond site within the sea or from the shore a short distance away. Bristol Lake lies in a valley-like depression southeast of the central part of the San Bernardino County, California, and is covered with a surface layer of white, crusted salts. Layers of clay and salts underlie the dry lake bed. The 5-MW_e Bristol Lake power plant case represents dry-land construction on locations that possess many of the necessary solar pond ingredients. Dry-land construction is generally less costly than wet-site

Table 3. Solar Pond Cost Estimates (in 1981 dollars)

A. Small Pond (1-acre x 15.5 ft) for Thermal Applications

<u>Cost Item</u>	<u>Case 1</u>	<u>Case 2</u>	<u>Case 3</u>
Land (10 ³ \$)	5	5	5
Excavation/Diking (10 ³ \$)	120	120	50***
Salt (10 ³ \$)	110	+++	+++
Liner (10 ³ \$)	45	45	45
Intrumentation & Miscellaneous (10 ³ \$)	25	25	25
Total Pond Construction (10 ³ \$)	305	195	125
Unit Pond Construction (\$/m ²)	75	48	31

B. Large Pond for Electric Power Production

<u>Cost Item</u>	<u>Salton Sea 250-Acre 5-MW_e Plant</u>	<u>Bristol Lake 250-Acre 5-MW_e Plant</u>	<u>Salton Sea 26400-Acre 600-MW_e Plant</u>
Solar Pond System (10 ⁶ \$)	14*-18**	9+-18++	558
Power Generating System (10 ⁶ \$)	8	8	540
Total Power Plant Construction (10 ⁶ \$)	22-26	17-26	1098
Unit Pond Construction (\$/m ²)	14-18	9-18	5
Electric Energy (\$/kW Installed)	4400-5200	3400-5200	1830

*** Reduced Labor Cost

+++ Local Salts Available At No Cost

* Construction Material Obtainable From Within The Sea

** Construction Material Available On Shore

+ Liner Not Required

++ Liner Required

construction if pond liners are not required. The 600-MW_e Salton Sea power plant case gives the cost estimate for a large, commercial solar pond power plant. As shown in the table, the unit pond construction cost and the cost of electric energy from a solar pond power plant diminishes with increasing plant size. Also note that if an additional 5-MW_e plant were to be built adjacent to the first 5-MW_e plant, either at the Salton Sea or Bristol Lake site, many of the cost elements could be eliminated or substantially reduced. This would allow the construction cost to be reduced by 10 to 25% from the estimates given in Table 3(b).

Costs of delivered energy from solar ponds based on the above capital cost estimates and various financial parameters were analyzed for different regions in the United States (Ref. 22). The three most important pond-energy cost drivers were identified to be the initial capital cost, pond energy output and discount rate. Estimated in 1981 dollars and for ponds with a 1990 start-up schedule, the costs of delivered thermal energy from ponds range from \$6/MBtu to \$61.9/MBtu. The lower estimate is associated with a pond capital cost of \$31/m², a discount rate of 11%, and an energy yield level typical of the Southwest region. The higher estimate is associated with a pond capital cost of \$87/m², a discount rate of 20%, and an energy yield level typical of the Atlantic Northeast region. Based on a discount rate of 11% and capital cost estimates for the 600-MW_e commercial-size solar pond power plant at the Salton Sea, Reference 22 also calculated the busbar electric power costs to be between 8.5¢/kWh (Southwest region) and 25.9¢/kWh (Atlantic Northeast region). In general, near-term economic viability is attainable for solar ponds in the southern high-insolation regions. Readers are referred to Reference 22 for an extensive treatment of solar pond economics in the various regions of the United States.

SECTION VII

RESEARCH AND DEVELOPMENT NEEDS

As alluded to in earlier sections, the salt-gradient solar pond technology, while proven feasible and attractive, still needs a great deal of study and improvement. There are numerous areas where further research and development effort will be required. Many specific areas needing R&D attention have been identified and discussed by Nielsen (Ref. 1), Sargent and Neeper (Ref.23), Meyer (Ref.24), Sargent (Ref. 25), and Neeper (Ref. 26). The following delineation includes those that have been previously discussed and areas/perspectives that have been only recently recognized.

A. PHYSICS AND CHEMISTRY

- (1) Water Treatment. Treatment of solar pond brine to reduce turbidity and coloration is important (Ref. 18). As mentioned in Section V, proper treatment can improve the transmission of solar radiation into the storage zone, thereby significantly increasing the pond energy output. Turbidity and coloration problems are site specific. Larger, electricity-producing ponds may be more susceptible to these problems because they tend not to use liners, and they exploit locally available salts or brine which can have complex chemical compositions and biological organisms. Causes of turbidity and coloration need to be understood, and techniques for their removal must be determined.
- (2) Mud-Brine Reaction. In unlined ponds, such as the Salton Sea Pond, direct contact between the pond floor and hot brine may cause chemical reaction, resulting in gas bubbling or rising sediment.¹ The former may interfere with gradient stability and the latter will degrade the brine transparency. Again, this problem is site specific, and the site-specific and general aspects of the problem must be investigated by laboratory testing.
- (3) Salt Diffusion Measurement. Salt diffusion rates reported by different investigators range from as low as 10 kg/m²-yr to as high as 130 kg/m²-yr (Ref. 9, 19, 20). The causes for the disagreement are not clear, although there are several interpretations (e.g., sloping-wall effect and Soret effect²) that must be investigated. Accurate data for salt diffusion rate are essential because the frequency of salt replenishment and surface flushing depends on them. Also, accurate modeling of the double-diffusive processes requires this information.
- (4) Evaporation. Evaporation leads to water loss. In some parts of the country this may exceed 1.8 m/yr, which may be intolerable in water-scarce areas. Suggestions have been made to apply evaporation suppressants to the pond surface, but little testing has been done. Evaporation also

¹ Private communication with H. E. Marsh, 1981.

² The effect of temperature gradient on mass diffusion.

contributes to the mixing process in the surface zone, but few details are known about the extent of this effect or the basic mechanisms involved. Furthermore, the physical parameters affecting the rate of evaporation (e.g. temperature and salinity of brine, ambient dry-bulb temperature, wind speed, relative humidity, etc.) are inadequately understood. Analytical and experimental studies are required to gain a better understanding which will impact on the timely and economic production of concentrated brine from low-salinity brackish water for large ponds such as the Salton Sea facility.

B. HYDRODYNAMICS AND HEAT TRANSFER

- (1) Surface-Zone Phenomena. The surface convective zone is present due to the combined effects of wind, evaporation, precipitation, freezing, diurnal heating and cooling, etc. Little is known about the relative magnitude of these separate effects, the mixing mechanisms in the zone, and the effect of surface zone growth on the gradient zone stability. However, it is known that a large surface zone is detrimental to the pond efficiency as its insulating value is low and the solar radiation it absorbs is unusable. It has been estimated that a 10-cm reduction in the thickness of the surface zone can increase the energy output of a solar pond by 6-12%. Analytical, numerical and experimental investigations must be conducted to deal with this problem area in order to establish surface-zone control methods and improve pond performance.
- (2) Gradient-Zone Behavior. The stable behavior of the gradient zone is the key to successful operation of a solar pond, as has been pointed out earlier. The double-diffusive processes occurring within this zone are complex and need further investigation. Although gradient stability and restorability have been demonstrated by the existing ponds under normal operating conditions (Section III, B), the behavior of the gradient zone under more severe conditions (e.g. extreme climate, enormous heat extraction for peak power generation, etc.) remains unknown. Bounds on the severity of pertinent conditions must be established to ensure gradient-zone stability. Also, factors controlling the growth of this zone are not well-understood. While a thicker gradient zone may provide greater insulation, it would also absorb more solar radiation (unusable) and reduce solar transmittance into the storage zone. What is the optimum thickness for the gradient zone? How can the migration of the gradient zone boundaries be effectively controlled? These questions need to be answered.
- (3) Heat Extraction. Different end uses require different modes of heat extraction. For example, space heating, crop drying, base-load and peak power generation impose different extraction schedules and intensities on the pond. The pond's response, in terms of its hydrodynamic behavior and energy balance, varies according to the demand and where the extraction diffusers are located. Optimal heat extraction schemes must be established to suit different applications and to make best use of the pond's energy reserve.

- (4) Hydrodynamic Scaling. To what extent can the findings and experiences from a 10-m² pond be applied to a 1,000-m² pond, and from a 1,000-m² pond to a 1-km² pond? What is the maximum size pond that can be practically built? If adequate scaling laws are determined, or sufficient confidence is gained with respect to scaling up, then R&D dollars can be saved in employing smaller instead of larger experimental ponds. Furthermore, construction dollars can be saved by building very large ponds without costly intermediate diking. At present, very little is known about hydrodynamic scaling of ponds.
- (5) Heat Loss to Earth and Atmosphere. As indicated in Figure 16, heat losses from a 1-km² pond to the surrounding earth and atmosphere amount to 86% of the incident energy, under the assumed conditions (Section IV). Parameters related to heat transfer between the pond and its surroundings, and methods for reducing heat losses are worth looking into.

C. DESIGN AND PERFORMANCE ANALYSIS

- (1) Performance Modeling. Computer models for predicting the thermal performance or thermal and hydrodynamic behavior of solar ponds have been developed or are under development at various institutions in the U.S. and Israel, including JPL, LASL, SERI, ANL, University of New Mexico, University of Utah, Utah State University, Ormat and others. The models vary in complexity and utility. Most thermal performance models solve the one dimensional heat-conduction equation, and are simple and easy to run. They are suitable for preliminary design under normal operating conditions, and unsuitable for situations involving unusual fluid flow conditions or zone boundary migrations. The more sophisticated models are intended to deal with the latter class of problems, but may or may not be successful in achieving their goals because the state of numerical analysis techniques for multi-dimensional fluid flow and heat transfer problems may not have reached the required level of adequacy. More developmental effort is required with these models. One area which all models, simple or sophisticated, must focus on is validation against actual pond performance data. This has not been adequately pursued to date.
- (2) System Optimization. Small pond systems are relatively straightforward and system optimization is not too involved. Large pond systems, however, particularly those built to generate electric power, can be very complicated (Section VI, B). Sizing and costing of components and integration of the system must be executed with care to achieve optimum results. An adequate optimization methodology must be established.

D. CONSTRUCTION TECHNIQUES

Construction of small ponds are relatively straightforward as learned from experiences with the existing ponds. However, large ponds, especially the electricity-generating ones, require some innovation in certain construction areas. For example, the Salton Sea pond has been faced with two major challenges.

- (1) Brine Concentration. The production of a large quantity of concentrated brine ($4.2 \times 10^6 \text{m}^3$ or 3400 acre-feet at specific gravity near 1.22) from the locally available, low-salinity brine (35,000 ppm) requires high cost, large acreage evaporation ponds, and an extended period of time. Enhanced evaporation techniques, such as spray evaporation or others, must be developed to reduce these requirements and gain economic benefits.
- (2) Dike Construction. Innovative techniques for constructing in-sea earth-fill dams and using locally-available earth materials are essential and must be developed, since they will save construction dollars and time while not sacrificing the dike strength.

These and other construction issues that may be site-specific or common to all large ponds will need special attention once they are identified.

E. OPERATION AND MAINTENANCE

U.S. experience in operating and maintaining solar ponds has been limited to existing small ponds. The Israeli experience in operating and maintaining somewhat larger, electricity-generating ponds is also limited by these ponds' brief history. The state of knowledge can and should be improved by further R&D effort as regards gradient maintenance, salt replenishment, surface flushing, transparency upgrading, dirt and debris removal, biological growth control, wave suppression, etc. Automated operation and maintenance of large pond systems, to the extent practical, are also highly desirable.

F. APPLICATIONS

Prototype ponds dedicated to space and water heating, crop drying, farm shelter heating, industrial process heating, space cooling, desalination, ethanol production, sewage treatment process heating, greenhouse heating, electricity generation, etc., either exclusively or in a selected hybrid fashion, must be installed and operated to gain practical experience. Advanced electric power conversion systems or components, and air/water heat exchangers suitable for solar-pond thermal applications are among the items that require R&D effort.

G. MATERIALS

Materials research and development is needed in many important areas. For example:

- (1) Liner or ground sealer that is durable and compatible with hot-brine environment.
- (2) Inexpensive salts or salt replacement.
- (3) Piping and heat exchanger materials that resist corrosion and fouling.
- (4) Inexpensive and high-strength dike construction materials.

H. NEW CONCEPTS

Two examples can be named:

- (1) Floating ponds that can be constructed on a body of deep water and that can be employed in coastal areas or on oceans.
- (2) Saltless ponds that incorporate innovative devices to substitute for the salt gradient and that avoid costly acquisition of salts and the potential of salt contamination hazards.

These have been occasionally mentioned, but not yet actively pursued. Innovative concepts can bring the salt-gradient solar pond technology into a new era and should be encouraged.

SECTION VIII

CONCLUDING REMARKS

As an emerging technology, salt-gradient solar ponds have recently stimulated a significant amount of interest and enthusiasm among the general public and potential users. Two major attractive features of solar ponds are: (1) Ponds comprise four basic ingredients: sunshine, land, water and salts. These are natural endowments which, unlike some elements of other energy-producing options, pose little threat to humans and their environment; (2) Solar ponds combine a collector and large thermal storage in one, and can supply low-cost thermal energy or electric power to a variety of end uses at any time of the day or year.

Owing to the endeavor and achievements of the U.S. and Israeli pioneers during the last seven years or so, solar ponds have been proven to be a technically feasible, environmentally benign, and economically attractive energy-producing alternative. Experiences from more than a dozen existing ponds, both in the U.S. and Israel, have shown that ponds do work, and that they are reliable and easy to operate and maintain. Solar ponds can be adapted to many practical applications, and they may be able to produce thermal energy and electric power at costs which will be competitive with other energy sources.

The solar pond technology, however, is still in its infancy, and much needs to be done to bring it to maturity. Specific R&D areas that need to be addressed have been identified and discussed, both from the perspectives of smaller, thermally-oriented ponds and larger, electricity-generating ponds. These areas require the attention and action of technical workers as well as decision makers.

REFERENCES

1. ✓ Nielsen, C.E., "Nonconvective Salt Gradient Solar Ponds", Solar Energy Technology Handbook, Chapter 11, pp. 345-376. Edited by Dickinson, W.C. and Chermysinoff, P.N., Marcel Dekker, 1980.
2. ✓ Zangrando, F. and Bryant, H.C., "A Salt Gradient Solar Pond", Solar Age, pp. 21-36, Apr 1978.
3. ✓ Bronicki, Y.L., "The Solar Pond Development Program in Israel", Proc. Non-convecting Solar Pond Workshop, p. 12-1 to p. 12-2b, July 1980.
4. ✓ Bronicki, Y.L., "A Solar Pond Power Plant", IEEE Spectrum, pp. 56-59, Feb 1981.
5. ✓ Wittenberg, L.J. and Harris, M.J., "The Miamisburg Salt-Gradient Solar Pond", Proc. Non-convecting Solar Pond Workshop, p. 13-1 to p. 13-15, July 1980.
6. ✓ Nielsen, C.E., "Experience with a Prototype Solar Pond for Space Heating", Proc. Jt. Conf. of the Int. Solar Energy Soc., Am. Sect. and Solar Energy Soc. of Canada, Winnipeg, Canada, Vol. 5, pp. 169-182, 1976.
7. ✓ "OARDC Solar Pond Update", International Solar Pond Newsletter No.2. Edited by Ochs, T., Feb 1980.
8. ✓ Nielsen, C.E., "Design and Initial Operation of a 400 m² Solar Pond", Proc. AS/ISES Annual Meeting, Phoenix, Arizona, Vol. 3.1, 1980.
9. ✓ Zangrando, F., "Observation and Analysis of a Full-Scale Experimental Salt Gradient Solar Pond", Ph.D. dissertation, The University of New Mexico, Albuquerque, May 1979.
10. ✓ Weeks, D.D., et. al., "What Happens When a Solar Pond Boils?", International Solar Pond Newsletter No. 4. Edited by T. Ochs, Jan 1981.
11. ✓ Witenberg, L.J. and Harris, M.J., "Evaluation of a Large Nonconvective Solar Pond", Proc. Solar Energy Storage Options Workshop, Mar 1979.
12. ✓ Fynn, R.P. and Short, T.H., "Monitoring Sodium Chloride Concentrations and Density Profiles in Solar Ponds by Electrical Conductivity and Temperature Measurement", Proc. AS/ISES Annual Meeting, Vol. 3.1, pp. 386-390, 1980.
13. Lin, E.I.H., Sha, W.T. and Soo, S.L., "Stability Considerations and a Double-Diffusive Convection Model for Solar Ponds", ANL-CT-79-34, Apr 1979.
14. Ormat Turbines, Ltd., "A Study of the Feasibility of a Solar Salt Pond Generating Facility in the State of California, U.S.A.", Vol. I and II, Feb 1981.

15. Lin, E.I.H. and Singer, M.J., "An Evaluation of the Feasibility of a Salt-Gradient Solar Pond for Space Heating at Yankton, South Dakota", JPL Internal Document, Apr 1981.
16. French, R.L. and Lin, E.I.H., "Status Report - Salton Sea Solar Pond Power Plant", presented at the 16th Intersociety Energy Conversion Engineering Conference, Atlanta, Georgia, Aug 1981.
17. Ochs, T.L., Stojanoff, C.G. and Day, D.L., "One Year's Experience with an Operating Saturated Solar Pond", Proc. AS/ISES Annual Meeting, Phoenix, Arizona, Vol. 3.1, 1980.
18. Marsh, H.E., et al, "Salt-gradient Solar Ponds in the Salton Sea: Brine Optical Quality and Performance", presented at th 16th Intersociety Energy Conversion Engineering Conference, Atlanta, Georgia, Aug 1981.
19. Tabor, H., "Large-area Solar Collectors for Power Production", Solar Energy, Vol. 7, No. 4, 1963.
20. Weinberger, H., "The Physics of the Solar Pond", Solar Energy, Vol. 8, No. 2, pp. 45-56, 1964.
21. Fynn, R.P., "OARDC Solar Pond Update", International Solar Pond Newsletter No.4, edited by T. Ochs, Jan 1981.
22. Lin, E.I.H., et al, "Regional Applicability and Potential of Salt-Gradient Solar Ponds in the United States," to be published.
23. Sargent, S.L. and Neeper, D.L., "Overview of the DOE National and International Program for Salt Gradient Solar Ponds", Proc. AS/ISES Annual Meeting, Vol. 3.1, Phoenix, Arizona, 1980.
24. Meyer, K.A., "Research and Development to Support Commercialization of Solar Ponds", Proc. Non-convecting Solar Pond Workshop, p. 17-1 to p. 17-8, July 1980.
25. Sargent, S.L., "An Overview of Solar Pond Technology," Proceedings of the Solar Industrial Process Heat Conference, Oakland, Oct. 31-Nov 2., 1979. Also SERI TP-333-429.
26. Neeper, D.A., "Overview of the U. S. Program for Nonconvecting Solar Ponds", Proc. Non-convecting Solar Pond Workshop, p. 11-1 to p. 11-7, July 1980.