

**Evaluation of Veda, Inc.
Central Receiver Solar Collection
System Concept**

Prepared by
Joe Ator
Energy Projects Directorate

August 1981

Prepared for
Solar Energy Division DOE/SAN
THE DEPARTMENT OF ENERGY

Energy and Resources Division
THE AEROSPACE CORPORATION
El Segundo, California

**SOLAR
THERMAL
SYSTEMS**



**THE
AEROSPACE
CORPORATION**

Aerospace Report No.

ATR-81(7981-02)-1

EVALUATION OF VEDA, INC.
CENTRAL RECEIVER SOLAR COLLECTION SYSTEM CONCEPT

Prepared by

Joe T. Ator
Energy Projects Directorate

August 1981

Prepared for

Solar Energy Division DOE/SAN
THE DEPARTMENT OF ENERGY

Contract No.

DE-AC03-81SF-11514

Energy and Resources Division
THE AEROSPACE CORPORATION
El Segundo, California

FOREWORD

This report summarizes the results of an evaluation of a solar energy collection system concept designed by Veda, Inc. The concept falls in the general class of solar thermal central receivers but possesses a geometrical configuration markedly different from that of most central receiver designs.

The study was conducted as a part of technical support to DOE/SAN under Contract No. DE-AC03-81SF-11515 under the general direction of Dr. S. D. Elliott, and under the overall cognizance of Mr. Robert Hughey, Director of Solar Energy Division, San Francisco Operations Office (DOE/SAN).

The engineering evaluation was conducted by Mr. Joe Ator with major contributions from Mr. Phil deRienzo and Mr. Richard Boucher, and additional technical support provided by Dr. Charles Randall and Mr. Jack Elias. The evaluation was conducted under the direction of Dr. Prem Mathur, Director, Advanced Solar Thermal Directorate, Energy Projects Directorate, Energy and Resources Division of The Aerospace Corporation. Mr. Harry Bernstein is the Principal Director of Energy Projects and Mr. Shay Huffman is the Division General Manager.

TABLE OF CONTENTS

	<u>Page</u>
1. INTRODUCTION	1
2. EVALUATION OBJECTIVES	2
3. DETAILED EVALUATION	2
3.1 UNIFIED HELIOSTAT ARRAY	2
3.1.1 AREA EFFICIENCY COMPARISONS	4
3.1.2 FLUX DENSITY DISTRIBUTION	11
3.1.3 FEASIBILITY OF USING A SECONDARY MIRROR	14
3.1.4 SPECIAL APPLICATIONS	19
3.1.5 BEAM SAFETY ASPECTS	22
3.2 VEDA INDUSTRIAL HELIOSTAT	22
3.2.1 OPTICAL DESIGN	22
3.2.2 EQUATORIAL MOUNT	26
3.2.3 MANUFACTURABILITY	28
4. SUMMARY OF EVALUATION	29
4.1 UHA	29
4.2 VIH	30
5. RECOMMENDATIONS	31
6. REFERENCES	33
7. APPENDIX	34

1. INTRODUCTION

In January 1981 the Veda, Inc., division located in Camarillo, California, submitted a study report (Reference A) to the Department of Energy (DOE) summarizing its investigations of a novel approach for the optical collection and concentration of solar radiation. The approach involves a particular type of geometrical array of heliostats and a particular heliostat design for use in that array. These two concepts are identified by Veda as follows:

(1) Unified Heliostat Array (UHA)

- a geometrical heliostat field layout in which rows of mirrors are placed at various levels (terraces) in a configuration resembling athletic field bleachers for the purpose of redirecting solar radiation to a point near ground level.

(2) Veda Industrial Heliostat (VIH)

- a toroidal segment mirror mounted on an equatorial mount. The rectangular mirror surface is curved with two orthogonal radii selected to concentrate radiation and minimize image spreading due to optical aberrations created by off-axis tracking of the sun. The VIH design proposed is relatively small, 2x3 m, or approximately 10-15% of the area of a DOE "Repowering" heliostat.

The UHA is a collection concept which could be used with different heliostat designs with varying degrees of collection efficiency, but is claimed to be most effective with the Veda VIH design. The VIH heliostat configuration differs from the conventional DOE "Repowering" heliostats which are 6-10 times larger in area, employ an azimuth-elevation drive, and contain multiple rectangular mirror panels which can be individually canted and focused along selected axes to make the composite assembly approximate any desired figure.

The UHA and VIH have been evaluated separately. The evaluation objectives and results are presented in Sections 2 and 3, respectively, and the key findings of the evaluation are presented in Section 4.

2. EVALUATION OBJECTIVES

The objectives of this evaluation are to:

- (1) Assess the credibility of the optical designs and the validity of UHA and VIH performance estimates presented by Veda in Reference A.
- (2) Determine what the distinctive features embodied in Veda's UHA and VIH concepts offer that the more conventional central receiver technologies do not:
 - a) For Solar Thermal/SunFuels applications
 - b) For ultra-high temperature, high power density applications (other than power generation or fuel production).
- (3) Determine where the UHA and VIH concepts might be most applicable in DOE's Solar Thermal Program.

3. DETAILED EVALUATION

3.1 Unified Heliostat Array

An artist's concept of the UHA is shown in Figure 1. In contrast to the "power tower" concept incorporated in the Central Receiver Test Facility at Albuquerque, N.M., the 10 MW_e Pilot Plant under construction at Barstow, and in all current candidate system designs in DOE's Repowering Program, the UHA is arranged to concentrate the sun's energy at a point much closer to ground level.

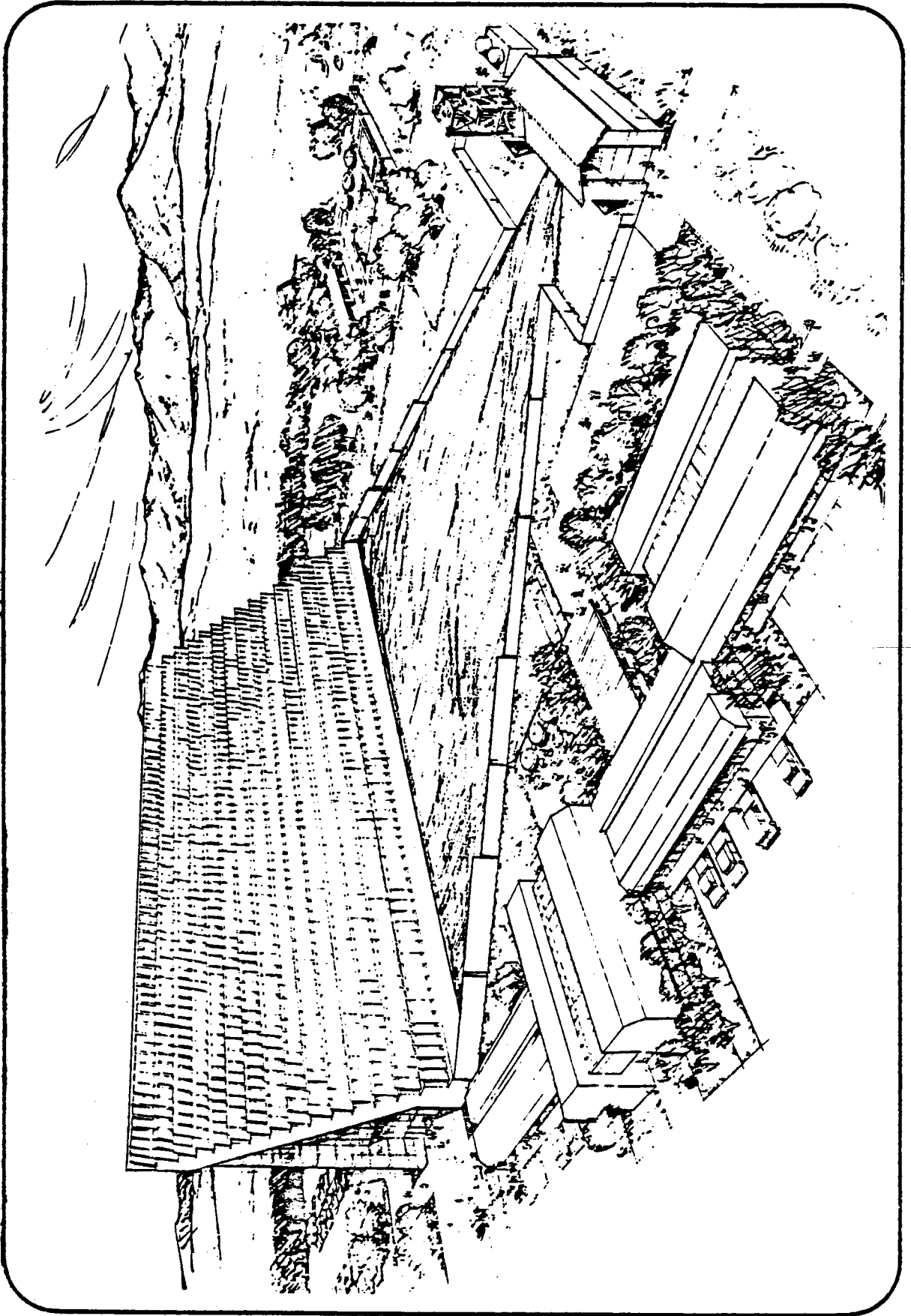

Figure 1. Veda, Inc. Unified Heliostat Array

3.1.1 Area Efficiency Comparisons

A plan view of a typical UHA design described in Reference A is drawn to scale in Figure 2, with central rays from representative heliostat locations illustrated. The sun's rays correspond roughly to an equinox condition at 9:00 a.m. local time. Since the heliostat's basic geometric function is to bisect the angle between the incoming sunlight and the reflected beam to the receiver, any collector design which minimizes that angle also minimizes the angle between the heliostat normal and the sunlight, and thereby maximizes the heliostat area efficiency. The area efficiency is defined as the cosine of the angle between the heliostat normal and the incident sunlight rays. The "cosine losses" increase as this angle becomes larger.

A comparison of the UHA heliostat area efficiencies with those of a conventional north-field central receiver "power tower" array showed that for the same site the UHA will, in general, exhibit lower area efficiencies than those of the power tower array. A power tower example was taken from page I-5 of Reference B, whose configuration is shown in Figure 3. Comparisons for three key days of the year are shown in Figure 4, where the UHA field size example was selected for its comparability in size with the power tower field. The heliostat on the N-S line which is most remote from the receiver and a closer heliostat are illustrated for each case.

It can be seen from Figure 4 that heliostat area efficiency is amenable to some optimization, especially for near-field heliostats, via selection of the height at which the receiver is placed. In contrast, the UHA design necessitates generally larger half-angles, particularly under noonday summer conditions, and will unavoidably exhibit lower area efficiencies. Though receiver height variations are not discussed in Reference A, it would be feasible to place the UHA receiver at a greater height for some applications, in which case this effect will be slightly mitigated.

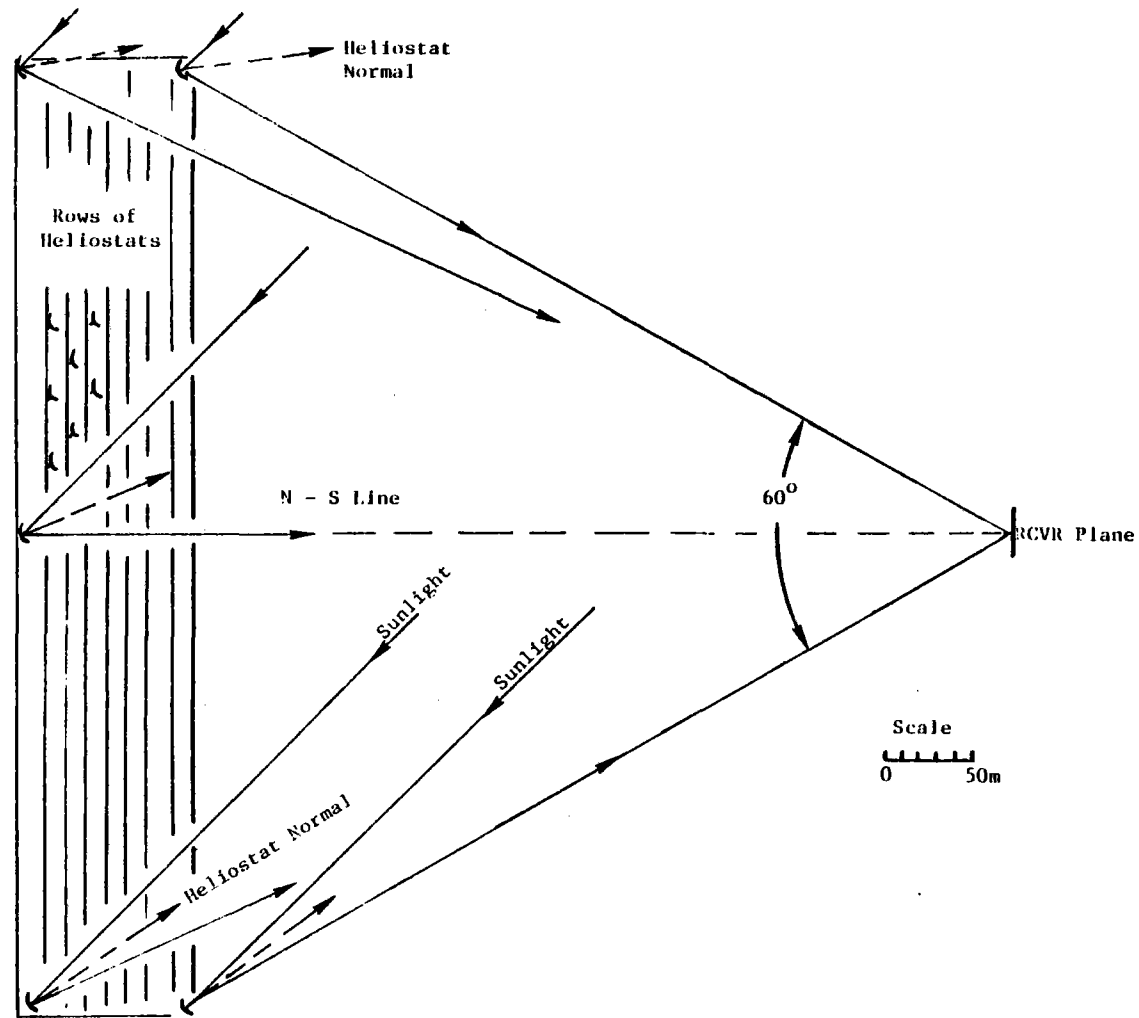

Figure 2. Plan View of UHA Field Concept
(25 MW_t Size)

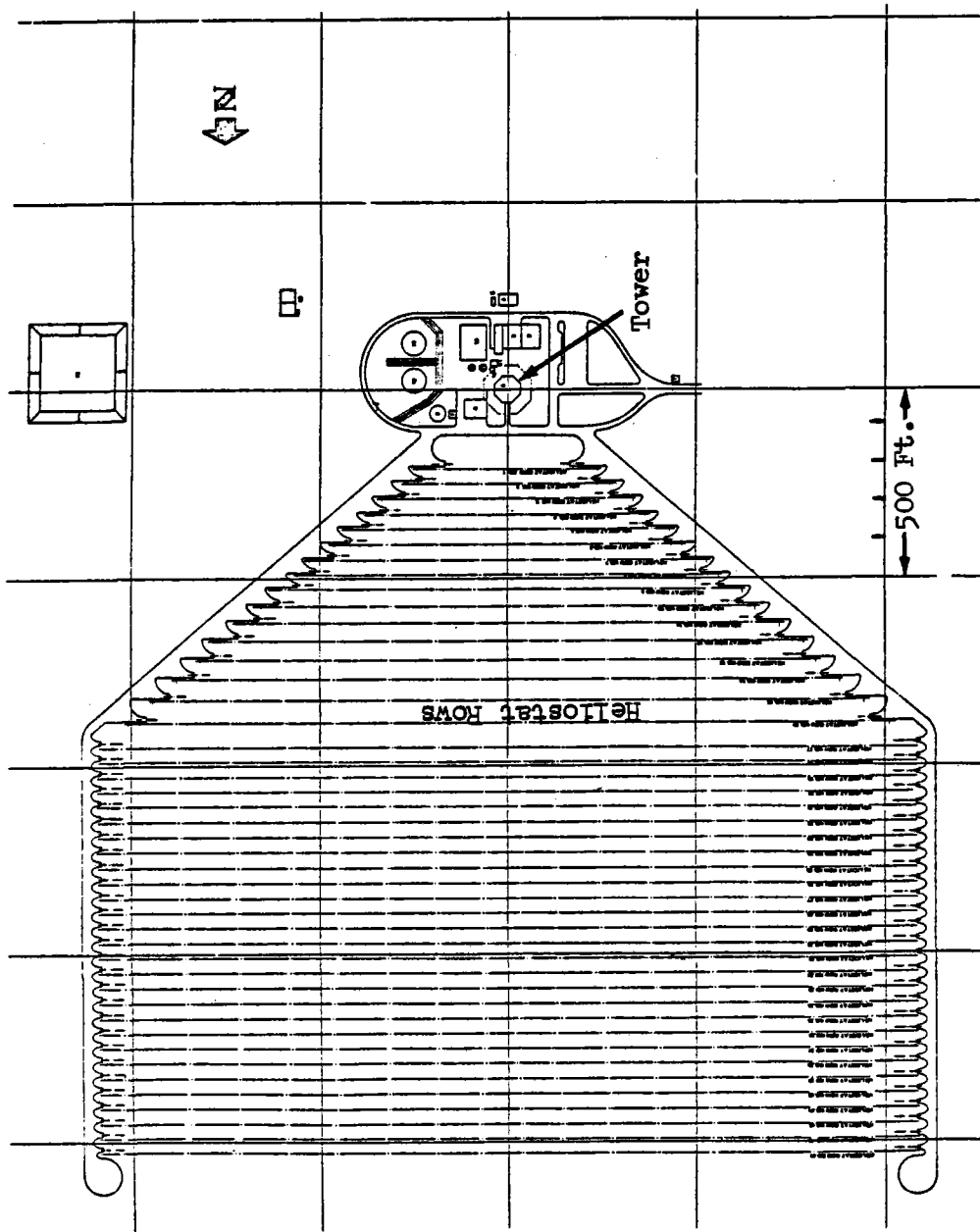

Figure 3 - Representative North-oriented Power Tower Field Layout

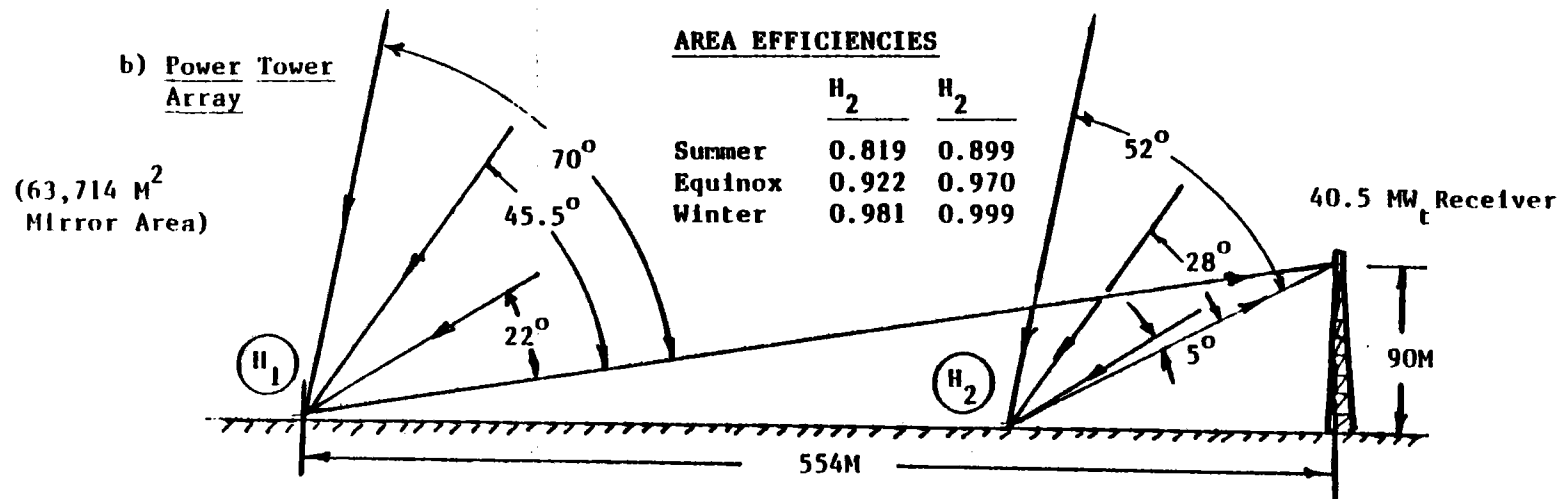
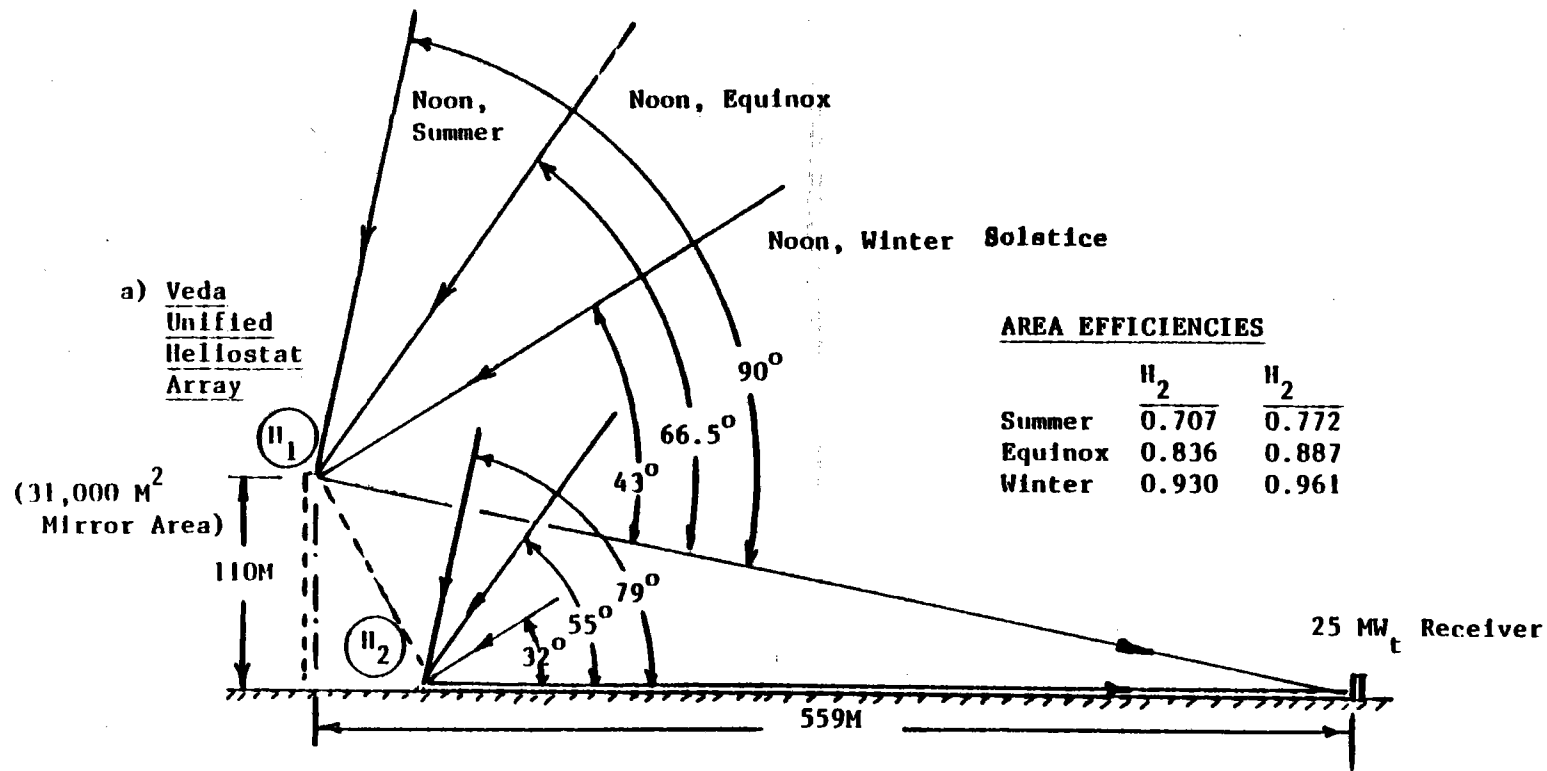

Figure 4 COMPARISON OF HELIOSTAT AREA EFFICIENCIES OF THE VEDA UNIFIED HELIOSTAT ARRAY AND A POWER TOWER ARRAY

(illustrating central rays for selected heliostats lying in a N-S plane which passes through the receiver)

Another operational difference between the UHA and the power tower array affecting collection efficiency is the result of placing the UHA heliostats on a tilted plane at a rather steep angle as opposed to a horizontal heliostat array. As a consequence, for northern latitude sites the UHA will be unable to view the rising and setting sun in midsummer, between spring and fall equinoxes, causing a shorter solar "day" in summer than would be experienced by the horizontal array. The UHA will have full view of winter sunrise and sunset, however. From the spring equinox, the length of the solar day increases as summer approaches for horizontal heliostat arrays and decreases again toward the fall equinox, but it will remain essentially constant for the UHA. The apparent result is that the useful solar day for the UHA will be roughly constant over the year. If the operating "day" is confined to sun elevations above 15° , however, it will be essentially the same for both configurations.

The noonday sun angle geometry for summer, winter, and equinox conditions for 10 MW_t UHA designs from Reference A (page 5-2) using both the Repowering heliostat and the Veda heliostat, is illustrated in Figure 5. Based on the cosines of the bisected angles of the figure, the area efficiencies for the highest heliostats lying in the central north-south plane range from approximately 0.71 to 0.93 for these key days, and are essentially the same regardless of which heliostat type is incorporated in the UHA design. To graphically summarize the area efficiency comparisons, the efficiency values for all the above cases are plotted in Figure 6. It is seen that for the most remote heliostat row, the instantaneous values of the UHA area efficiencies can reach levels about 14 percent below those for a corresponding row of the power tower array. That could reduce collection capability over a year's time by about 11 percent unless it is compensated either by superior optical performance of the VIH heliostats or by mounting the receiver at a higher elevation, e.g., on upper levels

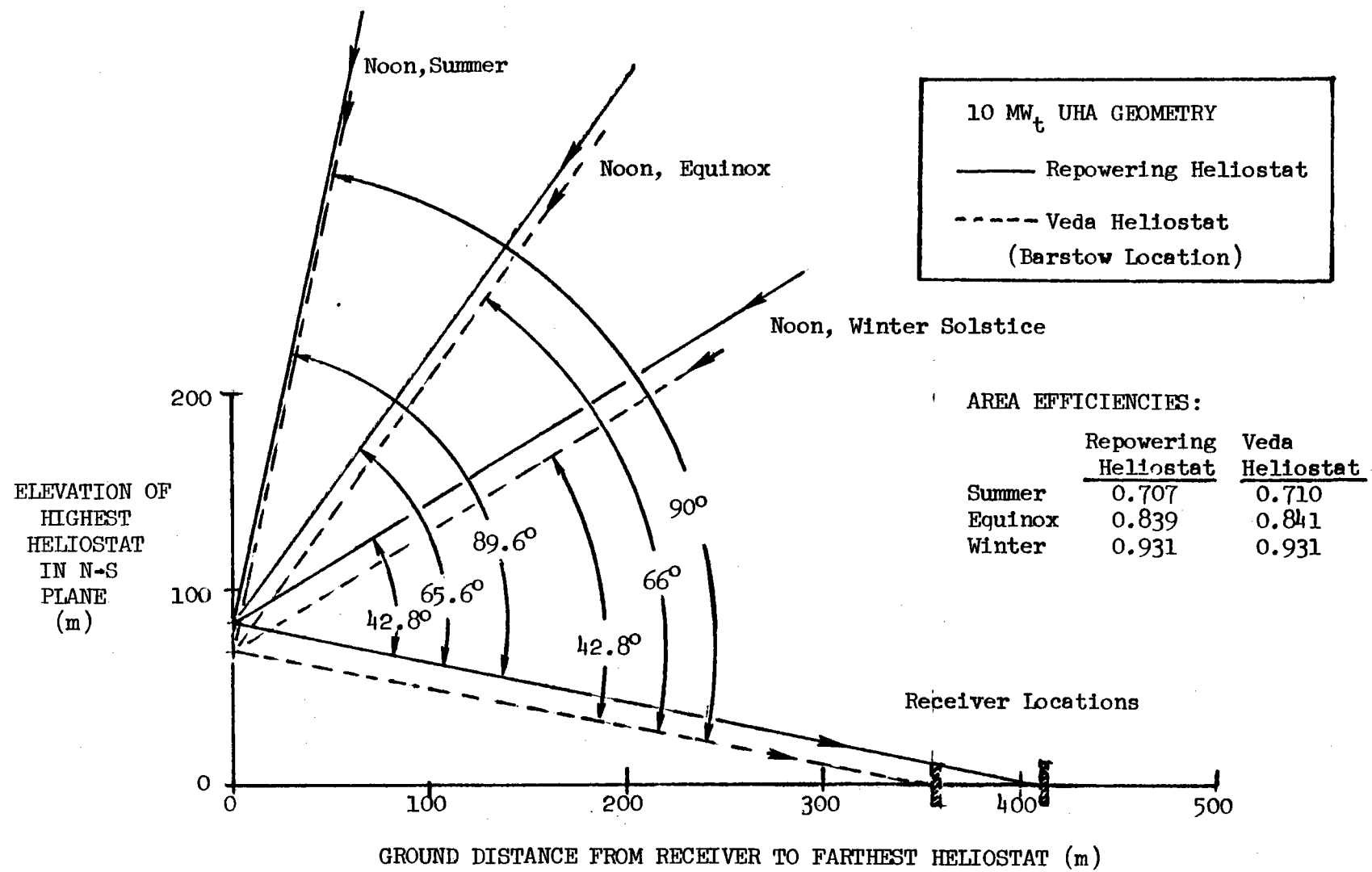

Figure 5. Area Efficiency for a Typical UHA Design

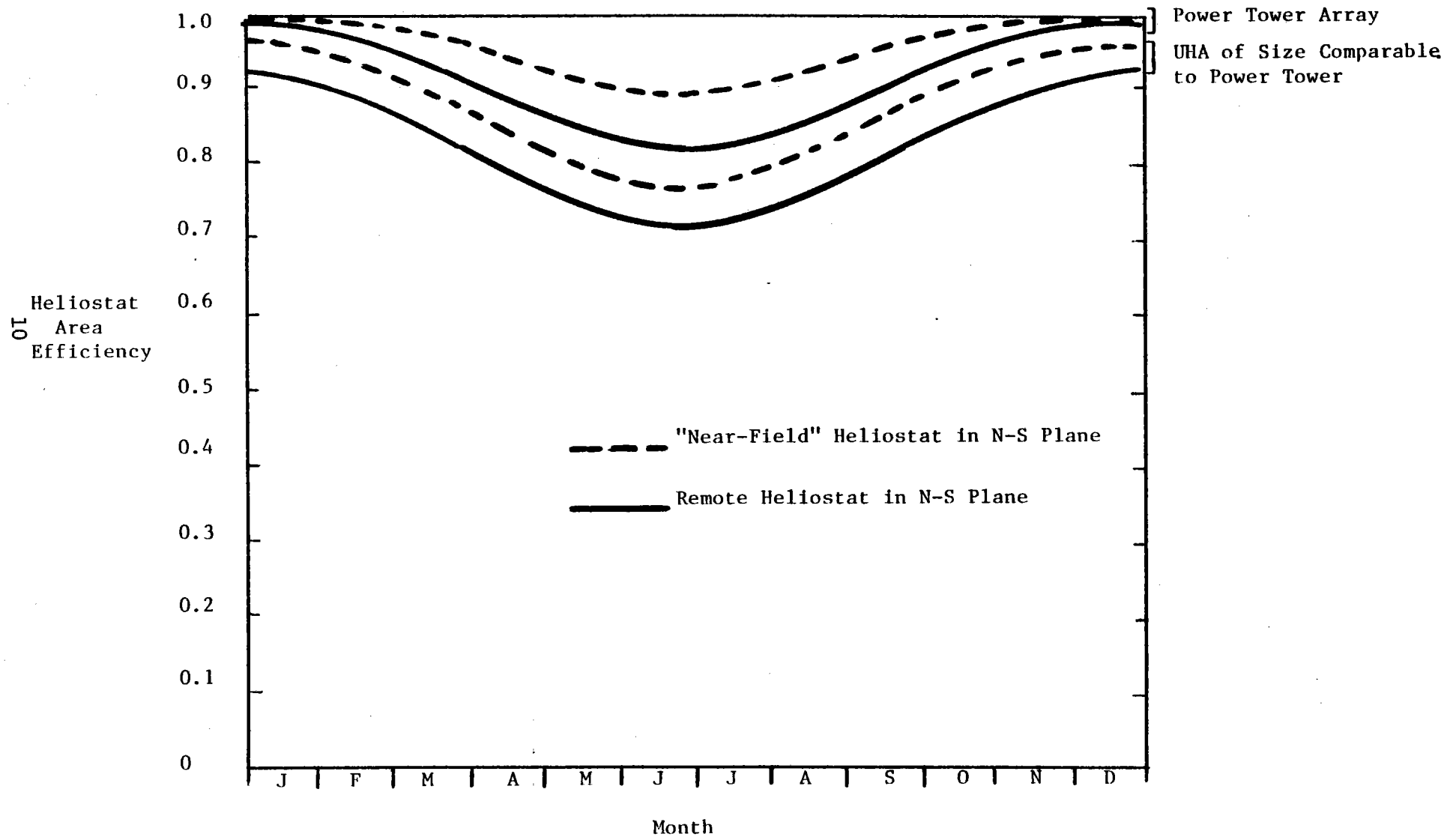

Figure 6. Comparison of Heliostat Array Area Efficiencies (Half-Angle Cosine, Noonday Sun Condition)

of a factory building. Although only heliostats lying in the central N-S plane have been used for area efficiency calculation, the differential comparison is believed to be basically valid for the entire field since the half-angle cosines, and hence the area efficiencies, will be even lower for other heliostat locations.

The land area requirements of the UHA and a north-field "power tower" design of equivalent power level were also compared. The results are $7115 \text{ m}^2/\text{MW}_t$ for the UHA vs. $7300 \text{ m}^2/\text{MW}_t$ for the power tower, a difference of about 2.5 percent. That is not considered highly significant because changes in collector field area due to "fine tuning" of the field geometry and tower height may exceed that amount.

Based on the above comparison of heliostat area efficiencies and solar day viewing times, it is concluded that, with equivalent total mirror area, the UHA will have energy collection performance at least comparable to that of the more conventional power tower arrays during 3 to 4 months of the year (winter), but will exhibit somewhat lower performance for the remainder of the year.

3.1.2 Flux Density Distribution

The flux density at the receiver aperture is determined by a number of factors:

- optical design of the individual heliostats
- configuration of the collector/receiver complexes
- the aiming pattern employed to illuminate the receiver.

In solar thermal repowering systems, the flux density distribution is planned to be compatible with the receiver being used. The peak density at the receiver aperture is limited by system operating

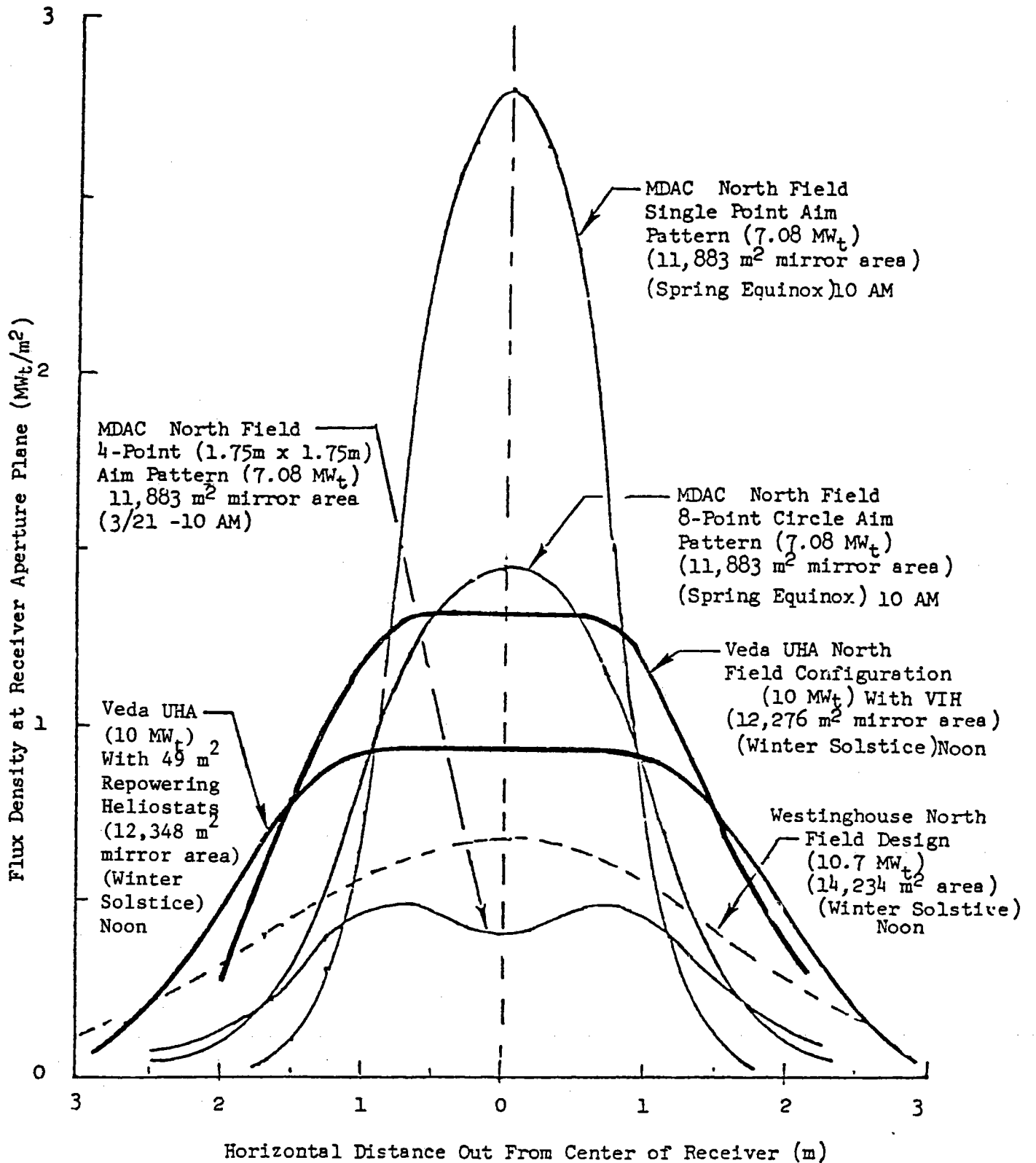

Figure 7. Comparison of Flux Density Profiles

temperature, heat transfer characteristics of the receiver coolant fluid, and allowable temperature limit of the receiver materials. That is obviously not the case with solar furnaces or other non-repowering applications of central receiver systems..

A graphical comparison of a representative Veda UHA flux density profile with those of conventional Repowering array conceptual designs having somewhat comparable power levels is shown in Figure 7. The power levels given in each case represent that power which is incident on the receiver.

Three patterns with different aiming strategies are shown for a McDonnell Douglas (MDAC) North Field design for the 10:00 a.m. spring equinox conditions. As to be expected, the peak power density decreases with spreading of the aim points. The highest flux density shown ($2.8 \text{ MW}_t/\text{m}^2$) would not be practical for use in the electric power generation application intended by MDAC, but illustrates the theoretical capability of such an array for applications that call for extremely high power density in a limited area. The aim pattern ultimately selected by MDAC held the flux density below $0.4 \text{ MW}_t/\text{m}^2$ at any point, to provide proper thermal coupling with the receiver. The upper UHA curve represents a design using the VIH; the UHA design for the lower curve incorporates 49 m^2 Repowering heliostats.

The Veda UHA 10 MW_t profiles shown in Figure 7 are seen to have a broad central peak with rapidly falling sides, which is a desirable match for either external or cavity type receivers. The UHA profiles are more attractive from a design standpoint than the comparable Westinghouse (Reference C) or MDAC (Reference D) design profiles shown. Furthermore, (ignoring differences between equinox and winter solstice conditions) the UHA design using the VIH appears to have a performance advantage in collection capability over the others illustrated, since it collects 815 watts per square

meter of mirror surface whereas the MDAC design produces only 596 W/m² and the Westinghouse design produces 751 W/m². That provides 27% and 8% higher flux levels, respectively, and tends to support Veda's claims that the VIH produces an average flux density at the receiver aperture greater than any heliostat currently under study (for surround fields) and permits the use of the smallest aperture for a given amount of energy collected. In comparing the VIH and the typical Repowering heliostat employed in the UHA configuration, Veda showed in Reference A that the VIH consistently produces a smaller image----4% smaller at 8:00 a.m. and 6% smaller at 12:00 noon (as evident in Figure 7) for the Barstow location. Obviously, the greatest advantage appears at large off-axis conditions.

3.1.3 Feasibility of Using a Secondary Mirror

The feasibility of introducing a secondary mirror in the path of the combined heliostat beams of the UHA, to redirect the energy focus onto a near-horizontal surface for special applications was briefly investigated. The example case selected is the 25 MW_t UHA design which was sketched in plan view on Figure 2 and in elevation view in Figure 4. Vertical cross-sections of the beam pattern arriving at the receiver are plotted in Figure 8 for intersecting planes 0, 10, and 20 meters distant from the receiver plane. It can be seen that any secondary mirror placed in this beam pattern will grow unwieldy in size if it is placed very far out from the original receiver plane.

It is assumed that redirection of the UHA beam by means of a secondary mirror would be required only for certain non-repowering applications. The preferred dimensions of the "receiver" in such applications are not known. As a test case, it will be assumed that a receiver plane having the same dimensions as the original 25 MW_t UHA receiver will be suitable. That can be achieved with 1:1 optics using a flat mirror, as illustrated in Figure 9. The

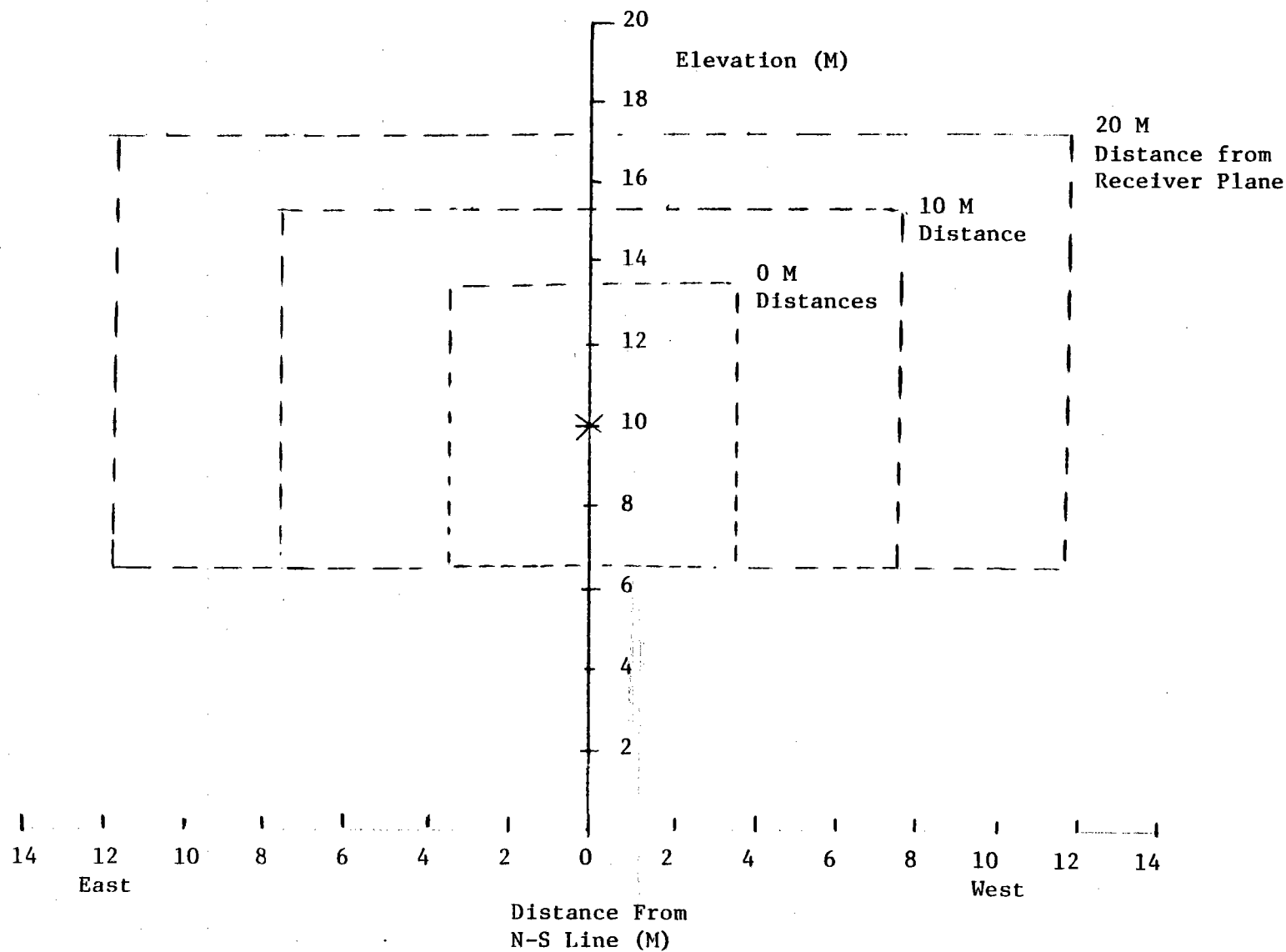
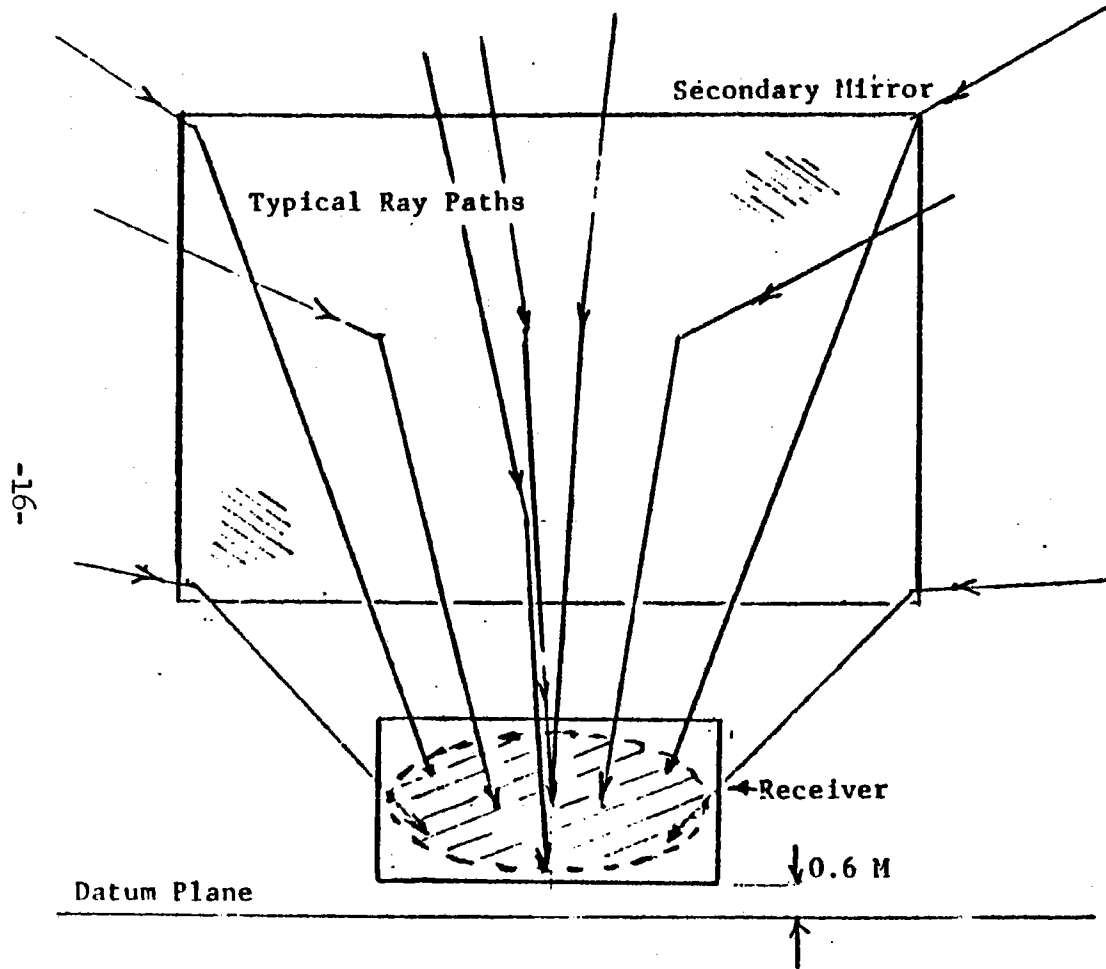

Figure 8. Vertical Cross-Sections of UHA Beam Pattern at Different Distances North of Receiver Plane

ELEVATION VIEW

LOOKING SOUTH



Side Elevation View

of Vertical Cross-Section

Through N-S Line

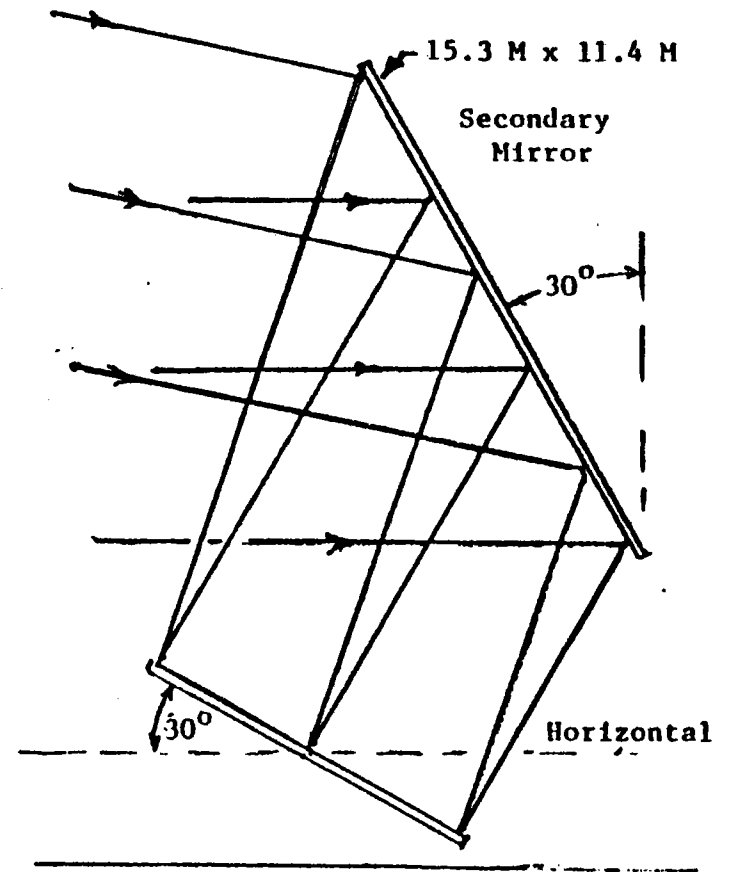

Figure 9. Secondary Mirror Example

resulting receiver plane is tilted at 30° from the horizontal, and essentially all the energy will be incident on a circular area shown as the cross-hatched region. A more detailed picture is shown in Figure 10, showing the relationship to the original UHA receiver position. The highest and lowest heliostat beams arriving in the vertical N-S plane are illustrated. They constitute vertical slices through the axes of expanding cones having half-angles of 0.25 degrees.

The secondary mirror size in this arbitrarily chosen example is 15.3 m x 11.4 m; Figure 10 shows that it could be made only slightly smaller if it is located closer to the original receiver point. Thus, it is concluded that a large size is unavoidable for the secondary mirror.

Because the energy impinging on such a secondary mirror is spread out over an area larger than the receiver, the flux density at that point will be considerably reduced, roughly in proportion to the ratio of areas. Furthermore, since the mirror (in clean condition) will reflect from 91% to approximately 98% of the incident radiation, it will theoretically absorb only a small percent of the energy in the visible portion of the solar spectrum. In any case it will require a good heat sink or radiators on the backside.

It should be noted that the flatness of such a secondary mirror is not critical because image "quality" is not a critical requirement, and some deformation due to heating and/or gravity sag can easily be tolerated with no undue degradation in energy received at the focal plane.

A more detailed analysis of the feasibility of using such a reflector is given in the Appendix (Section 7). It is concluded that use of a secondary mirror to facilitate special applications of the UHA is a feasible idea. Because of the large sizes indicated it would likely be fabricated by assembling several facets

Figure 10 - Detailed View of Plane Secondary Mirror
(30° from vertical)

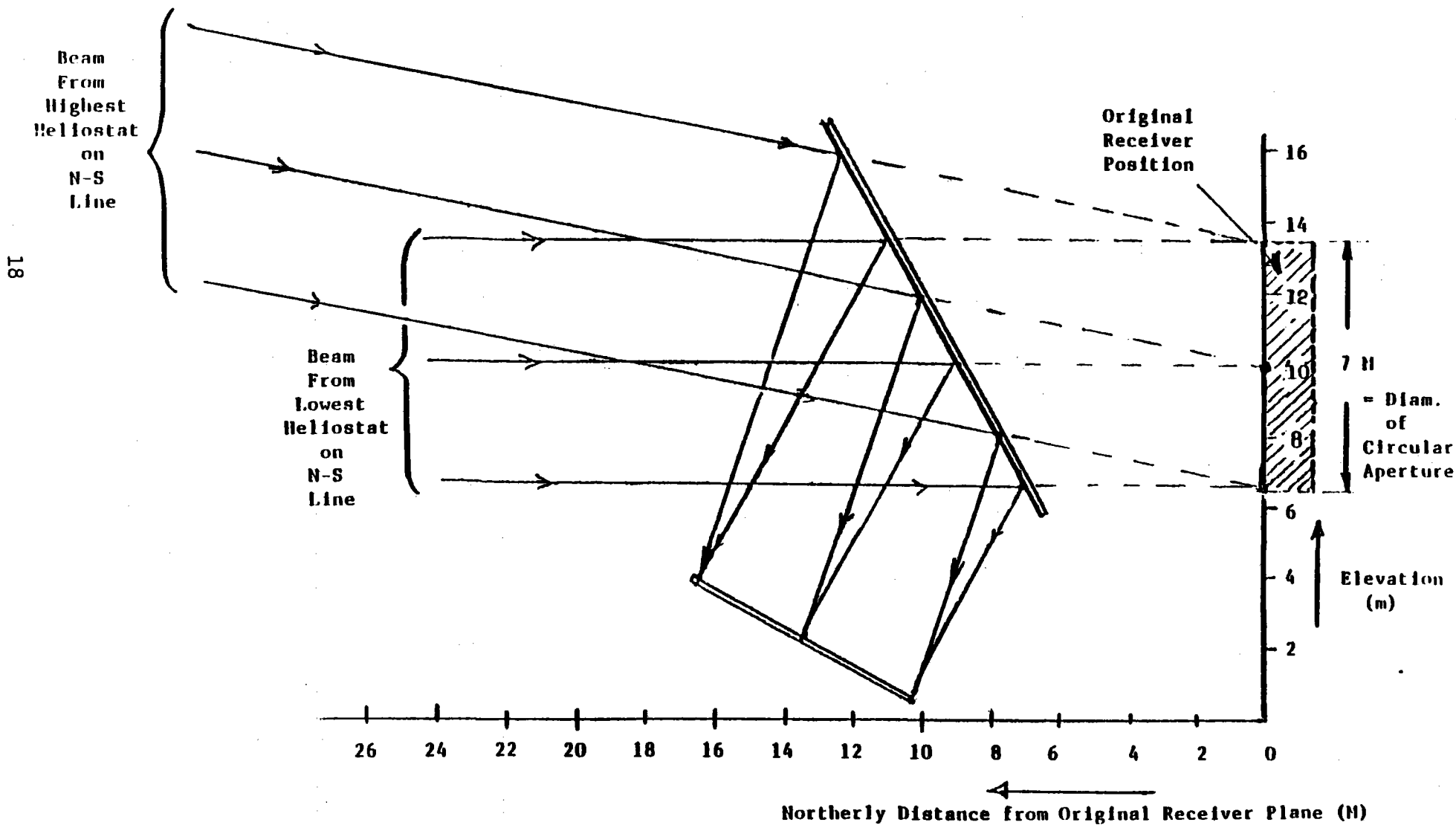

a few square meters in area into one large mirror.

3.1.4 Special Applications

Potential special applications to which the UHA concept appears to lend itself are:

- (1) Processes involving direct absorption of heat by solid or liquid chemicals. Included in this category are chemical manufacturing or refining processes where granular, powder, or liquid materials are exposed in the form of a free-falling "curtain" to very high flux rates for short exposure times.
- (2) Processes in which the receiver coolant is a gas or mixture of gases to be heated to very high temperatures, e.g., in steam reformers.
- (3) Solar furnace applications
- (4) Testing vulnerability of materials or equipment to extremely high flux levels (e.g., simulation of nuclear weapon radiation) over areas of a few square meters.

For the first type, it would be advantageous to have the material to be treated transported across the focal plane on a horizontal flat surface. Figure 11 shows how that might be achieved with the use of a 45° secondary mirror and a conveyor belt.

For the second type, an example is the solar repowering design for the Valley Nitrogen Producers, Inc. Ammonia Plant in El Centro, CA. (Reference E), which is included in DOE's FY 81 Repowering program studies. In this design, an internal cavity receiver is employed to collect the heat energy by flowing a gas mixture through catalyst-filled metal tubes in the receiver. A chemical reaction takes place in the tubes at temperatures approaching 1500° F. In

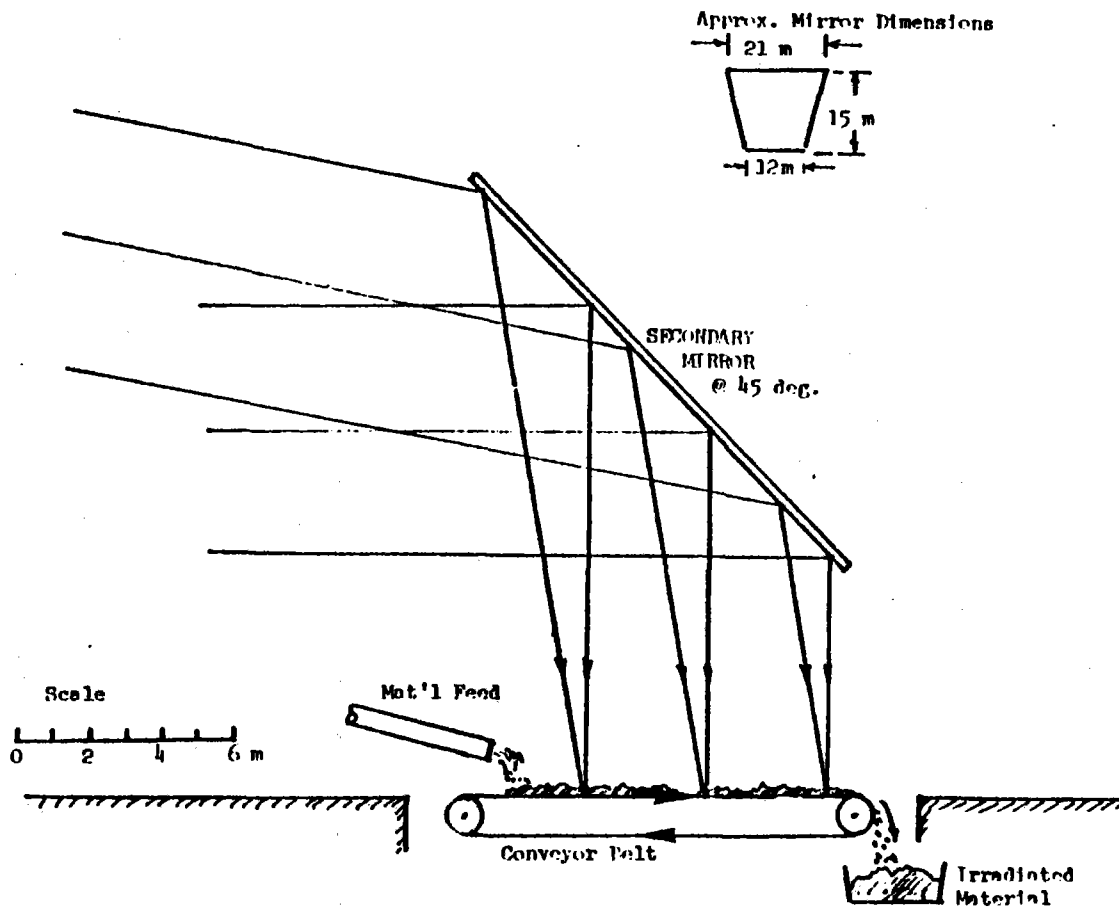

Figure 11. Concept for Direct Absorption Application of UHA (25 MW_t Scale)

this application, having the cavity receiver close to ground level would be an advantage, and no secondary mirror would be required.

The plant design described in Reference E uses a conventional north field heliostat array totaling 58,864 m² of mirror area and utilizes an elliptical receiver aperture only 33 m² in area. A preheated mixture of steam and natural gas enters the receiver tubing system at a temperature of 500°F and exits at 1450°F. The peak solar-derived power supplied by the receiver is 27.1 MW_t.

For the third type (solar furnace applications), it is likely that the secondary mirror would not be needed. There would be distinct advantages in having the specimens to be irradiated at near ground level, even inside a building, instead of on top of a tower. Not only is there an advantage in mechanical convenience, but desired wind conditions and/or specialized gaseous atmospheres around the irradiated material can be provided. A black body cavity type furnace can be used to conserve and concentrate the energy in a confined volume for hours at a time, if desired, because even though the redirected solar radiation arrives at the UHA receiver plane in a rather large solid angle (about one quarter of a steradian), it can be introduced into a cavity through a circular opening of relatively small diameter.

In the fourth listed application the UHA configuration at the energy utilization point offers distinct advantages in adaptability to differing target configurations over the power tower approach, and annual collection capability is not a strong consideration.

It is concluded that the UHA is generally better suited to the types of special applications briefly addressed here, than is the conventional power tower array. In the industrial manufacturing applications (categories 1 and 2 above), the lower annual collection performance indicated in Figure 6 may be outweighed by optical and mechanical advantages cited in this report.

3.1.5 Beam Safety Aspects

An unavoidable feature of the power tower approach to central receiver designs is the potential eye damage hazard to passengers in low flying aircraft in the vicinity of the collector field created by individual beams when heliostats are being brought into operation from a stowed position, or when an array controller malfunctions. The UHA configuration inherently avoids this problem since the heliostats' regime of movement can be restricted to prevent redirected beams from ever being pointed higher than the receiver level, which would keep them below the normal line of sight for low flying aircraft. The UHA thus offers a clear advantage with respect to beam safety for air traffic. However, unfortunately, there will be a significant hazard to ground observers working in the vicinity of the receiver, and, unless the sides of the field are fenced, to adjacent areas.

3.2 Veda Industrial Heliostat

3.2.1 Optical Design

The VIH design uses a single mirror surface that is a section of a torus, i.e., the radii of curvature are different in the horizontal and vertical axes of the mirror, as illustrated in Figure 12. The heliostat is also pointed by an equatorial mount rather than an altitude-azimuth (altazimuth) mount so that the toric axes are more closely aligned with the sun. This design gives better control of aberrations for off-axis rays, particularly astigmatism, than would be achieved with a spherical mirror surface.

In Veda, Inc. studies which compared a typical Repowering heliostat and the VIH used in a 10 MW_t UHA configuration (Reference A), it was found that the receiver area required for the Repowering heliostat case was from 14% to 21% larger than that required for the same collector field using the VIH with its toroidal segment

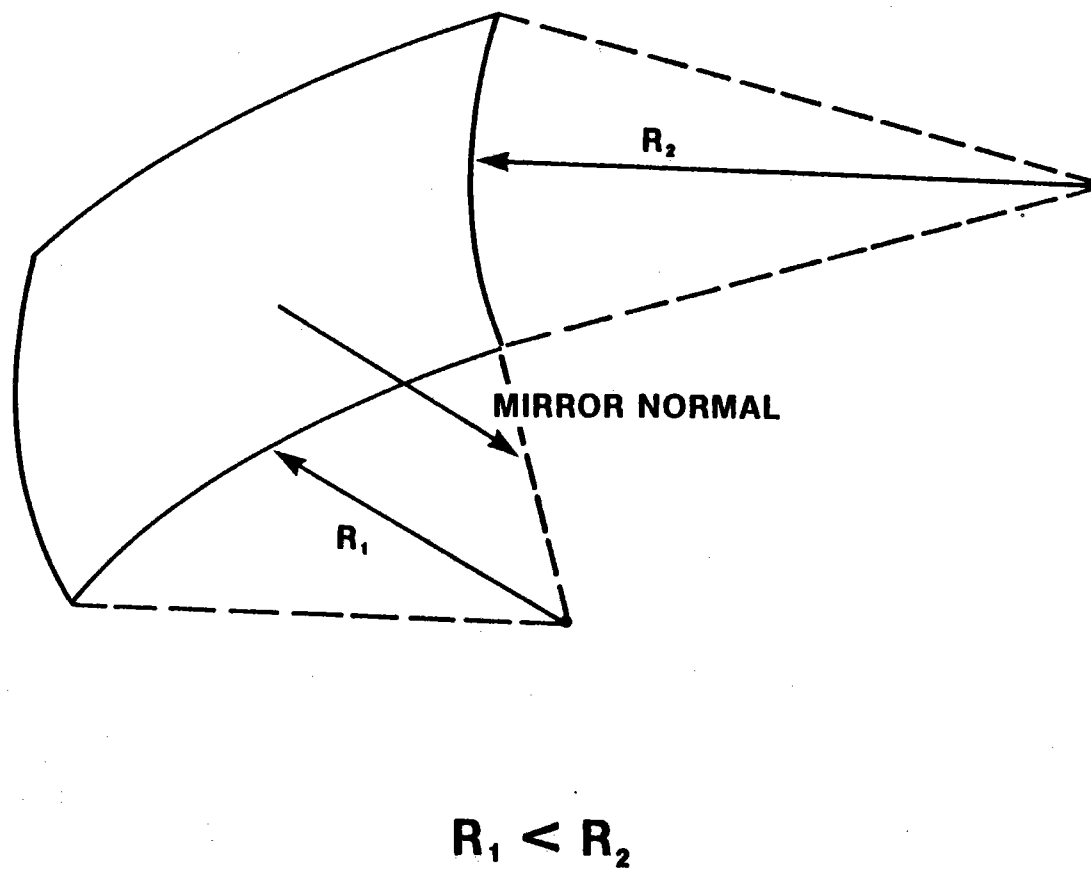

Figure 12. Toroidal Segment Mirror Surface

mirror for the same capture efficiency. These claims appear to be valid; however, a more rigorous ray tracing technique is recommended for such analyses. The Veda analysis divides up the individual heliostat mirrors into only 25 elements in order to compute flux density. Elliptical sun images thus produced are added together. The method apparently does not take into account which part of a mirror is being blocked, however, when blocking and shadowing effects are being treated. As a result, the image quality calculation reported in Reference A may have some inaccuracy. These simplifications in calculation probably do not greatly affect the overall results.

In contrast, the Repowering heliostat, typified by the design selected for use in the Barstow 10 MW_e Pilot Plant, is composed of multiple mirror facets which are rectangular in shape with an approximate 2.8:1 length-to-width ratio. The facets can be individually prefocused by "warping" along a preferred axis, and the mirrors are individually tilted or "canted" so the centroid of the projected beam from each mirror falls along the heliostat aiming axis. This flexibility allows the Repowering heliostat designer to reduce aberrations by imposing a cylindrical curvature along either axis of the mirror facets by selectively canting the mirror modules. Thus, it is possible to minimize the optical aberrations in the Repowering heliostat for a time of day selected such that performance degradation during the remainder of the day will be minimized. However, even when those steps are taken it is prevented from complete optical duplication of a toroid. The fact that the VIH mirror is closer to a toroid (and uses an equatorial mount) means that it can consistently produce a smaller focus spot throughout the collection period. That will be a distinct advantage in many applications.

3.2.2 Equatorial Mount

The equatorial mount used for the VIH is illustrated in Figure 13. The fact that the VIH heliostats are driven equatorially helps keep the toric axes more closely aligned to the plane containing the sun, heliostat, and receiver than could be achieved with an altazimuth mount. Figure 14 shows the alignment in a geocentric (equatorial) coordinate system with the heliostat at the center. For a certain time of the year the sun maintains a fixed declination given by DCL_S , and moves across the sky during the day with a constantly changing hour angle, HA_S , relative to the meridian. The receiver maintains a constant position in the coordinate system, given by HA_R and DCL_R . Shown in Figure 14 is the direction to the receiver from a heliostat in the center of the array at the same height as the receiver ($HA_R = 0$, $DCL_R = 0$). The required pointing direction of the mirror normal is halfway between the sun and receiver and is given by:

$$HA_M = 1/2 (HA_S + HA_R)$$

$$DCL_M = 1/2 (DCL_S + DCL_R)$$

As the earth rotates, the sun can be tracked by rotating the heliostat about the polar axis, keeping the DCL_M constant. The declination axis coincides with the horizontal toric axis, and the vertical toric axis is tilted depending on the sun and receiver declinations. It can be visualized from the figure that the toric axes remain in a better, though not exactly correct, relationship to the sun-receiver plane than they would have on an altazimuth mount which rotates the mirror about the zenith-horizon coordinate system. Thus, the equatorial mount controls aberrations better throughout the day than does the altazimuth mount. Ideally, the vertical toric axis should be in the plane of the sun and receiver, but that condition occurs only at high noon. It should be noted

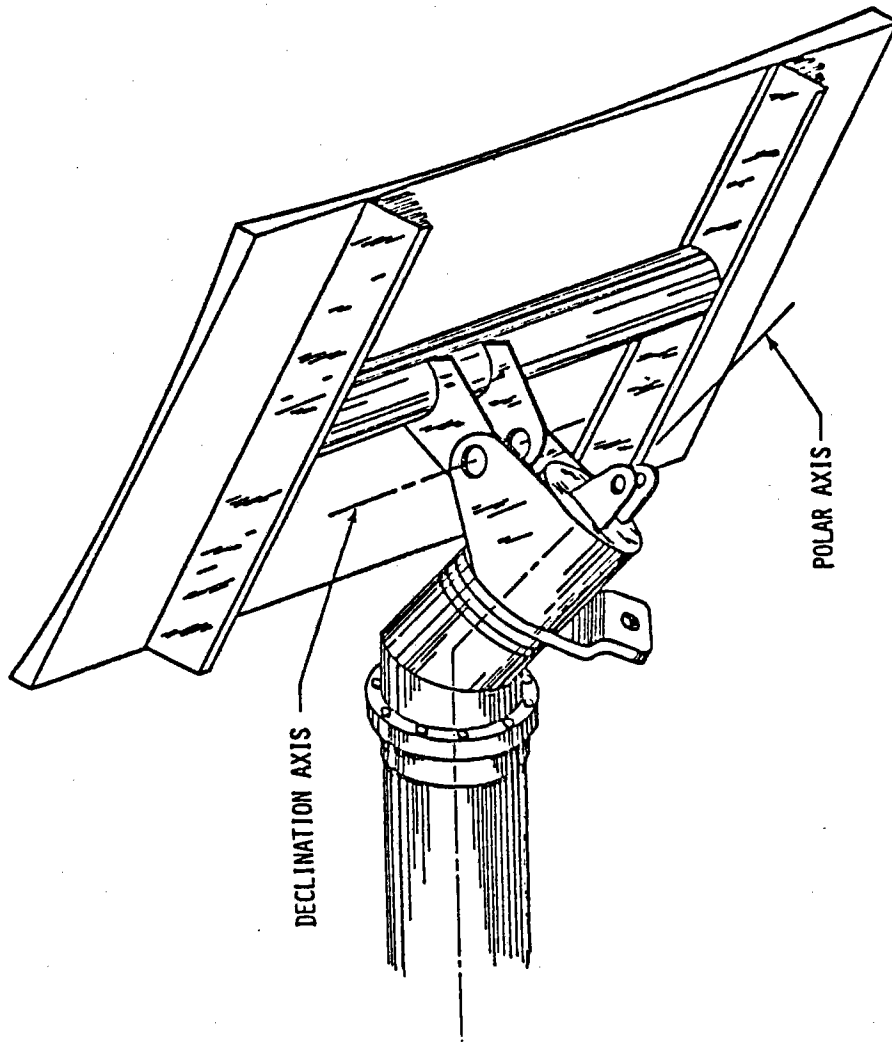

Figure 13 - Veda Industrial Heliostat

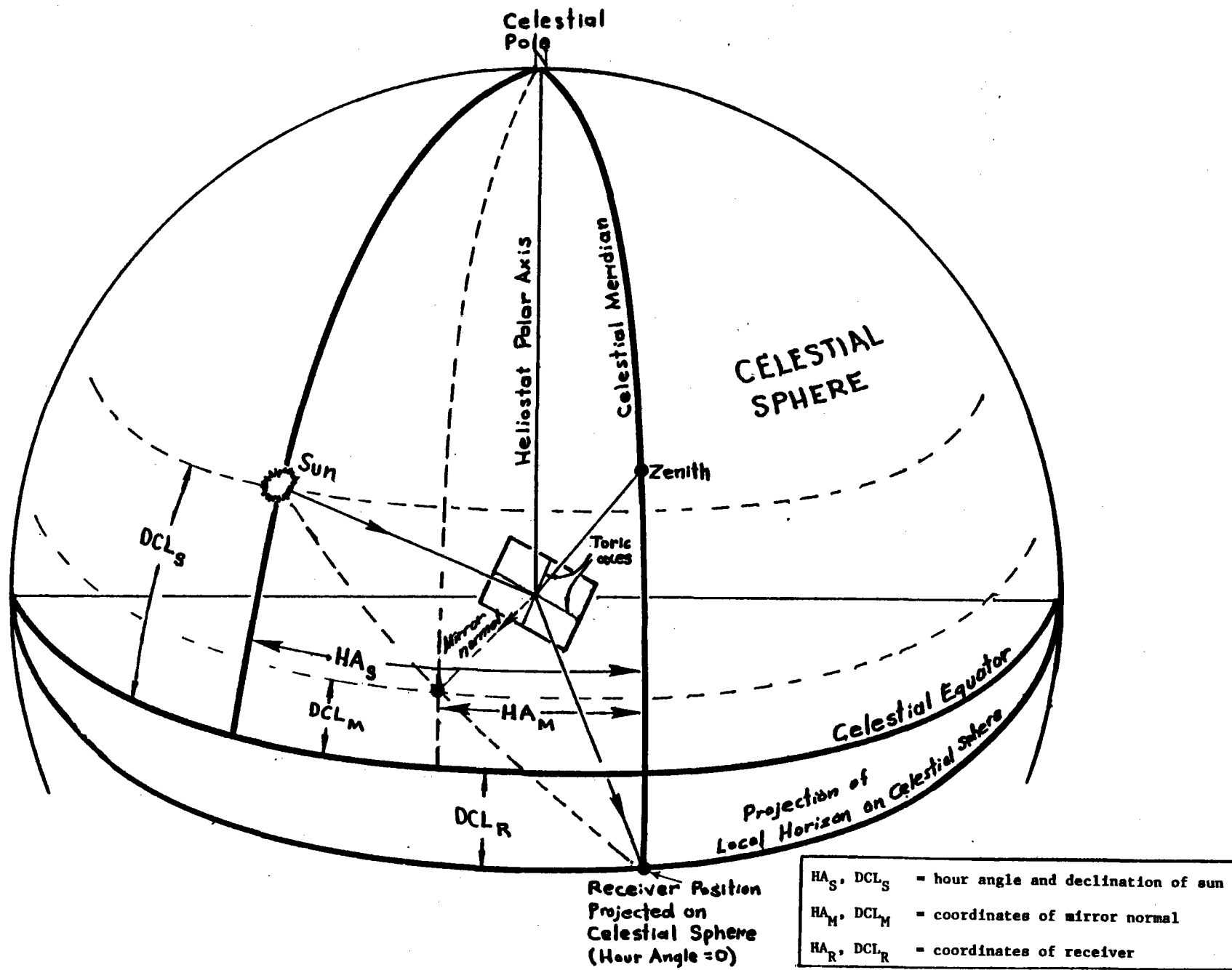

Figure 14. Geocentric Coordinate System and Mirror Positioning

that there would be no advantage in terms of astigmatism correction in driving a spherical mirror equatorially since it has a uniform radius of curvature.

The baseline VIH mirror is only 2 m x 3 m in dimension (relatively light in weight) which lends itself to the mounting configuration shown in Figure 14. For Repowering heliostats, typically 8 to 10 times greater in mirror area, such a mounting configuration would be difficult and expensive from a fabrication standpoint, and in Veda's analysis treating a 49 m² Repowering heliostat in the UHA configuration they have assumed the use of the conventional vertical post and altitude-azimuth mounting (page 5-20, Reference A).

In summary, it is concluded that the equatorial mount is ideal for the baseline 6 m² Veda heliostat employed in the UHA, and is preferred over an altazimuth mount, since pointing the Veda heliostat with an altazimuth mount would not take advantage of its optical design for reducing aberrations.

3.2.3 Manufacturability

The much smaller size of the VIH would suggest much easier manufacturing than is the case for a typical second generation Repowering heliostat. However, the fact that two different radii must be imposed on the reflective surface appears to call for a manufacturing process that would form the mirror to fit a mold, and all mirrors would have the same shape. Once the toroidal segment molds are made to the proper configuration the process would lend itself to mass production. The image quality, and thus mirror figure control in manufacturing, is not highly critical in this application, so there would not be any substantive improvement in optical performance even if such a mirror was tailor-made. Neither detailed manufacturing feasibility nor comparative costs of manufacture with Repowering heliostats has been explored in this

analysis, however, so no supportable conclusions can be drawn in that area without further investigation.

4 SUMMARY OF EVALUATION

The results of this brief evaluation can be summarized for the UHA and the VIH by listing the strong and weak points for each. These are presented below.

4.1 UHA

Strong Points

- (1) Higher net power collected per square meter of mirror area than with power tower systems (estimated to be from 10 to 25% more).
- (2) Higher average flux density and smaller dimensions of receiver aperture than with power tower systems of equal collector surface area.
- (3) Relatively flat flux profile and correspondingly lower edge losses for a given power level.
- (4) Higher peak temperature levels are achievable than with a power tower array having the same mirror area.
- (5) Because of the unique UHA geometry, the collected energy can be conveniently applied:
 - in receivers at or near ground level (eliminates tower costs)
 - in direct absorption processes

- in high temperature cavity receivers
 - in solar furnace applications
 - testing vulnerability of materials to extremely high radiation "flashes"
- (6) The beam safety problem with respect to low flying aircraft is non-existent.
- (7) Structure cost estimates are very conservative and would be reduced by making UHA and receiver integral with buildings in site-specific industrial applications.

Weak Points

- (1) Has lower overall heliostat area efficiency (on an integrated annual basis, as much as 11% lower) than with power tower array.
- (2) Cost of supporting structure designed solely for heliostats may be excessive for very high power arrays ($>25 \text{ MW}_t$).
- (3) Potential beam safety problem for workers in vicinity of receiver and outside the field.
- (4) Usable portion of the solar day is lower in summer than with horizontal power tower arrays.

4.2 VIH

Strong Points

- (1) Produces much higher and more uniform average flux density, with less spillage at the edges of the receiver aperture.

- (2) Optical design minimizes astigmatic aberrations better throughout the day than does a Repowering heliostat.
- (3) Equatorial mount contributes substantially to the control of image aberrations.

Weak Points

- (1) Anticipated higher initial tooling costs per square meter of mirror surface, due to compound radii requirement, than for conventional Repowering heliostats.

5. RECOMMENDATIONS

On balance, it is believed that the UHA concept, using either the VIH or conventional Repowering heliostats offers enough advantages for industrial applications that it warrants more detailed investigations to validate the analyses and results presented here. It will not likely be a strong competitor to the power tower array for utility applications unless it turns out that beam safety for air traffic, etc. becomes a troublesome issue in gaining acceptance of solar thermal central receivers at some sites.

The VIH concept enhances the UHA performance and may be enough to offset the impact of reduced heliostat area efficiency much of the year which is inherent in the UHA geometry. Its development costs and production techniques require investigation by persons with commercial/industrial component manufacturing expertise.

Blocking and shadowing effects should be included in a more rigorous ray tracing analysis, and heliostat area efficiencies for all solstice and equinox conditions should be calculated for 5, 10, and 25 MW_t field sizes for a given latitude, e.g., Barstow or Albuquerque.

The UHA is particularly well suited for extremely high radiation flux testing applications. The prospect of a very high level uniform flux,

sustained for periods of up to a few hours, is particularly attractive in this regard.

As a final recommendation, site-specific application of the UHA concept in Industrial Process Heat (IPH) processes and direct absorption processes; e.g., ore refining and oil shale retorting should be explored, and a UHA system to perform, say, the Valley Nitrogen Producers Ammonia Plant solar retrofit function should be sized and costed for direct comparison with the conventional heliostat array already designed for that application.

If the above recommendations are carried out, it is believed that DOE will have a firm data base on which to decide on a future course of action with respect to the concepts proposed by Veda, Inc.

6. REFERENCES

- A. "Economic Analysis of the Unified Heliostat Array", Veda, Inc. Final Report, DOE/SF/10802-1, January 1981.
- B. "Central Receiver Solar Thermal Power System", Phase 1: Preliminary Design Report, Vol. 3, Collector Subsystem, Martin Marietta-Aerospace, April 1977 SAN/1110-77-2 (Vol. 3).
- C. "Robins Air Force Base Solar Cogeneration Facility Topical Report", April 1981, Contract No. DE-AC03-81LSF 11494, Westinghouse Electric Corp.
- D. "Phase I of the First Small Power System Experiment (EE No. 1)" Final Technical Report, Vol. 5, McDonnell Douglas Corp., May 1979.
- E. "Solar Central Receiver Reformer System for Ammonia Plants", Final Report, Executive Summary, PFR Engineering Systems, Inc., July 1980. DOE/SF/10735-1 (ES).

7. APPENDIX

Secondary Redirecting Mirror Analysis

Since the solar image formed by the Veda heliostat array is formed in an almost vertical plane, a secondary mirror may be necessary to redirect the image to a horizontal position when the material to be heated cannot be transported in a vertical position. The important considerations for this mirror are surface reflectivity, size required, energy absorbed, and surface flatness.

The surface reflectivity will control the amount of energy lost through absorption by the secondary mirror and the heating effect on the secondary. Figure A-1 shows the reflectivity of surface films of silver and aluminum, which have values of 0.98 and 0.91, respectively, at 0.5 microns. Silver has a high reflectivity but will require an overcoating to prevent tarnishing. Aluminum is the most common material used for mirrors and is usually coated for better abrasion resistance. Silver has poorer adhesion to glass, but if a metal mirror is used for better heat dissipation, this is probably irrelevant. Considering that high reflectivity is most important to minimize energy loss and secondary heating, overcoated silver would seem to be the best choice but investigations would have to be made on surface adhesion, deterioration of coating and reflectivity, and thermal characteristics. It should be noted that since the secondary is one-of-a-kind and very important in contributing to performance, much more care can be taken in its manufacture and maintenance. On the other hand, since a considerable degree of protection from the environment can be provided by the receiver housing the physical requirements on the overcoating can be less stringent.

Figure A-2 shows the geometry of the heliostat, secondary and image. Table A-1 presents calculations of spot size on the secondary for the 1 MW and 10 MW systems. For 1 MW system with a secondary mirror 3 m from

Figure A-1 Reflectance of Metal Surfaces

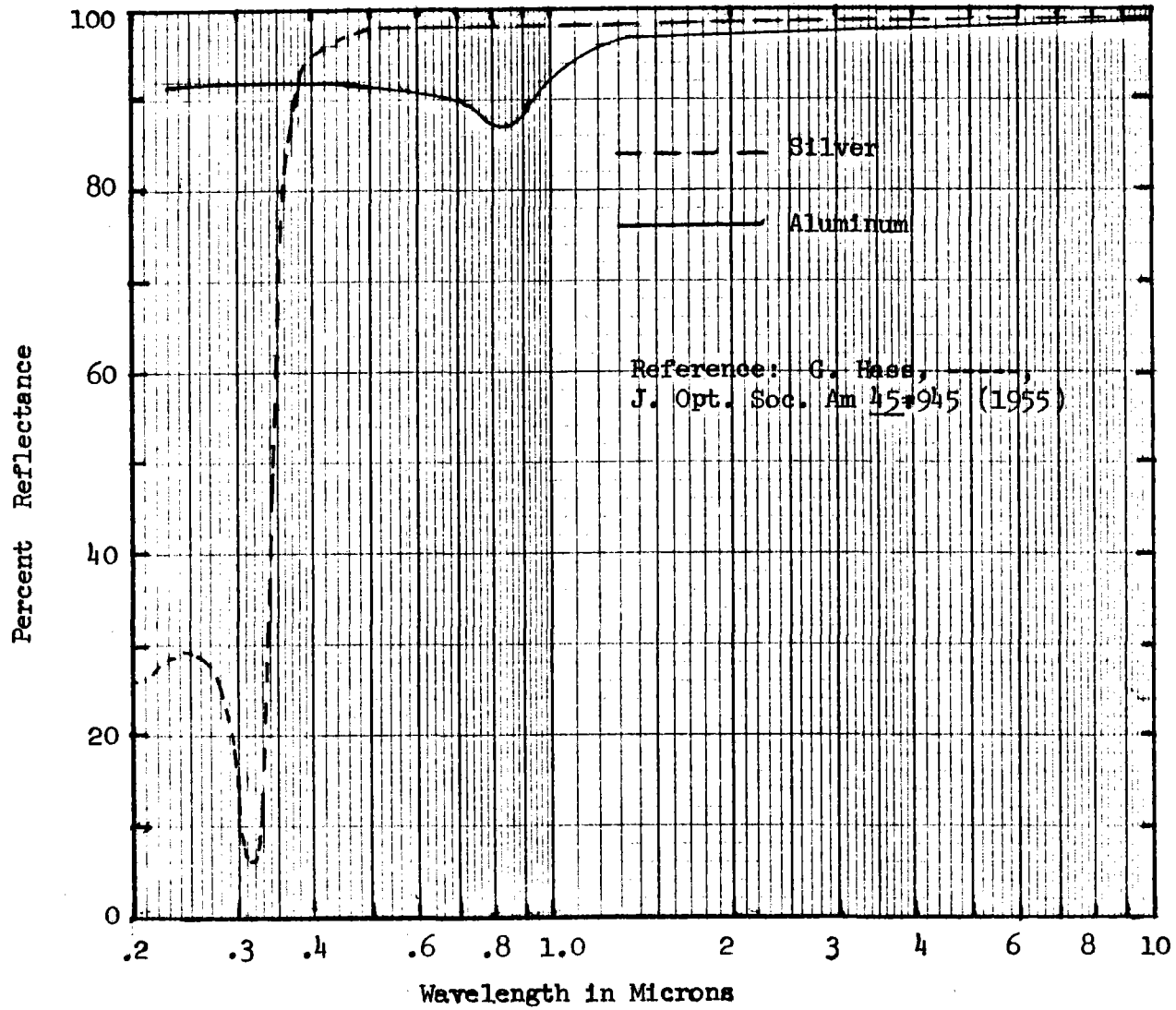
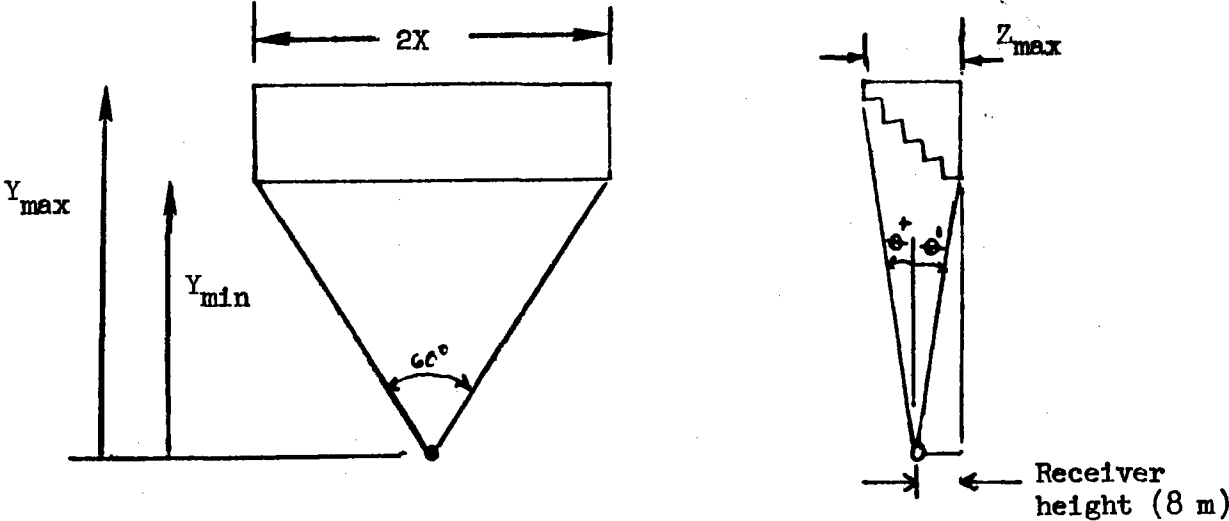

Figure A-2 Secondary Mirror Geometry



36

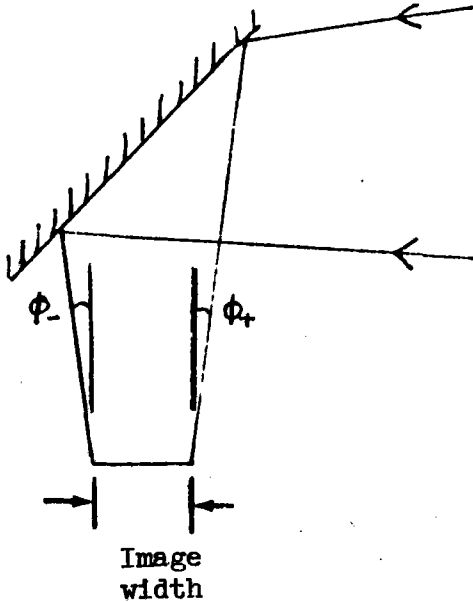

Table A-1

SECONDARY MIRROR ENERGY CALCULATIONS

1 MW System

$X = \pm 52.5 \text{ m}$

$Y = 100 \text{ m avg}$

$Z_{\text{max}} = 22 \text{ m}$

rect ht = 8 m

horizontal beam angle = $\pm 30^\circ$

vertical beam angle = $\pm 6.1^\circ$ about -1.1°

Image diam $\sim 1 \text{ m}$

On Secondary horiz. width $1 + 2.46 = 3.46 \text{ m}$
 vert. width $1 + 0.64\sqrt{2} = 2.32 \text{ m}$

For distance of 3 m from solar image:

Area of solar image $\pi(0.5)^2 = 0.785 \text{ m}^2$

Area of second. spot $\pi/4(2.32)(3.46) = 6.3 \text{ m}^2$

or 8:1

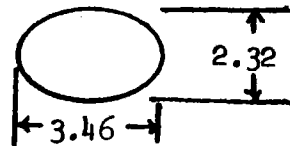

For 1 MW/m^2 peak image energy density:

We get 0.125 MW/m^2 on secondary

98% reflected, 2% (2.5 kW/m^2) absorbed

91% reflected, 9% (11.2 kW/m^2) absorbed

10 MW System

$X = \pm 170 \text{ m}$

$Y = 325 \text{ m avg}$

$Z_{\text{max}} = 68.2 \text{ m}$

horizontal beam angle = $\pm 30^\circ$

vertical beam angle = $\pm 5.6^\circ$

image diam 2.93 m

Secondary spot 8.7 x 5.53 m

Area of solar image = 6.74 m^2

Area of second. spot = 37.8 m^2 | 5.6: 1

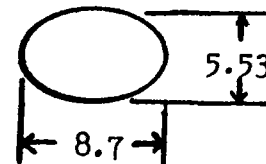

For 1 MW/m^2 in image, we get 0.18 MW/m^2 on secondary

98% reflected, 2% (3.6 kW/m^2) absorbed

91% reflected, 9% (16.2 kW/m^2) absorbed

the image, the spot on the mirror will be a 2.32 x 3.46 m ellipse, giving an 8:1 increase in area and reduction in peak energy density from the image.

With a peak of 1 MW/m^2 in the image, the peak power incident on the mirror will be 125 kW, and a 98% reflecting 2% absorbing mirror will need to dissipate 2.5 kW/m^2 at the center. An aluminum mirror, 91% reflecting and 9% absorbing, will need to dissipate 11.2 kW at the peak. The corresponding values for the 10 MW system are: 5.5 x 8.7 m spot size, 0.18 MW/m^2 max energy density, and peak absorption of 3.6 kW/m^2 for silver and 16 kW/m^2 for aluminum. It should be possible to dissipate this heat using a metal mirror with fins and possibly forced air cooling.

The surface flatness requirements are not very stringent for the secondary mirror since it is close to the image and a small amount of image spread can be tolerated. If the solar image spreads by 4% in a linear dimension there will be a corresponding 8% increase in image area and thus 8% decrease in peak energy density. For the 10 MW system with a 3 m image width, and a secondary 10 m away, this corresponds to ± 20 mrad beam divergence or ± 10 mrad surface roughness tolerance. With such a large tolerance, thermal expansion of the secondary should not cause much of a problem. The surface reflectivity and cleanliness of the secondary are more important than its flatness.