

note

DOE/NASA/0032-28
NASA CR-175106
MTI86ASE58SRI

Automotive Stirling Engine

Mod II Design Report

Noel P. Nightingale
Mechanical Technology Incorporated

October 1986

Prepared for
NATIONAL AERONAUTICS AND SPACE ADMINISTRATION
Lewis Research Center
Under Contract DEN 3-32

for

U.S. DEPARTMENT OF ENERGY
Conservation and Renewable Energy
Office of Vehicle and Engine R&D

DISCLAIMER

This report was prepared as an account of work sponsored by an agency of the United States Government. Neither the United States Government nor any agency thereof, nor any of their employees, makes any warranty, express or implied, or assumes any legal liability or responsibility for the accuracy, completeness, or usefulness of any information, apparatus, product, or process disclosed, or represents that its use would not infringe privately owned rights. Reference herein to any specific commercial product, process, or service by trade name, trademark, manufacturer, or otherwise, does not necessarily constitute or imply its endorsement, recommendation, or favoring by the United States Government or any agency thereof. The views and opinions of authors expressed herein do not necessarily state or reflect those of the United States Government or any agency thereof.

Printed in the United States of America

Available from

National Technical Information Service
U.S. Department of Commerce
5285 Port Royal Road
Springfield, VA 22161

NTIS price codes¹

Printed copy: A04
Microfiche copy: A01

¹Codes are used for pricing all publications. The code is determined by the number of pages in the publication. Information pertaining to the pricing codes can be found in the current issues of the following publications, which are generally available in most libraries: *Energy Research Abstracts (ERA)*; *Government Reports Announcements and Index (GRA and I)*; *Scientific and Technical Abstract Reports (STAR)*; and publication, NTIS-PR-360 available from NTIS at the above address.

PREFACE

This report presents the culmination of years of work by many dedicated individuals. It describes an engine that places the United States at the forefront of a new, dynamic technology. The need for this engine was recognized by Congress in the mid-1970s when it sought to protect our nation from the vulnerability of a dependency on a sole type of fuel. An alternative power plant — one with superior efficiency and multifuel capability over existing engines — was envisioned.

The Stirling engine is this alternative.

Invented in the early nineteenth century, the Stirling engine was regarded as a laboratory curiosity and was not taken seriously by the engineering community. What hampered its development? Two reasons are evident. As a heat engine, the Stirling must operate at high temperature, e.g., 700°C (1292°F), and the long-life, high-temperature materials necessary were not available. Second, early Stirling engines were slow-running machines that produced low power and therefore could not compete with the more versatile spark ignition and diesel engines. These reasons are no longer valid, as evidenced by the work described in this report.

In fact, I maintain that Stirling engine technology now contains advancements as rapid and significant as those in microchip technology and that this leap forward will invalidate any existing misconceptions of Stirling in the general technical community.

Although designed for an automotive application, the basic concept of this engine can be used across a broad range of applications. It represents, therefore, not a subtle change in the technology but a watershed achievement.

There will be those who will read this document and smugly whisper that the Stirling engine will never be a practical power plant and that the need for such an engine has disappeared forever. In reply to those readers, I offer the following quote from the U.S. Gas Turbine Committee of the National Academy of Science in 1940: "Even considering the improvement possible . . . the gas turbine could hardly be considered a feasible application to airplanes because of the difficulty in complying with the stringent weight requirements."

Many people helped in the preparation of this report. With great injustice, there is no space here to thank each person individually. My acknowledgment, though, would be incomplete without thanking Dr. Beno Sternlicht, whose vision gave the Automotive Stirling Engine program an identity. I also wish to thank those who made it possible for the work to be performed, including congressional leaders, members of the Department of Energy, and the very competent staff of NASA, particularly at the Lewis Research Center. The engineers and staff at United Stirling AB in Malmö, Sweden, receive my most grateful praise for their patience and guidance in the engine design. Similarly, credit must be given to the engineers at Mechanical Technology Incorporated who devoted endless hours and a great deal of their personal time to this effort. In particular, the engine described herein was conceived mainly by John Corey, to whom we are all indebted for his keen understanding of the Stirling cycle and his practical design talents.

Special mention must be extended to Sharon Valiquette for visualizing the format of this report. Without her unique talents as editor, this report would be just another technical document rambling for hundreds of pages. Finally, the unique graphics are the result of the special talents of Dean Rueckert, to whom I express my thanks.

Noel P. Nightingale
Assistant General Manager
Stirling Engine Systems Division
Mechanical Technology Incorporated

CONTENTS

PREFACE	iii
AUTOMOTIVE STIRLING ENGINE	1
ENGINE DESIGN SUMMARY	5
MOD II STIRLING ENGINE – A SYNOPSIS	
EXTERNAL HEAT SYSTEM	
HOT ENGINE SYSTEM	
COLD ENGINE/DRIVE SYSTEM	
CONTROL SYSTEMS AND AUXILIARIES	
CONCLUSIONS	37
APPENDIX A	38
CHEVROLET CELEBRITY SPECIFICATION	
APPENDIX B	40
MOD II ENGINE SPECIFICATION	
APPENDIX C	41
FUEL ECONOMY AND PERFORMANCE	
CALCULATIONS	
APPENDIX D	42
THE AUTOMOTIVE STIRLING ENGINE	
DEVELOPMENT PROGRAM	
BIBLIOGRAPHY	50

AUTOMOTIVE STIRLING ENGINE

As established in 1978, Title III of Public Law 95-238, the Automotive Propulsion Research and Development Act directed the Secretary of Energy to create new programs and to accelerate existing ones within the Department of Energy (DOE) to ensure the development of advanced automotive engines. The act was based on congressional findings that existing automotive engines failed to meet the nation's long-term goals for energy conservation and environmental protection. Similar congressional findings established that advanced, alternative automotive engines could, given sufficient research and development, meet these goals and offer potential for mass production at a reasonable cost.

To this end, Congress authorized an expanded research and development effort to advance automotive engine technologies such as the Stirling cycle. The intent was to complement and stimulate corresponding efforts in the private sector and, in turn, encourage automotive manufacturers to seriously consider incorporating such technology into their products. The Automotive Stirling Engine (ASE) Development Program evolved from this legislation. The program began at Mechanical Technology Incorporated (MTI) in Latham, New York, in March 1978. Funding was provided by DOE and administration by the National Aeronautics and Space Administration Lewis Research Center (NASA-LeRC), Cleveland, Ohio, under Contract DEN3-32.

The ASE program set out to meet a substantial challenge—the successful integration of a Stirling engine into an automobile with acceptable drivability. At the outset of the program, the main objectives were to develop an automotive Stirling engine and to transfer European Stirling engine technology to the United States. These generic goals have remained constant, as did a program approach focusing on concurrent engine and component development efforts.

The detailed program objectives addressed various facets of engine development. First, the automotive Stirling engine must demonstrate at least a 30% improvement in EPA combined urban/highway fuel economy over a comparable spark ignition engine. Second, the engine must be installed in an American-manufactured car representative of a reasonable portion of the U.S. automotive market. Further, to ensure the most meaningful fuel economy comparison, the acceleration rate of the Stirling-powered vehicle must match that of the spark ignition-powered vehicle, as must the Stirling's drivability in terms of braking, smooth acceleration with no noticeable peaks or lows, and quick accelerator response.

Other engine development efforts addressed emission levels, power train reliability and life, competitive initial and life-cycle costs, and noise and safety characteristics to meet 1984 federal standards. The design and demonstration of an automotive Stirling engine, designated the Mod II, represent the realization of these ASE program goals. The Mod II reflects the advancements made in Stirling technology and specifically addresses those problems that heretofore had prevented the Stirling from achieving widespread acceptance. The Mod II not only fulfills the promise of superior fuel economy but nullifies arguments that Stirling engines are heavy, expensive, unreliable, and demonstrate poor performance.

AUTOMOTIVE STIRLING ENGINE TECHNOLOGY PROGRESSION

	<u>1978</u>	<u>1986</u>
Weight/Power	8.52 kg/kW (14 lb/hp)	3.35 kg/kW (5.5 lb/hp)
Manufacturing Cost*	\$5000+	\$1200
Acceleration 0-97 km/h (0-60 mi/h)	36 s	12.4 s**
Combined Fuel Economy	8.1 km/L (19 mi/gal)	17.5 km/L (41 mi/gal)
Rare Metals	Cobalt	None
Seal Life	100 h	2000+ h

* Based on 300,000 units per year

** 1417-kg (3125-lb) car

The 1985 Chevrolet Celebrity was chosen as the baseline vehicle. This General Motors A-body car has a manual four-speed transmission, a 2.66 drive axle gear ratio, and an EPA inertia test weight of 1361 kg (3000 lb). A front-wheel-drive car, the Celebrity is representative of the majority of cars sold in the United States; the A-body line accounted for 20% of all GM sales in 1984.* Appendix A includes the vehicle specification and Appendix B includes the engine specification.

* Selection of the manual transmission purposely deviated from the popular configuration. The stock gear ratios are better suited to the Stirling application, and the shift schedule could be changed easily and optimized for Stirling engine operation.

The Mod II-powered Celebrity has a predicted combined fuel economy on unleaded gasoline of 17.5 km/L (41 mi/gal) versus 13.2 km/L (31 mi/gal) for the spark ignition-powered Celebrity.

The comparison for the highway and urban mileages is equally impressive. Highway mileage is predicted to be 24.7 km/L (58 mi/gal) for the Mod II versus 17.1 km/L (40 mi/gal) for the spark ignition engine; urban mileage is 14.1 km/L (33 mi/gal) versus 11.1 km/L (26 mi/gal). Confidence for these Mod II predictions is based on experience to date with the earlier generation Stirling engines used in the program.

The Celebrity is a highly efficient vehicle, with a fuel economy well above the fleet average for U.S. automobiles. Thus, the Mod II predicted fuel economy is not only 32% above that of the Celebrity but also 50% above the fleet average.

Comparisons of fuel economy should not be made, however, without a simultaneous comparison of vehicle performance, a factor that, until recently, has impeded the Stirling engine from competing with spark ignition engines. Earlier Stirling engines were heavy and exhibited poor transient characteristics as compared with their maximum power levels. One standard used by the automotive industry to compare performance is the time required to accelerate from stop to 97 km/h (60 mi/h). Currently, the Mod II provides very competitive performance for the Celebrity, with a projected acceleration time of 12.4 seconds. This is as compared with 13.0 seconds for the spark ignition-powered Celebrity and 15.0 seconds for the generally accepted industry standard. The gradeability of the Celebrity with either engine is 30%. Details on the calculations used to determine the fuel economy and performance of the Mod II are presented in Appendix C.

The Mod II engine is closely matched to the spark ignition engine, having a maximum design speed of 4000 r/min versus 4800 r/min for the spark ignition engine and maximum power of 62.3 kW (83.5 hp) versus 69 kW (92 hp). The Mod II offers superior low-speed torque performance, with a peak torque rating of 212.2 N·m (156.5 ft-lb) at 1000 r/min versus 182 N·m (134 ft-lb) at 2800 r/min for the spark ignition engine.

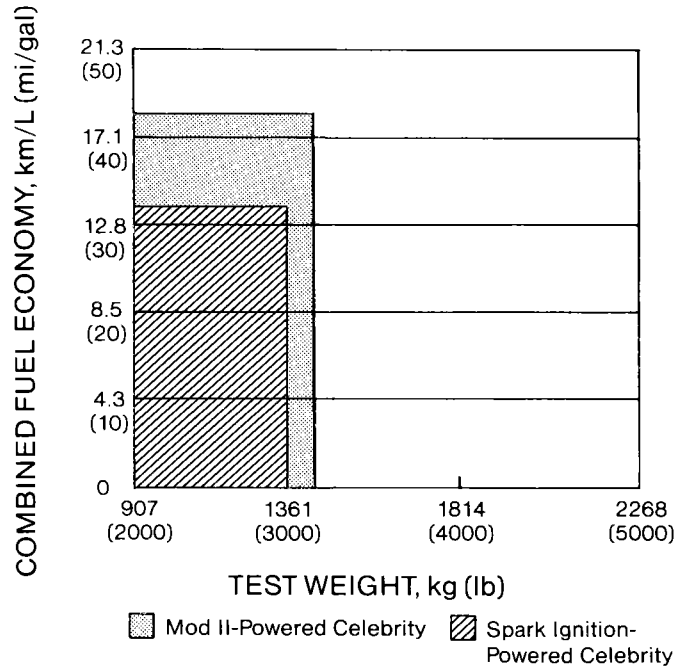

FUEL ECONOMY COMPARISON OF SPARK IGNITION AND STIRLING ENGINES (UNLEADED GASOLINE)

The acceleration of a vehicle is a function of engine torque over the acceleration period. Relative to the spark ignition engine, the Mod II provides quicker acceleration at low engine speeds (due to higher torque) and slower acceleration at high engine speeds (due to lower maximum power and lower torque at maximum power). Integrated over an acceleration period of 0-97 km/h (0-60 mi/h), the total acceleration times of the two engine types are approximately the same.

The Mod II engine is optimized to provide maximum fuel economy in an EPA combined urban/highway driving cycle. The engine average operating condition for this application occurs at a fraction of the maximum power point (1000 r/min, 10 kW (13.4 hp) as opposed to 4000 r/min, 62 kW (83.1 hp)). Technology development during the course of the ASE program has identified the means to tailor the highly efficient engine operating regime to match that of the installation (or application) requirements.

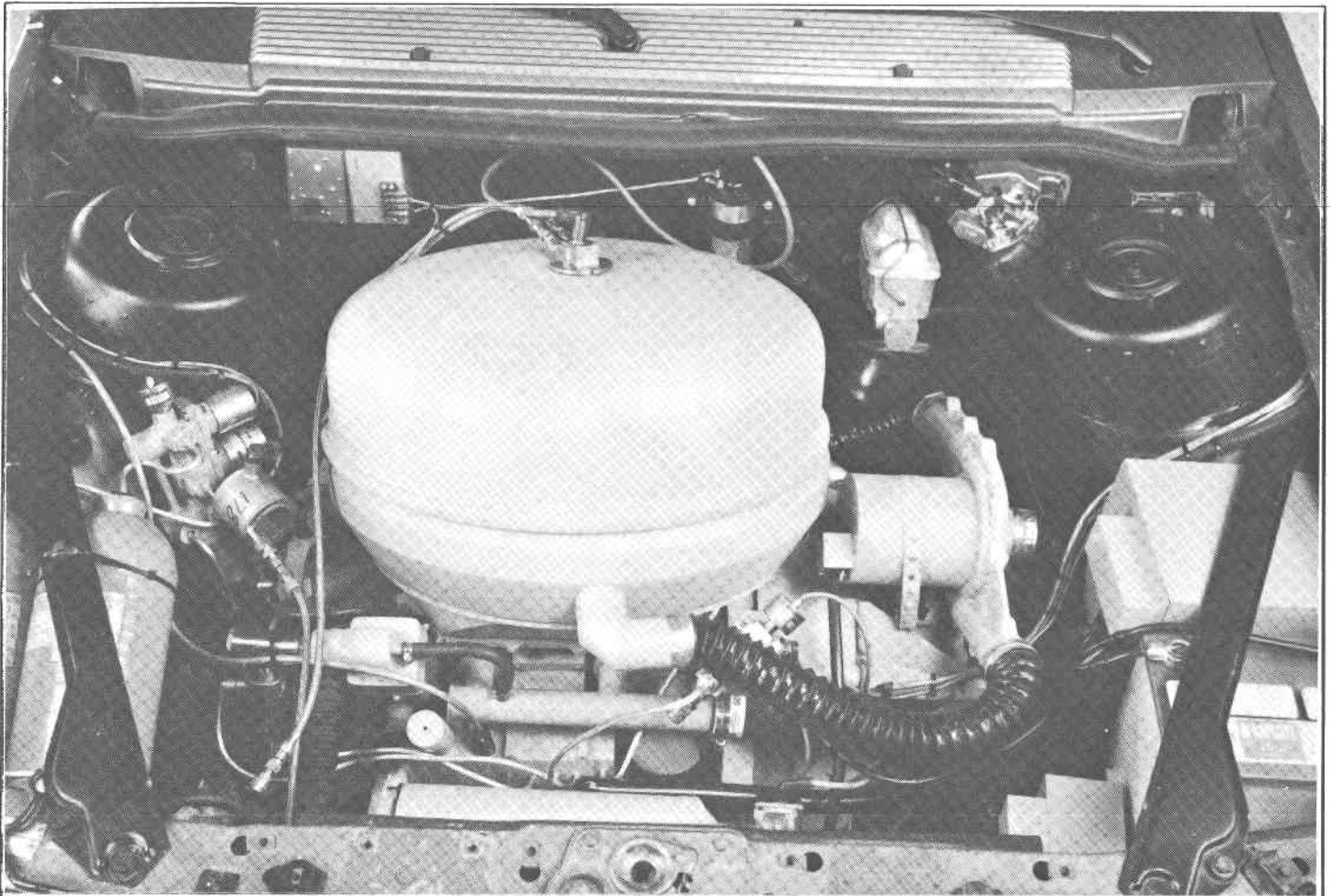

MOD II INSTALLATION IN CELEBRITY ENGINE COMPARTMENT

The Mod II is designed to fit in the same engine compartment as the spark ignition engine, using a stock transaxle. Very few peripheral changes to the frame and compartment are required. This is especially important for a front-wheel-drive car because of the sensitivity of its handling characteristics to suspension and power train mounting geometry. To preclude any such effects, the location of the axle pickup points at the transaxle output are retained. Power train mounting pads also remain in their stock positions to preserve the roll axis and roll stiffness of the original Celebrity assembly.

Some modifications are required to install the engine. The front cross member is relocated for starter clearance, and the bell housing is lowered to meet the Stirling output shaft. Minor modifications accommodate the larger GM stock radiator, a heavy-duty, high-efficiency aluminum unit normally used with a GM 2.8-liter, V-6 spark ignition engine. In addition

to the standard cooling fan mounted on the engine side of the radiator, a second identical fan is mounted in the front of the radiator.

Along with demonstrating a Stirling engine that delivers superior fuel economy and performance, the ASE program accumulated more than 15,000 test hours on Stirling engines. Such testing has yielded valuable information on the life and reliability of various engine components, as well as data on the formation of emissions and soot during transient operations such as engine start-up and vehicle acceleration. Further, the specific weight of the Stirling engine has been reduced from 8.52 kg/kW (14 lb/hp) to 3.35 kg/kW (5.5 lb/hp), while the cost of manufacturing has been reduced from \$125/kW (\$93/hp) to \$20/kW (\$15/hp).

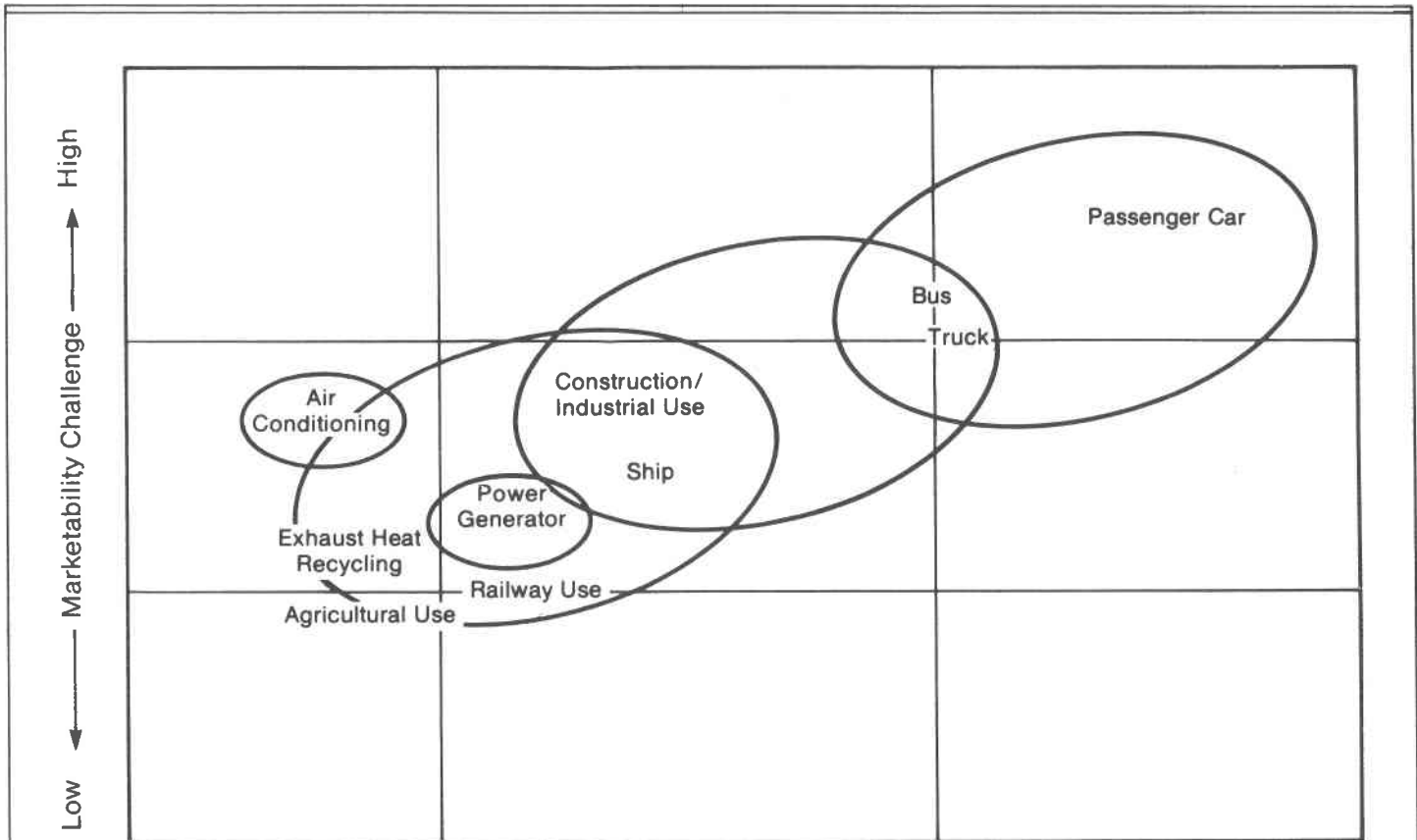

← Low
Manufacturability Challenge
→ High

STIRLING ENGINE PRODUCT SPIN-OFFS

Through achievement of the ASE program goals, there are almost immediate benefits to other applications. Examples include light-duty and heavy-duty vehicles, generator sets, irrigation pumps, solar electric units, heat pumps, industrial prime movers, submarines and other marine uses, and farm equipment. Whereas the windfall of Stirling technology to other uses may be a somewhat subjective assessment, it serves to underscore a key national benefit—that the ASE program provided the United States with a core technology having a host of spin-off products. These, in turn, can provide our nation with a greater capability for conserving energy, as well as maintaining the technological leadership in those areas.

ENGINE DESIGN SUMMARY

Power generation in Stirling engines, as in most heat engines, is accomplished by compressing a gas when it is cool and expanding it when it is hot. The Stirling-specific aspects of this process are

- The gas is contained in a continuous closed volume
- The volume is divided into hot and cold regions
- Compression and expansion are accomplished by periodically varying the size of the volume
- Heating and cooling are accomplished by periodically transferring working gas between the hot and cold regions.

As a consequence, the Stirling engine is a "closed cycle" device—it performs the power generation process, cycle after cycle, on the same working gas rather than taking a fresh charge of working gas from a source, processing it, and then expelling it (open cycle). Power generation results from properly phasing the compression-expansion and transfer processes so that most of the gas is in the cold region while compressing and in the hot region while expanding. In the case of the Mod II, the working gas is hydrogen.*

Of necessity, the hot and cold regions of the engine are separated by a transition zone or "regenerator region," and hydrogen passes through this region during the transfer process. In all engines of practical significance, the hot region contains a heater, the cold region contains a cooler, and the regenerator region contains a regenerator matrix. The heater and cooler supply and reject heat from the engine respectively, and the regenerator reduces thermal losses associated with transferring hydrogen from the hot side to the cold side and from the cold side to the hot side. The regenerator accomplishes this by removing and storing thermal energy from the hydrogen as it passes from the hot region to the cold region and returning this energy to the hydrogen as it flows back from the cold region to the hot region. The cold region (or cold side) includes all the cold engine volumes up to the regenerator face including the cooler; the "cold space" encompasses the same volumes excluding the cooler. Similarly, the hot region (or hot side) includes all the engine hot volumes including the heater; the engine "hot space" encompasses the same volumes excluding the heater.

* The Mod II contains approximately 100 g (3.5 oz) of hydrogen, an amount that does not warrant any safety concern since its energy content is equivalent to only 0.47 L (1 pt) of gasoline.

In most practical reductions of the above process, the periodic expansion/compression of the volume and the periodic transfer of hydrogen are accomplished by reciprocating pistons. In particular, the Mod II utilizes two independent piston faces, one in the cold region and one in the hot region, for each of its four cycles. The region of the cold space into which the cold-side piston moves is called the compression space, and the region into which the hot-side piston moves is called the expansion space. The connection between the compression space and the cooler is called the cold connecting duct. A similar connector in the hot space is called the hot connecting duct. Moving the pistons in phase (both move into their respective spaces simultaneously) results in compression/expansion; moving the pistons out of phase (one moves into its space while the other moves out) results in hydrogen transfer. Moving the pistons at an intermediate phase results in a work-producing combination of both processes.

During engine operation, the pistons move periodically in and out of their engine spaces, and the engine proceeds smoothly and periodically through a sequence of engine cycles. As a normal consequence of this process, the engine pressure varies smoothly and periodically—primarily in response to the expansion/compression process, but also in response to thermal effects associated with the transfer process. This periodic variation in engine pressure is referred to as the engine pressure wave. As a result of hydrogen inertia and friction effects, different locations in the engine have slightly differing pressure waves; therefore, pressure wave information always requires a specification of engine location to be complete. The two most common locations for pressure wave specification are the compression space and the expansion space, and the respective pressure waves are referred to as the compression and expansion space pressure waves. The pressure variation at each location is accompanied by a smooth and periodic flow of hydrogen—primarily in response to the transfer process, but also in response to the volume effects associated with the expansion/compression process. The resultant "oscillatory flow" with superimposed pressure variation is inherent to the engine operation and must be considered carefully in the design of each engine component.

Nonideal performance in the engine system is, in all cases, ultimately traceable to either friction losses or heat transfer irreversibilities. It is helpful, however, in

both analyzing and understanding the engine thermodynamics, to describe the losses in terms of "loss mechanisms." The number of loss mechanisms and their exact definitions may vary. The MTI/United Stirling AB loss mechanism classification (along with an indication of the primary cause of irreversibility) is as follows.

Pumping Loss (frictional). Due to the pressure drop resulting from the oscillatory flow of hydrogen through the engine components.

Leakage Loss (frictional). Result of the flow past the engine hydrogen seals, both static and moving.

Mixing Loss (thermal). Result of the thermal mixing of hydrogen elements at different temperatures.

Hysteresis Loss (thermal). Due to periodic heat transfers between the hydrogen and the engine boundaries resulting from the periodic rise and fall of hydrogen pressure. The periodic rise and fall in pressure results in an associated periodic rise and fall in temperature which results in the periodic heat transfers.

Regenerator Reheat Loss (thermal). Result of imperfect heat regeneration as hydrogen is alternately transferred between the hot and cold sides of the engine.

Appendix Gap Loss (thermal). Due to a complex thermal loss that occurs in the region between the piston dome and cylinder wall as a result of the combined effects of piston motion, hydrogen pumping, and periodic temperature variations in the hydrogen due to the engine pressure wave.

Heater ΔT and Cooler ΔT Losses (thermal). Result of the mean temperature drops between these heat exchangers and the hydrogen.

MOD II STIRLING ENGINE — A SYNOPSIS

The Mod II Stirling engine utilizes a four-cylinder V-block design with a single crankshaft and an annular heater head. It develops a maximum power of 62.3 kW (83.5 hp) and has a maximum speed of 4000 r/min. There are three basic engine systems. First, the external heat system converts energy in the fuel to heat flux. Next, the hot engine system contains the hot hydrogen in a closed volume to convert this heat flux to a pressure wave that acts on the pistons. Finally, the cold engine/drive system transfers piston motion to connecting rods and the reciprocating rod motion is converted to rotary motion through a crankshaft. The engine is also equipped with all the controls and auxiliaries necessary for automotive operation.

EXTERNAL HEAT SYSTEM

The external heat system converts the energy in the fuel to heat flux into the closed working cycle. It consists of a preheater, inlet air and exhaust gas manifolds, insulation cover, combustor assembly, fuel nozzle, and flamestone. To maximize fuel economy, this system requires high efficiency combined with a low hot mass to reduce cold-start penalty (see Appendix C for discussion on cold-start penalty).

The air needed for combustion is delivered to the engine combustion chamber from the combustion air blower through two opposing inlet tubes. The inlet air flows through the preheater, where its temperature is increased by heat transferred from the combustion exhaust gas, into a plenum between the insulation cover and the combustor. From there it flows at high speed through ejectors into the combustor mixing tubes, carrying with it part of the combustion gas. In effect, this combustion gas recirculation utilizes air flowing through multiple ejectors to entrain exhaust gas flow, which then flows via a mixing section into the combustion zone. By recirculating exhaust gases through the combustor, flame temperature can be reduced, which, in turn, reduces the amount of nitrogen oxide emissions produced in the combustor.

The air/combustion gas mixture then enters the swirler region of the combustor where air-atomized fuel is injected through the fuel nozzle and ignited. The burning fuel releases heat in the combustor, increasing the gas temperature to a maximum level. This causes the combustion gas to accelerate toward the heater head.

At the heater head, the combustion gas passes through gaps between tubes and fins, transferring heat from the combustion gas to the Stirling cycle through the thin walls of the heater head tubes. After passing the heater, part of the gas mass is recirculated through the combustor mixing tubes, but the majority is forced through the preheater into the exhaust manifold. The exhaust gas temperature is reduced in the preheater as heat is transferred through its walls to the inlet air. The exhaust gas leaves the engine through two opposed outlet tubes that extend into tail pipes. Because the continuous combustion system of a Stirling engine produces such low emissions and is so quiet and clean, the tail pipes do not require any catalytic converter or muffler.

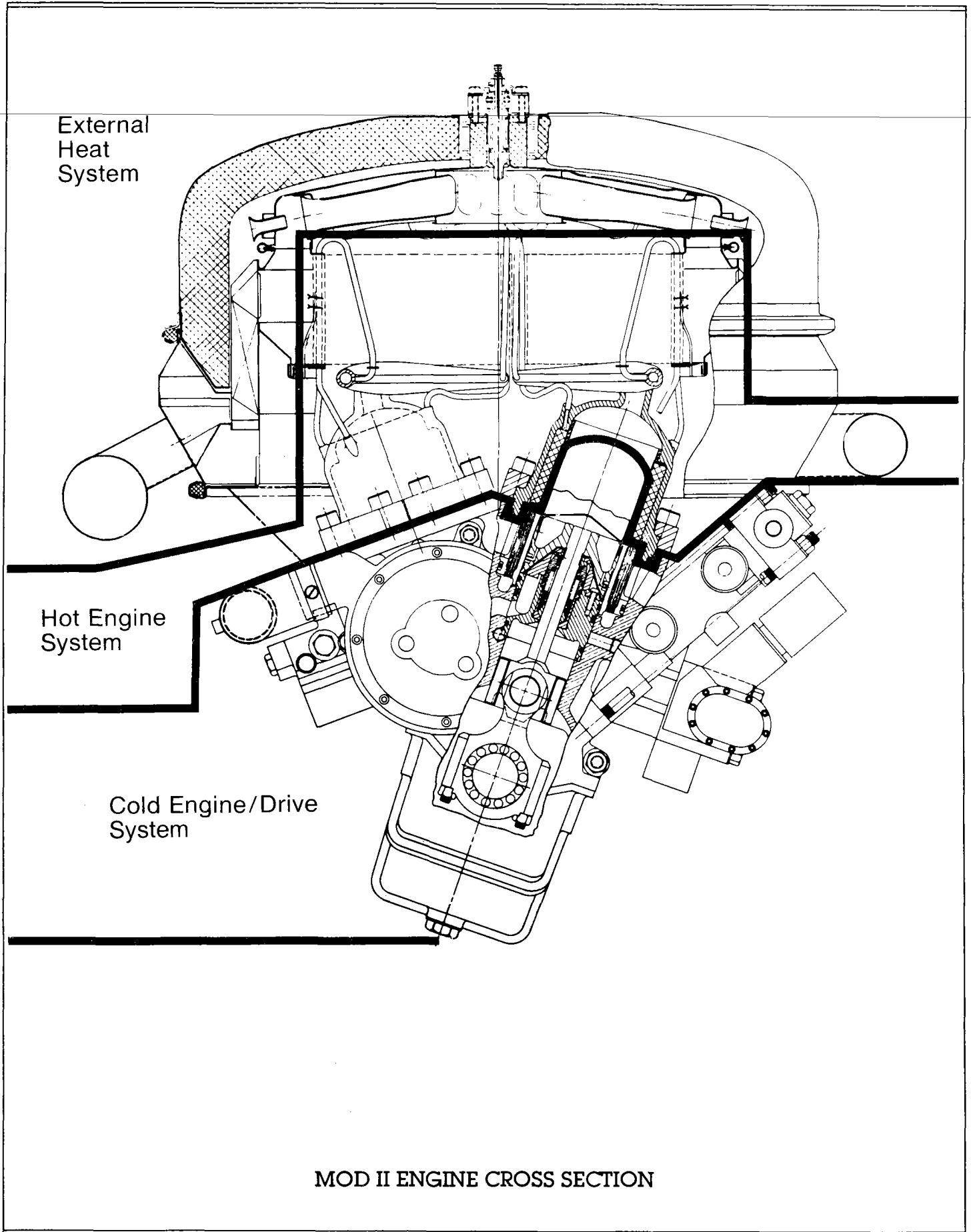

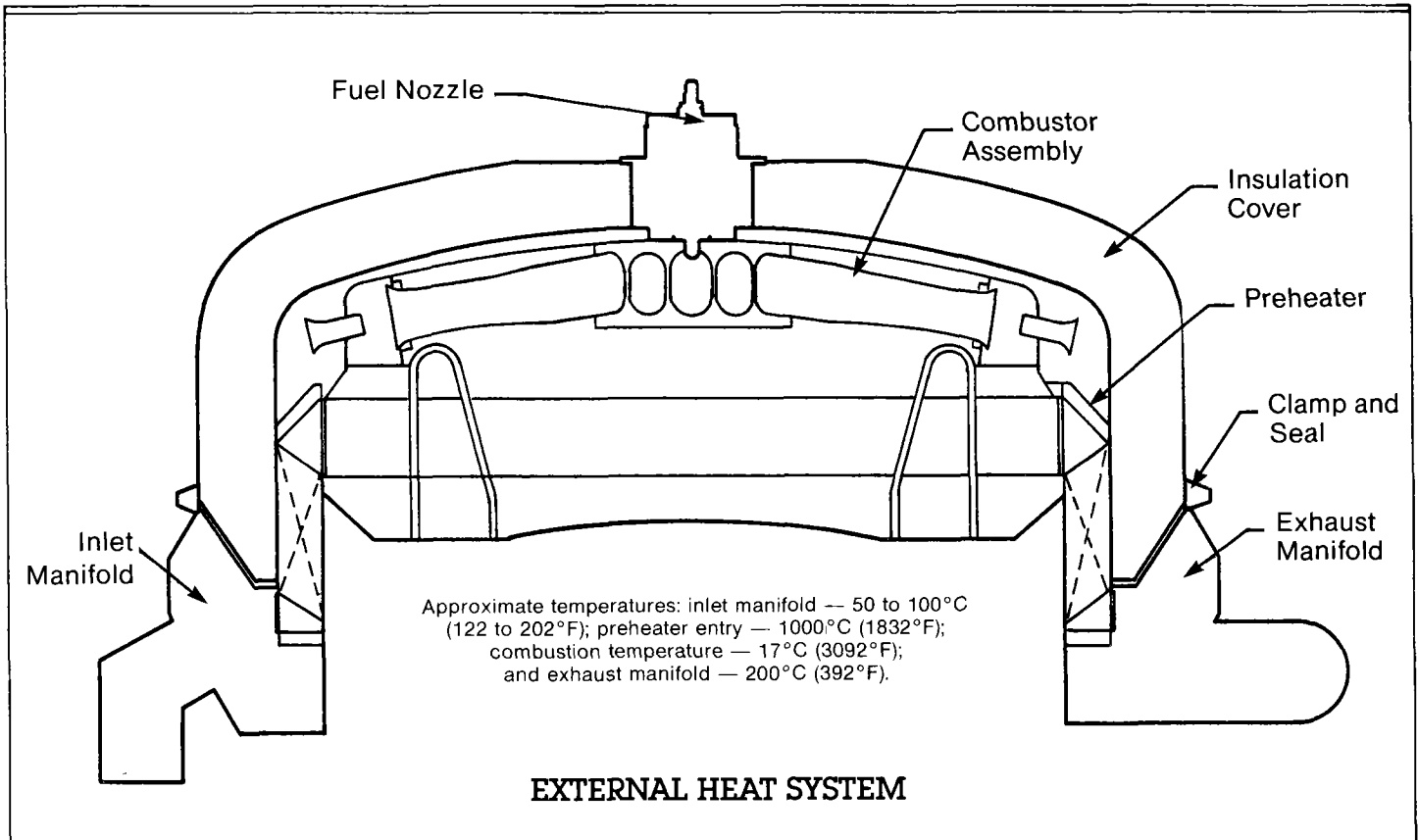

The general specifications and conditions for the external heat system are

Fuel massflow:	0.15 to 5.2 g/s (0.02 to 0.69 lb/min)
Excess air factor:	1.15 to 1.25
Airflow:	2.9 to 86.5 g/s (0.38 to 11.44 lb/min)
Atomizing airflow to fuel nozzle:	0.36 to 0.8 g/s (0.05 to 0.11 lb/min)

Preheater and Inlet Air/Exhaust Gas Manifolds

The preheater matrix is a welded-plate, counterflow heat exchanger with straight-through airflow channels. Exhaust flow enters and exits through cross-headers at right angles to a corrugated part in which true counterflow exists. The plate-to-plate gaps are kept constant in the header sections by small dimples stamped in each plate. These bear against flat areas of the adjacent plates to maintain the required spacing. In the counterflow section, plate spacing is established and maintained by the height of the

corrugations stamped into the plates. These also introduce turbulence in the airflow to enhance heat transfer. The 0.1-mm (3.9-mil) thick plates are made of 253 MA alloy. This stainless steel alloy has constituents to improve high-temperature oxidation resistance.

The preheater matrix is welded between inner and outer circumferential walls and then welded gas tight to the manifold section. The manifold section has a partition that separates an upper exhaust chamber from the lower inlet chamber. Two air inlet tubes and two exhaust outlet tubes connect to the manifolds. These are equally spaced 90° apart, and both inlets and outlets are 180° opposed. The manifolds are designed to maintain a circumferentially even flow distribution through the matrix for both air and exhaust.

Ceramic Preheater

Because the metallic preheater described above has a relatively high manufacturing cost (due to the number of welds required to join the 1000 matrix plates), an alternative ceramic preheater has been designed. This ceramic is a mixed oxide, a proprietary material of Coors Porcelain Company. Although it has a significantly lower manufacturing cost, this preheater has not yet been developed to

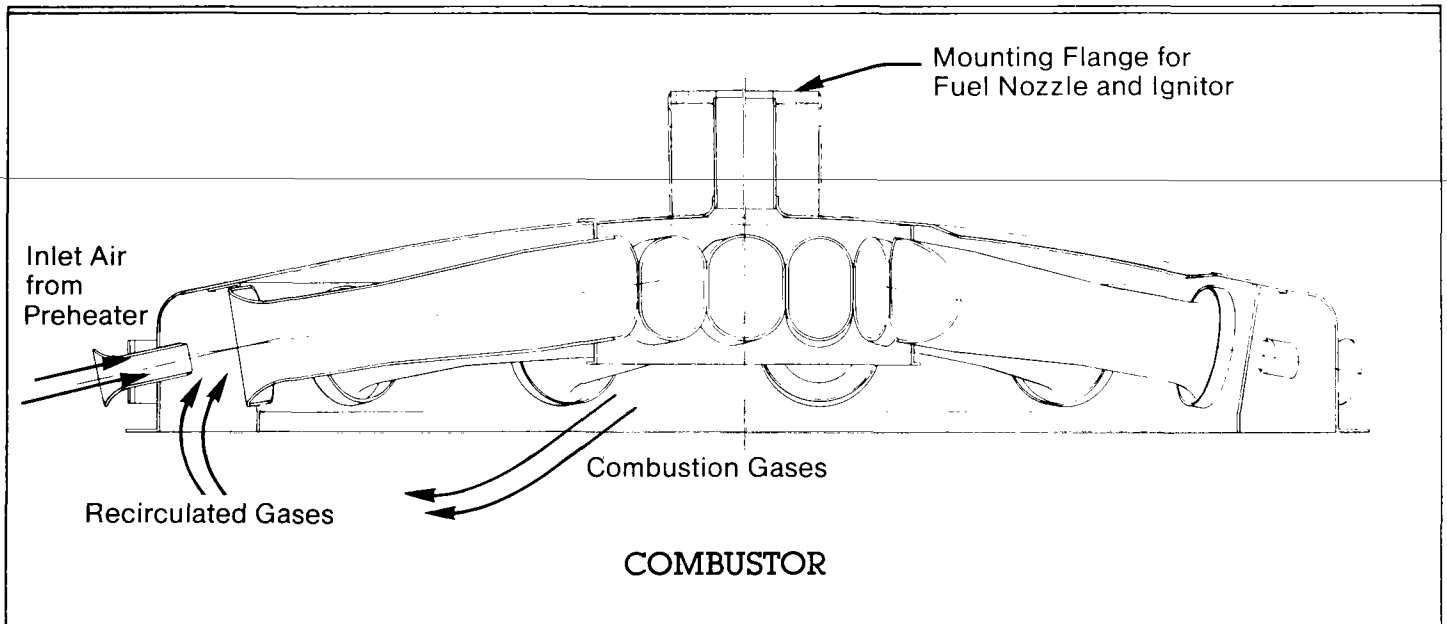

the point where it is reliable. Further development of the ceramic preheater is required to achieve a design and manufacturing process that can consistently deliver a leak-free product. As a heat exchanger, the ceramic preheater performs identically to the metallic preheater so that there is no loss in performance.

Insulation Cover

The insulation cover is made with Triton Kaowool[®] insulation between an outer aluminum casing and a thin, inner stainless steel casing. The cover attaches to the preheater matrix and manifold assemblies with a clamp and seal arrangement.

At its center, the cover is attached and sealed to the combustor and fuel nozzle with a metal bellows, which accommodates the differences in axial thermal growth between combustor and preheater. The combustion gas recirculation system requires a moderately high inlet pressure, and this gives an upward pressure load on the cover that tends to lift the insulation cover and press the combustor cover downward. To add stiffness, the cover has a number of radial corrugations in the outer casing.

Combustor Assembly

Due to the hot environment, stainless steel was selected for all combustor parts. The optimal combustion gas recirculation configuration consists of 12 discrete ejector nozzles in line with 12 radial mixing tubes. These tubes converge near the center of the combustor to form a swirl chamber into which the fuel is sprayed. The mixing tubes are radially fixed at their outer ends and allowed to grow inward through holes in the swirl chamber skirt.

The combustor liner is designed with a spherically shaped shell made from specially textured metal. Radial ribs are formed in the basic shape to give structural support while easing circumferential strains. All these features are designed to prevent buckling of the thin sheet under the severe thermal gradients imposed in service. The mixing-tube locating ring is welded to the liner on its outward edge, to shield the welds from the combustion zone heat.

The outer edge of the combustor liner is clamped to the top flange of the preheater, separating the incoming preheated air at the ejector entries from the exiting combustion gases. Because the heater head grows up thermally more than the preheater, the secondary seal between the mixing-tube ring and the heater tubes is made axially loose, acquiring full seal only at operating temperature. This design preserves alignment between ejector nozzles and mixing tubes without requiring deformation of the combustor liner as in earlier designs.

The combustor neck extends vertically through the center hole in the insulation cover. The fuel nozzle is bolted to the top face of the neck, clamping one

end of the bellows unit, with the other end welded to the inner cover casing. The bellows provides a flexible seal connection that accommodates the relative vertical motion between the combustor top liner and the bottom of the insulation cover. This relative motion is caused by differential thermal growth and also by air pressure acting upward on the insulation cover and downward on the combustor liner. These effects vary with the engine power delivery, due to changes in metal temperatures and air pressure.

Fuel Nozzle

The fuel nozzle is an air-atomizing nozzle with 12 orifices that provide a spray angle of 75°. Atomizing air is supplied internally within the nozzle at a maximum flow rate of 0.8 g/s (0.11 lb/min) and a maximum fuel pressure of 350 kPa (51 psi).

The ignitor is installed in the center of the fuel nozzle. The fuel nozzle itself is mounted in the center of the combustor upper wall, sealed to the insulation cover via the bellows seal.

Flamestone

The flamestone defines the lower wall of the combustor and is located in the center of the ring of heater head tubes to prevent leakage of combustion gases bypassing the heater. Together with the insulation on top of the engine block, it acts as a heat barrier to minimize heat conduction to the cold components.

The flamestone is constructed of a stainless steel frame and post (attached to the engine block) supporting a composite ceramic shield of Triton Kaowool rigidized insulating fibers covered with Nextel™ fabric to prevent erosion. The convex surface of the flamestone sits just above the heater head tube-to-manifold brazed joints, shielding them from direct combustion gas flow to ease thermal stress during the engine start-up transient.

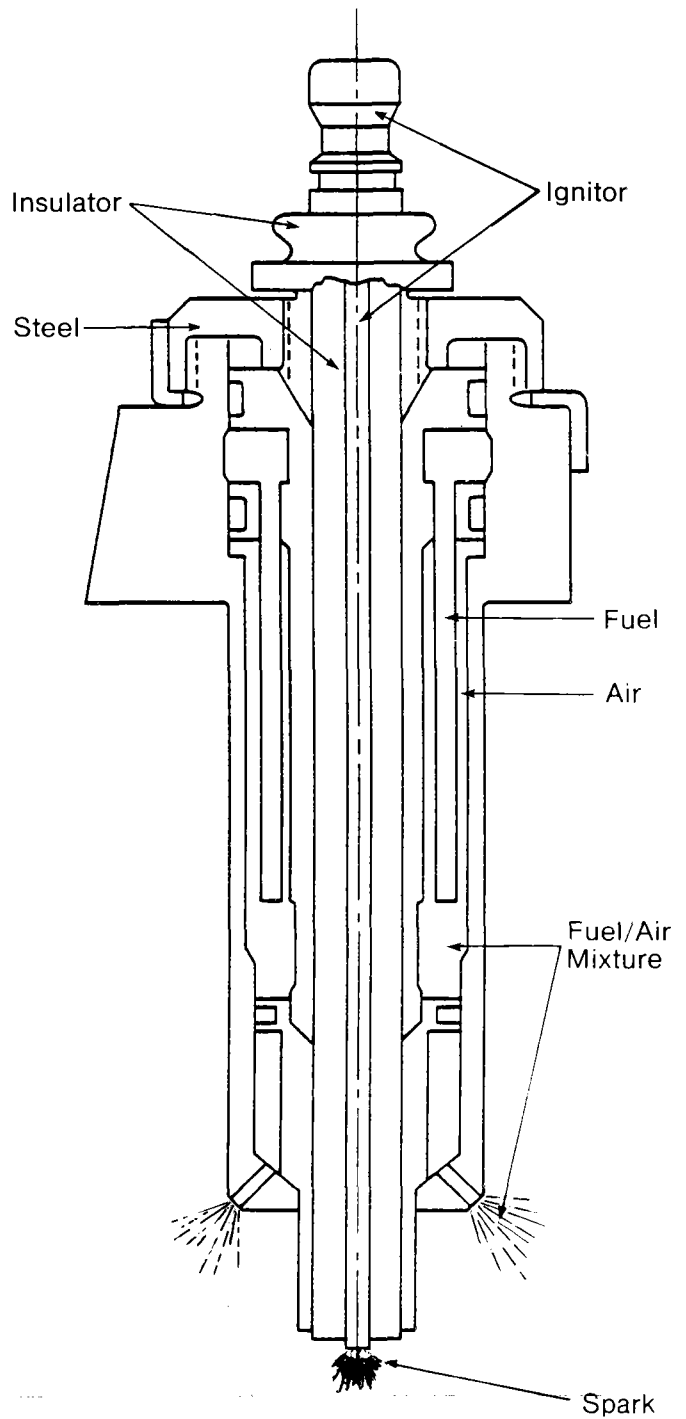

FUEL NOZZLE AND IGNITOR

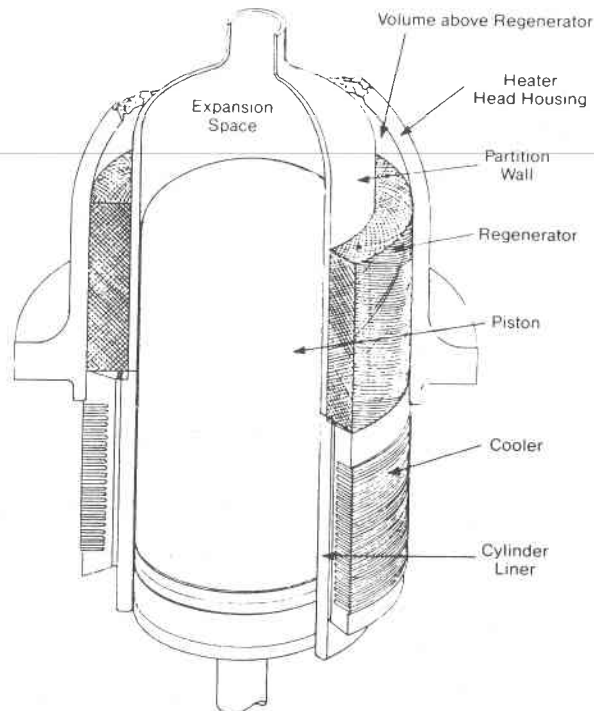

**TYPICAL ANNULAR
HOT ENGINE SYSTEM**

HOT ENGINE SYSTEM

The hot engine system consists of two heat exchangers that are directly involved in the operation of the Stirling cycle: the heater head and the regenerator. Both contain hydrogen and impart heat to the hydrogen that, in turn, provides the force to drive the pistons and thus powers the engine crankshaft.

The heater head transfers the heat contained in the hot combustion gas provided by the external heat system to the hydrogen. The heater head is constructed of many fine tubes. Hot combustion gas passes over the external surfaces of these tubes while the hydrogen passes through the internal surfaces of the tubes. It is the metal temperature of the tubes that sets the metallurgical limit of the heater head design.

A matrix of fine wire mesh, the regenerator is also a heat exchanger by virtue of its construction. As the hydrogen flows from the hot heater head to the cold cooler, it passes through the regenerator where a transfer of heat occurs. This transfer is accomplished by the wire mesh absorbing the energy. When the pistons push the hydrogen in the opposite direction, from the cooler to the heater head, it passes through the regenerator and absorbs heat from the wire mesh.

It is this transfer-absorption phenomenon that enables the Stirling cycle to operate efficiently. After passing through the regenerator on its way to the heater head, the hydrogen is already hot and therefore requires less heat to raise it to operating temperature. Additional heat to raise the hydrogen to operating temperature comes from heat transferred through the heater head tubes from combustion gas as explained above. From this point, the Stirling cycle repeats itself. The hydrogen is heated and expanded, which provides the force to drive the piston.

Heater Head

A heater head has three functions. First, it delivers the hydrogen to the top of the piston to convert high pressure forces into work through the downward motion of the piston. Second, it passes the hydrogen through a finite length of tube so that heat can be transferred to it from the combustion gas. This is normally accomplished by passing hydrogen through many separate tubes, whose external surface is heated by the combustion gas. The internal surface of the tubes is cooled by the hydrogen which picks up heat from the tube wall and carries this energy to do the work of the Stirling cycle. Third, the heater head delivers the hydrogen to the top of the regenerator through which it must flow on its way to the cooler.

There are many variations in heater head configurations to address these functions. The Mod II hot engine system is an annular configuration.

As shown, the regenerator and cooler are concentric with the piston and separated from it by a partition wall that also separates the regenerator from the expansion space above the piston. The hydrogen travels from the expansion space to the volume above the regenerator through the heater head.

As hydrogen flows out of the expansion space, it is collected in a manifold. Thus, the first function of the heater head is met. An array of tubes is placed in the front manifold through which hydrogen will pass and pick up heat from combustion gas. The tubes extend upward and then back downward to bring the hydrogen to the volume above the regenerator.

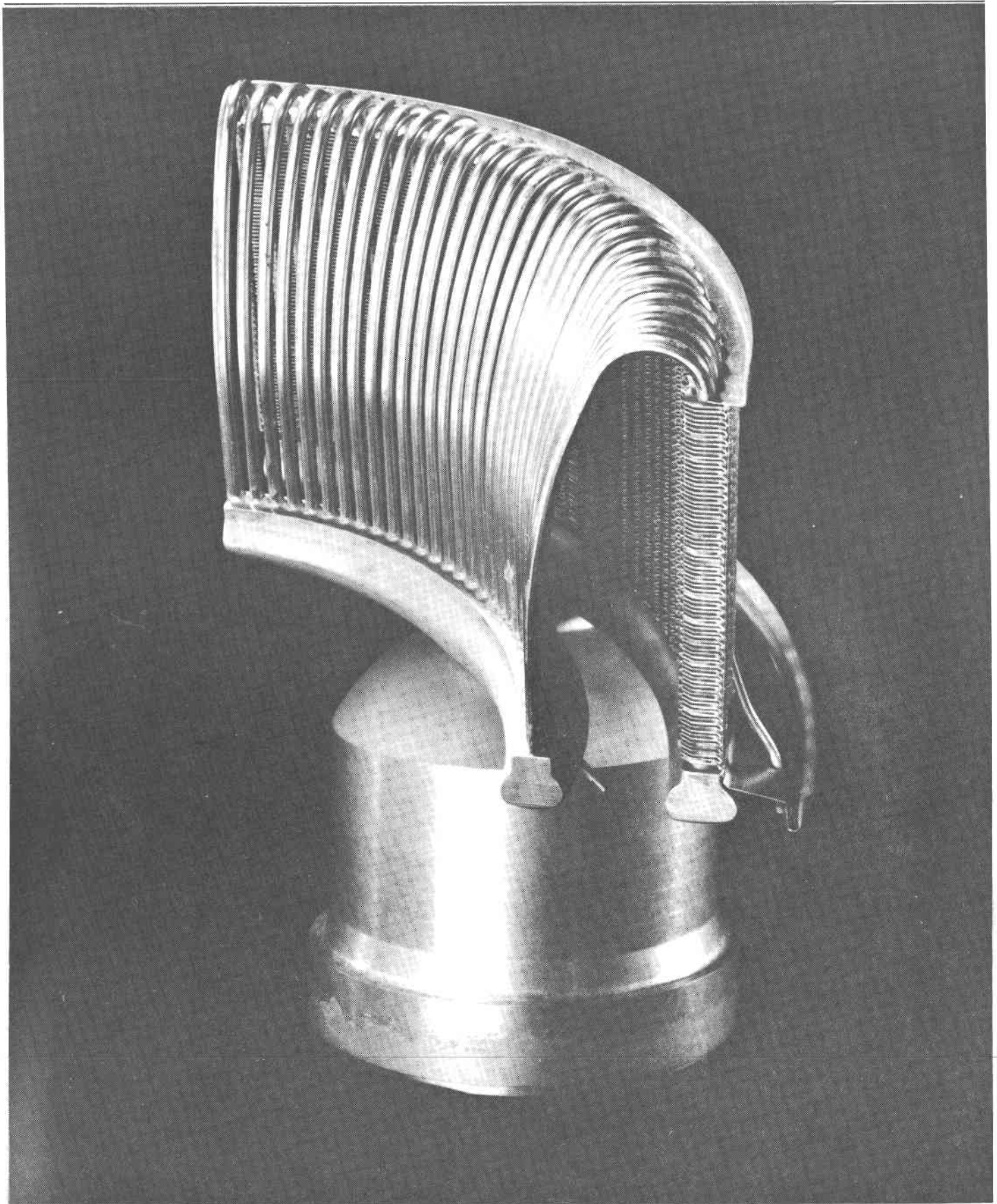

TYPICAL ANNULAR HEATER HEAD

When combustion gas passes over the external surfaces of the front row tubes, the temperature of the gas will decrease since a portion of its energy has been transferred to the hydrogen inside the tube. In order to enhance the heat transfer through the rear row tubes, fins are placed on the external surface of the tubes to increase the surface area for heat transfer and to reduce the flow area of the combustion side. The raised areas that provide fin-to-fin spacing are located to encourage combustion gas flow close by the tubes (rather than through the fin tips). At the rear row, the fin section helps to maintain the tube spacing. Thus, the second function of the heater head is served, since over a finite length of heat exchange surface (the tubes), energy from the combustion gas is transferred to the hydrogen inside the tubes.

The only remaining function is for the hydrogen to be delivered to the top of the regenerator. In the configuration shown in the photograph, this is accomplished by another manifold into which the tubes are brazed. However, in the Mod II heater head design, the rear tubes are bent around and imbedded in the housing, entering just above the top of the regenerator. This avoids the need for a manifold below the rear row of tubes.

Since the Mod II has four cylinders, it has four heater head assemblies that are mounted on the top of the engine block. Because of the V-drive configuration, each assembly is at an angle to the other. The front and rear row tubes of each heater head assembly combine to form a circle. The resulting configuration is symmetric to the combustion volume and preheater of the external heat system. This helps achieve an even flow through the heater head tubes and preheater and results in no abnormal variations in temperatures from one area of the engine to another.

The heater tubes attach horizontally on the inner face of the manifold. On the regenerator side, bosses are provided on the top face of the housing where the tubes attach.

Regenerator Assembly

The regenerator assembly consists of the regenerator matrix and partition wall. Individual wire-mesh screens are stacked, pressed, and vacuum sintered into a single annular biscuit. This ring is turned on its inner diameter and slipped over the thin metallic partition wall. The partition wall separates the cylinder/expansion space from the regenerator flow channel, and its cylindrical shell is flanged outward

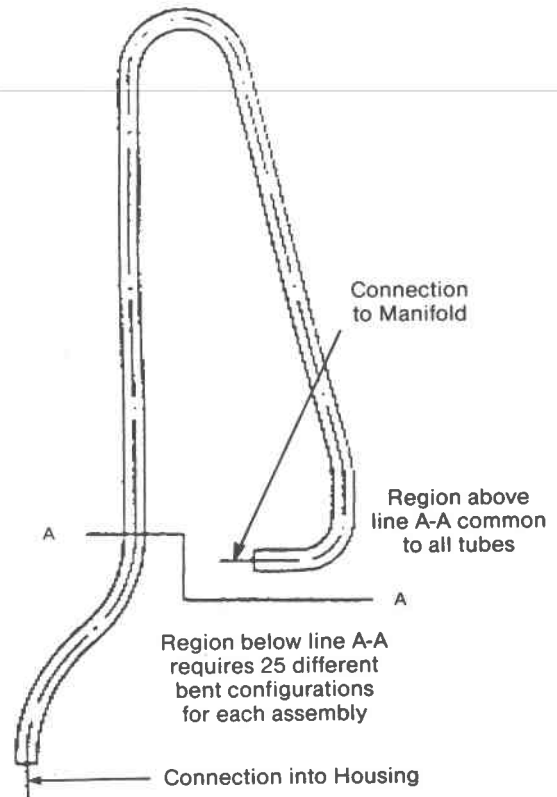

MOD II HEATER HEAD TUBE

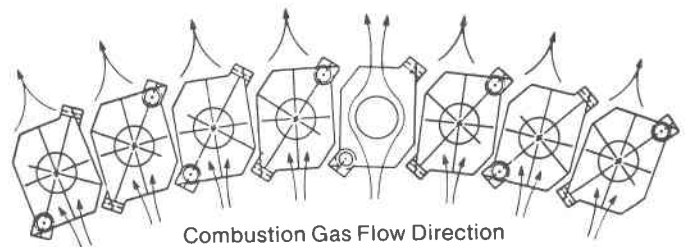

FINS ON REAR ROW TUBES

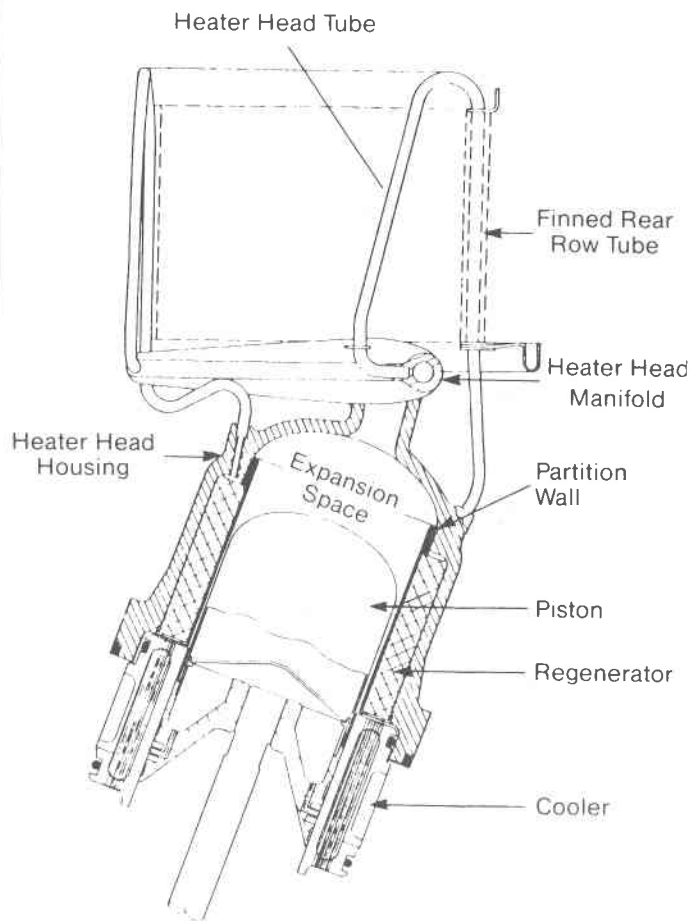

MOD II HOT ENGINE SYSTEM

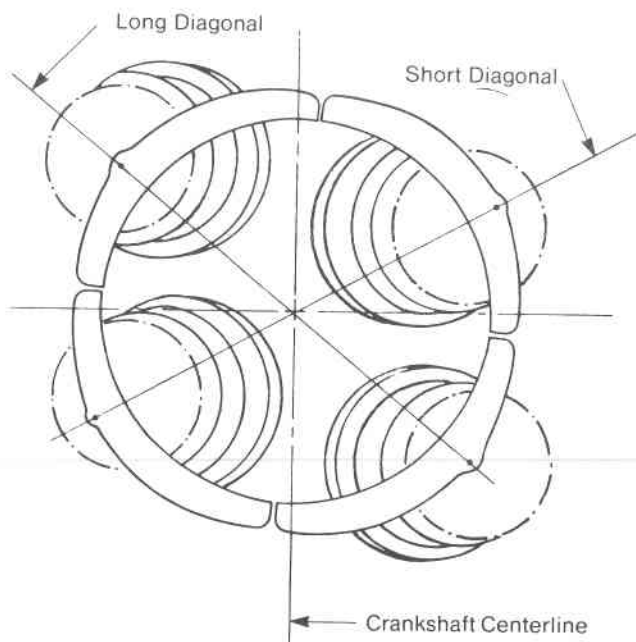

HEATER HEAD ASSEMBLIES

at the cooler end to act as a spacer between the regenerator and cooler. This assembly is vacuum brazed and then final machined to ensure inside-to- outside concentricity.

Stainless steel is used as the matrix material, since it has a thermal expansion about 20% higher than the housing material and excellent heat capacity. Use of this material results in a tight fit between the top of the partition wall and the housing at high temperatures. A good seal at this point is required to prevent hydrogen from bypassing the heater from cylinder space to regenerator or the reverse. Inconel 718, the partition wall material, has a thermal expansion slightly above the housing material and a high yield strength. To ensure that no gap occurs between matrix and partition wall, the Inconel 718 wall is nickel plated and brazed to the matrix.

The regenerator is pressed directly into the heater head housing with no outer shell. With the difference in thermal expansion between the housing and the stainless steel regenerator, there is no need for a tight fit between the housing and matrix to stop hydrogen from bypassing the regenerator from hot to cold side or reverse. The upper end of the partition wall is a separate machined ring that is brazed to the shell and provides the seal between the wall and housing.

COLD ENGINE/DRIVE SYSTEM

The cold engine/drive system transfers piston motion to connecting rods and then converts the reciprocating rod motion to rotary motion. It consists of the engine block, gas cooler/cylinder liners, seal housing assemblies, piston and connecting rod assemblies, crankshaft, bearings, and lubrication and cooling systems. Note that the gas cooler is the third and final heat exchanger in the closed Stirling cycle. The hydrogen transfers its heat into the cooler through an array of tubes that are cooled on their outside surface by water. This water is provided by the vehicle cooling system and cycles through the radiator.

The cold connecting duct, which is cast in the engine block, affects Stirling cycle performance. Dead volume and pumping losses are intensified in this cold region because of the increased hydrogen density. Minimizing both requires minimizing cylinder-to-cylinder spacing to provide short ducts of adequate flow area. Adequate provision for cooling water flow must also be made. To achieve maximum engine performance, all cylinders should run as close as possible to the same low temperature; therefore,

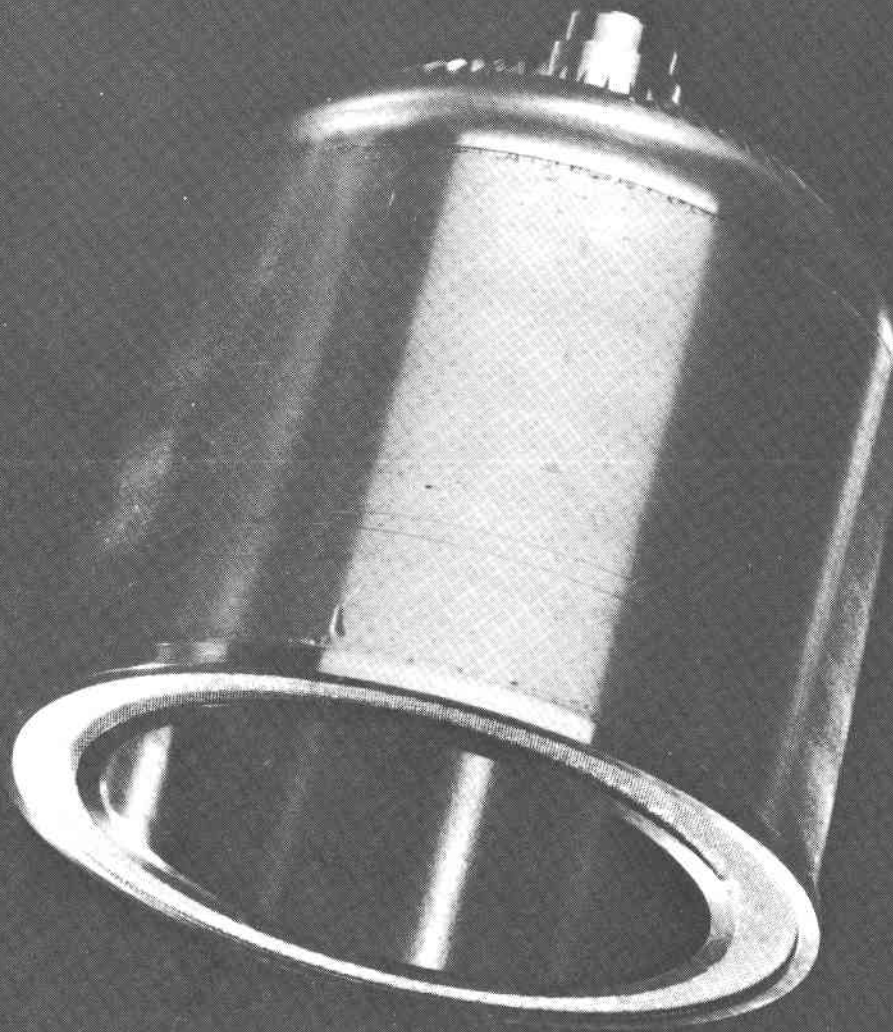

TYPICAL REGENERATOR ASSEMBLY

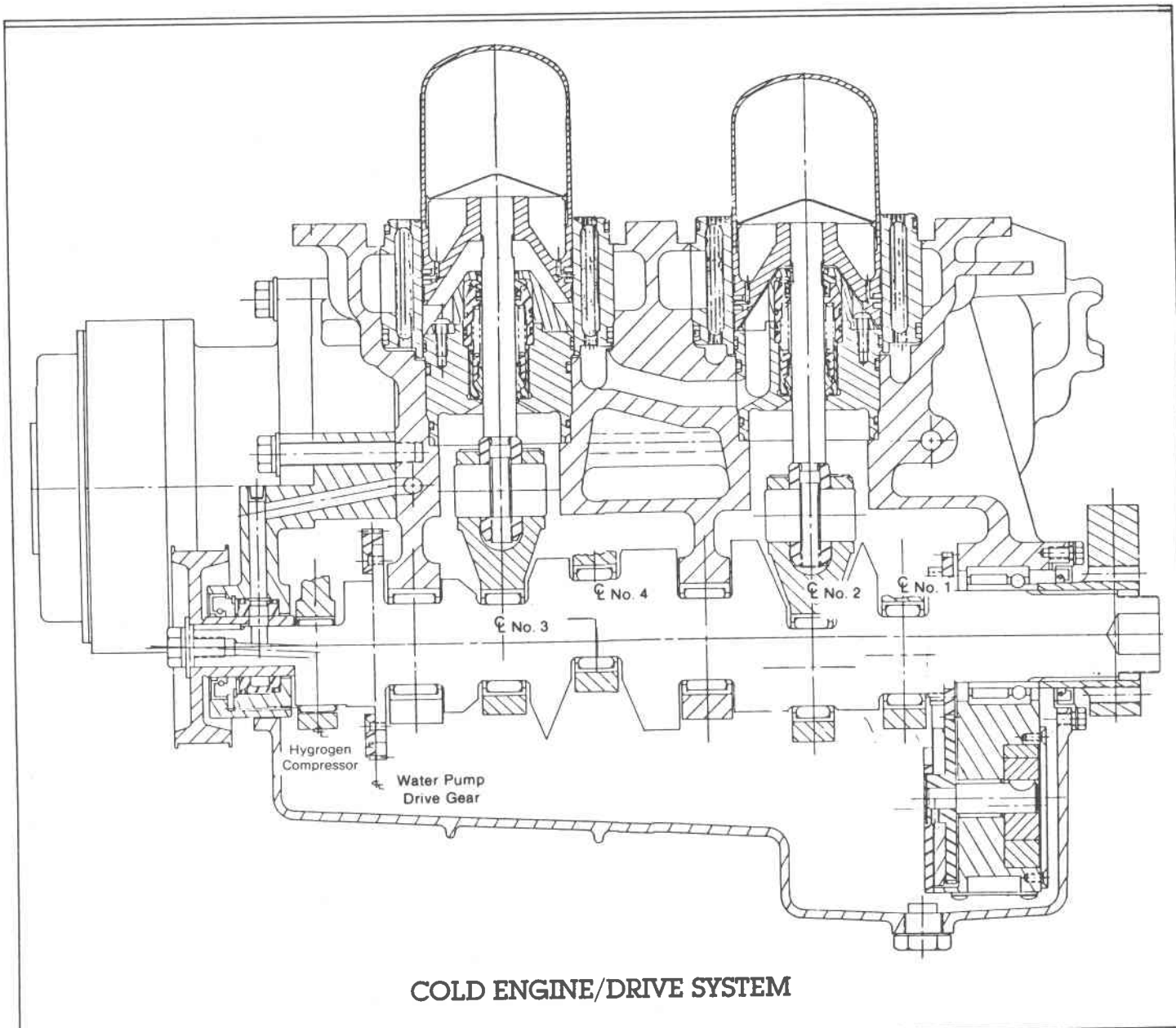

COLD ENGINE/DRIVE SYSTEM

coolant flow balance is very important. Minimum cooling water pumping power is obtained by arranging the coolers in parallel flow, but because the total pressure drop is much lower in that pattern, balancing becomes more difficult. Attention must be paid to the symmetry of water passages and concentration of pressure drop at the coolers in order to ensure the best performance. These demands shape the engine block design since the space claims of cold ducts and water passages are the dominant features.

Engine Block

The basis for engine construction is the unified cast iron engine block. This single structural element establishes the basic geometry of the engine and incorporates a water jacket, cold duct plates, cross-head liners, and a crankcase. It also provides alignment to critical components and an attachment base for the assembly of all other parts. Control lines are directly embodied in the casting, greatly reducing external plumbing complexity.

The cast block is a four-cylinder unit with the cylinders arranged two each on two banks separated by an angle of 40° (around the crankshaft axis). This equal-angle V is in contrast to earlier double-acting V Stirling engines, which used four nonparallel

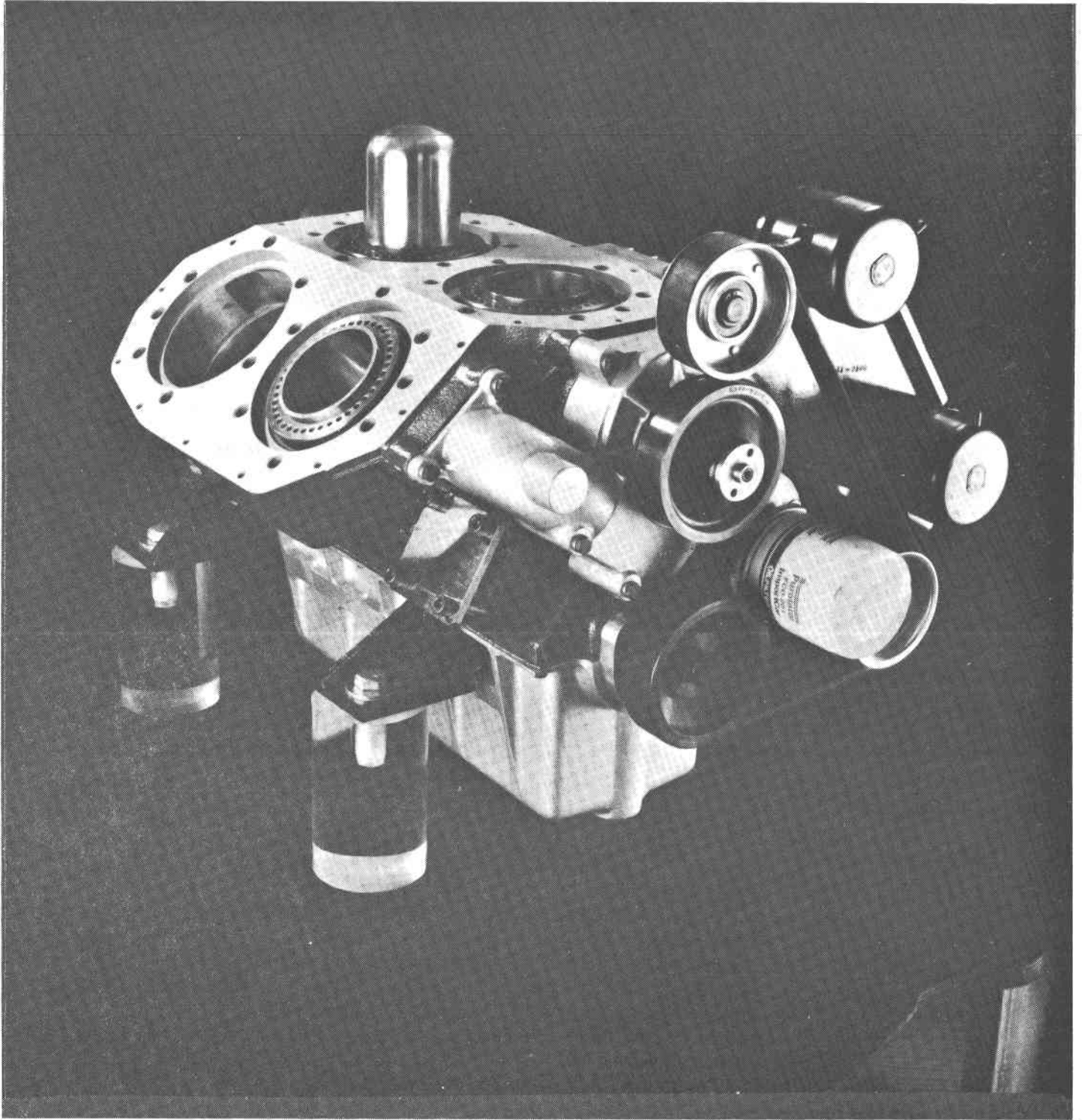

PISTONS PROTRUDING THROUGH COOLERS

--	--

cylinder axes to approximate a square array at the heater manifold plane. The two-bank, single-crank design provides cylinder axes that intersect the crank axis located in the plane of the bottom face (machined) of the block. The bottom face is parallel to the top face (machined deck) of one bank, and both banks have a full deck perpendicular to the cylinder axes and bores. Each bore accepts a cross-head, seal housing, intercycle seal, lower cooler seal, cooler guide diameter, and water seal at the heater flange (in order, from bottom to top). These various machined surfaces are arranged to have ascending diameters. This allows finish machining of the bores from the deck (top) sides with one form tool plunge cut each.

The single-tool finishing cut provides excellent concentricity control even in high-volume, transfer-line production. After machining the cylinder bores, the main bearing caps are bolted into position and the final bearing mounting diameters are line bored. The two water passages are through cored and divided into four independent passages by small flow blockers located directly on the annular coolers. The cylinders are not cooled in series. Instead, a portion of the cooling water bypasses one cooler so that the subsequent cooler is not affected by a higher cooling water temperature. Headers for the two cooling water inlets and two outlets are thin-wall, tubular steel weldments.

The parts of the cold ducts called the cold rings manifold the hydrogen at the bottom of the annular coolers, allowing the hydrogen to flow through the cold pipes to the compression spaces of the adjacent cylinder. Small machined pads are located on each side of the casting to mount valve blocks, each serving two cylinders. An internal passageway is formed in the block casting to allow necessary interconnections between the pad-mounted blocks to remain totally within the engine block. This passage is formed by a sand core during the casting process. The sand core also improves control of metal cooling, porosity, and wall thickness around the cold ducts during the casting process, which ensures integrity of the pressure-containing walls of the cold ducts.

The engine block is sand cast in ductile or nodular iron alloy, with an ultimate strength of 544 MPa (80 ksi), yield strength of 374 MPa (55 ksi), and elongation of 6%. Ductile iron was chosen over ordinary (gray) cast iron because greater ductility is crucial to the safety and fatigue life of a vessel containing high cyclic pressure. Also, the spheroidal graphite structure of ductile iron eliminates the

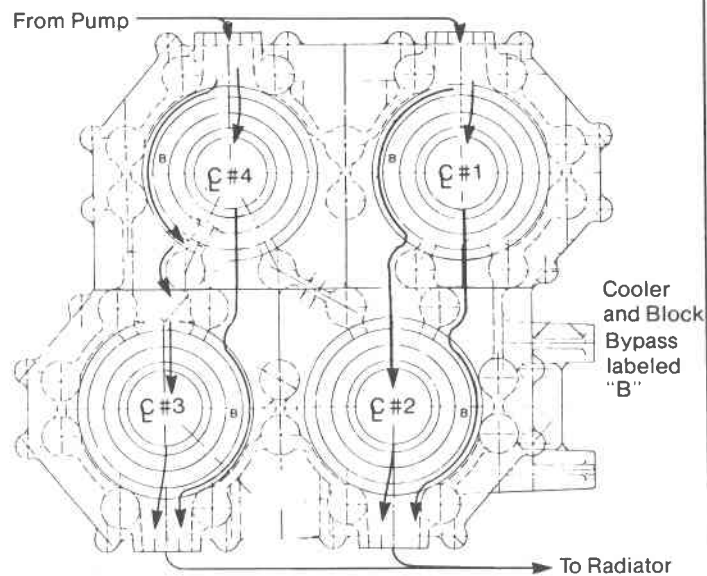

WATER PASSAGES

hydrogen permeation passages permitted by the lamellar carbon structure of gray iron.

Since accurate stress analysis of this complex shape would have required expensive three-dimensional numerical modeling, a very conservative approach was taken for approximate stress analyses in the pressurized regions. For instance, the cold duct rings are essentially cut toroids, but have been modeled as simple cylinders of their outermost diameter. Here, and everywhere else in the pressurized zone, the wall thickness is cast to 10-mm (0.394-in.) nominal. This wall thickness gives a safety factor against yield of 3.0. The maximum fatigue stress from 15 ± 5 MPa (2205 ± 735 psia) pressure (96 ± 32 MPa (14.1 ± 4.7 ksi) stress) gives a safety factor of 3.0, figured on a conservative straight line of the Goodman and Haigh diagram with an endurance limit 0.4 times ultimate strength.

The crankcase ahead of the main bearing is separately cast. Since there are no gas-pressurized zones in this front piece, it can be cast in lightweight alloy. This front cover incorporates the water pump and balance weight mounting, the compressor drive box, and the oil supply lines and bushing into an aluminum casting.

The oil pump is mounted on the rear main bearing cap. The pump and its balance weight are gear driven from the crankshaft and sit directly in the oil sump, so that no additional housing is required.

Gas Cooler/Cylinder Liner

The cylinder liner on which the piston rings slide contains the cycle pressure. The wear surface must be hard; thick and strong enough to contain the pressure and thin and conductive enough to allow its water-cooled exterior to carry away the heat of ring friction. In this annular design, end plates drilled for tubes are integral with the liner making it a kind of spool. Tubes are brazed into the end plates, and at the same time, segments are brazed to the outer diameter to leave in-and-out coolant flow windows to the tubed area.

The holes in the end plates are drilled in four concentric rings to give a constant tube center-to-center spacing. Six holes are omitted at the windows (180° apart), with the pattern of omissions providing inlet and outlet plenums for the circumferential coolant flow.

The cylinder bore diameter and the largest outer diameter (which guides the cooler in the block) must be cut in the same machining setup. This ensures minimal eccentricity and angular misalignment at final assembly between the finished cylinder and the crosshead bore in the block. Since the cooler pilots the heater head housing and partition wall/cylinder liner, good alignment is essential to prevent piston dome rubbing. After finish machining, the cylinder bore is exposed to plasma (ion) nitriding to harden the surface to Rockwell C66-70. A final honing of the hardened bore completes the processing.

The assembled gas cooler/cylinder liner is then fitted to the machined bore of the block. This fitting can also be done after the seal housing assembly is in place, allowing either component to be removed for service without disturbing the other.

Seal Housing Assembly

The seal housing assembly consists of a pumping Leningrader sliding seal, loading spring, cap seal, supply bushing, seal seat, and other small parts (such as O-rings) in a housing-and-cap container. The pumping Leningrader seal acts to seal hydrogen up to a pressure of 10 MPa (1450 psi) against an ambient-pressure crankcase with lubricating oil. The seal seat extends upward to form a guide for a spring follower to ensure that spring load is concentric and uniformly applied around the circumference of the main seal. The seal housing itself incorporates passages for adding and/or removing hydrogen from the closed Stirling cycle. Two O-ring seals, one to the cooler and one to the block, provide intercycle sealing between the compression



COOLER ASSEMBLY

space and surrounding cold ring. Two backup rings are included to withstand the reversing pressures. Isolation of supply and P_{\min} lines as they cross the joint (slip fit) between the seal housing and block is provided by expanding elastomer-over-steel tubing. This fitting is specially designed to press outward on its containing bore without producing any end loads that would tend to drive the seal housing off-center in the cylinder bore.

A major function of the seal housing is to provide oil jets that keep the main seal lubricated and cool. A single main oil gallery is drilled through the center of the block, intersecting the seal housing bore of each of the four cylinders at its lower extreme, just above the crosshead bore. An oil hole is drilled 90° in each direction from the intersection of the main gallery, and an oil jet tube is inserted, aimed at the base of the main seal. This location, because it falls between the crosshead faces, ensures no occlusion of the oil jets by the crosshead near top dead center with consequent temporary starvation of the seal. The actual sealing elements on the rod are compounds of Rulon[®] (a filled polytetrafluoroethylene material).

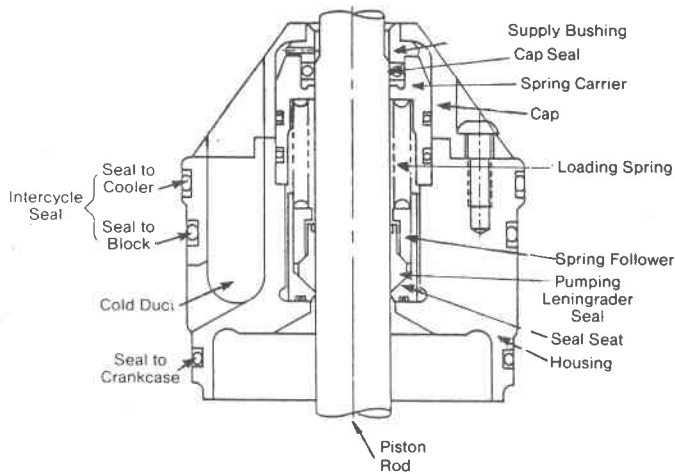

SEAL HOUSING ASSEMBLY

Piston and Connecting Rod Assembly

The lightweight piston design integrates the piston base, piston dome, and piston rod into a single, shrink-fit welded component that is assembled to the connecting rod and crosshead unit. The crosshead is a separate part, acting in concert with the wrist pin to form a joint between the connecting rod and piston rod.

The piston configuration includes two sets of rings per piston. The sets are adequately separated to allow any hydrogen leakage to vent through the piston rod and relieve any pressure buildup between the rings. Venting the gap between the rings minimizes leakage of the hydrogen past the rings. Each set is composed of two rings; one ring is solid and the other is split. This configuration is termed a split-solid piston ring. The solid ring minimizes hydrogen leakage between it and the cylinder wall during engine operation. The split ring ensures cylinder wall contact during a cold start when a solid ring would not normally seal against the cylinder wall.

The piston base is machined from steel and acts as both the dome base and piston body. The piston dome is formed into a hollow, thin-walled cylinder with a curved-top and open bottom. A radiation shield is placed above the base, the dome is slipped on around it, and the whole assembly is electron-beam welded. Because the dome is permanently fused to the base, better angular control of the dome is obtained. This ensures that a uniform dome wall

of the proper thickness is maintained after final machining of the assembly and ensures adequate dome-to-cylinder running clearance. Two guide rings and two sets of piston rings are mounted in grooves machined in the piston base. The piston dome, base, and guide rings are all final machined after assembly to maximize dimensional control.

The piston rod is machined from Nitralloy 135-M steel. After nitride hardening, the surface that contacts the main seal is highly polished. Exceptional hardness and surface finish are essential to prolong seal life. The rod has a drilled vent hole through the top and out the side to maintain minimum cycle pressure between the piston rings. The piston rod is separate from the crosshead. Since the piston is attached to the rod prior to final engine assembly, the piston must be installed through the top of the cylinder. The rod is carefully pushed through the pumping Leningrader seal and then threaded into the crosshead.

The piston rod is attached to the piston base by means of a shrink fit. The shrink fit is easy to assemble, allows good control of the dome height, and prevents damage to the mating surfaces during assembly. The joint at the top of the assembly (inside the piston dome) is welded to form a gas-tight seal.

The connecting rods are a split-fork type using rolling-element bearings in the lower end and journal bearings in the top end. The power-piston connecting rods are fractured on the centerline of the large bore for assembly onto the crankshaft and held together with bolts. The hydrogen compressor connecting rod is one piece and slips over the end of the crankshaft. The inner surfaces of the bores serve as the outer races for the roller bearings.

The crosshead supports lateral forces exerted by the connecting rod and allows only vertical motion of the piston rod as the rod passes through the main seal. The lateral motion of the rod at the seal location must be minimized. The crosshead reciprocates in a guide bore machined in the engine block. To ensure good wear, the cylindrical or bearing surfaces of the crosshead are hardened and ground to a smooth finish. Since the rod and piston are assembled first, the crosshead must be a separate part to allow the rod to be inserted through the pumping Leningrader seal. A threaded assembly is used between the piston rod and the crosshead. Centerline eccentricity between the two is controlled with a diametral fit between the piston rod shank and the pilot bore in the crosshead. The angular alignment between the rod and crosshead axes is established by accurately machined shoulders on the rod and the top of the crosshead.

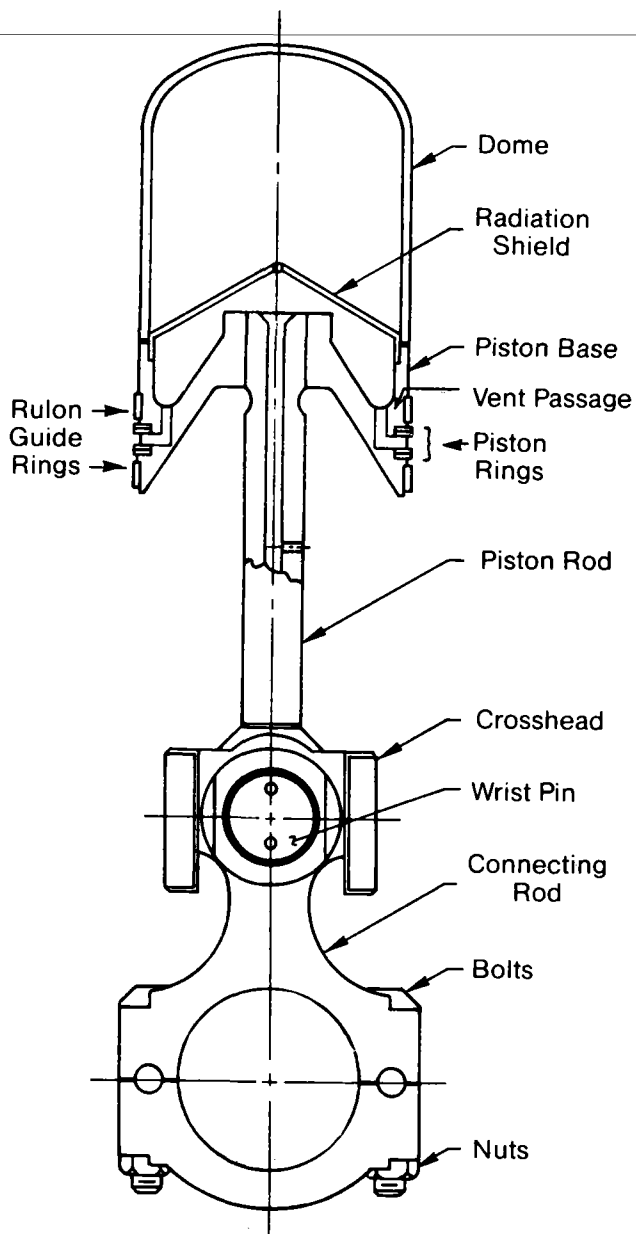

PISTON AND CONNECTING ROD ASSEMBLY

The wrist pin is machined from low-alloy steel. A radial hole is bored through the center to accommodate the shank of the piston rod as it is threaded into the crosshead. The wrist pin acts as the journal in the upper end bearing of the connecting rod and has a hardened, polished surface. This bearing is lubricated with excess oil initially sprayed at the piston rod to lubricate and cool the pumping Leningrader seal.

The crosshead is fitted between the yoke arms of the connecting rod and is held in place with the wrist pin. The wrist pin is pressed into the crosshead to prevent the pin from slipping. A minimal amount of interference between the two parts is used to keep the stresses due to the fit at a minimum. This avoids deformation of the crosshead bearing surfaces and damage to the wrist pin surfaces.

Crankshaft

One crankshaft carries the crankpins for all four pistons and the hydrogen compressor crankpin on three main bearings. Two power-piston crankpins are supported between each main bearing, while the compressor is overhung. The extremely low stroke of the Mod II (30 mm (1.18 in.)) compared to spark ignition engines of similar power and speed (60 to 100 mm (2.36 to 3.94 in.)) allows greater overlap between adjacent journal sections and provides an extremely stiff crankshaft, especially in torsion. Simultaneously, the reciprocating elements are joined by a short, forked connecting rod in order to minimize the overall height of the engine. The result is a very compact crankcase, with a shaft that is stiff enough to allow balancing forces and torques to be carried through it. That stiffness allows the use of a unit balance. The imbalance forces from the pistons, connecting rods, and compressor are totaled, and two-plane balancing is applied using rotating eccentric masses at the extreme ends of the shaft (outboard of the main bearings and the crankcase proper). In fact, some balancing is done with the central portion of the crankshaft where space is available, but most is done by the end weights. Another advantage of the unit balance technique is that it provides a minimum mass solution to the balance requirement by taking advantage of inherent cancellations between imbalance forces.

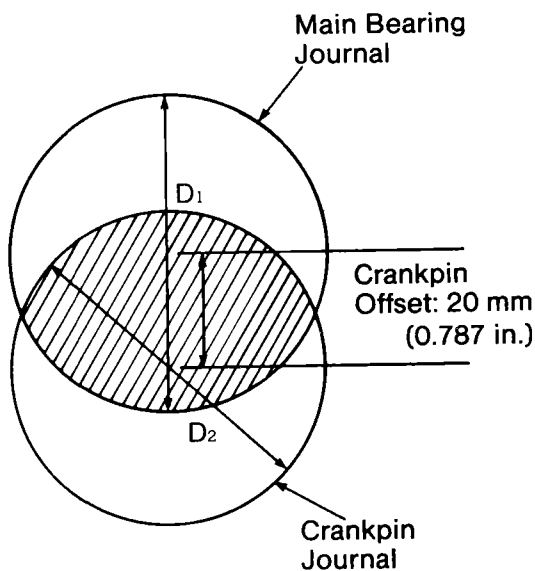
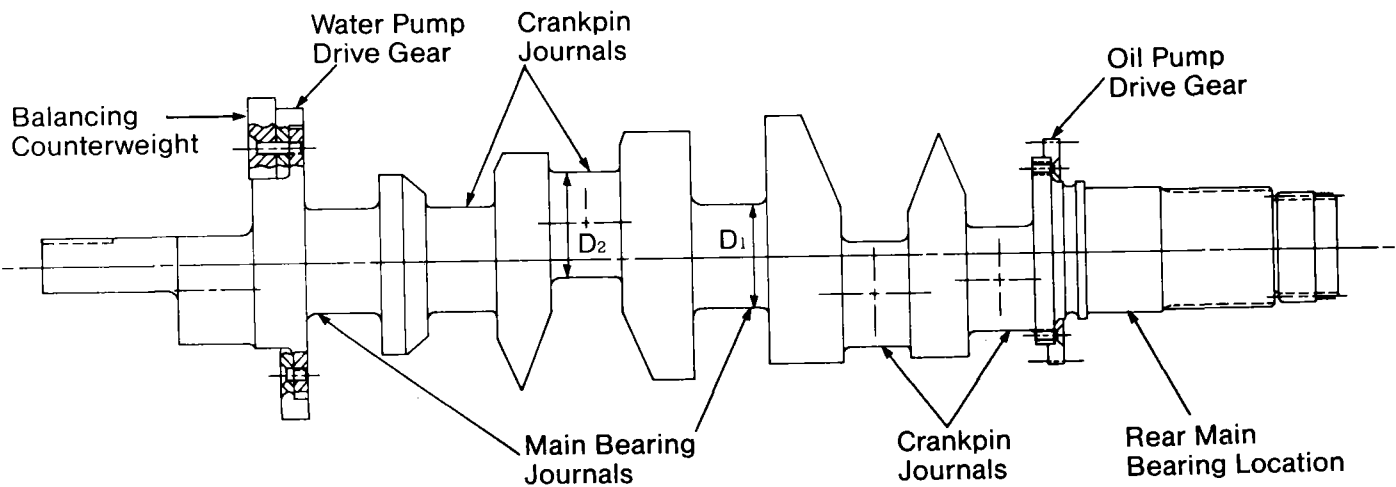

CRANKSHAFT

Because the Mod II drive incorporates roller bearings for all mains and crankpins, the journals on the crankshaft are hardened and ground to provide inner races. Roller bearings put special requirements on material hardness, purity, and surface finish of the crankshaft. The crankshaft is machined from a forging of low-alloy steel, which is case carburized on all journals, keyways, and the splined output end. The shaft configuration allows assembly of a nonfractured roller/ball thrust bearing unit at the rear main bearing and a nonfractured race bearing on the compressor crankpin. After finish machining and hardening, the journals are precision ground to roller race surface quality.

To provide oil to the crankpin bearings, the pressured oil from the pump and filter is passed via a floating bushing at the extreme end of the crankshaft (outboard of the compressor) into internal drillings. These drillings then feed oil to the five eccentrics via restricted outlet drillings. Main bearings are fed directly from the main oil gallery in the block by drillings and orifices to their outer races.

To drive the oil pump and the water pump at engine speed (but in opposite rotation as required by the balance scheme), gears are provided on the crankshaft assembly. The shaft itself includes hubs to which separately formed gears are attached. This simplifies manufacture of the crankshaft by eliminating the process of cutting gears on the crankshaft.

Bearings

The Mod II incorporates rolling-element bearing technology. The crankshaft rotates in three main bearings. The front and center main bearings are split-cage roller bearings that run directly on case-hardened journal surfaces of the crankshaft.

Fractured half-shell outer bearing races are retained in the crankcase and bearing cap bore in the same manner that conventional journal bearing shells are retained. The rear main bearing is a combination roller/ball bearing assembly that can be fitted onto the crankshaft without being split. The ball bearing portion of this bearing provides positive axial location of the crankshaft with respect to the crankcase and supports the axial load imposed through the throw-out bearing when the clutch is disengaged. The roller bearing portion sustains the radial loads in the same manner as the front and center main bearings.

The rear main bearing is held in place on the shaft, together with the splined output drive hub, by a single nut that clamps both parts axially against a shoulder on the shaft. The rear shaft oil seal provides a sealing lip that rides on a smooth-finished sleeve extension of the drive hub. The seal is held in the crankcase by a small retaining flange. The gears are fitted and screwed to the hubs fore and aft. The attachment screw patterns are intentionally asymmetrical to ensure that each gear, which carries a timing mark, can be fitted only one way. This also ensures that, when the matching marks on the counterrotating pump gears are aligned, the counterrotating weights they carry will be properly phased to give the intended balancing. The other two main bearings, in halves, are assembled to the crankshaft as it is laid into the block and retained by attaching the main bearing caps. The front cover, with the compressor connecting rod, the oil supply bushing (porous bronze), and front seal already installed in it, will be slipped on over the end of the in-place crankshaft, engaging mounting/locating studs on the block.

BEARING CONFIGURATION

Journal Diameter	38.40 mm (1.51 in.)
Bearing Outer Diameter	53.00 mm (2.09 in.)
Mean Diameter	45.70 mm (1.80 in.)
Roller Diameter	7.30 mm (0.29 in.)
Number of Rollers	14.00 mm (0.55 in.)
Roller Length	24.80 mm (0.98 in.)
Cage Space Between Rollers	2.95 mm (0.12 in.)
Dynamic Capacity	45,060 N (10,129 lb)
Maximum Misalignment	4.3 minutes of arc

The connecting rod crankpin bearings are split-cage roller bearings, wherein the crankshaft journals act as inner races and the connecting rod bores as outer races. Both surfaces are case hardened and ground to virtually the same hardness and surface finish found on individual bearing races. The crankpin bearing for the hydrogen compressor connecting rod can be assembled onto the crankshaft without being split, so a standard roller bearing with full cage is used at this location. Conventional fluid-film bearings based on squeeze-film lubrication are used for wrist pin bearings on all connecting rods.

Sizing and selection of the main and crankpin roller bearings were determined by the operating duty cycles and life objectives set for the engine. Two concurrent objectives were established: 100 hours of continuous operation at maximum power conditions and 3500 hours of operation at conditions equivalent to those of the EPA combined driving cycle. The bearing design configuration was defined to meet these operating life objectives under the loads imposed on the bearings by the pressure forces acting on the pistons and transmitted through the connecting rods. The results of the operating life analysis for EPA driving cycle conditions are shown on the following table.

COMBINED EPA DRIVING CYCLE BEARING L₁₀ LIFE

Bearing	Bearing L ₁₀ Life				
	M2	M3	M4	Hydrogen Compressor	Crankpin
Dynamic Capacity, N (lb)	45060 (10129)	45060 (10129)	45700 (10273)	20000 (4496)	45060 (10129)
Equivalent Load, N (lb)	4576 (1029)	3674 (826)	4893 (1100)	538 (121)	6030 (1356)
Equivalent Speed, r/min	1151	1151	1151	1151	1151
Life, h	29628	61611	24852	2.48 x 10 ⁶	11817
Equivalent Life Factor	1.37	1.37	1.47	1.37	1.37
Adjusted Life, h	40457	84129	36614	3.38 x 10 ⁶	16136

COMBINED EPA DRIVING CYCLE

Bearing	Bearing System Life				
	M2	M3	M4	Hydrogen Compressor	Crankpin
Reliability, 3500 h	0.9940	0.9974	0.9933	1.0000	0.9825

System Reliability for 3500 h = 0.9177
 Corresponding System L₁₀ Life = 4169 h

Lubrication System

The oil pump is a Gerotor element pump driven from the crankshaft by a gear set, which synchronizes the pump in reverse rotation and also provides a balance function. The pump is mounted in an extended rear main bearing cap, which hangs from the block into the oil sump. The pump elements are completely self-priming, since they are partially submerged in the reservoir. The expense of a separate oil pickup tube is avoided by fitting the filter screen to the lower face of the housing/bearing cap and drilling from there to the pump suction chamber. A relief valve limits oil discharge pressure to 350 kPa (3.5 bar). This limit is especially important with roller bearings that churn and heat up if excessive oil is provided. The pump outlet is drilled up into the block to a convenient mounting for the oil filter on what will be the front or radiator side

of the block, just over the starter in the Celebrity. Because of the sensitivity of roller bearings to particles, the filter is a 10-micron unit. From there, oil flows through drillings to the central oil gallery, which runs axially through the center of the V, intersecting the seal housing bores of all the cylinders to supply the piston-rod-seal oil jets. An additional oil jet taps off of the supply manifold around each seal housing to spray oil onto the crosshead sliding faces. Small wells are provided in the crossheads to trap runoff oil from these jets and to lubricate the crosshead faces and the wrist pin joints. In addition, there are three drillings from the main gallery to the main bearings.

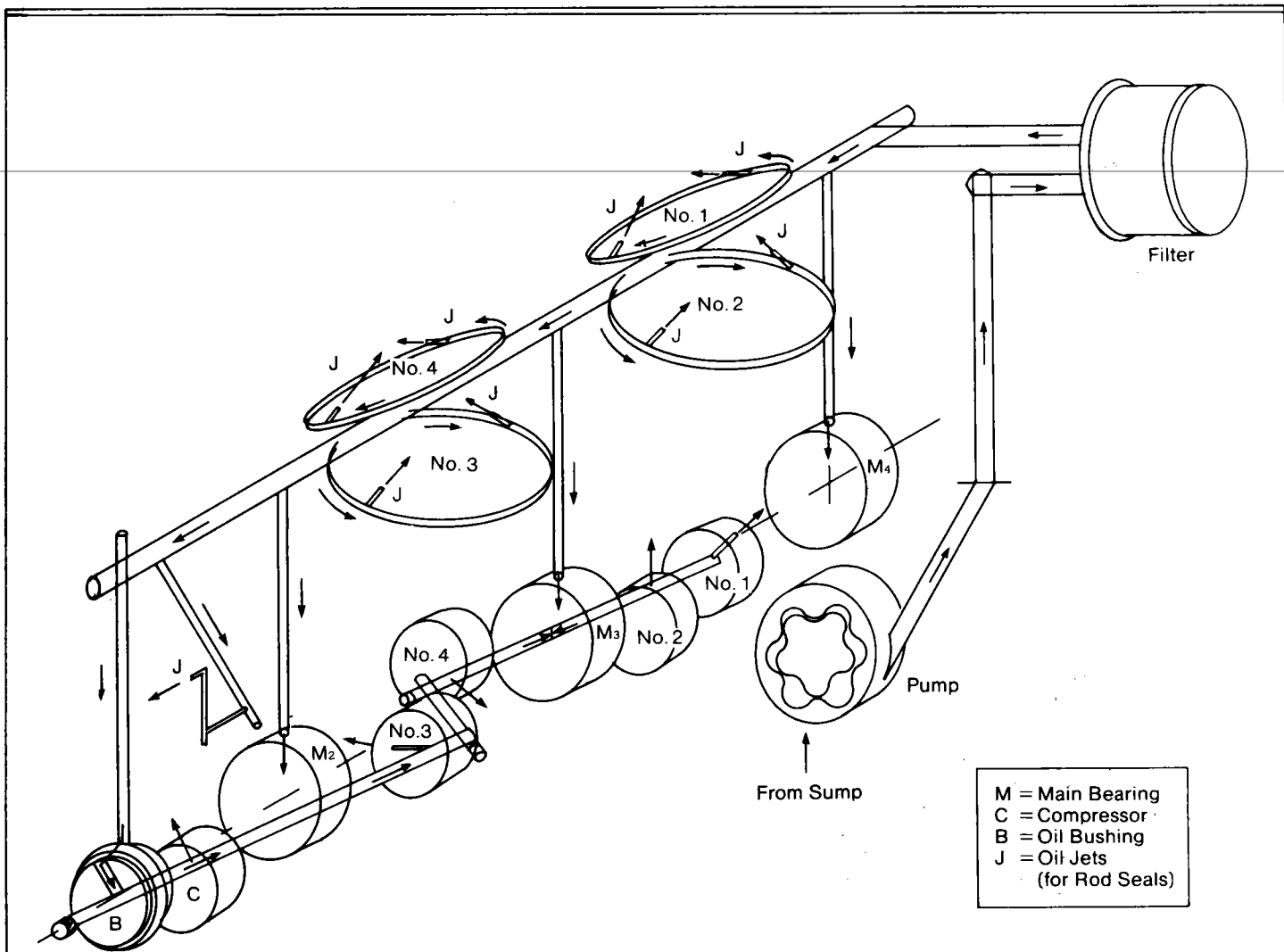

LUBRICATION SYSTEM

Where the gallery emerges from the other end of the block, it matches a drilling in the front cover. From there, oil is supplied by auxiliary drillings to the compressor-rod-seal oil jet and the crankshaft oil supply bushing. At that bushing, oil is pumped into

the rotating crankshaft, which is internally drilled and provides orifices for oil outlet at each of the five crankpin bearing races.

Cooling System

The majority of the cooling system is consistent with automotive practice, but the higher heat rejection and higher pressure required by the restriction of tubular coolers in the coolant flow path requires a special pump. The water pump is constructed from standard-size Gerotor elements in a specially designed aluminum cast housing. The central element is stainless steel, and the outer rotor is plastic to give lubricity against the stainless steel and aluminum parts in the water environment. The aluminum parts subject to sliding are hard anodized to prevent corrosion and galling.

The water seals are conventional carbon face seals that isolate the pump from a drive chamber. The drive chamber houses a crankshaft-driven gear and

its associated balance weight. Mounted on the outer face of the pump housing, an electric motor drives the pump as an aftercooling pump, precluding the need for a separate pump for that purpose. In order for the motor to turn only the pump, the drive gear is connected to the pump shaft through an over-running clutch. The motor is a pancake-type, dc unit; the motor rotor mounts directly on the pump shaft and free wheels during engine operation. It provides an aftercooling flow of 0.4 kg/s (0.9 lb/s) by turning the pump at 400 r/min.

The remainder of the cooling loop is as follows. At the pump discharge, water is manifolded through the coolers and around the cylinders. From there, it is gathered up again and passes through the radiator. The hydrogen compressor is cooled by a

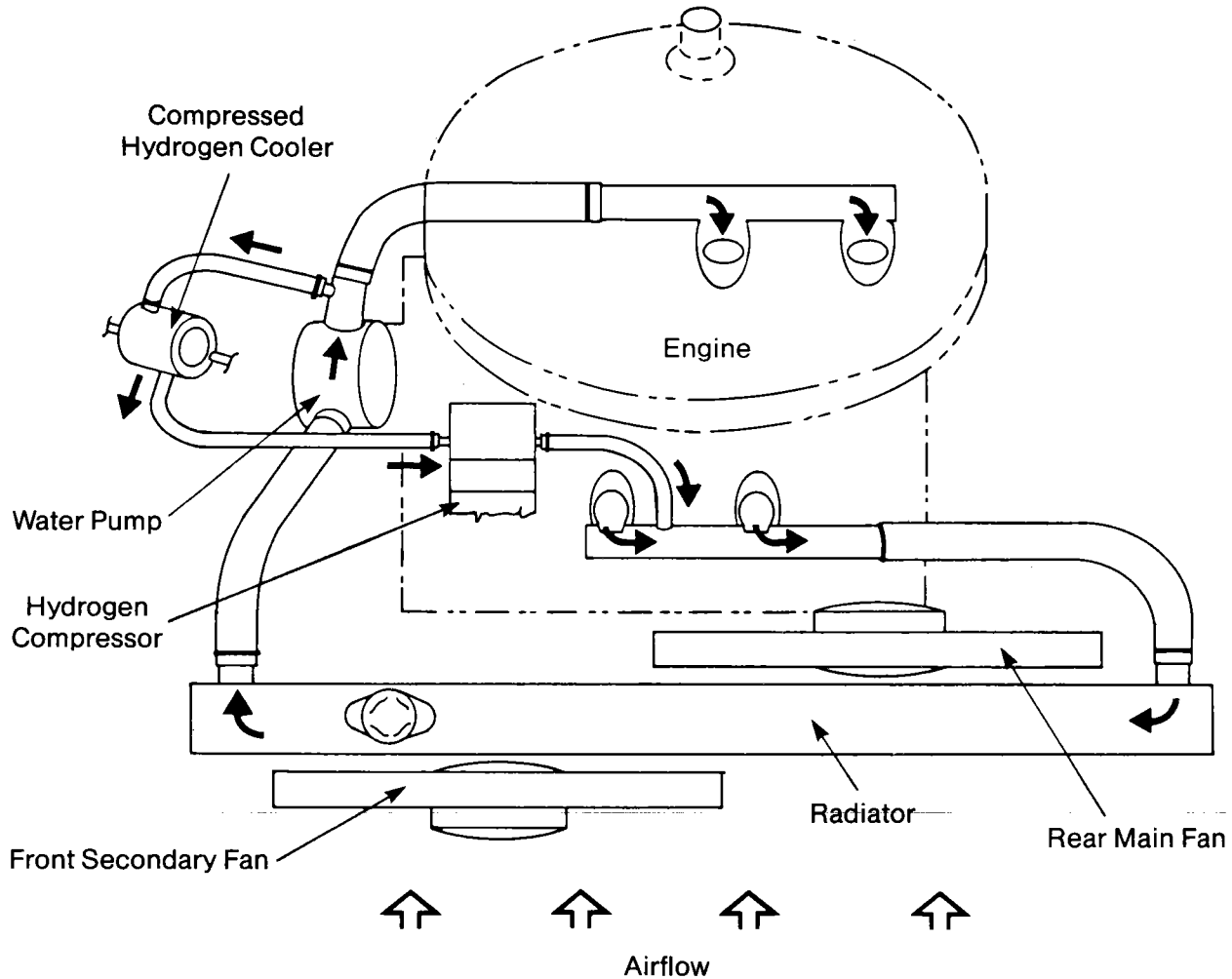

COOLING SYSTEM

small parallel pass, connected by standard small-diameter heater-supply hose. The entire loop is intentionally kept nonpressurized by a vented overflow tank and nonspring radiator cap in order to preclude the cavitation that might otherwise occur from the suction of the positive-displacement pump.

Engine Balance

All reciprocating-piston engines, including the Mod II, develop internal shaking forces and rocking moments from piston motion. These must be counteracted by a balancing system to provide smooth, low-vibration operation. The magnitudes of these forces and moments are proportional to engine speed (squared), with a primary portion causing vibration at engine speed and a secondary, lesser portion causing vibration at twice that frequency. Application of rotating, eccentric balancing masses (as commonly done on the crankshaft) provides rotating balancing forces that can only partially compensate for the reciprocating imbalance unless (at least) two sets of balance masses are used, rotating at equal speeds, but in opposite directions. This twin-shaft system can produce a near-perfect cancellation of reciprocating imbalance but at a penalty in size and complexity. However, an earlier generation automotive Stirling engine, having a U-drive with two crankshafts and a separate counterrotating output shaft, incorporated a full primary balance by this technique without additional complexity.

In recent automotive production engines, a pair of shafts as described above has been employed at twice engine speed to eliminate the secondary imbalance which is significant in such higher speed, longer stroke engines.

In an automotive Stirling engine, the speeds are relatively low and the stroke quite short, greatly reducing the size of the secondary imbalance. However, the Stirling has considerably more massive pistons than do conventional automotive engines, making the primary imbalances larger. For this reason, the usual partial balancing of primary imbalances with one set of rotary masses on a single crankshaft will not suffice for the Mod II.

A system has been devised to provide near-perfect primary balance without returning to the multishaft complexity of earlier automotive Stirling engines. This system, shown in the balance system schematic, uses the inherent requirement for oil and water pumps, driven by the crankshaft, to provide counterrotating masses without additional balancer shafts.

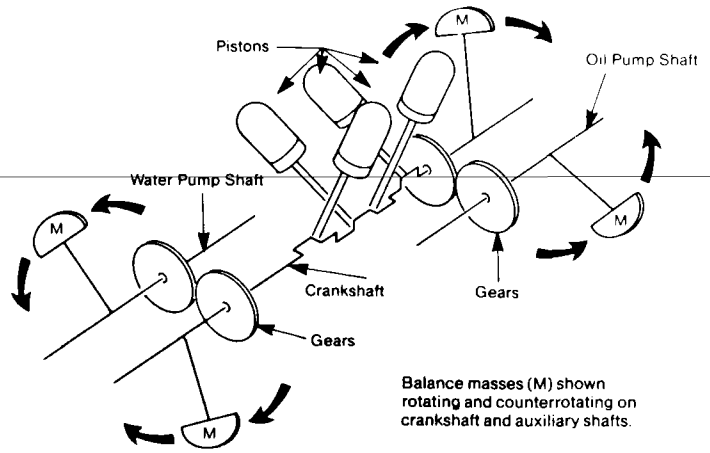

BALANCE SYSTEM SCHEMATIC

The water and oil pumps each carry an eccentric rotating mass. Both pumps are gear driven at reverse engine speed. They are located on opposite sides of the crankshaft, one near each end, so as to approximate the effect of an ideal balance shaft (concentric to the crankshaft) with a virtual shaft axis running pump-to-pump, nearly through the center point of the crankshaft.

A further simplification of the balance system results from the high torsional and bending stiffness of the low-stroke crankshaft. This stiffness allows imbalance forces and moments to be transmitted along the crankshaft and resolved with a single balance mass pair, rather than individual balance masses at each cylinder. The masses of this pair are located near the ends of the crankshaft for most effect (least weight). The absence from the central crankshaft of large-radius, rotating masses, together with the short piston stroke, allows for a very compact crankcase—a significant contribution to the overall reduction in size and weight of the Mod II.

CONTROL SYSTEMS AND AUXILIARIES

The control systems and auxiliaries are not part of the basic engine but contribute significantly to the total cost of the engine system and dominate its reliability. Furthermore, analyses of the Mod II system have highlighted the importance of these components to the transient response of the engine and their impact on fuel economy. The controls and auxiliaries of the Mod II incorporate the most recent advances in this technology. The advanced design of these

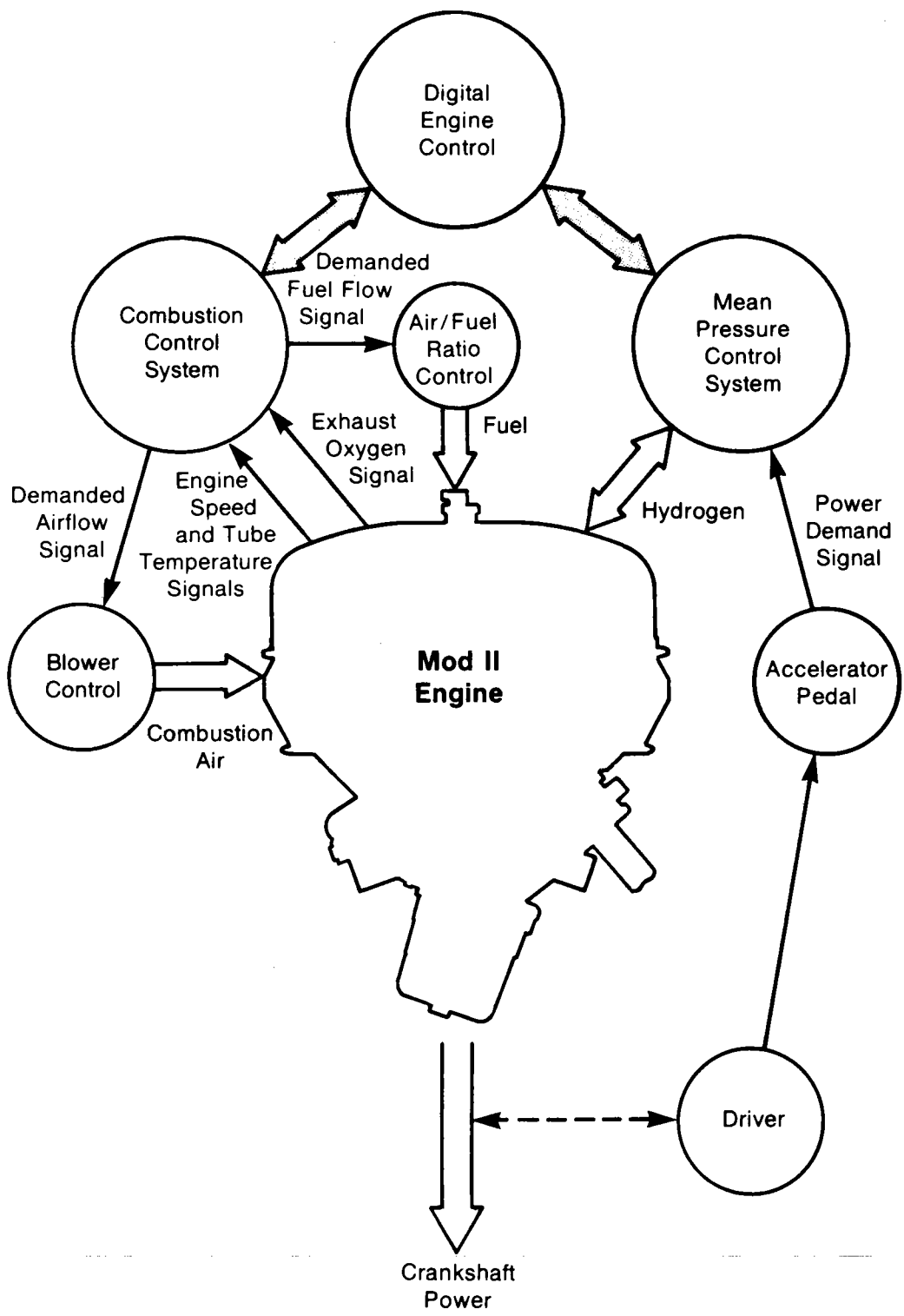

ENGINE CONTROL SYSTEMS

components has, to a large extent, enabled the Mod II to achieve projected fuel economy superior to that of the spark ignition engine.

The engine control systems consist of the digital engine control system, the combustion control system, and the mean pressure control system. Auxiliaries include the combustion air blower, alternator, fuel atomizing air compressor, fuel pump, and starter.

The logic followed in controlling engine power can best be understood by the following example. When the accelerator pedal is depressed to call for more power, the digital engine control senses this change and commands an increase in hydrogen pressure within the closed Stirling cycle. The mean pressure control system then admits pressurized hydrogen into the engine. The resulting stronger pressure wave produces higher engine torque and an acceleration to a higher crankshaft speed. Speed and pressure sensors inform the digital engine control of these increases. Since more heat is being extracted from the engine, the heater head temperature drops. The digital engine control then increases the combustion air blower speed and thus airflow to return heater head tube temperature to its set point. An airflow meter continuously informs the digital engine control of the new airflow rate. The digital air/fuel control converts the airflow rate into a desired fuel flow to be proportioned into the combustor.

A reduction in engine power starts with a transfer of hydrogen from the engine cycle to the hydrogen storage tanks. To reach idle condition, an engine-driven hydrogen compressor is required to pump from the low engine pressure to the higher tank pressure. During this pump-down period, engine power in excess of that desired is dissipated by short-circuiting hydrogen flow from the maximum pressure point to the minimum pressure point of the Stirling cycle.

Digital Engine Control System

The digital engine control contains the logic required to operate the engine. It controls all engine components so that steady-state and transient operation is comparable to that of a spark ignition engine. These control functions include communications, data storage and manipulation, as well as various check and guard procedures.

Sensors measure engine data and feed it to the digital engine control, which determines and implements the appropriate response. The digital engine control communicates with the driver via dashboard indicator lights. For example, a "recommended drive"

light flashes during the start-up sequence and goes out when the engine reaches a drive-away condition.

The digital engine control components are located in the engine compartment and under the dashboard. All inputs originate in the engine compartment and are wired directly to the digital engine control through the fire wall. All outputs originate in the digital engine control and are wired to their respective final control elements in the engine compartment and on the dashboard. The keyswitch on the steering column turns the digital engine control system on and off and starts and stops the engine.

Combustion Control System

External combustion gives a Stirling engine combustion control dynamics that are different from those of a spark ignition engine. For example, the air and fuel flow rates of a spark ignition engine are manipulated to directly control torque output. However, in a Stirling engine, the hydrogen mean pressure is used for that function, while air and fuel flows are varied to maintain heater head tube temperature at the set point. As engine speed or pressure are varied, the hydrogen inside the tubes will absorb more or less heat and the tube metal temperature will tend to rise or fall. To maintain the tube metal temperature constant, the air and fuel flows are varied to provide more or less energy for combustion.

The combustion control system consists of two major subsystems: heater head temperature control and air/fuel ratio control. Separate logic modules of the digital engine control govern these subsystems; each logic module has sensors and actuators associated with it.

The combustion control system operates as follows. Air is inducted into the system through a filter and airflow meter by a blower. From the blower, air passes through two ducts to the inlet air manifold of the external heat system. (A separate compressor provides higher pressure air for fuel atomization, which enters the engine through the fuel nozzle.) The air/fuel ratio control converts the airflow meter signal to an appropriate fuel flow demand signal. An automotive in-tank fuel pump delivers pressurized fuel to a fuel flow modulator that meters flow to the fuel nozzle, where it is sprayed into the combustor with atomizing air.

Heater Head Temperature Control. The heater head temperature control maintains the average heater head tube metal temperature at the set temperature of 820°C (1508°F). This temperature is controlled to within ±10°C (±18°F) for the severest vehicle transients. Thermocouples, located in protective sleeves on the heater head tubes, are the fundamental sensors of this control. Although other sensors implement anticipatory routines, the tube temperature thermocouples have priority in all temperature control logic.

The term PID refers to the proportional (P), integral (I), and derivative (D) modes of using the error signal ΔT , where $\Delta T = T_{\text{tube}} - T_{\text{set}}$. Each mode has its own respective gain, and all are summed together to determine a desired air blower speed. The anticipatory control, an automotive-use adjunct to the PID, is used to improve vehicle acceleration and fuel economy by preventing overshoots or undershoots in heater head temperature. The anticipatory signal input of engine speed and pressure tells the control of an impending change in power demand, before this change causes an actual change of tube temperature.

Air/Fuel Ratio Control. The air/fuel ratio control incorporates a fuel flow modulator, an airflow meter, and an oxygen sensor in the exhaust gas flow. It maintains the air/fuel ratio within ±5% of its set point during both steady-state and transient operation over the range of fuel flow from 0.15 to 5.2 g/s (1.2 to 41.4 lb/h). The actual air/fuel ratio in the combustor is determined through measurement of excess oxygen in the exhaust, which allows correction of long-term drift of the control system.

The basic air/fuel ratio control is essentially an open-loop routine, which proportions fuel flow using only the "P" mode of the PID control according to the measured airflow and the corresponding ratio. The ratio is not constant over all flow rates but is varied according to a map of air/fuel ratio versus fuel flow, determined by development testing to provide the best possible emissions and efficiency over the entire engine operating range.

Fuel flow rate is used by the control to maintain the air/fuel ratio at its set point. The fuel flow modulator consists of a pair of stock fuel injector valves and a pressure regulator. The valves are pulse-width modulated to serve as the fuel metering means. The differential pressure regulator, set at 100 kPa (15 psi), maintains a constant pressure drop across the valves to standardize the flow through the open orifice of the fuel nozzle. This keeps the pulse width-to-flow rate characterization constant.

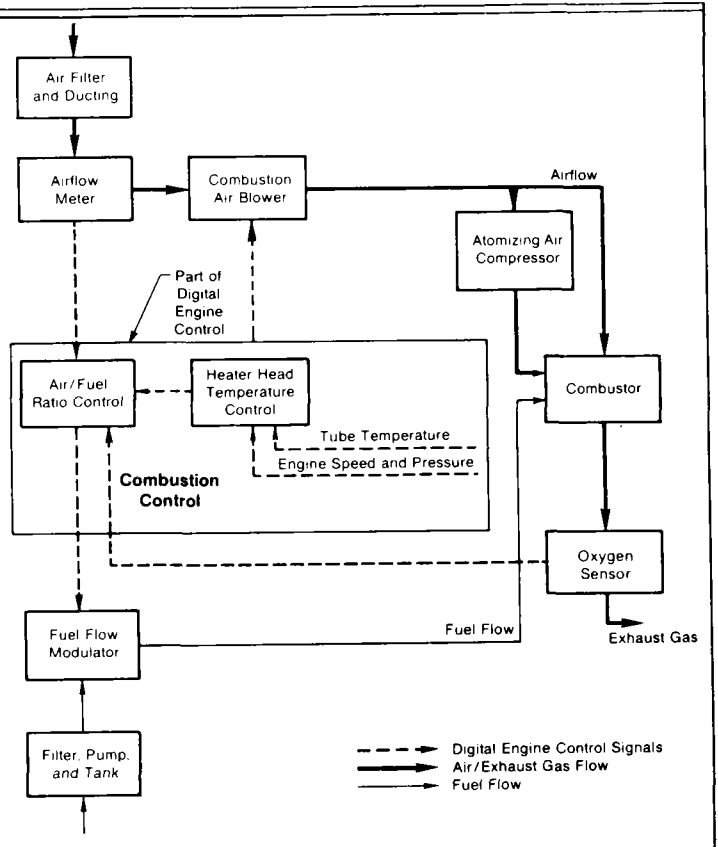

COMBUSTION CONTROL SYSTEM

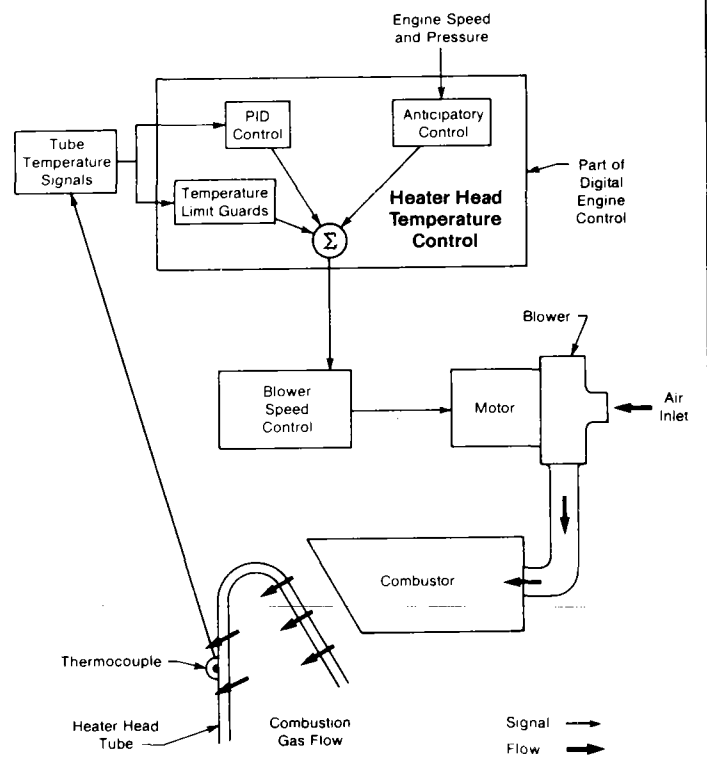

HEATER HEAD TEMPERATURE CONTROL

The airflow meter is a stock automotive hot-wire sensor that emits a signal proportional to the mass of air flowing through it.

Combustion Air Supply and Regulation

Combustion air is supplied and regulated through a fuel atomizing air supply and a combustion air supply.

Fuel Atomizing Air Supply. This auxiliary provides atomizing airflow to the fuel nozzle to break fuel droplets into a fine mist that allows rapid ignition and clean combustion. It uses a constant speed motor, driving a positive-displacement (rotary vane) compressor with a resulting near constant flow over all engine speeds and transients.

Combustion Air Supply. The combustion air supply provides air to burn fuel in the external heat system. Supply hardware consists of a three-phase permanent magnet alternator, permanent magnet brushless dc motor, and a high-efficiency combustion air blower.

The alternator serves two functions: it supplies electrical power to both the blower motor as part of the blower electrical power-transmission system and the battery for battery charging. It has two sets of windings: one for the battery or 12-V loads (1 kW (1.3 hp) maximum) and one for the blower motor load with 48- to 240-V dc bus supply (4 kW (5.4 hp) maximum). There is a 1:5 speed ratio between engine and alternator. The housing of the alternator is cooled by forced air drawn over external cooling fins.

The blower motor serves two functions: it drives the combustion air blower during normal, continuous engine operation, and it upstarts the blower during engine start. Similarly to the alternator, the blower motor has two sets of windings: one for continuous operation (meeting the duty needs of the engine with varying voltage from 48 to 240 V dc) and another designed to upstart the blower to 20,000 r/min during starts from the 12-V battery supply. Power requirements are established by the pressure drop over the external heat system.

The combustion air blower is a high-efficiency, backward-curved, centrifugal impeller blower. The airflow is split by two volutes that exit into diffusers 180° apart to allow ducting to the two inlet ducts on opposite sides of the inlet air manifold for the external heat system.

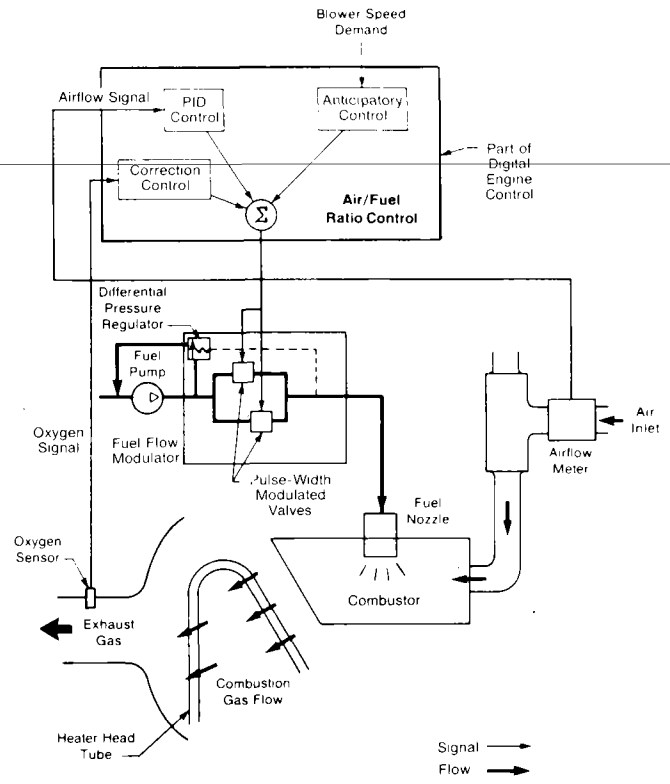

AIR/FUEL RATIO CONTROL

The pressure drop through the external heat system was used to size the combustion air blower. The blower design point is

- Maximum design speed = 43,000 r/min
- Maximum design pressure = 2950-mm water (116-in. water)
- Maximum airflow = 100 g/s (0.22 lb/s).

The result is a specific speed of 0.70 with a design efficiency of 80%.

Battery Voltage Regulator and Blower Motor Control. The power conversion electronics convert the three-phase variable frequency and amplitude outputs of the alternator for battery charging and the blower motor drive. This is done using two separate systems.

The alternator presents a variable dc voltage to the input of a pulse-width modulated voltage regulator circuit. The voltage regulator is configured as a standard stepdown switching regulator with an external shutdown input from the digital engine control to permit shedding of the battery charge and auxiliary load (approximately 1.5 kW (2 hp) mechanical) during hard acceleration. The regulator also includes a normal automotive battery temperature compensator and current limiting.

Blower Electrical Power-Transmission System

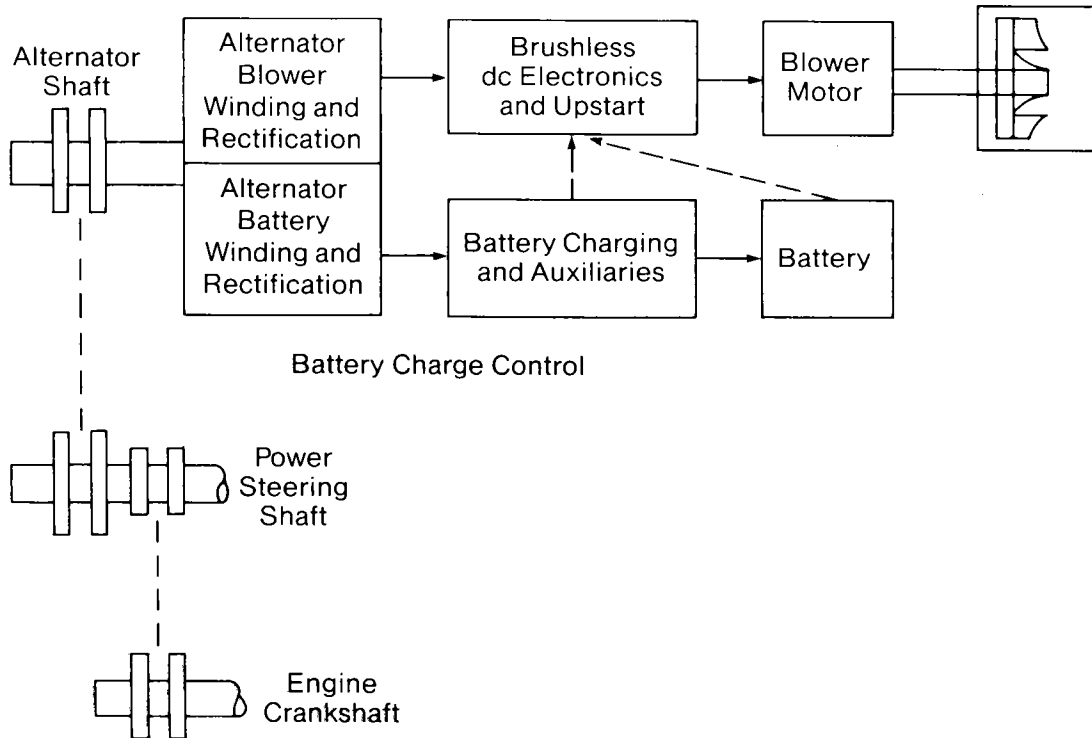

COMBUSTION AIR SUPPLY

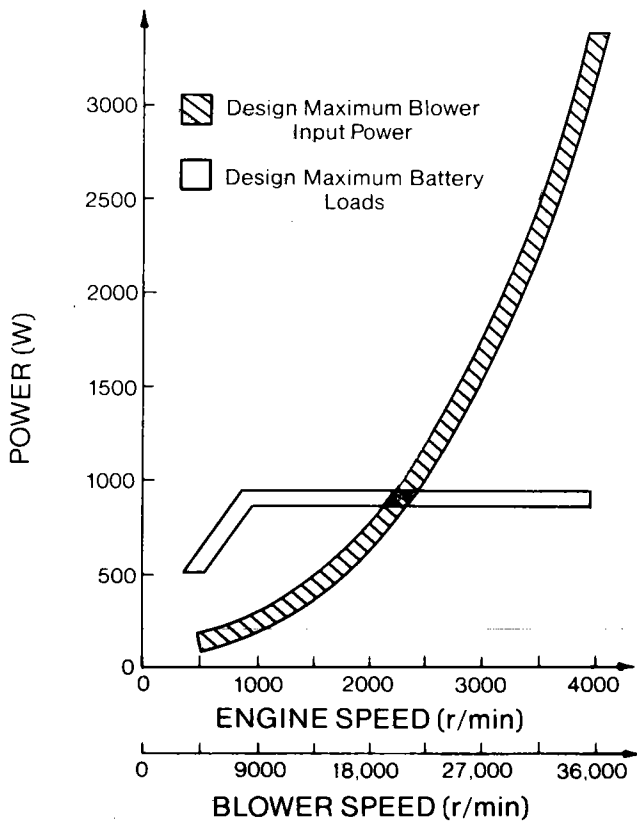



ALTERNATOR DESIGN REQUIREMENTS

The blower motor control converts the alternator output to a variable dc level by a three-phase bridge rectifier and feeds it to the blower motor. For upstart, the battery simply replaces the dc voltage supplied by the alternator.

Mean Pressure Control System

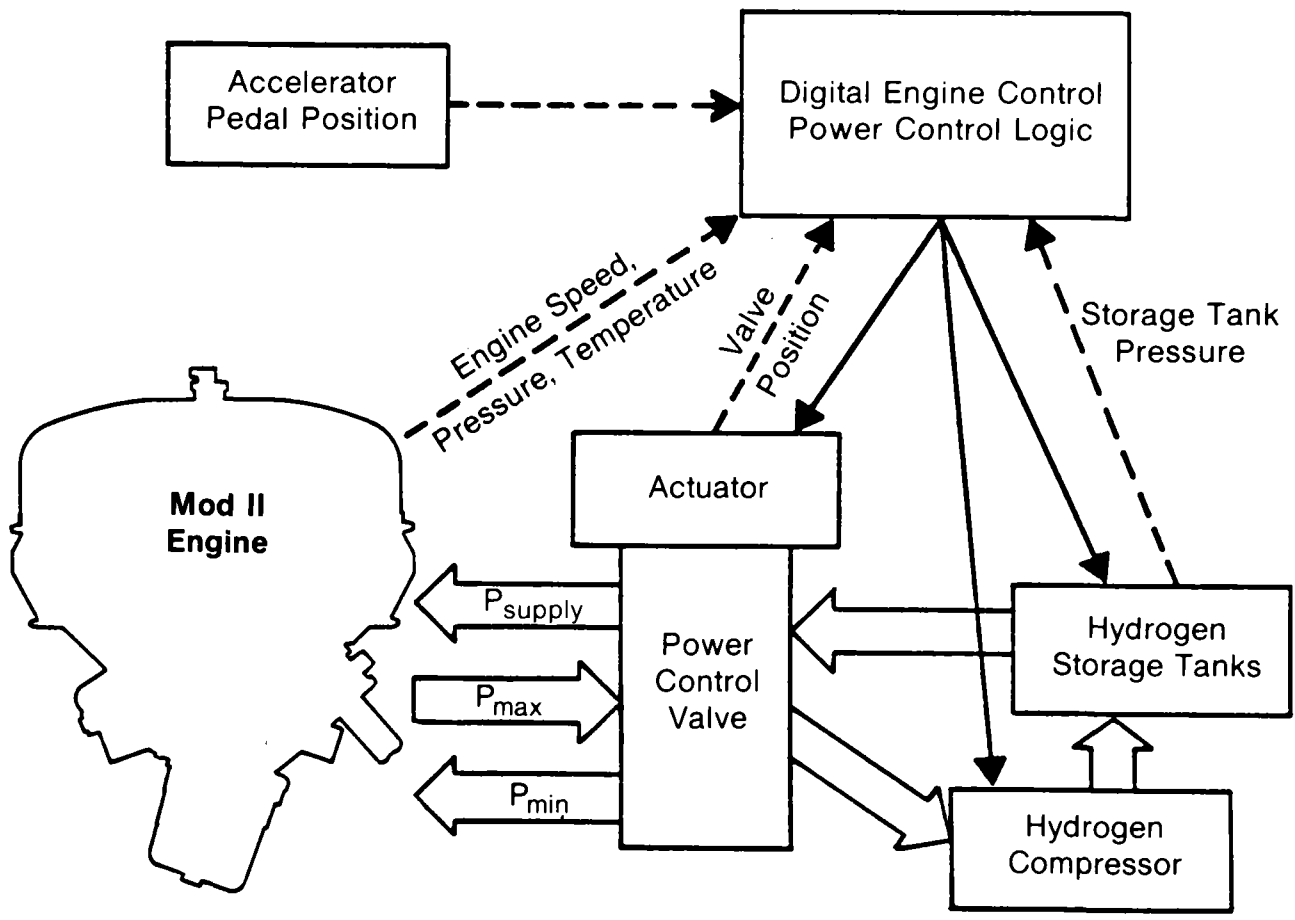
To provide drivability similar to a spark ignition engine, the Mod II uses a combination power control system consisting of mean pressure control supplemented with short-circuiting (bypass) capability. Increasing or decreasing the mean pressure within the engine to increase or decrease engine torque output provides good part-load efficiency, low idle fuel consumption, and improved engine durability due to lower average engine operating pressures. However, mean pressure control is inherently slower in response time than necessary for an automotive application. Short-circuiting control, where the maximum (P_{max}) and minimum (P_{min}) cycle pressures within the engine are directly connected or "short-circuited", provides quick response time and compensates for the slow-acting mean pressure control

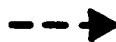

-  Sensor Output Signals to Digital Engine Control
-  Digital Engine Control Output Control Signals
-  Hydrogen Flow

MEAN PRESSURE CONTROL SYSTEM

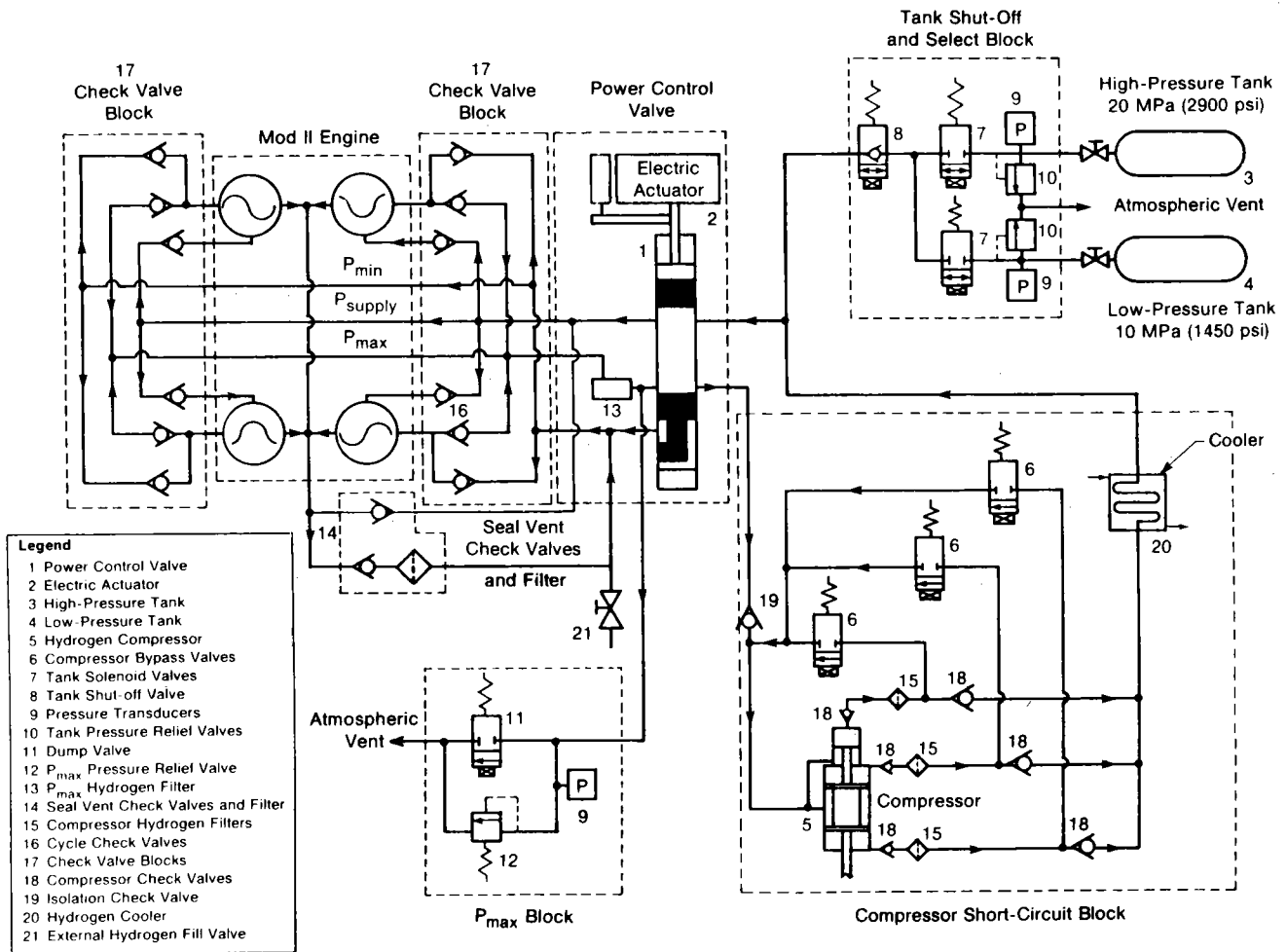

MEAN PRESSURE CONTROL SYSTEM SCHEMATIC

system during quick transients. When engine power is greater than required and hydrogen is being pumped out of the engine, short circuiting dissipates any momentary excess power and provides engine braking as required to control engine speed. Since use of short-circuiting control results in decreased efficiency, the system is optimized so that short circuiting is used as little as possible.

Mean Pressure Control System Operation. The power control valve (1)* is a sliding spool valve that regulates hydrogen flow in and out of the engine. This valve is mechanically positioned to perform four separate operating functions: supply, neutral, dump, and dump plus short circuit. (Note that these valve functions are synonymous with the valve positions.) For all operating functions except neutral, the hydrogen flow can be proportioned anywhere between 0 and 100%. An electrically driven actuator (2) moves the power control valve to provide the four operating functions based on input from the digital engine control.

In the supply position, the power control valve supplies hydrogen from the hydrogen storage tanks (3, 4) to the engine via the P_{supply} line, thus increasing engine torque. Through a mechanical timing system, hydrogen is always added to the engine at the point when pressure within the cycle is at a minimum. This preserves the engine's peak torque capability and allows smooth transition to the higher pressure. When the power control valve is in the neutral position, there is no hydrogen flow to or from the engine, and the engine is in steady-state, constant torque operation. In the dump position, hydrogen is pumped by a hydrogen compressor (5) from the engine back into the storage tanks, thus decreasing engine torque.

**Numbers in parentheses refer to the legend on the Mean Pressure Control System Schematic.*

When the compressor cannot pump fast enough to decrease engine torque by the desired amount, the power control valve moves to the dump plus short-circuit position. While the compressor continues to pump, the excess engine torque is dissipated through bypassing maximum cycle pressure to minimum cycle pressure. As the engine pressure approaches the desired lower value, the power control valve moves back through the dump position to the neutral position.

In the event of a total electrical power loss or if power to either the digital engine control or the actuator is interrupted or short-circuited, failsafe operation occurs and the power control valve is moved to the appropriate position.

The various subcomponents of the mean pressure control system are grouped into four separate blocks with specific functions: compressor short circuit block, tank shut-off and select block, P_{max} block, and check valve blocks.

The hydrogen compressor is a single-stage, multiple-volume type with three pumping volumes. Since the compressor is driven at engine speed, each of the volumes is controlled by its own electrically operated compressor bypass valve (6). When pumping is not desired, the valves are opened, bypassing the compressor output back to the input port. When pumping is desired, the valves are closed, causing the compressor volumes to pump hydrogen from the engine to the storage tanks. The valves can be opened or closed in any combination, thus tailoring the compressor pumpdown rate to other engine parameters.

Hydrogen storage consists of two 4-liter (1.1-gal) storage tanks and a tank shut-off and select block. One tank is maintained at a high pressure of 20 MPa (2900 psi), the other at 10 MPa (1450 psi). System logic directs that the engine will first be supplied from the low-pressure tank. At some intermediate pressure, the supply is switched to the high-pressure tank. Conversely, pumpdown occurs first to the high-pressure tank, then is switched to the low-pressure tank as engine pressure falls. By keeping the tank pressure "close" to engine pressure, the required compressor pressure ratio is kept below three to one, thus avoiding the need for a two-stage compressor.

The tank shut-off and select block contains two solenoid valves (7) to control which tank is in use; a third solenoid valve (8) to allow tight shut-off of the hydrogen supply system; two pressure transducers

(9) to provide pressure data to the digital engine control; and two pressure relief valves (10) to protect the storage tanks from overpressure.

The P_{max} block houses a pressure transducer (9) to provide pressure information to the digital engine control; a dump valve (11) to vent hydrogen from the engine to atmosphere; and a pressure relief valve (12) to protect the engine from overpressure. If necessary, the dump valve is operated from either a dashboard-mounted switch or by the digital engine control logic.

Five hydrogen filters (13, 14, 15) remove any dirt or contamination from the mean pressure control system. Because the system contains only dry hydrogen, the various seals and piston rings are susceptible to foreign material damage and filtration is important. The seal vent filter (14) is also designed to remove oil vapor and droplets from the system.

A total of 21 check valves control the hydrogen flow within the system. Twelve of these (three per cycle) (16) are mounted in two check valve blocks (17). These control the supply of hydrogen into the cylinders and the short-circuiting flow. Six more check valves (18) control the flow within the hydrogen compressor, and one (19) isolates the compressor from the power control valve. The seal vent check valves (14) return any hydrogen that has entered the seal housing cavities to the system.

A cooler (20) is mounted downstream of the hydrogen compressor. This device uses engine cooling water to cool the compressed hydrogen before returning it to the storage tanks.

An external hydrogen fill valve (21) allows recharging of the system with hydrogen to compensate for the small amount of leakage that may occur over extended periods. The vehicle system specification calls for hydrogen recharge every six months.

The hydrogen plumbing is all rigid tubing with the exception of a single flexible line from the hydrogen compressor cooler to the tank shut-off and select block.

CONCLUSIONS

The ASE program goals to develop an alternative automotive engine and to transfer Stirling technology to the United States have been achieved by the Mod II. The Mod II reflects the advancements made in Stirling technology and represents a competitive alternative power plant that has evolved from a laboratory curiosity to a viable engine ready for prototype or preproduction engineering.

The success of the Mod II design can be attributed to several factors, including such diverse elements as a systems approach to the design effort and the use of nonstrategic materials. Perhaps the most significant of these is the compact simplicity of the engine design. The number of parts has been reduced, with a corresponding reduction in engine weight and cost. In turn, reducing the size of the Mod II facilitates its packaging in a front-wheel-drive vehicle. Simplification of the engine controls not only makes the Mod II lighter but more responsive, leading to improved acceleration characteristics. Another key design feature contributing to the overall compactness of the Mod II is the annular design of the engine cylinders.

The conduct of the ASE program and its success in achieving the program goals are testimony to the excellence of a cooperative team of government and industry personnel as documented in Appendix D.

Through the ASE program, the United States has attained international leadership in Stirling engine technology—technology that can be readily applied to applications beyond the automotive field. To continue this leadership role, the advances made through the ASE program should not remain static but rather become the basis for future challenge and success.

APPENDIX A

CHEVROLET CELEBRITY SPECIFICATION

The following presents the specification for the Mod II-powered Celebrity.

Except where noted, the specifications for the spark ignition and Mod II engines are identical.

General Vehicle Description

Model Year	1985 4-Door Notchback, Chevrolet Celebrity
EPA Car Class	Midsize
Maximum Passengers	2 Front/3 Rear

Engine Specifications

	<u>Spark Ignition</u>	<u>Mod II</u>
Type	Inline 4	V4
Displacement, L (in. ³)	2.5 (151)	0.502 (30.3)
Power, kW (hp)	69 (92) at 4800 r/min	62.3 (83.5) at 4000 r/min
Torque, N·m (ft·lb)	182 (134) at 2800 r/min	212.2 (156.5) at 1000 r/min

Vehicle Weights

	<u>Spark Ignition</u>	<u>Mod II</u>
Curb Weight* kg (lb)	1251.7 (2760)	1297.1 (2860)
Gross Vehicle Weight, kg (lb)	1740.6 (3838)	1740.6 (3838)
Distribution, kg (lb)		
Front	788.2 (1738)	833.6 (1838)
Rear	463.5 (1022)	463.5 (1022)
Test Weight, kg (lb)	1387.8 (3060)	1433.1 (3160)
Equivalent Test Weight (EPA Inertia Weight), kg (lb)	1361 (3000)	1417 (3125)

* Includes weight of air-conditioning package.

Celebrity Fuel Economy

	<u>Spark Ignition</u>	<u>Mod II</u>
Urban without Cold-Start Penalty, km/L (mi/gal)	11.6 (27.2)	17.5 (41)
Cold-Start Penalty, g (oz)	37* (1.3)	125 (4.4)
Urban, km/L (mi/gal)	11.1 (26)	14.1 (33)
Highway, km/L (mi/gal)	17.1 (40)	24.7 (58)
Combined Mileage, km/L (mi/gal)	13.2 (31)	17.5 (41)

* See Appendix C.

Celebrity Acceleration

	<u>Spark Ignition</u>	<u>Mod II</u>
0-97 km/h (0-60 mi/h), s	13.0	12.4
81-113 km/h (50-70 mi/h), s	—	10.5
0-30 m (0-100 ft), s	—	4.1
Gradeability, %	30	30

Celebrity Road Load

Tire Type	P185/75R-14
Rolling Resistance* Coefficient (Force/Vehicle Test Weight)	0.0089 (Road) 0.0091 (Dynamometer)
Rolling Radius, mm (ft)	306.6 (1.006)
Revolutions Per Mile at 72.4 km/h (45 mi/h)	835
Air Drag at 20°C (68°F), 97.9 kPa (14.2 psi), kW at 80.4 km/h (hp at 50 mi/h)	4.981 (6.69)
Drag Coefficient	0.380
Frontal Area, m ² (ft ²)	2.02 (21.69)

	<u>Spark Ignition</u>	<u>Mod II</u>
Total Road Load, kW at 80.4 km/h (hp at 50 mi/h)	7.718 (10.35)	7.867 (10.55)
EPA Dynamometer Actual Road Load**, kW at 80.4 km/h (hp at 50 mi/h)	5.414 (7.26)	

* Assumed constant over range of operation.

** Includes EPA compensation for air conditioning.

Celebrity Drive Train

Axle	Front-Wheel Ring and Pinion Drive	
Drive Method	Spark Ignition	Mod II
Final Drive Ratio	3.65:1	2.66:1
Transmission*	4-Speed Manual Transmission	
Type		
Gear Ratio—	First 3.53	Second 1.95
	Third 1.24	Fourth 0.81

* Note that the desired transmission for this application would be an automatically shifted manual transmission with no torque converter. The high torque output of the Stirling engine at low speed eliminates the need for the torque converter, resulting in decreased drivetrain losses. Development of such a transmission was beyond the scope of the ASE program, so the manual transmission was selected.

Celebrity Accessory Load

Type	Power Steering, Alternator
Alternator (Peak Demand), kW (hp)	4.3 (5.8)
Average Load over EPA Driving Cycle, kW (hp)	1.0 (1.3)
Air-Conditioner Power	10% of Dynamometer Power Setting

Operating Envelope

Start and Operate under the Following Conditions:
 Temperature -29°C/46°C (-20°F/115°F)

Mod II Start-Up and Shutdown

Maximum External Electrical Energy Required For Start

20°C (68°F),
 97.9 kPa (14.2 psi) 500,000 J

-28.9°C (-20°F),
 97.9 kPa (14.2 psi) 1,500,000 J

Maximum Starting Time (Key On Until Power Available), s

20°C (68°F),
 97.9 kPa (14.2 psi) 30

-28.9°C (-20°F),
 at 4267 m (14,000 ft) 40

Maximum Shutdown Time, s

Stable Idling Condition,
 Sea Level, 20°C (68°F) 120

Mod II Emissions

EPA Emissions Test at 80,450 km (50,000 mi)

NO _x , g/km (g/mi)	≤0.249 (≤0.4)
HC, g/km (g/mi)	≤0.255 (≤0.41)
CO, g/km (g/mi)	≤2.11 (≤3.4)
Particulates, g/km (g/mi)	≤0.124 (≤0.2)

APPENDIX B

MOD II ENGINE SPECIFICATION

MOD II Engine Performance Characteristics

Performance Breakdown in Five Operating Points

Full Load Point (p = 15 MPa (2175 psi), n = 4000 r/min)

Indicated Power, kW (hp)	78.6	(105.4)
Friction, kW (hp)	9.9	(13.3)
Auxiliaries, kW (hp)	6.4	(8.6)
Net Power, kW (hp)	62.3	(83.5)
External Heat System Efficiency, %	88.9	
Net Efficiency, %	28.2	

Part Load Point (p = 12 MPa (16.1 hp), n = 2000 r/min)

Indicated Power, kW (hp)	15.7	(21.1)
Friction, kW (hp)	2.0	(2.7)
Auxiliaries, kW (hp)	1.6	(2.15)
Net Power, kW (hp)	12.0	(16.1)
External Heat System Efficiency, %	90.4	
Net Efficiency, %	33.2	

Maximum Efficiency Point (p = 15 MPa (2175 psi), n = 1200 r/min)

Indicated Power, kW (hp)	30.4	(40.8)
Friction, kW (hp)	2.5	(3.4)
Auxiliaries, kW (hp)	1.3	(1.7)
Net Power, kW (hp)	26.7	(35.8)
External Heat System Efficiency, %	91.0	
Net Efficiency, %	38.5	

Low Load Point (p = 5 MPa (725 psi), n = 1000 r/min)

Indicated Power, kW (hp)	9.1	(12.2)
Friction, kW (hp)	0.9	(1.2)
Auxiliaries, kW (hp)	1.0	(1.3)
Net Power, kW (hp)	7.1	(9.5)
External Heat System Efficiency, %	88.8	
Net Efficiency, %	32.3	

Idle Point (p = 2 MPa (290 psi), n = 400 r/min)

Net Power, kW (hp)	0.5	(0.7)
Net Efficiency, %	8.0	
Fuel Flow, g/s (lb/min)	0.159	(0.021)

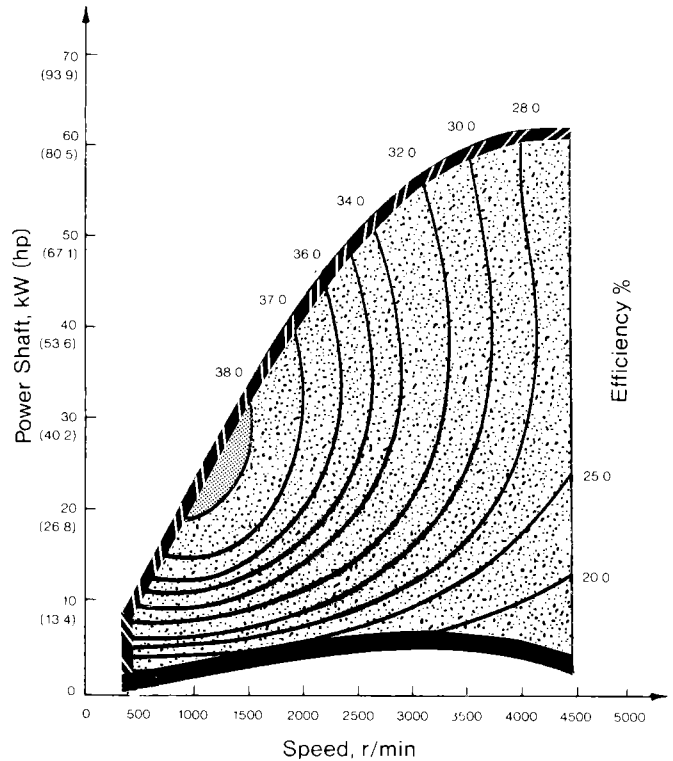

- Maximum Power Curve
- Minimum-Power Operating Line
- Region of Maximum Efficiency
- Lines of Constant Efficiency

MOD II ENGINE PERFORMANCE MAP

APPENDIX C

FUEL ECONOMY AND PERFORMANCE CALCULATIONS

The complete EPA urban driving schedule consists of two identical cycles run with different starting conditions. The first cycle begins after the engine (not running) and car have attained thermal equilibrium at room temperature. This is defined as a "cold start." As a heat engine, the Stirling engine differs from the spark ignition engine in that more fuel energy is required to heat certain parts of the engine to their respective operating temperatures. This extra fuel consumption, known as the cold-start fuel consumption (CSFC), is directly related to the mass of the engine components that attain a hot temperature during operation. The Mod II has a stored energy of 10.9 MJ (10,331 Btu), which translates into a cold-start fuel consumption of 254 g (9 oz). This fuel consumption penalty is unique to a Stirling engine and is not applied to a spark ignition engine.*

The second cycle follows after a 10-min "hot-soak" phase that occurs with the engine stopped and results in a small energy loss. Upon start-up, this lost energy must be replaced into the hot parts, resulting in a hot-start fuel consumption (HSFC) of 28 g (1 oz) for the Stirling engine.

The EPA assumes that 43% of all vehicle starts will be cold starts and that the remaining 57% will consist of hot starts. The EPA test procedures for the urban driving schedule weight these cold-start and hot-start fuel consumptions to determine a single, combined fuel consumption known as the cold-start penalty (CSP), i.e.,

$$\text{CSP} = 0.43(\text{CSFC}) + 0.57(\text{HSFC}).$$

Hence, the cold-start penalty for the Mod II is

$$0.43(254) + 0.57(28) = 125 \text{ g (4.4 oz)}.$$

Because the entire EPA highway schedule is run with a fully stabilized engine, no start-up fuel consumption penalty is needed. This cold-start penalty has been incorporated in the mileage values quoted in this report. Note that all calculations are made using unleaded gasoline.

* During the ASE program, testing on the spark ignition-powered Celebrity to determine cold-start fuel consumption proved inconclusive. However, the best assessment of the test data indicated that the cold-start fuel consumption of the spark ignition-powered Celebrity is 60 g (2.1 oz) and the hot-start fuel consumption is 20 g (0.7 oz), leading to a cold-start penalty of 37 g (1.3 oz).

APPENDIX D

THE AUTOMOTIVE STIRLING ENGINE DEVELOPMENT PROGRAM

As established on 25 February 1978, Title III of Public Law 95-238, the Automotive Propulsion Research and Development Act, directed the Secretary of Energy to create new programs and to accelerate existing ones within the Department of Energy (DOE) to ensure the development of advanced automotive engines. The act was based on congressional findings that existing automotive engines failed to meet the nation's long-term goals for energy conservation and environmental protection. Similar congressional findings established that advanced, alternative automotive engines could, given sufficient research and development, meet these goals and offer potential for mass production at a reasonable cost.

To this end, Congress authorized an expanded research and development effort to advance automotive engine technologies such as the Stirling cycle. The intent was to complement and stimulate corresponding efforts in the private sector and, in turn, encourage automotive manufacturers to seriously consider incorporating such technology into their products. The Automotive Stirling Engine (ASE) Development Program evolved from this legislation. The program began at Mechanical Technology Incorporated (MTI) in Latham, New York, on 23 March 1978. Funding was provided by DOE and administration by the National Aeronautics and Space Administration Lewis Research Center (NASA-LeRC), Cleveland, Ohio, under Contract DEN3-32.

The ASE program set out to meet a substantial challenge—the successful integration of a Stirling engine into an automobile with acceptable drivability. At the outset of the program, the main objectives were to develop an automotive Stirling engine and to transfer European Stirling engine technology to the United States. These generic goals have remained constant, as did a program approach focusing on concurrent engine and component development efforts.

Stirling engine technology has been significantly advanced by the ASE program. To understand a program of this scope and achievement requires initiation into the program history, as well as into the terminology created throughout the course of the program. This appendix attempts to provide that initiation and begins by documenting how changes in the program plan influenced the technology development.

THE ASE PROGRAM PLAN

The original ASE program organization included three team members: MTI, United Stirling AB (USAB) of Sweden, and AM General, which was at that time a wholly owned subsidiary of American Motors Corporation. The addition of a fourth team member, a U.S. engine manufacturer, was planned for later in the program. This manufacturer potentially would contribute design, development, and manufacture capabilities within the United States, as well as become the recipient of the technology transferred in the program. Selection of the team was based on the program management and technology development skills of MTI as prime contractor and on the extensive background in Stirling engine technology provided by USAB. AM General was responsible for vehicle selection, integration, application, and evaluation.

USAB provided the initial infusion of technology and a baseline engine, the P-40, an engine with 40-kW (53.6-hp) maximum power. Although the Stirling cycle dates from 1816, substantial research in engines based on this cycle had occurred only in the past few decades. Moreover, most Stirling engine technology resided outside the United States and was aimed at stationary and marine applications. This work had been done at the N.V. Philips Electric Company in Eindhoven, Netherlands, and at USAB in Malmö, Sweden, a licensee of Philips since 1968. Since a major portion of the world's Stirling engine technology resided with USAB at the beginning of the program, their participation was essential to successfully effect the technology transfer to the United States.

The initial performance objectives were to develop an automotive Stirling engine that, when installed in an American-manufactured automobile, would

- Demonstrate at least a 30% improvement in EPA combined urban/highway fuel economy (based on EPA test procedures) over a comparable 1977 spark ignition production vehicle.
- Show the potential for emission levels (after 80,450 km (50,000 mi)) of
 - $\text{NO}_x \leq 0.249 \text{ g/km}$ ($\leq 0.4 \text{ g/mi}$)
 - $\text{HC} \leq 0.255 \text{ g/km}$ ($\leq 0.41 \text{ g/mi}$)
 - $\text{CO} \leq 2.11 \text{ g/km}$ ($\leq 3.4 \text{ g/mi}$)
 - $\leq 0.124 \text{ g/km}$ ($\leq 0.2 \text{ g/mi}$) (total particulate level).

Additional engine system design objectives included

- Reliability/life comparable to current market power trains
- Initial and life-cycle costs competitive with a conventionally powered automotive vehicle
- Noise/safety characteristics to meet 1984 Federal standards.

Throughout the ASE program, changes in the program plan arose as part of the "natural order" of government-sponsored research. These changes are most easily categorized into four time periods, the first of which covers the initial 17 months of the program.

Original Program Plan: March 1978 to July 1979

The original program plan involved nine tasks and called for the development/manufacture/test of 46 Stirling engines; 35 of these would undergo dynamometer testing and 11 would be installed and tested in vehicles. Early program efforts were devoted to initiating the Reference engine design, a "paper" engine used to guide component and engine development efforts, as well as establishing the facilities and staff necessary to conduct a program of this scope.

ASE Program Revisions: July 1979 to September 1981

The original program plan was restructured in July 1979 to comply with new NASA/DOE mandated restrictions. Several aspects of the program changed as the result of these provisions. First, the program goals were modified in that the fuel economy goal was upgraded to be 30% greater than a comparable 1983 spark ignition production vehicle. Although the emissions goals remained the same, the

engine goal now was to demonstrate multifuel capability. Second, the program scope was narrowed from three engine generations to two, and the terms "Mod I" and "Mod II" were assigned to the first and second engine generations. In addition, the number of engines to be manufactured was reduced from 38 to 17, while the number of vehicles was reduced from 10 to 7.

ASE Proof-of-Concept Program: September 1981 to May 1983

The program proceeded without modification until the last quarter of fiscal year 1981, when extensive funding cutbacks forced the postponement of the Mod II design and its associated development efforts. By this point in time, Mod I engines were testing and had successfully demonstrated engine peak efficiencies of greater than 34%. Because the Reference engine embodied the technologies and design concepts that would have culminated in a Mod II, it was reasoned that existing Mod I engine hardware could be used to develop and demonstrate those technologies that were not initially in the Mod I but were embodied in the Reference engine. Hence, the proof-of-concept program emerged. Under this new plan, a technology demonstration would be accomplished through a series of upgraded Mod I designs.

No other significant changes occurred in the ASE program until the initiation of the Industrial Test and Evaluation Program in March 1983. By this time, four Mod I engines had successfully tested for greater than 2000 hours.

Three companies participated in the Industrial Test and Evaluation Program: General Motors, John Deere and Co., and the Cummins Engine Company. The intent of this program was threefold: 1) to provide an independent evaluation of the technology level of the ASE program, 2) to establish a forum for U.S. automotive and/or engine manufacturers to input their recommendations relative to improving the design and manufacturability of Stirling engines, and 3) to provide a larger engine test base from which Stirling engine performance and durability could be assessed.

Mod II Reinitiated: May 1983 to September 1987

In May 1983, funding was restored to a level that permitted reinitiation of the Mod II design. Several former program milestones were reincorporated in the program schedule.

- The Mod II basic engine and engine system design reviews were scheduled for April 1985 and August 1985, respectively
- The Mod II engine test was scheduled for March 1986
- The program objectives were to be demonstrated by September 1987.

With the advent of the Mod II, the program entered a transitional phase, as the emphasis in development and the application of resources shifted from the Mod I to the Mod II.

ASE TECHNOLOGY DEVELOPMENT

Advancements made in Stirling engine technology by the ASE program can best be measured by describing the design concepts of the actual engines. These included four classes: the Reference engine, the P-40, the Mod I, and the Mod II. While interrelated to some extent, each engine had distinct objectives and achievements and thus warrants separate discussion. Throughout the program, regardless of what engine system was being designed or developed, a comprehensive component development program was active. The component development activities at any given time were dictated by the Reference engine and successful advances were reflected in the hardware of the various engine designs.

The Reference Engine System Design

As the focal point for all engine development, a Reference engine system design was established. This reference design is a "paper" engine and represents that Stirling engine providing the best fuel economy, while also meeting or exceeding the ASE program objectives. In effect, the Mod I and Mod II engines were experimental models of the Reference engine.

Throughout the course of the program, the Reference engine evolved as technology improvements were achieved and subsequently incorporated in its design. The earlier Reference engines were closely related to the P-40 and the Mod I, with a two-shaft, U-drive system. Their modular construction, although ideal for component testing, required extensive, costly fabrication and sensitive assembly that was inappropriate for a production engine. Further, the trend in vehicle systems was toward a considerable downscale in curb weights, reducing the available volume under the hood to package an engine. In response to this growing concern over the Stirling engine's packageability in small-size vehicles, the engine design began to focus on reducing manufacturing cost and a downsized engine.

Accordingly, the Reference engine was revised in May 1983, marking a major departure from earlier Reference engines designed primarily for maximum efficiency. This design review was a crucial program milestone and brought a new emphasis on improving cost and manufacturability. The most dramatic change was from the two-shaft, U-drive system to the single-shaft, V-drive system. Another notable change was a single-piece engine block in place of the multiple case design.

After thorough performance and cost analyses, the 1983 Reference engine was proven competitive with spark ignition engines and subsequently adopted as the basis for an improved engine system. This provided the impetus to initiate the Mod II engine design and development.

Component Development

Component development was the most crucial and vital aspect of the total engine development effort. The objective of this task was to advance Stirling engine technology with an emphasis on cost, performance, and design simplicity. All activities were directed at developing combustion technology, heat exchangers, seals, control systems, electronics, auxiliaries, and the subsystems necessary to integrate these components into the engine design. Through conceptual design and analysis to actual hardware fabrication, instrumentation, assembly, and test, the component development effort became, in effect, the proving ground for the design concepts and technologies of the Reference engine. All activity was guided by the design of the Reference engine and the technology improvement required to meet its performance objectives. Extensive testing focused on specialized rig, integrated engine performance

and endurance, and vehicle system transient evaluations. New design concepts were evaluated in exploratory test rigs and then moved to more complex rigs before actual engine testing.

The first component rig test occurred at MTI in 1980 and over 25 specialized component rigs were used throughout the course of the program. These included a free-burning combustor rig, regenerator heat transfer rig, materials screening test rig, reciprocating wear test rig, and combustor endurance and performance test rigs. In addition, the P-40 and Mod I engines were used as experimental operating hardware to evaluate component development concepts. The engine/vehicle system served as the final test environment, where the interaction of system upon system was observed and where the transient effects of the vehicle system on performance and life were determined.

The contributions made by the component development task to the ASE program should not be understated; the broad range of technologies addressed through this effort are outlined below.

- Combustion Technology—fuel nozzle, emission control systems, soot control, alternative fuels, transient air/fuel control systems development
- Heat Transfer Technology—heater head, regenerator, and preheater development
- Mechanical Component and Drive System Technology—main sliding seals, piston rings, and engine drive system components, such as bearings
- Materials and Material Processes—investigating replacements for high-cost strategic materials used in the heater head; processes for brazing, welding, casting, and ceramics were also investigated
- Controls—advancing the technology level of the power control system, developing electronic controls, and studying alternative concepts of control to reduce cost and complexity and improve reliability
- Auxiliaries—combustion air blower and hydrogen compressor development and numerous electric drive motors to eliminate need for hydromechanical drive systems.

P-40 Engine: The Baseline

Technology transfer in the program began with the USAB P-40 engine, a kinematic engine with four double-acting pistons and two crankshafts geared to a third output shaft. A heavy engine originally designed for laboratory use, the P-40 was underpowered for the automotive application. However, in 1978, it represented an existing engine system that offered an ideal baseline for Stirling engine technology familiarization. By providing engine test experience, vehicle integration experience, and data on vehicle performance, the P-40 engine gave U.S. team members the opportunity to observe Stirling engine characteristics and transient behavior. Of the P-40 engines manufactured and assembled by USAB, three of these merit particular mention for their program contributions.

- Engine No. 4 was designated the High-Temperature P-40 (HT P40) endurance engine and used extensively for materials life testing at heater head metal temperatures of 720°C (1328°F) and 820°C (1508°F).
- Engine No. 5 was installed in a GM Opel car. It provided valuable experience in the area of engine/vehicle integration.
- Engine No. 7 was delivered to MTI in April 1979. This engine provided MTI engineers and technicians with valuable, hands-on experience in the complete disassembly/reassembly and test of a Stirling engine.

The Mod I

The Mod I effort addressed a new, first generation automotive Stirling engine. Designed and built to provide more complete workhorse system capabilities, the Mod I aimed at providing additional test capability as early in the program as possible and reflected the use of automotive engineering design and fabrication techniques.

The Mod I was the first engine designed for the automotive application with definitive goals to reduce specific weight and specific volume while providing exceptional performance. The overall aim of the Mod I was to achieve maximum engine performance consistent with the current proven technology. As the first generation automotive engine, the Mod I represented a composite of early program efforts in component development and baseline engine technology. The design was four cylinders, with two crankshafts and a single output shaft similar in basic concept to the P-40 engine. Its maximum predicted power at 4000 r/min was 50 kW (67 hp).

The preliminary Mod I design assessment review among program personnel was held in November 1979 and the final design review occurred in May 1980. Drive system motoring tests of the first Mod I engine began in October 1980; but testing of the basic engine started in January 1981 and engine system testing began in April 1981. Engine No. 1 was fully characterized by September 1981 and demonstrated a peak measured power of 53.9 kW (72.3 hp) at 4000 r/min and a measured efficiency of 37.4% at 1500 r/min versus the levels predicted in 1980 of 50 kW (67 hp) and 37.7%, respectively.

Although the family of engines is referred to as Mod I, there were actually two major divisions within this configuration: the Mod I and upgraded Mod I. In 1981, program funds were reduced and the Mod II engine design was postponed, making the Mod I the only active experimental engine. Under the proof-of-concept program, the Mod I was modified to develop and demonstrate certain new technologies called for in the Reference engine that were to have been incorporated in the Mod II. The "upgraded" Mod I engine emerged in February 1983 as an evolutionary improvement over the Mod I.

This course of action had inherent limitations, since Mod I hardware was larger and, in some cases, designed differently than the Reference engine. Nevertheless, important upgrades were made to the Mod I, which provided valuable feedback. These upgrades included reductions in weight and size, different heater head materials to reduce the amount of strategic metals, and a cycle design specifically optimized for the part-load operation that dominates automotive usage. In addition, its operating temperature was raised from 720°C (1328°F) to 820°C (1508°F) as called for in the Reference engine. This resulted in upgraded Mod I measured power levels of 63 kW (84 hp) and peak efficiency values of 39%.

Ten Mod I or upgraded Mod I engines were built and tested throughout the program. Each made particular contributions to Stirling technology; these contributions are outlined below.

Engine No. 1, the Vehicle Installation Engine, was configured as a Mod I engine system and installed in an AMC Lerma vehicle in May 1982 to evaluate control, emissions, and fuel economy performance. The Lerma vehicle had a Chrysler wide-ratio, 3-speed automatic transmission with lockup, a 2.73-rear-axle ratio, power steering, power brakes,

and an inertia weight of 1701 kg (3750 lb). With air conditioning, it required an 8.3-kW (11.1-hp) road load at 81 km/h (50 mi/h).

Engine No. 2 was designated as a development engine to verify Mod I performance. Configured as a basic engine, this engine underwent testing at USAB.

Engine No. 3, designated the Endurance Engine, was subjected to an accelerated duty test cycle. The duty test cycle, based on data from the Urban/Highway Driving Cycle, was designed to be more severe than normal driving conditions and included

- 100 starts and stops (25 with the engine cold and 75 with the engine warm)
- 1000 hours of endurance according to a duty test cycle.

This test program demonstrated the outstanding Stirling-cycle and seal durability of the Mod I and initiated several redesigns that were eventually incorporated in the upgraded Mod I.

Engine No. 4 was manufactured in the United States and assembled at MTI; it clearly demonstrated the level of Stirling engine technology transfer to the United States. More than 30 U.S. vendors participated during the procurement phase of Engine No. 4. This engine was tested at MTI as an engine system. It was then reconfigured as an upgraded Mod I, designated Engine No. 5, and used extensively to measure heater head tube temperatures. Engine No. 6, also configured as an upgraded Mod I, was tested as a basic engine to evaluate engine performance.

Engine No. 7, configured as a Mod I, was used for main seal life testing and accumulated numerous test hours according to a prescribed duty cycle. By means of an automatic control, this engine was tested 24 hours a day, 7 days a week, and provided valuable life data on not only seal components but all engine parts.

Engine No. 8, an upgraded Mod I, was used in the Industrial Test and Evaluation Program. This engine was installed in an AMC Spirit and delivered to General Motors Research Laboratories in April 1984,

where it accumulated 1745 km (1082 miles). The GM test program involved severe wind tunnel testing at ambient temperatures to 49°C (120°F) with high engine loads, as well as chassis dynamometer tests and test track runs. Only minor problems were experienced, with the engine exhibiting excellent durability and data repeatability.

Engine No. 9, an upgraded Mod I, was the second engine used in the Industrial Test and Evaluation Program and was evaluated by John Deere and Co. Test program objectives were to measure engine performance and evaluate engine noise levels and the use of alternative fuels. Engine No. 10, an upgraded Mod I converted from Engine No. 1, was delivered to NASA for use in technology development efforts.

The total test time accumulated by the Mod I engines exceeded 15,000 hours.

The Mod II

The Mod II represents the culmination of the ASE program efforts through a final achievement of the program objectives. This engine is a substantial departure from the P-40, Mod I, and upgraded Mod I engine configurations and incorporates technologies developed throughout the program. The 1983 Reference engine had the most significant impact on the final Mod II engine design in two key areas. First, the engine was made cost competitive in terms of manufacturability and thus nullified the statement that Stirling engines were too expensive to mass produce. Second, the engine would be packaged in a front-wheel-drive car with a small engine compartment. Hence, the heretofore bulky Stirling engine would now not only be the same size as the standard spark ignition engine but still provide all the advantages inherent in a Stirling engine, i.e., efficiency, multifuel capability, quiet operation, and low emissions.

The Mod II has been designed for installation in a 1985 Chevrolet Celebrity, where its fuel consumption will be evaluated against the four-cylinder spark ignition engine normally supplied in the Celebrity. As reflected in the 1983 Reference engine, the Mod II is a single-crankshaft, four-cycle Stirling V-engine with an annular regenerator and cooler surrounding each double-acting piston. The design is based on a unified, one-piece, cast-iron block incorporating crankcase, gas ducts, control lines, and water jacket.

The Mod II preliminary design phase began after the May 1983 Reference engine review. In parallel with this effort, extensive component and technology development activities were initiated to accommodate the major design change to a V-drive system. Both efforts were mutually supportive as failures and successes in the hardware development were fed back into the design.

In September 1984, an assessment of the readiness of various technologies to be used in the final Mod II detailed design was made, along with an identification of their associated risks. This Mod II Technology Assessment marked the end of the preliminary design phase and the beginning of the detailed design phase that was completed in August 1985. The first Mod II engine was tested in January 1986, and it will be installed in a 1985 Chevrolet Celebrity to formally demonstrate the program objectives by September 1987.

TIMELINE

February 1978

Public Law 95-238, Title III
The Automotive Stirling Engine Development
Program Evolves From This
Legislation

March 1978

Contract DEN3-32 Awarded to MTI

May 1980

Final Mod I Design Review

January 1981

First Mod I Hot Engine Test

April 1981

First Mod I Stirling Engine System Test

August 1981

Mod I Engine Fully Characterized

May 1982

First Mod I Installed in Vehicle

July 1982

First USA-Built Mod I Begins Test

April 1983

First Upgraded Mod I Begins Test

May 1983

Reference Engine Radically Redesigned
Mod II Design Initiated

May 1984

Spirit Vehicle Tested by GM Research Laboratories

April 1985

Mod II Basic Engine Design Review

August 1985

Mod II Engine System Design Review

January 1986

Mod II Begins Testing

September 1987

Program Objectives Demonstrated
Program Ends



P-40 GM Opel

Combined Mileage
6.8 km/L (16 mi/gal)

Acceleration*
38 s



P-40 AMC Spirit

Combined Mileage
7.7 km/L (18 mi/gal)

Acceleration*
34 s

* 0-97 km/h (0-60 mi/hr)



**Stirling-Powered AMC Concord
Demonstration Vehicle**



Upgraded Mod I AMC Spirit

Combined Mileage		Acceleration*
1984	10.7 km/L (25 mi/gal)	25 s
1985	12.2 km/L (28.5 mi/gal)	16 s



Mod I AMC Lerma

Combined Mileage	Acceleration*
10.2 km/L (24 mi/gal)	26 s

BIBLIOGRAPHY

Assessment of the State of Technology of Automotive Stirling Engines. NASA CR-159631, 79ASE77RE2, September 1979.

Mod II Basic Stirling Engine (BSE), Volume I – Design Review Report. 85ASE444DR4, MTI 85TR24, 2 April 1985.

Mod II Stirling Engine System (SES) Design Review Report. 85ASE465DR5, MTI 85TR47, August 1985.

Reference Engine System Design (RESD) Summary Report. NASA CR-174674, 84ASE356ER59, MTI 84TR11, 1 June 1984.

1. Report No. NASA CR-175106		2. Government Accession No.		3. Recipient's Catalog No.	
4. Title and Subtitle AUTOMOTIVE STIRLING ENGINE Mod II Design Report				5. Report Date October 1986	
				6. Performing Organization Code	
7. Author(s) Noel P. Nightingale				8. Performing Organization Report No. MTI86ASE58SR1	
				10. Work Unit No.	
9. Performing Organization Name and Address Mechanical Technology Incorporated 968 Albany-Shaker Road Latham, New York 12110				11. Contract or Grant No. DEN 3-32	
				13. Type of Report and Period Covered Contractor Report	
12. Sponsoring Agency Name and Address U.S. Department of Energy Office of Vehicle and Engine R&D Washington, D.C. 20545				14. Sponsoring Agency Code DOE/NASA/0032--28	
15. Supplementary Notes Final Report. Prepared under Interagency Agreement DE-AI01-85CE50112. Project Manager, W.K. Tabata, Power Technology Division, NASA Lewis Research Center, Cleveland, Ohio 44135.					
16. Abstract The design of an automotive Stirling engine that achieves the superior fuel economy potential of the Stirling cycle is described. As the culmination of a 9-yr development program, this engine, designated the Mod II, also nullifies arguments that Stirling engines are heavy, expensive, unreliable, and demonstrate poor performance. Installed in a General Motors 1985 Chevrolet Celebrity car, this engine has a predicted combined fuel economy on unleaded gasoline of 17.5 km/L (41 mi/gal)-a value 50 percent above the current vehicle fleet average. The Mod II Stirling engine is a four-cylinder V-drive design with a single crankshaft. The engine is also equipped with all the controls and auxiliaries necessary for automotive operation.					
17. Key Words (Suggested by Author(s)) Stirling engine; Fuel economy; Alternative power plant; Automotive; Technology transfer; Mod II; Multifuel				18. Distribution Statement Unclassified - Unlimited Subject Category-85 DOE Category UC-96	
19. Security Classif. (of this report) Unclassified		20. Security Classif. (of this page) Unclassified		21. No of pages 64	22. Price* A04