

---

## **Cogeneration Handbook for the Textile Industry**

---

**February 1984**

**Prepared for:  
U.S. Department of Energy  
Assistant Secretary, Conservation  
and Renewable Energy  
Under Contract DE-AC06-76RLO 1830**

**Prepared by:  
Pacific Northwest Laboratory  
Operated for the U.S. Department of Energy  
by Battelle Memorial Institute**

## DISCLAIMER

"This report was prepared as an account of work sponsored by an agency of the United States Government. Neither the United States Government nor any agency thereof, nor any of their employees, makes any warranty, express or implied, or assumes any legal liability or responsibility for the accuracy, completeness, or usefulness of any information, apparatus, product, or process disclosed, or represents that its use would not infringe privately owned rights. Reference herein to any specific commercial product, process, or service by trade name, trademark, manufacturer, or otherwise, does not necessarily constitute or imply its endorsement, recommendation, or favoring by the United States Government or any agency thereof. The views and opinions of authors expressed herein do not necessarily state or reflect those of the United States Government or any agency thereof."

This report has been reproduced directly from the best available copy.

Available from the National Technical Information Service, U. S. Department of Commerce, Springfield, Virginia 22161.

Price: Printed Copy A08  
Microfiche A01

Codes are used for pricing all publications. The code is determined by the number of pages in the publication. Information pertaining to the pricing codes can be found in the current issues of the following publications, which are generally available in most libraries: *Energy Research Abstracts*, (ERA); *Government Reports Announcements and Index* (GRA and I); *Scientific and Technical Abstract Reports* (STAR); and publication, NTIS-PR-360 available from (NTIS) at the above address.

---

# **Cogeneration Handbook for the Textile Industry**

---

**February 1984**

**Prepared for:  
U.S. Department of Energy  
Assistant Secretary, Conservation  
and Renewable Energy  
Washington, D.C. 20585  
Under Contract DE-AC06-76RLO 1830**

**Prepared by:  
Pacific Northwest Laboratory  
Operated for the U.S. Department of Energy  
by Battelle Memorial Institute**

## CONTENTS

1.0	INTRODUCTION.....	1.1
2.0	DATA BASE DEVELOPMENT.....	2.1
2.1	PRIMARY ENERGY-USE DATA.....	2.1
2.2	STEAM DATA.....	2.1
2.3	EXAMPLE DATA BASE.....	2.3
3.0	MATCHING COGENERATION SYSTEM DESIGNS.....	3.1
3.1	TOPPING CONFIGURATIONS.....	3.1
3.1.1	Steam Turbines.....	3.2
3.1.2	Gas Turbines.....	3.2
3.1.3	Diesel Engines.....	3.2
3.2	PERFORMANCE OF "STANDARD" TOPPING CONFIGURATIONS.....	3.3
3.3	TOPPING CONFIGURATIONS FOR VARIABLE HEAT DEMANDS.....	3.11
3.4	LOAD-DURATION CURVES AND SYSTEM MATCHING.....	3.12
3.5	NOMENCLATURE.....	3.13
4.0	ECONOMIC ANALYSIS.....	4.1
4.1	PRELIMINARY RANK ORDERING.....	4.1
4.2	ESTIMATE INVESTMENT COSTS.....	4.3
4.2.1	Purchased Equipment Costs.....	4.3
4.2.2	Cost Indexes.....	4.4
4.2.3	Cost Factors.....	4.4
4.3	OPERATING AND MAINTENANCE COSTS.....	4.5
4.3.1	Fuel Cost.....	4.5
4.3.2	Electricity Cost or Revenue.....	4.6
4.3.3	Other O&M Costs.....	4.6
4.4	COGENERATION PROJECT CASH FLOWS.....	4.6
4.5	INVESTMENT ANALYSIS TECHNIQUES.....	4.9
4.5.1	Payback Period.....	4.11
4.5.2	Accounting Rate of Return.....	4.11
4.5.3	Life-Cycle Costing Techniques.....	4.13
4.6	SENSITIVITY ANALYSIS.....	4.14
4.7	IMPACT OF TAX PARAMETERS.....	4.16
4.7.1	ETA.....	4.16

4.7.2	COWPTA.....	4.16
4.7.3	ERTA.....	4.17
5.0	FINANCIAL STRATEGIES.....	5.1
5.1	ORDINARY SALE.....	5.1
5.2	SALE WITH BORROWED FINANCING.....	5.1
5.3	LEASE.....	5.2
5.3.1	Ordinary Lease.....	5.2
5.3.2	Third-Party Lease.....	5.2
5.3.3	Leveraged Lease.....	5.2
5.3.4	The Sale-Leaseback Method.....	5.3
5.4	JOINT-VENTURE FINANCING.....	5.4
6.0	ENVIRONMENTAL ISSUES.....	6.1
6.1	FEDERAL REGULATIONS.....	6.1
6.2	TYPES OF POLLUTANTS.....	6.1
6.3	COMBUSTION SYSTEMS AND FUELS.....	6.3
6.3.1	Steam Turbines.....	6.3
6.3.2	Gas Turbines.....	6.3
6.3.3	Diesel Engines.....	6.3
6.4	EMISSION-CONTROL DEVICES.....	6.3
6.4.1	Particulate Emissions Control.....	6.3
6.4.2	Sulfur Dioxide Emissions Control.....	6.4
6.4.3	Nitrogen Oxides Emissions Controls.....	6.5
7.0	LEGAL AND CONTRACTURAL ISSUES.....	7.1
7.1	EXISTING LAWS.....	7.1
7.1.1	PURPA.....	7.1
7.1.2	FUA.....	7.1
7.1.3	NGPA.....	7.1
7.2	REGULATION.....	7.1
7.3	INTERCONNECTION.....	7.2
7.3.1	Regulatory Issues.....	7.2
7.3.2	Technical Issues.....	7.2
7.3.3	Contractural Issues.....	7.3
7.4	OTHER CONTRACTURAL CONSIDERATIONS.....	7.4

7.4.1	The Preconceptual-Design Phase.....	7.4
7.4.2	The Conceptual-Design Phase.....	7.4
7.4.3	The Final Design and Construction Phase.....	7.5
8.0	THREE-PHASE WORK STATEMENTS.....	8.1
8.1	COGENERATION SYSTEM DEVELOPMENT.....	8.1
8.1.1	The Preconceptual-Design Phase.....	8.1
8.1.2	The Conceptual-Design Phase.....	8.4
8.1.3	The Detailed Design and Construction Phase.....	8.5
8.2	TYPICAL SYSTEM DEVELOPMENT AND CONSTRUCTION SCHEDULE.....	8.7
8.3	TYPICAL MAJOR SYSTEM COMPONENTS.....	8.7
8.4	USE OF STANDARD SPECIFICATIONS.....	8.7
8.5	PROJECT CHECKLIST.....	8.8
	ADDITIONAL RESOURCES.....	Bib.1
	GLOSSARY.....	Glos.1
	APPENDIX A: TEXTILE INDUSTRY PROFILE.....	A.1
	APPENDIX B: TYPICAL HEATING VALUES OF COMMONLY-USED FUELS.....	B.1
	APPENDIX C: STEAM PROPERTIES.....	C.1
	APPENDIX D: ASSUMPTIONS USED TO DERIVE PERFORMANCE CURVES.....	D.1
	APPENDIX E: BASIC ECONOMIC CONCEPTS AND TERMINOLOGY.....	E.1
	APPENDIX F: COGENERATION SYSTEM COST ESTIMATES.....	F.1
	APPENDIX G: COGENERATION SYSTEM O&M COST ESTIMATES.....	G.1
	APPENDIX H: U.S. ENVIRONMENTAL PROTECTION AGENCY REGIONAL OFFICES.....	H.1
	APPENDIX I: STATES' COGENERATION RATE-SETTING UNDER PURPA.....	I.1
	APPENDIX J: OPERATING AND EFFICIENCY STANDARDS FOR QUALIFYING FACILITIES.....	J.1
	APPENDIX K: PRECONCEPTUAL-DESIGN PHASE DESCRIPTION OF EVENTS.....	K.1
	APPENDIX L: CONCEPTUAL-DESIGN PHASE DESCRIPTION OF EVENTS.....	L.1
	APPENDIX M: DETAILED-DESIGN-AND-CONSTRUCTION PHASE DESCRIPTION OF EVENTS.....	M.1
	APPENDIX N: SUMMARY OF PRINCIPAL CODES AND STANDARDS.....	N.1
	APPENDIX O: PROJECT CHECK-LIST.....	O.1

## FIGURES

1.1	Steps in Cogeneration Evaluation.....	1.2
2.1	Relationship of Data to be Collected.....	2.1
2.2	Finishing Plant Flow Diagram.....	2.5
3.1	Standard Back-Pressure Steam Turbine.....	3.3
3.2	Standard Gas Turbine.....	3.4
3.3	Standard Combined Cycle.....	3.5
3.4	Standard Diesel.....	3.6
3.5	Steam Turbine Power Output.....	3.7
3.6	Steam Turbine Fuel Use.....	3.7
3.7	Gas Turbine Power Output.....	3.8
3.8	Gas Turbine Fuel Use.....	3.8
3.9	Combined-Cycle Power Output.....	3.9
3.10	Combined-Cycle Fuel Use.....	3.9
3.11	Diesel Power Output and Fuel Use.....	3.10
3.12	Sample Configuration for Changing Heat Demand.....	3.13
3.13	Development of a Load-Duration Curve.....	3.14
4.1	Cogenerated Electricity Cost as a Function of Incremental Heat Rate for Various Fuel Prices.....	4.2
4.2	Preliminary Rank Ordering for the Textile Finishing Mill.....	4.2
5.1	Parties and Types of Financial Aid in an Alternative-Financing Arrangement.....	5.1
5.2	Ordinary Sale.....	5.2
5.3	Sale with Borrowed Financing.....	5.2
5.4	Ordinary Lease.....	5.2
5.5	Third-Party Lease.....	5.2
5.6	Leveraged Lease.....	5.3
5.7	Sale-Leaseback.....	5.3
6.1	Outline of the Preconstruction Review of Major Pollution-Control Regulations.....	6.2
7.1	Determination of Qualifying-Facility Status.....	7.2
8.1	Preconceptual-Design Phase.....	8.2
8.2	Conceptual-Design Phase.....	8.5
8.3	Detailed-Design-and-Construction Phase.....	8.6
8.4	Typical Cogeneration System Development and Construction Schedule.....	8.8

8.5	Equipment Breakdown - Steam Turbine Cogeneration System (coal-fired).....	8.9
8.6	Equipment Breakdown - Steam Turbine Cogeneration System (oil - or gas-fired).....	8.9
8.7	Equipment Breakdown - Gas Turbine Cogeneration System.....	8.10
8.8	Equipment Breakdown - Combined-Cycle Cogeneration System.....	8.11
8.9	Equipment Breakdown - Diesel Cogeneration System.....	8.12



TABLES

2.1	Current Energy Consumption Data.....	2.2
2.2	Process Steam Demand Data.....	2.2
2.3	Process Steam Sendout Calculation.....	2.3
2.4	Fuel Used for Process Steam.....	2.4
2.5	Nonprocess Steam Demand Data.....	2.4
2.6	Textile Finishing Plant.....	2.5
2.7	Current Energy-Consumption Data for a Textile Finishing Mill.....	2.6
2.8	Process Steam Data for a Textile Finishing Mill.....	2.6
2.9	Process Steam Sendout Calculation for Textile Finishing Mill.....	2.6
2.10	Fuel Used for Process Steam in Textile Finishing Mill.....	2.7
2.11	Nonprocess Steam Demand Data for Textile Finishing Mill.....	2.7
3.1	Typical Topping Configurations.....	3.1
3.2	Performance Characteristics of Standard Topping Configurations.....	3.11
3.3	Performance Characteristics of Standard Topping Configurations for the Textile Finishing Plant.....	3.12
4.1	Major Cost Items for a Cogeneration System.....	4.3
4.2	Cogeneration System Investment Estimate.....	4.4
4.3	Average Cost Factors.....	4.5
4.4	Fuel Cost Calculations.....	4.5
4.5	Electricity Cost/Revenue Calculations.....	4.7
4.6	Relative Costs for Fuels.....	4.8
4.7	Escalation of Fuel Costs for Industrial Sector.....	4.8
4.8	Relative Cost Increases for Equipment.....	4.8
4.9	Relative Cost Increases for Labor.....	4.9
4.10	Cogeneration Project Cash Flows.....	4.9
4.11	Cogeneration System Investment Estimate for Textile Finishing Mill Example.....	4.10
4.12	Fuel Cost Calculations for Textile Finishing Mill Example.....	4.11
4.13	Electricity Cost/Revenue Calculations for Textile Finishing Mill Example.....	4.12
4.14	Cogeneration Project Cash Flows for Textile Finishing Mill Example.....	4.13
4.15	Investment Analysis.....	4.15
6.1	Emission Levels Considered Significant Under PSD Regulations.....	6.3

## 1.0 INTRODUCTION

Rising electricity prices and recent conservation legislation providing economic benefits to cogenerators have combined to revive industrial cogeneration in the United States. Cogeneration is the simultaneous production of electricity (or mechanical energy) and useful heat (thermal energy) from the same fuel source. There are two basic cogeneration systems: topping and bottoming cycles. In a topping cycle, electricity is produced first and the rejected heat from the prime mover is used for process heating. In a bottoming cycle, electricity is produced from the heat remaining in the stream after the process heat requirements have been satisfied.

Cogeneration can be accomplished at a utility's central-station power plant or at an industrial plant. This handbook deals only with industrial cogeneration, that is, simultaneous production of both heat and electricity at the industrial plant site. The cogenerator has the option of either selling all cogenerated power to the utility while simultaneously purchasing power to satisfy his plant demand, or directly supplying the plant demand with cogenerated power, thus displacing utility-supplied power. This decision depends on economic considerations that are very plant specific. In the latter case, purchased electricity is needed to provide back-up or peak power.

The U.S. Department of Energy (DOE) contracted with Pacific Northwest Laboratory (PNL) to provide the textile plant manager or company energy coordinator with a framework for making a preliminary assessment of the feasibility and viability of cogeneration at a particular plant. The handbook is intended to provide an understanding of the potential of several standardized cogeneration systems, as well as their limitations. However, because the decision to cogenerate is very site specific, the handbook cannot provide all of the answers. It does attempt, however, to bring to light the major issues that should be addressed in the decision-making process.

The decision of whether to cogenerate involves several considerations, including technical, economic, environmental, legal, and regulatory issues. Each of these issues is addressed separately in this handbook. In addition, a chapter is included on preparing a three-phase work statement, which is needed to guide the design of a cogeneration system. Experience has shown that a well-defined work statement can be the key to a rapid and cost-effective design effort.

This is important whether or not a contract is let to an A&E firm.

Figure 1.1 shows the six basic steps that will lead to a preliminary determination of the feasibility of cogeneration. These six steps are discussed in Chapters 3.0 through 8.0. The information is presented in a workbook manner. That is, information is presented, an example is given, and room is provided to record plant-specific data. The six basic steps are summarized below:

- Develop Data Base. Describes what energy data should be collected, where to obtain the data, and how to organize the data in a useful format for the analysis.
- Select and Size the Cogeneration System. Describes the most appropriate applications of the various cogeneration configurations. Describes how to size the system based on the energy data compiled in the first step.
- Determine System Costs and Perform Economic Analysis. Describes how to estimate the capital and operating cost of the cogeneration system. Provides a methodology for determining economic feasibility and for testing the sensitivity of the feasibility to escalating fuel, electricity, or O&M costs.
- Consider Environmental Issues. Summarizes pertinent air-quality, water-quality, and solid-waste standards. Discusses environmental control equipment that may be required with particular cogeneration configurations and fuels.
- Consider Legal and Contractual Issues. Describes existing laws and regulations that may impact cogeneration. Summarizes contractual considerations for utility interaction.
- Prepare Three-Phase Work Statement. Provides a checklist of what to include when preparing a work statement for development of preconceptual, conceptual, and detailed design packages, including bidding and construction procedures.

In addition, an annotated bibliography and a glossary of terminology are provided. Appendix A provides an energy-use profile of the textile industry. Appendices B through O provide specific information that will be called out in subsequent chapters.

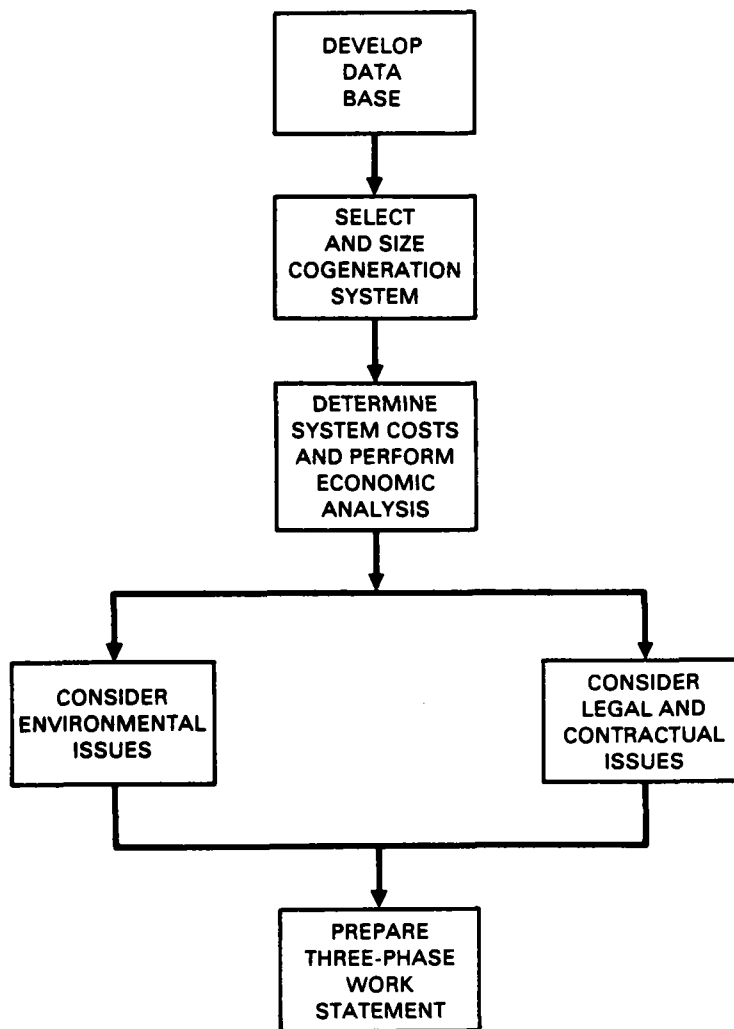

**FIGURE 1.1.** Steps in Cogeneration Evaluation

This handbook is one of a series of five handbooks, each specific to one of the following five industrial sectors:

- Food and Kindred Products (SIC 20)
- Textile Mill Products (SIC 22)
- Paper and Allied Products (SIC 26)
- Chemicals and Allied Products (SIC 28)
- Petroleum Refining (SIC 2911).

## 2.0 DATA BASE DEVELOPMENT

The first step in determining whether cogeneration is feasible for an industrial plant is to assemble a plant energy-use data base. This data base will define the plant energy profile without cogeneration, which will be referred to as the "base case." This chapter provides the tools needed to develop the data base for the base case. That data base will be used in later chapters to select the proper cogeneration configuration and to analyze its performance. Tables for compiling the necessary data are provided for convenience, and examples of completed tables are included for clarification at the end of the chapter.

Three types of data need to be collected: (1) primary energy-use data, (2) steam data, and (3) direct-heat data. Figure 2.1 shows the relationship among these data. Not all of the data compiled in this chapter will be used in the preliminary assessment. However, these data will be required for any more-detailed analyses that later may be undertaken. Each type of data is discussed in more detail in the following sections.

### 2.1 PRIMARY ENERGY-USE DATA

Table 2.1 provides space for recording current power and fuel-consumption data for the plant as a whole. The quantity of both purchased and internally generated fuels and electricity should be recorded. If waste products are used as fuels, the type of waste material and the amount should be recorded.

Aggregate plant energy-consumption data are generally available from power and fuel bills for purchased fuels and electricity. In some cases, plants have internal metering devices or record-keeping systems to track the power and fuel consumption by individual unit operations. Plant operation records may contain information on waste fuels; if not, judgment will have to be used to obtain an estimate.

If the plant energy load is fairly constant over the year, monthly usage does not have to be recorded. If the plant experiences wide variations in energy use, you may want to shorten the time period for data recording to one month or less.

To facilitate later calculations, fuel-use quantities are recorded in million British thermal units ( $10^6$  Btu). If plant energy-use records are not in these units, fuel heating values can be used to convert fuel quantities to  $10^6$  Btu. Heating values can be obtained from plant records or from fuel suppliers. Appendix B lists some typical heating values of commonly used fuels.

### 2.2 STEAM DATA

Table 2.2 provides a format for compiling process-steam demand data. Generally, the temperature and pressure of the steam leaving the boiler(s) are available from boiler-house records. In filling out the table, the properties of the steam allocated to

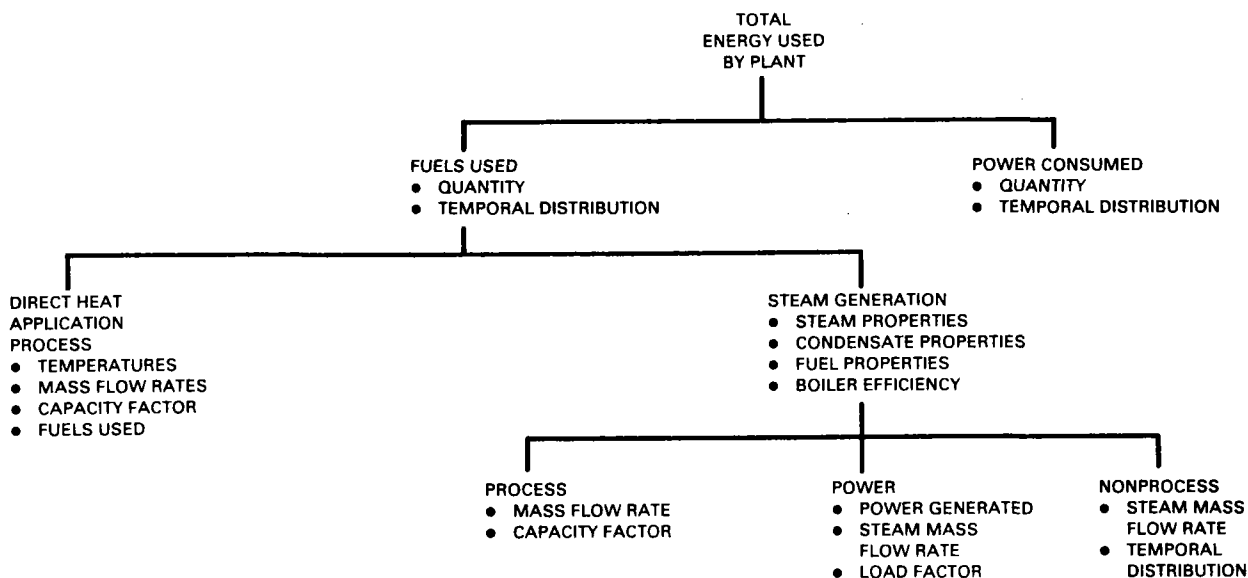

FIGURE 2.1. Relationship of Data to be Collected

TABLE 2.1. Current Energy-Consumption Data

MONTH	POWER (kWh)	FUELS (SPECIFY TYPE)			
		(10 <sup>6</sup> BTU)	(10 <sup>6</sup> BTU)	(10 <sup>6</sup> BTU)	(10 <sup>6</sup> BTU)
JAN					
FEB					
MAR					
APR					
MAY					
JUN					
JUL					
AUG					
SEP					
OCT					
NOV					
DEC					
ANNUAL TOTAL					

TABLE 2.2. Process-Steam Demand Data

	STEAM PROPERTIES		BASE LOAD		PEAK LOAD		CONDENSATE	
	PRESSURE (psig)	TEMPERATURE (°F)	MASS FLOW RATE (lb/hr)	LOAD FACTOR (hr/year)	MASS FLOW RATE (lb/hr)	LOAD FACTOR (hr/year)	TEMPERATURE (°F)	% RETURNED
STEAM 1								
STEAM 2								
STEAM 3								

process uses is recorded first. Steam flows currently used for power generation are not included.

Next, the baseload mass flow rate of the steam from each boiler is recorded. This represents the amount of steam that is continuously supplied. The number of hours per year that this amount of steam is supplied is recorded as the load factor. The peak mass flow rate of steam and the peak load factor (hours/year) are recorded next.

For each steam source two condensate properties are to be recorded: (1) the condensate temperature, and (2) the percentage of the condensate that is returned to the boiler.

If these data are not available, standard values of 170°F and 100% return can be assumed, since this assumption affects total energy consumption by only 10% at zero condensate return.

Table 2.3 provides a format for calculating the heat content of the process-steam send-out, H. If the standard assumptions were used for the condensate conditions recorded in Table 2.2, an approximate heat content can be calculated simply by multiplying the mass flow rate of the steam by 1050. Using the data collected in Tables 2.2 and 2.3, H is calculated as the product of the mass flow rate and the difference between the

TABLE 2.3. Process-Steam Sendout Calculation

	x	h <sub>c</sub>	h <sub>w</sub>	h <sub>i</sub>	h <sub>o</sub>	m	H
	CONDENSATE RETURNED (%)	CONDENSATE ENTHALPY (BTU/lb)	MAKE-UP WATER ENTHALPY (BTU/lb)	FEED WATER ENTHALPY (BTU/lb)	STEAM ENTHALPY (BTU/lb)	MASS FLOW RATE (lb/hr)	HEAT CONTENT OF SENDOUT (BTU/hr)
STEAM 1							
STEAM 2							
STEAM 3							
						TOTAL	

steam enthalpy (heat content) at the boiler outlet and the feedwater enthalpy at the boiler inlet. That is,

$$H = m(h_o - h_i)$$

where

- m = the mass flow rate (lb/hr)
- h<sub>o</sub> = the steam enthalpy at the boiler outlet (Btu/lb)
- h<sub>i</sub> = the feedwater enthalpy at the boiler inlet (Btu/lb).

The enthalpy of the steam can be obtained from the steam tables in Appendix C, using the temperature and pressure recorded in Table 2.2. The enthalpy of the feedwater is calculated as follows:

$$h_i = xh_c + (1 - x)h_w$$

where

- x = the percentage of condensate returned
- h<sub>c</sub> = the enthalpy of the condensate (Btu/lb)
- h<sub>w</sub> = the enthalpy of the make-up water (Btu/lb).

The process-steam sendout values are then totalled to obtain a total for the plant.

Once the process-steam sendout is determined, the plant power-to-heat ratio can be calculated as follows:

$$\text{plant power-to-heat ratio} = \frac{\text{annual power use (kWh)}}{\text{process steam sendout} \times \text{load factor}}$$

(kWh/10<sup>6</sup> Btu)      (10<sup>6</sup> Btu/hr)      (hr/yr)

This value will be compared to the power-to-heat ratios calculated for various cogeneration configurations in Chapter 3.0.

Table 2.4 provides a format for calculating the fuel used for raising steam for process uses. For each steam source, the type of fuel burned, the heat content of the process-steam sendout (from Table 2.3), and the boiler efficiency are recorded. Then the fuel used to produce process steam is calculated by dividing the heat content by the boiler efficiency.

Table 2.5 provides a format for recording nonprocess-steam demand data. Because nonprocess-steam demand generally varies with time and with the season, the table is set up to record data on a monthly basis. If nonprocess-steam uses are large compared to process uses, diurnal variations should be considered. For each steam source, the total monthly consumption, the average mass flow rate of steam, and the peak flow rate for nonprocess uses are recorded. The monthly consumption figures are totalled to obtain annual nonprocess-steam consumption.

### 2.3 EXAMPLE DATA BASE

In this section an example is used to illustrate the development of a data base for a finishing plant. The example is not intended to be representative of the entire textile industry, but simply to illustrate the methodologies presented in this and in subsequent chapters. It is recognized that heat and power demands vary widely from mill to mill. Mills vary in size, degree of integration, products, equipment, age, state of conservation efforts, etc. Therefore, actual results will differ from the example.

Figure 2.2 provides a generalized process flow diagram for a large-capacity finishing plant.<sup>(1)</sup> The plant selected for discussion is estimated to have a weekly production capability of 2.5 million yards of finished

TABLE 2.4. Fuel Used for Process Steam

	H	$\eta_b$	$F_o^{(a)}$
	FUEL TYPE	PROCESS STEAM SENDOUT (BTU/hr)	BOILER EFFICIENCY (%)
STEAM 1			
STEAM 2			
STEAM 3			
		TOTAL	

<sup>(a)</sup>  $H/\eta_b = F_o$

TABLE 2.5. Nonprocess-Steam Demand Data

MONTH	STEAM 1			STEAM 2			STEAM 3		
	CONSUMPTION (lb)	AVERAGE FLOW RATE (lb/hr)	PEAK FLOW RATE (lb/hr)	CONSUMPTION (lb)	AVERAGE FLOW RATE (lb/hr)	PEAK FLOW RATE (lb/hr)	CONSUMPTION (lb)	AVERAGE FLOW RATE (lb/hr)	PEAK FLOW RATE (lb/hr)
JAN									
FEB									
MAR									
APR									
MAY									
JUN									
JUL									
AUG									
SEP									
OCT									
NOV									
DEC									
ANNUAL TOTAL									

goods. The operating profile is characterized as 24 hours/day, 5 days per week, resulting in an average of 6240 hours/year. The primary energy to the boiler is assumed to be coal. Natural gas is used for direct-fired operations (e.g., singeing and drying), and purchased electricity is used to operate process equipment and for lighting

and air conditioning. Table 2.6 summarizes plant capacity and operating characteristics.

Tables 2.7 to 2.11 show the development of a data base for the plant. In this example, no monthly data are available. However, in a real plant the monthly data on energy consumption and nonprocess-steam demands (if applicable) would be obtainable.

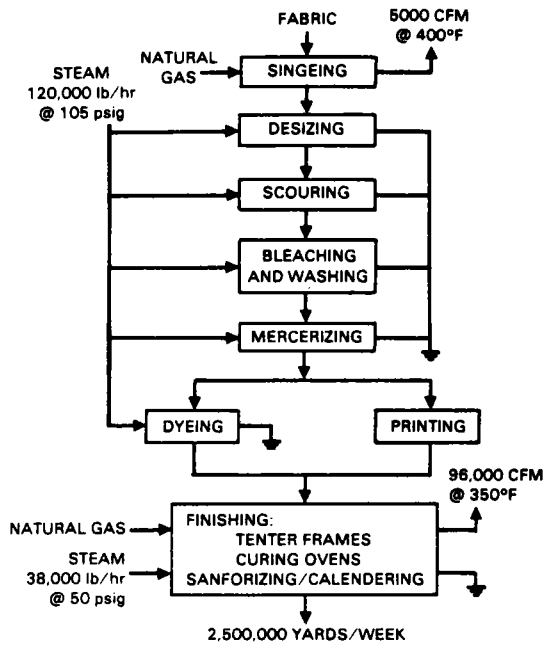

FIGURE 2.2. Finishing Plant Flow Diagram

TABLE 2.6. Textile Finishing Plant

MATERIAL AND ENERGY DATA

PLANT CAPACITY: 2,500,000 YDS/WK

OPERATING HOURS: 6240 HR/YR

ENERGY FLOW:

Electricity

Purchased —————> Process Equipment  
 —————> Lighting, etc.  
 —————> Air Conditioning

Heat (Indirect)

Low-Pressure Steam —————> Process Heat  
 —————> Hot Water Generation

Heat (Direct)

Natural Gas, Coal, Fuel Oil —————> Process Heat  
 —————> Steam Production

ELECTRICAL REQUIREMENTS:

6.2 MW Normal

6.8 MW Peak

STEAM REQUIREMENTS:

38,000 LB/HR 50 PSIG

120,000 LB/HR 105 PSIG

DIRECT HEAT:

Natural Gas (Singeing, Drying, Curing) - 38,500 ft<sup>3</sup>/hr

Coal (Steam Production) - 230 tons/day



TABLE 2.7. Current Energy-Consumption Data for a Textile Finishing Mill

MONTH	FUELS (SPECIFY TYPE)				
	POWER (kWh)	COAL (10 <sup>6</sup> BTU)	NAT. GAS (10 <sup>6</sup> BTU)	(10 <sup>6</sup> BTU)	(10 <sup>6</sup> BTU)
JAN					
FEB					
MAR					
APR					
MAY					
JUN					
JUL					
AUG					
SEP					
OCT					
NOV					
DEC					
ANNUAL TOTAL	38.7x10 <sup>6</sup>	1.57x10 <sup>6</sup>	0.24x10 <sup>6</sup>		

TABLE 2.8. Process-Steam Data for Textile Finishing Mill

	STEAM PROPERTIES		BASE LOAD		PEAK LOAD		CONDENSATE	
	PRESSURE (psig)	TEMPERATURE (°F)	MASS FLOW RATE (lb/hr)	LOAD FACTOR (hr/year)	MASS FLOW RATE (lb/hr)	LOAD FACTOR (hr/year)	TEMPERATURE (°F)	% RETURNED
STEAM 1	50	298	38,000	6240			180	30
STEAM 2	105	341	120,000	6240			212	30
STEAM 3								

TABLE 2.9. Process-Steam Sendout Calculation for Textile Finishing Mill

	x	h <sub>c</sub>	h <sub>w</sub>	h <sub>i</sub>	h <sub>o</sub>	m	H
	CONDENSATE RETURNED (%)	CONDENSATE ENTHALPY (BTU/lb)	MAKE-UP WATER ENTHALPY (BTU/lb)	FEED WATER ENTHALPY (BTU/lb)	STEAM ENTHALPY (BTU/lb)	MASS FLOW RATE (lb/hr)	HEAT CONTENT OF SENDOUT (BTU/hr)
STEAM 1	30	148	30	65.4	1179	38,000	42.3x10 <sup>6</sup>
STEAM 2	30	180	30	75.0	1190	120,000	133.8x10 <sup>6</sup>
STEAM 3							
						TOTAL	176.1x10 <sup>6</sup>

TABLE 2.10. Fuel Used for Process Steam in Textile Finishing Plant

		H	$\eta_b$	$F_o^{(a)}$
	FUEL TYPE	PROCESS STEAM SENDOUT (BTU/hr)	BOILER EFFICIENCY (%)	FUEL USE (BTU/hr)
STEAM 1	COAL	42.3x10 <sup>6</sup>	70	60.4x10 <sup>6</sup>
STEAM 2	COAL	133x10 <sup>6</sup>	70	191.1x10 <sup>6</sup>
STEAM 3				
TOTAL				251x10 <sup>6</sup>

<sup>(a)</sup>  $H/\eta_b = F_o$

TABLE 2.11. Nonprocess-Steam Demand Data for Textile Finishing Mill

MONTH	STEAM 1			STEAM 2			STEAM 3		
	CONSUMPTION (lb)	AVERAGE FLOW RATE (lb/hr)	PEAK FLOW RATE (lb/hr)	CONSUMPTION (lb)	AVERAGE FLOW RATE (lb/hr)	PEAK FLOW RATE (lb/hr)	CONSUMPTION (lb)	AVERAGE FLOW RATE (lb/hr)	PEAK FLOW RATE (lb/hr)
JAN									
FEB									
MAR									
APR									
MAY									
JUN									
JUL									
AUG									
SEP									
OCT									
NOV									
DEC									
ANNUAL TOTAL	0			0			0		

REFERENCES

- Palmer, W. B., et al. 1980. Cogen-eration Technology Alternatives Study (CTAS). Volume III: Industrial Processes. DOE/NASA-0031-80/3, U.S. Department of Energy, Washington, D.C.

### 3.0 MATCHING COGENERATION SYSTEM DESIGNS

This chapter discusses the selection and sizing of cogeneration configurations that will meet the specified process steam demand developed in the plant energy-use data base (Chapter 2.0). Four "standard" topping configurations are considered: (1) steam turbine, (2) gas turbine, (3) combined cycle, and (4) diesel. The performance of the topping configurations in terms of net power generated, heat content of steam sendout, and fuel consumption will provide the quantitative basis for the economic analysis to follow in Chapter 4.0. Time-variant heat and power demands and several options to vary the power-to-heat ratio to overcome mismatches between power and heat demands are also discussed.

Steam is the predominant heat-transfer medium in industrial processes, and providing steam is a key concern of plant operators. Therefore, industrial power generation will generally "track" the steam demand, not the power demand. This is in strong contrast to a utility's central-station power plant, where meeting the power demand is the primary concern. The steam demand imposed by the manufacturing process will, in most cases, be comparatively constant over extended periods. Nonprocess-steam demand (e.g., for space heating and cooling) will, in general, vary with time and season.

#### 3.1 TOPPING CONFIGURATIONS

Current technology offers several prime-mover configurations for the topping of process steam. Topping cycles may use steam turbines, gas turbines, or diesel engines for producing electricity. The choice of prime mover depends upon the relative amounts of process heat and electricity desired and the process-heating application. Typical topping configurations are summarized in Table 3.1, and characteristics of each of the prime movers are discussed in more detail in the following sections.

The power-to-heat ratio,<sup>(a)</sup> the fuel-use efficiency,<sup>(b)</sup> and the incremental heat rate<sup>(c)</sup> are key parameters used to evaluate

- (a) The power-to-heat ratio refers to the relative amounts of electricity and heat produced by the cogeneration system.
- (b) The fuel-use efficiency is the ratio of electric output plus heat recovered in Btu to the fuel input in Btu. This measure gives credit to the useful thermal output of the system.
- (c) The incremental heat rate is the ratio of fuel consumed minus heat supplied to the net power output of the prime mover. This represents the additional amount of fuel needed to generate each increment of power.

TABLE 3.1. Typical Topping Configurations

<u>Prime Mover</u>	<u>Configuration</u>	<u>Fuel</u>
Steam turbine	Back-pressure turbine	Coal
	Extraction/condensing turbine	Residual Fuel Oil Distillate Fuel Oil Natural Gas Wood Waste Fuels
Gas turbine	Waste-heat boiler in exhaust stream	Natural Gas Distillate Fuel Oil Residual Fuel Oil Synthesis Gas (Coal or Wood)
Combined cycle	Gas turbine with high-pressure waste-heat boiler, followed by a steam turbine	Natural Gas Distillate Fuel Oil Residual Fuel Oil Synthesis Gas
Diesel	Waste-heat boiler in exhaust stream Sometimes hot-water generation through jacket-cooling	Residual Fuel Oil Distillate Fuel Oil Gaseous Fuels

cogeneration configurations. As summarized below, these parameters vary depending on the prime-mover:

- For a given capacity, the power-to-heat ratio is lowest for the steam turbine and highest for the diesel.
- For a given capacity, the fuel-use efficiency rate is highest for the steam turbine and lowest for the diesel.
- The incremental heat rate, ihr, at a given capacity, is lowest for the steam turbine and highest for the diesel.

### 3.1.1 Steam Turbines

Steam turbines include back-pressure, extraction/noncondensing, and extraction/condensing configurations. Back-pressure turbines are steam turbines that are designed to exhaust steam at temperatures and pressures suitable for process-heat applications. Extraction turbines are steam turbines that are designed with an intermediate port for steam extraction at a pressure between the inlet and outlet pressures. Extraction/noncondensing turbines provide two sources of process steam: high-pressure steam from an intermediate extraction port and lower-pressure exhaust steam. In an extraction/condensing turbine, the only source of process steam is the intermediate extraction port; all of the exhaust steam is condensed.

Steam turbines are available in unit sizes (single casing) from 500 kW to 150 MW. (Much larger units are used in central-station power plants for straight condensing service.) Back-pressure units are available in unit sizes up to 50 MW, with larger units being rated for straight condensing service.<sup>(1)</sup>

Extraction/condensing turbines offer operating flexibility when steam and electric loads vary significantly.<sup>(1)</sup> Power-to-heat ratios for steam turbines range from about 30 to 75 kWh/10<sup>6</sup> Btu. Full-load electric efficiencies range from about 14 to 28%, with 50% part-load efficiencies varying from 12 to 25%.<sup>(2)</sup> Steam can be obtained from the turbine at one or more extraction points to serve a variety of useful functions, such as process and space heating at various temperature conditions. More steam can be condensed to give additional power when process steam demands are low, or the boiler output can be reduced to give constant or reduced power at different process-steam demands.

### 3.1.2 Gas Turbines

Gas turbines are used in direct, indirect, and indirect/combined-cycle systems. In direct gas-turbine topping cycles, the hot exhaust gases from the turbine are used for direct process heating and drying, or as highly preheated combustion air in boilers. In an indirect system, the energy in the hot turbine exhaust gases is recovered in a waste-heat boiler to produce process steam. Combined gas/steam turbine cogeneration provides greater flexibility than either gas or steam turbines alone. In this configuration, heat is recovered from the hot exhaust to generate steam in a waste-heat boiler. The steam is subsequently expanded in a back-pressure steam turbine to produce low-pressure process steam and electricity. Additional fuel may be burned in the waste-heat boiler to produce higher pressure steam. This is referred to as supplemental firing.

Gas turbines are commercially available in unit sizes ranging from 6 kW to 100 MW. Power-to-heat ratios are much higher for gas turbines than for steam turbines, with typical values for indirect systems ranging from 140 to 225 kWh/10<sup>6</sup> Btu. Full-load electric efficiencies range from 24 to 35%, and 50% part-load efficiencies range from 19 to 29%. Typical power-to-heat ratios for combined-cycle systems range from 175 to 320 kWh/10<sup>6</sup> Btu. Full-load electric efficiencies range from 34 to 40%, and 50% part-load efficiencies range between 25 and 30%.<sup>(2)</sup>

Gas turbines can operate on natural gas, distillate fuel oil, crude oil, residual fuel oil or synthesis gas derived from coal or wood. Dual-fuel units are also available. Maximum reliability is obtained with natural gas; forced outages statistically occur less than 1% of the operating hours (99% reliability), and scheduled outages occur 2 to 3% of the operating hours (96 to 97% overall availability). Units operating on oil, especially residual fuel oil, require more frequent maintenance.<sup>(1)</sup>

### 3.1.3 Diesel Engines

Cogeneration systems using diesel engines include direct, indirect, and indirect/combined cycles. In direct applications, the hot exhaust gas from the engine is used for process heating or drying. Indirect applications use hot water obtained from the engine's cooling system in a heat exchanger, and/or process steam produced from the hot

exhaust gases in a waste-heat boiler. Indirect/combined-cycle applications use steam turbines to generate additional electricity from the steam generated in the waste-heat boiler. Low-pressure steam from the turbine is used for process heat.

The temperature of diesel exhaust gases is generally lower than that of gas turbines, typically 500 to 950°F. Steam pressure obtained in waste-heat boilers is generally lower than about 400 psig. In slow-speed diesels, where exhaust-gas temperatures are lower than 650°F, steam pressures are usually less than about 200 psig. Higher pressures can be obtained, but at a significant penalty in mass flow and boiler efficiency. Thus, supplemental firing is generally used to achieve high steam pressures and mass flows. In addition to releasing heat through their exhaust gases, diesels reject a substantial fraction of low-temperature heat in their cooling systems. This hot water is useful for space or process-heating applications.<sup>(1)</sup>

The power-to-heat ratios of the diesel range from 350 to 700 kWh/10<sup>6</sup> Btu, which is normally in excess of the power-to-heat ratios demanded by industrial production processes. Moreover, the largest commercially available diesels are in the 25 to 30 MW range; using only the reject heat of the exhaust gas would barely generate 40,000 to 50,000 lb/hr of steam. Diesels can operate as efficient and economic cogenerators in special situations; in most cases the power-to-heat ratio will be varied by using the reject heat in the cooling cycle or by supplemental firing.

### 3.2 PERFORMANCE OF "STANDARD" TOPPING CONFIGURATIONS

The purpose of this section is to present a method of determining the performance characteristics of four "standard" topping configurations for a given heat demand:

- a back-pressure steam turbine operating at modest throttle conditions (Figure 3.1)

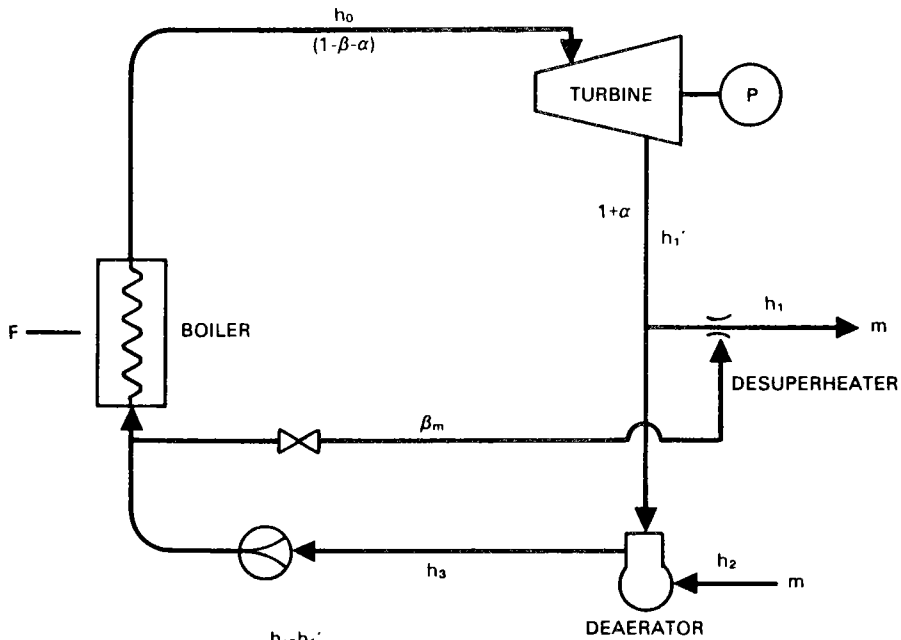

$$\eta_t = 0.02 + 0.0785 \ln P = \frac{h_o - h_1'}{h_o - h_1^*}$$

$$P = m(1 - \beta + \alpha)(h_o - h_1') / 3413$$

$$\alpha = \frac{h_3 - h_2}{h_1' - h_3} \quad \beta = \frac{h_1' - h_1}{h_1' - h_3} \quad (1 - \beta + \alpha) = \frac{h_1 - h_2}{h_1' - h_3}$$

$$F = m(1 - \beta + \alpha)(h_o - h_3) / \eta_b$$

$$P_e = \eta_c P$$

FIGURE 3.1. Standard Back-Pressure Steam Turbine

- a gas turbine operating at modest inlet temperature (Figure 3.2)
- a combined-cycle configuration, consisting of the same gas turbine, trailed by a steam turbine (Figure 3.3)
- diesels of varying speeds and heat rates, equipped with waste-heat boilers generating saturated steam (Figure 3.4). No use is made of the heat content of the jacket cooling water.

The performance characteristics of these systems can be determined by one of two

approaches. One approach is to solve the heat-and-mass-balance equations for each system. These equations are given with Figures 3.1 through 3.4. The second approach uses performance curves derived from these equations and several simplifying assumptions to obtain an approximate solution. This latter methodology is described below and an example is provided to illustrate its use.

Figures 3.5 to 3.11 show the net power output,  $P_e$ , and fuel use,  $F$ , as a function of steam sendout mass flow rate,  $m$ , and steam

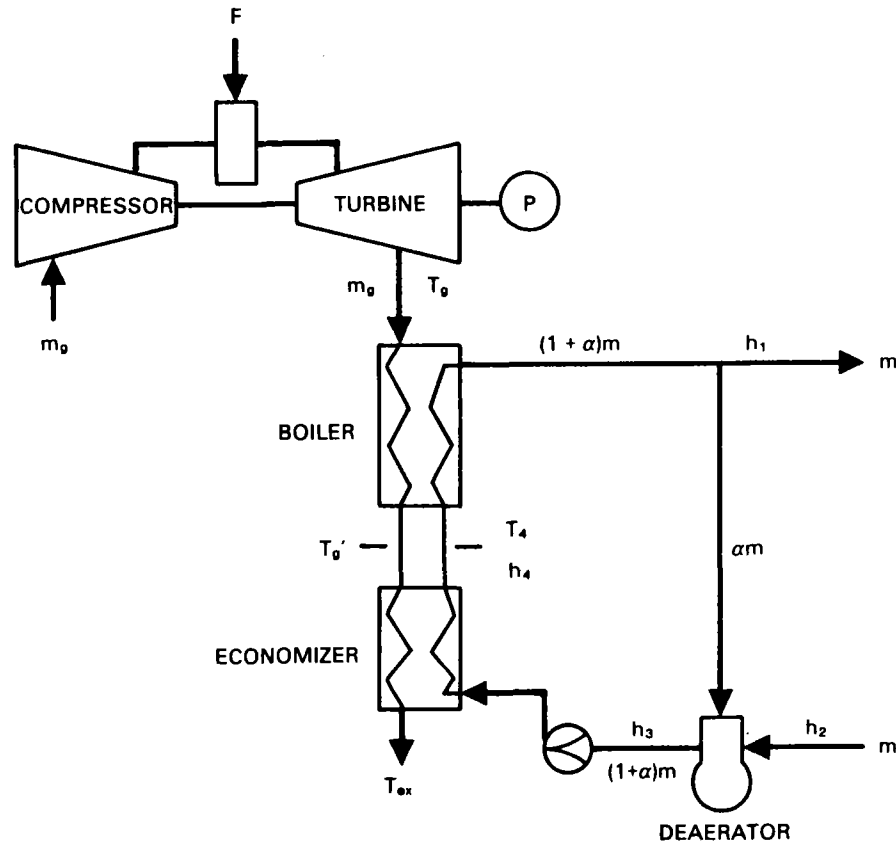

$$m_g = \frac{m}{C_p \eta_g} (1 + \alpha) \frac{h_1 - h_4}{T_g - T_g'}$$

$$(1 + \alpha) = \frac{h_1 - h_2}{h_1 - h_3}$$

$$m_g / P = 55.437 - 2.1321 \ln P$$

$$F = 0.030622 P^{0.9081}$$

$$P_e = \eta_c P$$

FIGURE 3.2. Standard Gas Turbine

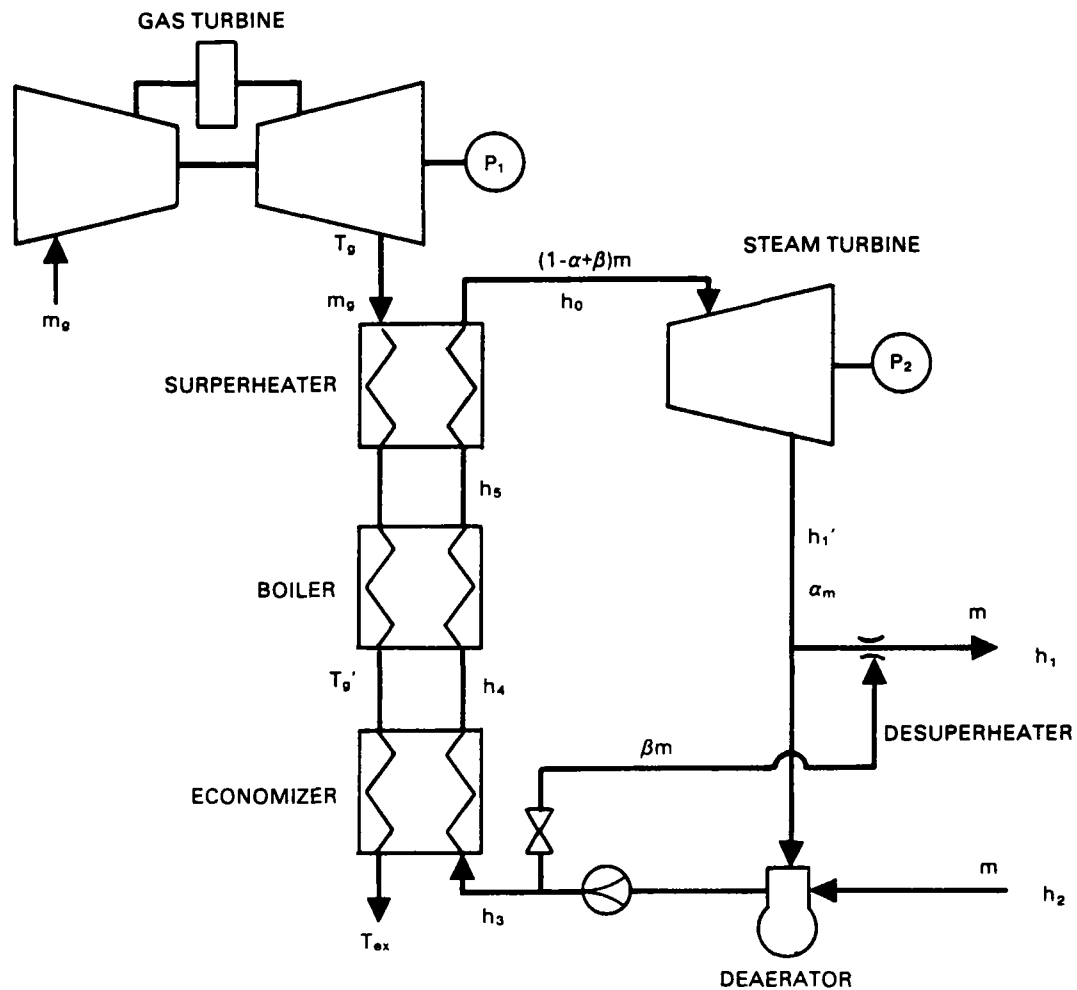

STEAM TURBINE:  $\eta = 0.02 + 0.0785 \ln P_2$

$$P_2 = m(1-\beta+\alpha)(h_0-h_1')/3413$$

GAS TURBINE:  $m_g = \frac{m}{C_p \eta_g} (1-\beta+\alpha) \frac{h_0-h_4}{T_g-T_g'}$

$$m_g/P_1 = 55.437 - 2.1321 \ln P_1$$

$$F = 0.030662 P_1^{0.90581}$$

$$\alpha = \frac{h_3-h_2}{h_1'-h_3}$$

$$\beta = \frac{h_1'-h_1}{h_1'-h_3}$$

$$1-\beta+\alpha = \frac{h_1-h_2}{h_1'-h_3}$$

$$P_e = \eta_c(P_1 + P_2)$$

FIGURE 3.3. Standard Combined Cycle

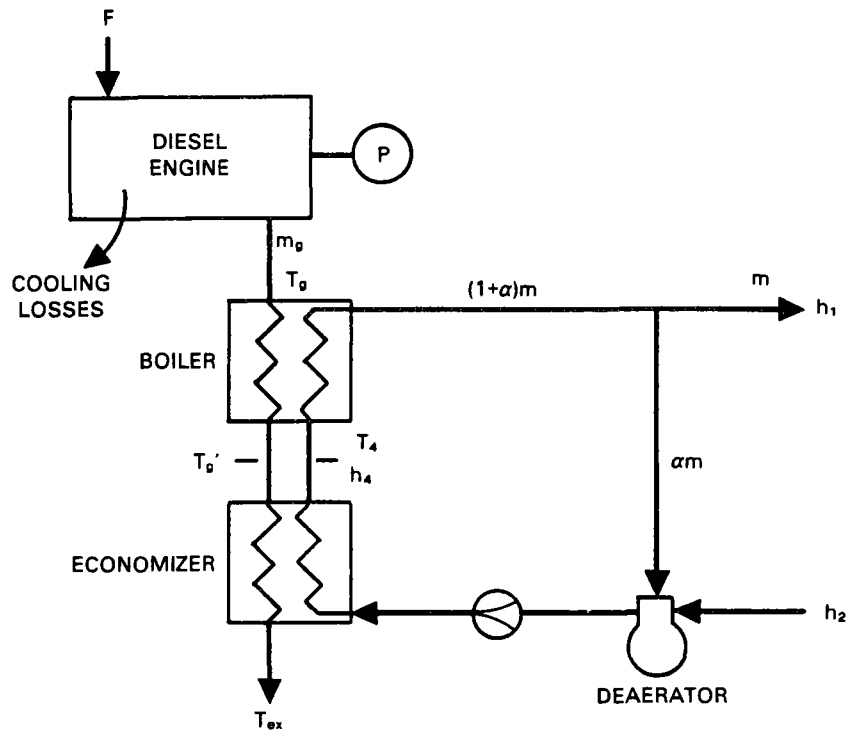

RATED CAPACITY (MW)	1.0 TO 2.5	2.0 TO 6.0	5.0 TO 12.0
HEAT RATE, HR (BTU/kWh)	10200	9600	9000
TYPICAL SPEED (rpm)	1200	450	120

$$m = \left( \frac{a/f}{HV} \right) (HR)(Cp) \left[ \frac{T_g - T_g'}{h_1 - h_4} \right] \frac{1}{1+\alpha} P$$

$$\frac{1}{1+\alpha} = \frac{h_1 - h_3}{h_1 - h_2}$$

$$F = (HR) P$$

$$Pe = \eta_c P$$

FIGURE 3.4. Standard Diesel



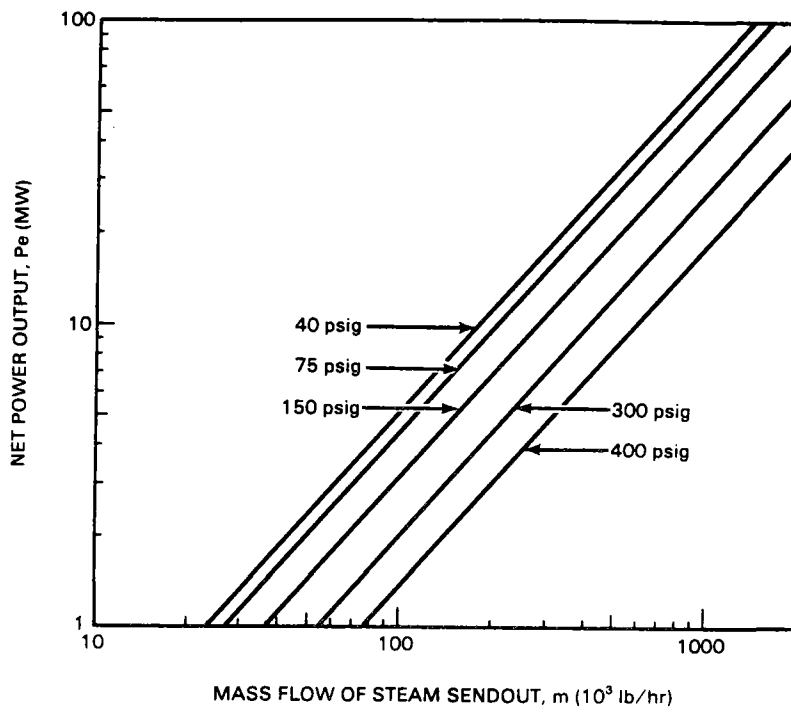

FIGURE 3.5. Steam Turbine Power Output

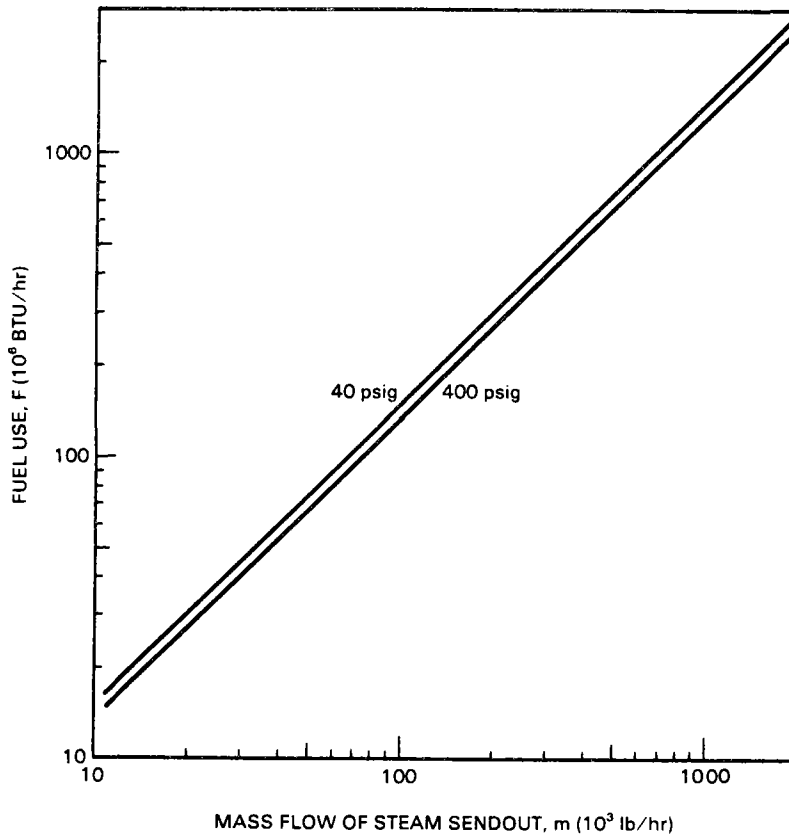

FIGURE 3.6. Steam Turbine Fuel Use

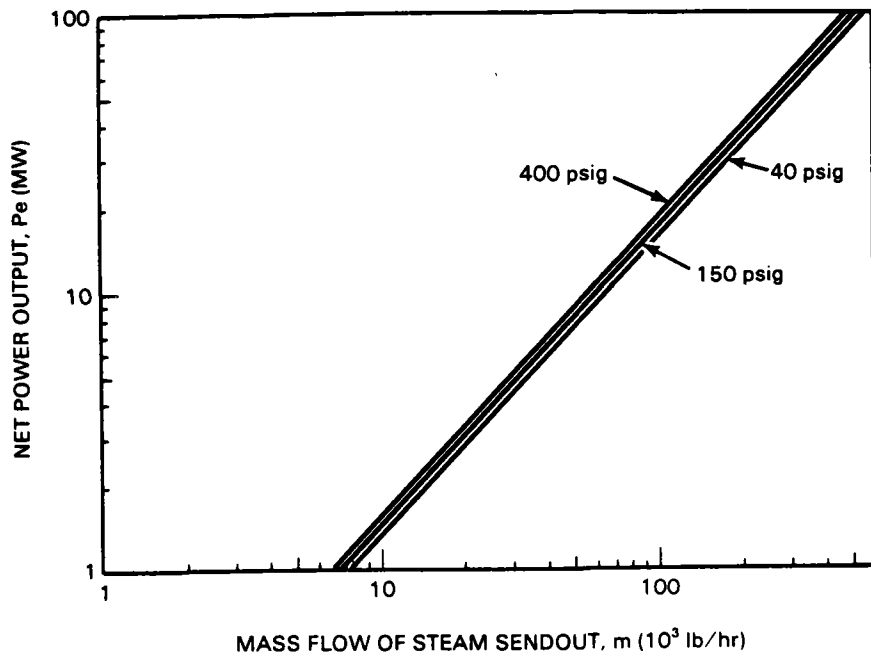

FIGURE 3.7. Gas Turbine Power Output

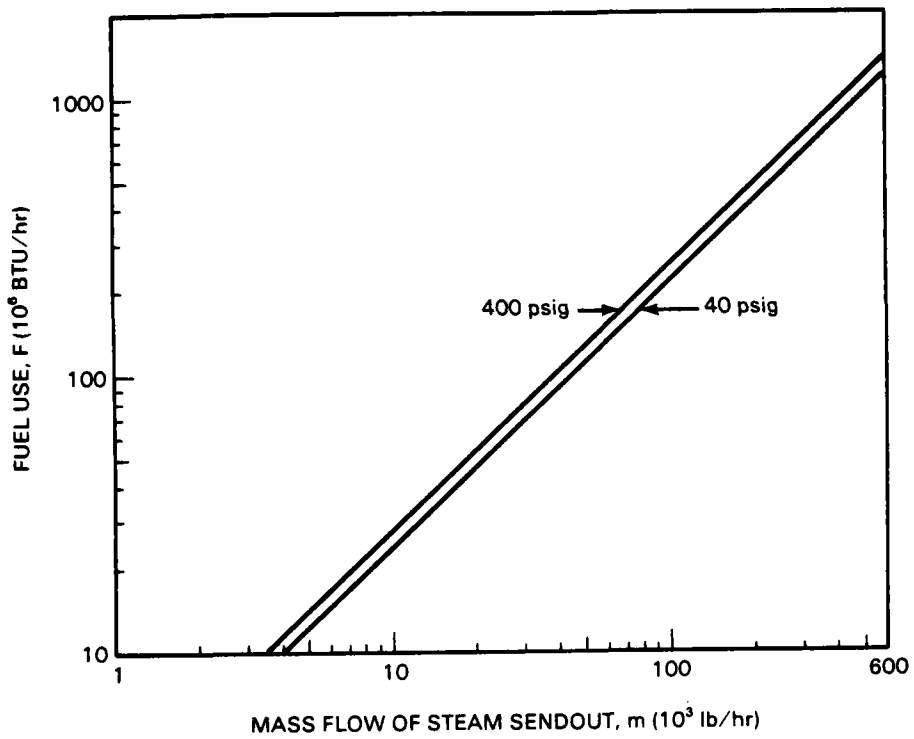

FIGURE 3.8. Gas Turbine Fuel Use

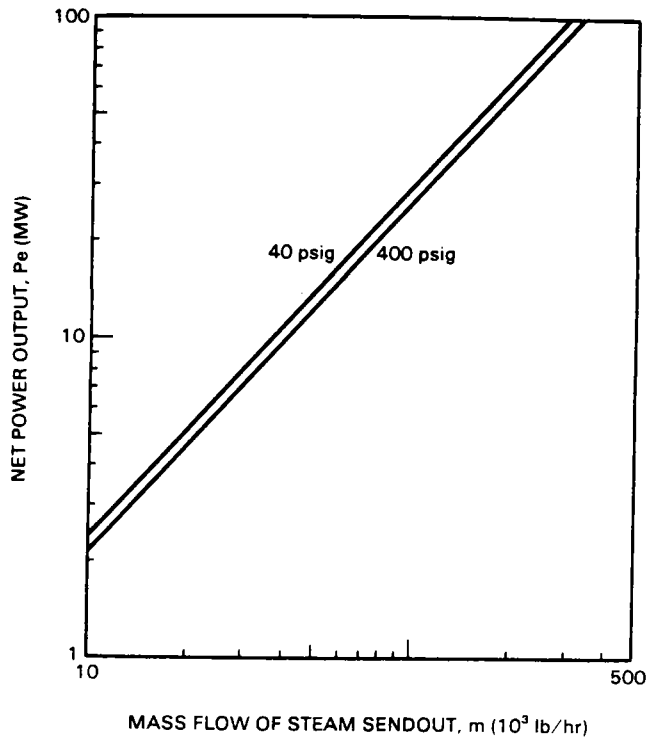

FIGURE 3.9. Combined-Cycle Power Output

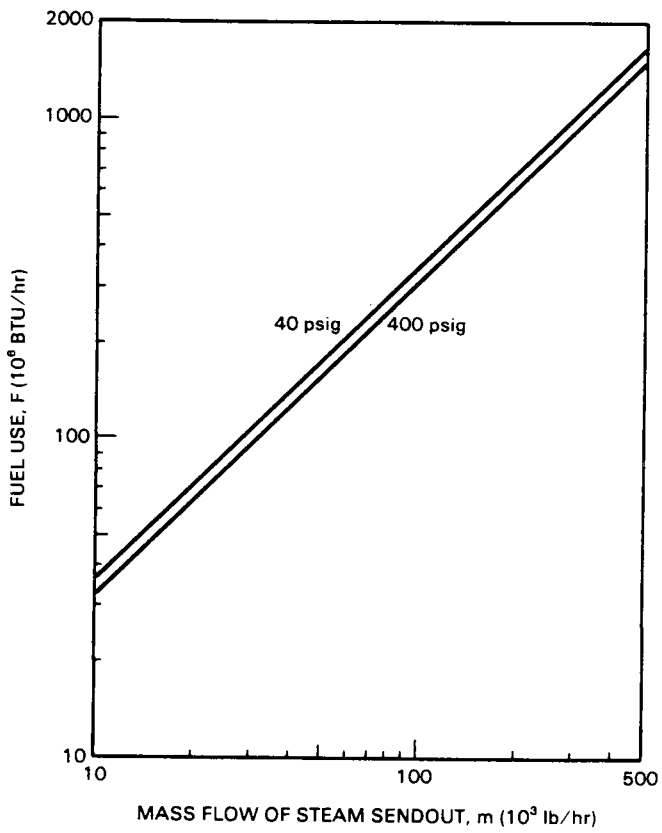

FIGURE 3.10. Combined-Cycle Fuel Use

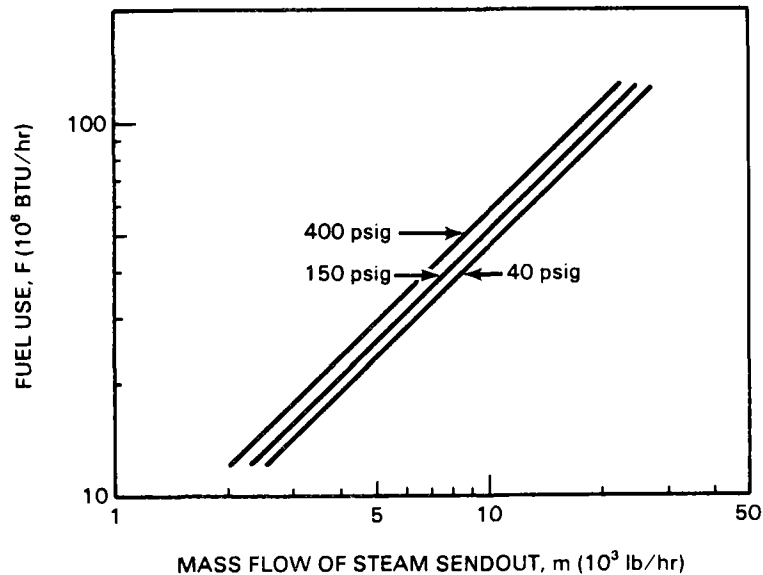
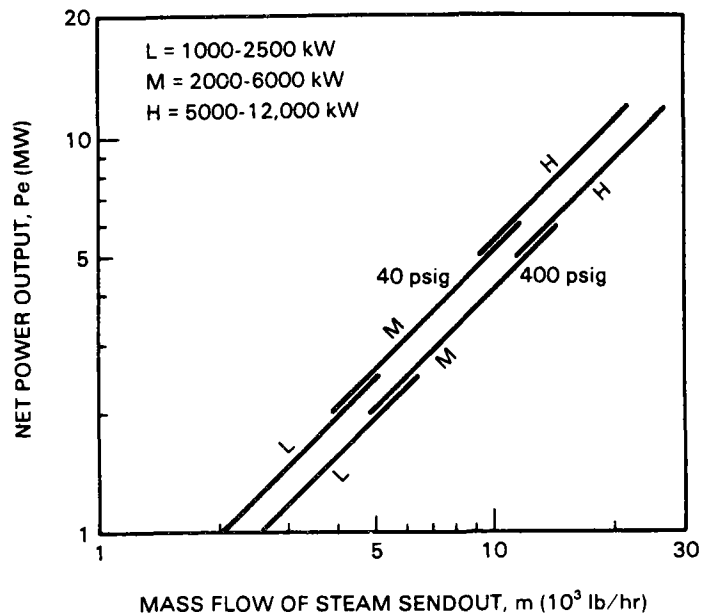

FIGURE 3.11. Diesel Power Output and Fuel Use

sendout pressure,  $p_1$ , based on the assumptions listed in Appendix D. These performance characteristics are read from the curves for each steam sendout mass flow rate,  $m$ , recorded in Table 2.4 and each steam sendout pressure,  $p_1$ , recorded in Table 2.2. If the steam sendout mass flow rate exceeds the range of the graph, multiple prime mover units will be required to achieve the desired steam sendout. The optimal size of each unit must be determined from an economic analysis.

Table 3.2 provides a format for recording the performance characteristics of the standard topping configurations. The power-to-heat ratio, fuel-use efficiency, and the incremental heat rate are derived from  $H$ ,  $P_e$ , and  $F$  as shown in Table 3.2. Table 3.3 shows an example of a completed table for the finishing mill.

The power-to-heat ratio of each configuration provides the following useful information when compared to the plant power-to-heat ratio calculated earlier in Section 2.2:

TABLE 3.2. Performance Characteristics of Standard Topping Configurations

PRIME MOVER		H <sup>(a)</sup> HEAT CONTENT OF STEAM SENDOUT (10 <sup>6</sup> BTU/hr)	P <sub>e</sub> <sup>(b)</sup> NET POWER OUTPUT (MW)	F <sup>(c)</sup> FUEL USE (10 <sup>6</sup> BTU/hr)	POWER/HEAT <sup>(d)</sup> RATIO (kWh/10 <sup>6</sup> BTU)	η <sub>f</sub> <sup>(e)</sup> FUEL UTILIZATION	i <sub>hr</sub> <sup>(f)</sup> INCREMENTAL HEAT RATE (BTU/kWh)
STEAM TURBINE	STEAM 1						
	STEAM 2						
	STEAM 3						
	TOTAL						
GAS TURBINE	STEAM 1						
	STEAM 2						
	STEAM 3						
	TOTAL						
COMBINED CYCLE	STEAM 1						
	STEAM 2						
	STEAM 3						
	TOTAL						
DIESEL ENGINE	STEAM 1						
	STEAM 2						
	STEAM 3						
	TOTAL						

<sup>(a)</sup>FROM TABLE 2.3

<sup>(b)</sup>USE STEAM PRESSURE AND STEAM MASS FLOW RATE FROM TABLE 2.2 TO READ POWER OUTPUT OF STEAM TURBINE FROM FIGURE 3.5, GAS TURBINE FROM FIGURE 3.7, COMBINED CYCLE FROM FIGURE 3.9, AND DIESEL ENGINE FROM FIGURE 3.11

<sup>(c)</sup>USE STEAM PRESSURE AND MASS FLOW RATE FROM TABLE 2.2 TO READ FUEL USE FOR STEAM TURBINE FROM FIGURE 3.6, GAS TURBINE FROM FIGURE 3.8, COMBINED CYCLE FROM FIGURE 3.10 AND DIESEL FROM FIGURE 3.11

<sup>(d)</sup>POWER/HEAT RATIO = P<sub>e</sub> (1000)/H

<sup>(e)</sup>η<sub>f</sub> = [P<sub>e</sub> (1000)(3413) + H] / F

<sup>(f)</sup>i<sub>hr</sub> = [F - H/η<sub>b</sub>] / [P<sub>e</sub> (1000)]

- If the plant power-to-heat ratio is greater than that of the cogeneration system, the cogeneration system will generate less electricity than is needed by the plant.
- If the power-to-heat ratio is less than that of the cogeneration system, the cogeneration system will generate more electricity than is needed by the plant.

The incremental heat ratio will be used in the next chapter to establish a preliminary rank ordering of the configurations.

### 3.3 TOPPING CONFIGURATIONS FOR VARIABLE HEAT DEMANDS

Cogeneration plant sizing is straightforward (as shown in Table 3.3) if the steam demand (lb/hr) remains constant over extended periods of time. This is the case in many industries where heat demands vary only slightly from the average design values. When the heat demand varies greatly, the

topping systems can be modified to accommodate changing sendout conditions. This section will describe some methods available to vary the power/heat ratio generated by typical topping units. Maintaining operation of the prime mover as closely as possible at design-point efficiency, despite changes in heat demand is important. Keeping increases in specific fuel consumption or exhaust-gas temperature within limits is particularly important for gas turbines.

The efficiency of steam turbine changes little for part-load conditions. Typically, 55% of the total steam throughput is required at 50% part load (i.e., only a 10% loss in efficiency). Therefore, steam turbines can track varying steam demands with smaller penalties in fuel consumption than gas turbines and diesels.

A unit topping a varying steam demand must be able to change its power-to-heat ratio. Some examples of configurations that permit such variations from their design values are as follows:

TABLE 3.3. Performance Characteristics of Standard Topping Configurations for the Textile Finishing Plant

PRIME MOVER		H <sup>(a)</sup> HEAT CONTENT OF STEAM SENDOUT (10 <sup>6</sup> BTU/hr)	Pe <sup>(b)</sup> NET POWER OUTPUT (MW)	F <sup>(c)</sup> FUEL USE (10 <sup>6</sup> BTU/hr)	POWER/HEAT <sup>(d)</sup> RATIO (kWh/10 <sup>6</sup> BTU)	η <sub>f</sub> <sup>(e)</sup> FUEL UTILIZATION	ih <sub>r</sub> <sup>(f)</sup> INCREMENTAL HEAT RATE (BTU/kWh)
STEAM TURBINE	STEAM 1	42.3	1.6	58	37.8	0.823	5147
	STEAM 2	133.8	4.6	170	34.4	0.879	2737
	STEAM 3						
	TOTAL	176.1	6.2	228	35.2	0.865	3359
GAS TURBINE	STEAM 1	42.3	5.6	89	132.4	0.690	7006
	STEAM 2	133.8	20.0	270	149.5	0.748	5629
	STEAM 3						
	TOTAL	176.1	25.6	359	145.4	0.734	5931
COMBINED CYCLE	STEAM 1	42.3	10.0	131	236.4	0.583	3124
	STEAM 2	133.8	36.0	408	269.1	0.639	6961
	STEAM 3						
	TOTAL	176.1	46.0	539	261.2	0.618	7214
DIESEL ENGINE	STEAM 1						
	STEAM 2						
	STEAM 3						
	TOTAL						

<sup>(a)</sup>FROM TABLE 2.3

<sup>(b)</sup>USE STEAM PRESSURE AND STEAM MASS FLOW RATE FROM TABLE 2.2 TO READ POWER OUTPUT OF STEAM TURBINE FROM FIGURE 3.5, GAS TURBINE FROM FIGURE 3.7, COMBINED CYCLE FROM FIGURE 3.9, AND DIESEL ENGINE FROM FIGURE 3.11

<sup>(c)</sup>USE STEAM PRESSURE AND MASS FLOW RATE FROM TABLE 2.2 TO READ FUEL USE FOR STEAM TURBINE FROM FIGURE 3.6, GAS TURBINE FROM FIGURE 3.8, COMBINED CYCLE FROM FIGURE 3.10 AND DIESEL FROM FIGURE 3.11

<sup>(d)</sup>POWER/HEAT RATIO = Pe (1000)/H

<sup>(e)</sup>η<sub>f</sub> = [Pe (1000)(3413) + H] / F

<sup>(f)</sup>ih<sub>r</sub> = [F - H/η<sub>b</sub>] / [Pe (1000)]

- a back-pressure steam turbine with an additional boiler at the pressure level of the process steam. (In retrofit situations, the boiler can be one of the existing process-steam generators.)
- an extraction/condensing steam turbine.
- a gas turbine with supplemental firing. (A diesel can be substituted.)

These configurations and the effects on their performance of varying the heat content of the steam sendout are shown in Figure 3.12. The back-pressure turbine has a smaller incremental heat rate than the extraction/condensing turbine. At maximum steam extraction, a minimum steam flow must still be maintained through the condensing stages of the extraction/condensing turbine, which drives up the heat rate for power generation. Increasing steam extraction reduces the incremental heat rate until the maximum steam extraction rate is reached. For all other candidates, the incremental

heat rate increases whether the heat demand increases or decreases. Fuel-use efficiency decreases in all cases for any excursion from the design point.

In summary:

- Substantial peak demands for heat should not be met by the cogeneration unit.
- Sizing of the prime mover is least critical in the case of the steam turbine, but quite critical for the gas turbine. Oversizing will result in elevated stack-gas temperatures and the concomitant energy losses.

### 3.4 LOAD-DURATION CURVES AND SYSTEM MATCHING

Where steam demand is fairly constant and variations occur only occasionally, the increase in incremental heat rate over the year will have only a modest effect. The sizing of the topping unit becomes quite

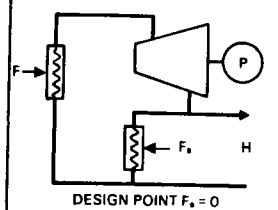
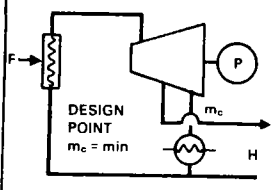
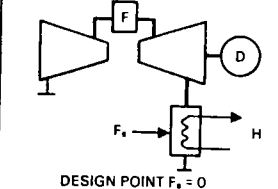
		H DECREASES				H INCREASES			
		P	F	ihr	$\eta_r$	P	F	ihr	$\eta_r$
STEAM TURBINES	 <p>BACK-PRESSURE TURBINE WITH LOW-PRESSURE BOILER DESIGN POINT <math>F_s = 0</math></p>	DECREASE	DECREASE	CONSTANT	CONSTANT	CONSTANT	INCREASE (F <sub>s</sub> IS ADDED)	INCREASE	DECREASE
	 <p>EXTRACTION/CONDENSING TURBINE DESIGN POINT <math>m_c = \min</math></p>	INCREASE	CONSTANT	INCREASE	DECREASE	DECREASE	CONSTANT	DECREASE	DECREASE
GAS TURBINES OR COMBINED CYCLE	 <p>GAS TURBINE WITH WASTE HEAT BOILER AND SUPPLEMENTAL FIRING DESIGN POINT <math>F_s = 0</math></p>	CONSTANT	CONSTANT	INCREASE	DECREASE	CONSTANT	INCREASE (F <sub>s</sub> IS ADDED)	INCREASE	DECREASE

ihr = INCREMENTAL HEAT RATE  
 $\eta_r$  = FUEL UTILIZATION

FIGURE 3.12. Sample Configurations for Changing Heat Demand

critical, however, where steam demand variations are substantial. This can be the case in midsize industries that do not operate three shifts per day on all processes throughout the year, or where weather-dependent nonprocess loads have to be met by the central plant.

The top of Figure 3.13 shows an example of large changes in heat and power demands with the seasons; moreover, coincidence between power and heat demands is quite poor. By determining the average steam demands (lb/hr) for given time intervals (for instance, months) and arranging them in declining order, a load-duration curve can be developed (Figure 3.13, bottom). The load-duration curve indicates the number of hours during which a given steam demand is exceeded. Figure 3.13 also contains the load-duration curve for the power demand, plotted in the opposite direction. The load-duration curve for the steam demand is an excellent tool to assess the performance of cogeneration units of different types and sizes.

One possible way of maintaining the steam load-duration curve in summer months is by using adsorption air conditioning.

The areas under the load-duration curves for heat demand,  $H$  ( $10^6$  Btu/yr), fuel consumption,  $F$  ( $10^6$  Btu/yr), and net power generation,  $P_e$  (kWh/yr) provide the following:

- the annual heat sendout to the process,  $H_a$  ( $10^6$  Btu/yr)
- the annual fuel consumption for the turbine and supplemental firing,  $F_a$  ( $10^6$  Btu/yr)
- the annual net power generation,  $P_{ea}$  (kWh/year).

These three values can be combined to determine an average value for the incremental heat rate:

$$(ihr)_{av} = (F_a - H_a/0.85)/P_{ea}$$

### 3.5 NOMENCLATURE

p	steam pressure	psig
T	temperature	°F
h	enthalpy	Btu/lb

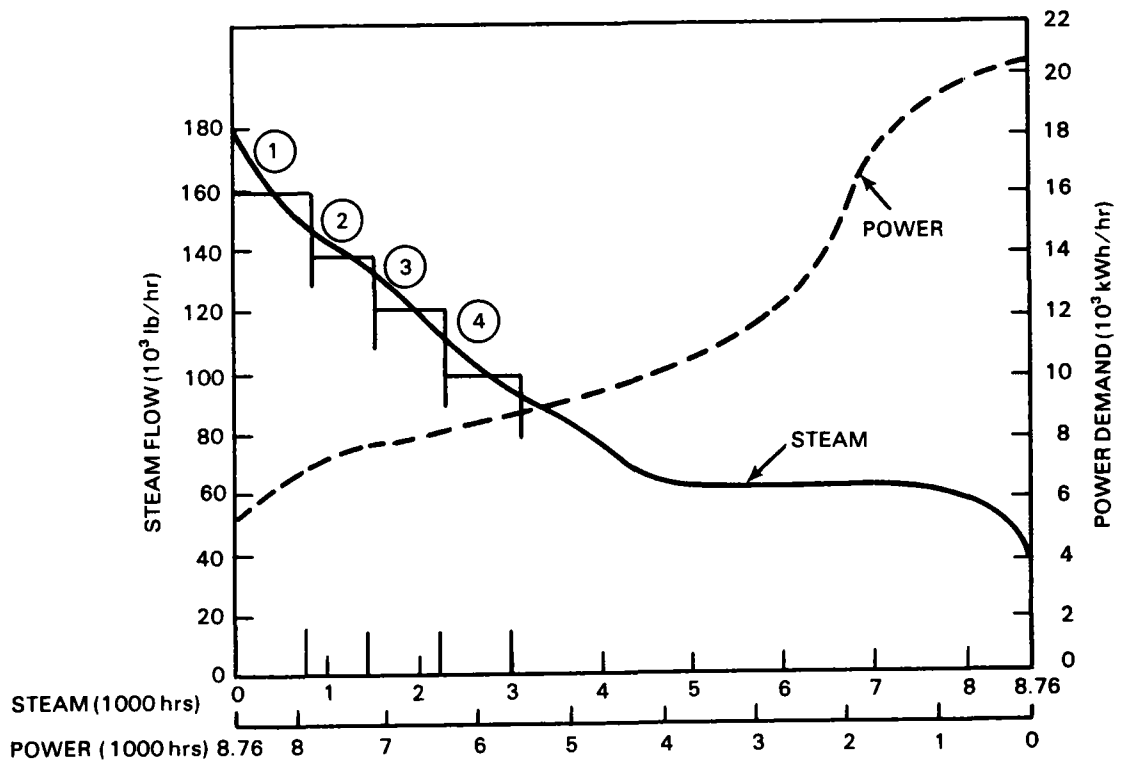
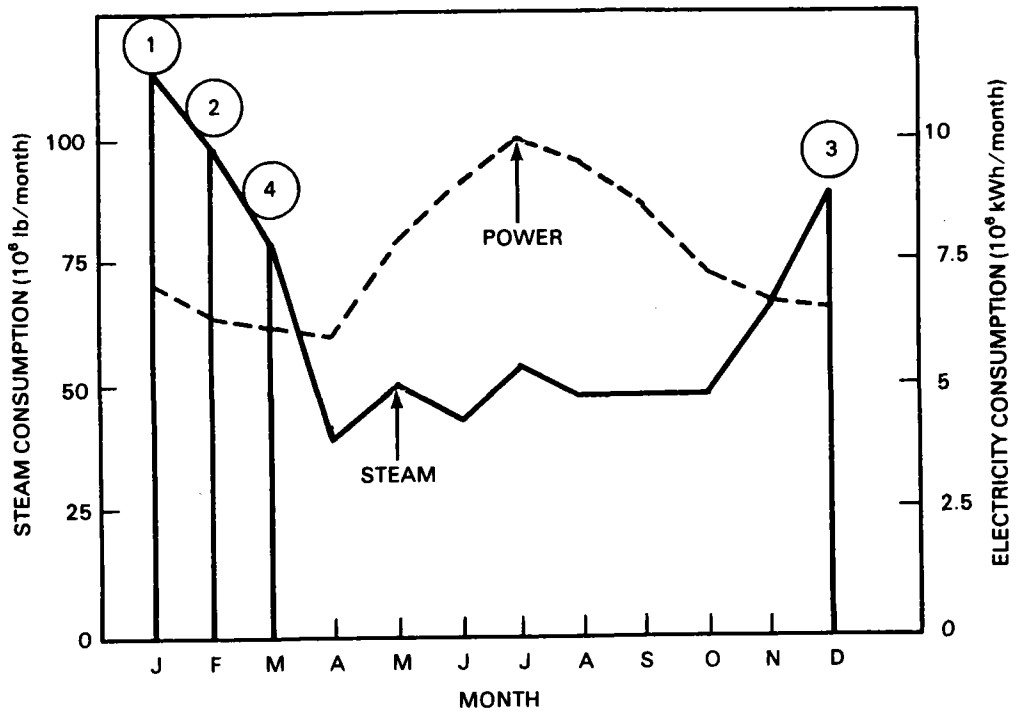

FIGURE 3.13. Development of a Load-Duration Curve



$m$	mass flow of steam sendout	lb/hr
$m_g$	mass flow of exhaust gases	lb/hr
$T_{amb}$	ambient temperature	$^{\circ}F$
$P$	shaft-power generated	kW
$H$	heat content of steam sendout	Btu/hr
$F$	fuel consumption	Btu/hr
$P_e$	net power output	MW
$\eta_t$	turbine efficiency	%
$\eta_b$	boiler efficiency	%
$\eta_e$	heat-exchanger efficiency	%
$\eta_f$	fuel-use efficiency	%
$\eta_c$	power conversion efficiency	%
$P_e/H$	power/heat ratio	kWh/10 <sup>6</sup> Btu
ih <sub>r</sub>	incremental heat rate	Btu/kWh
$C_p$	heat capacity	Btu/lb $^{\circ}F$

a/f	air-to-fuel ratio
HV	heating value of fuel Btu/lb
HR	heat rate Btu/kWh

Local enthalpy state points in steam cycle:

$h_0$	throttle conditions
$h_1$	sendout conditions
$h_2$	condensate return
$h_3$	after deaerator
$h_4$	at boiler inlet
$h_5$	before superheater
$h_1^*$	ideal isentropic expansion from $h_0$
$h_1'$	before desuperheater

#### REFERENCES

1. TRW Energy Engineering Division. 1981. Handbook of Industrial Cogeneration. DOE/TIC-11605. McLean, Virginia.
2. Office of Technology Assessment. 1983. Industrial and Commercial Cogeneration. Congress of the United States, Washington, D.C.

## 4.0 ECONOMIC ANALYSIS

Establishing the performance of a cogeneration system is an essential first step toward determining the most cost-effective system. However, choosing the best cogeneration unit depends on economic considerations.

An economic analysis is needed for two reasons: 1) to determine whether cogeneration is worth undertaking, and 2) to determine which of several cogeneration configurations is best. Although the resulting decisions in both cases usually involve judgments of factors other than those included in the economic analysis, that analysis provides essential information in an organized, systematic framework that strongly influences those decisions.

The basic steps in the economic analysis presented in this chapter are as follows:

1. perform preliminary rank ordering
2. estimate the investment cost of the cogeneration system
3. estimate the first-year operating costs
4. develop cash-flow summaries based on power and fuel cost escalation estimates
5. calculate measures of economic worth
6. analyze sensitivity
7. determine impact of tax parameters.

Appendix E describes some of the basic concepts and terminology often associated with discussions of project economics.

### 4.1 PRELIMINARY RANK ORDERING

A preliminary rank ordering of the standard cogeneration configurations can be achieved by establishing the break-even points between first-year fuel costs and cogenerated electricity costs as a function of incremental heat rate. This preliminary rank ordering is useful because it excludes unrealistic configurations at an early stage.

The first step in the rank-ordering process is to recognize that three possible operating scenarios are available to the plant:

1. Cogenerate into plant load and purchase additional power needs from the utility.

2. Cogenerate into plant load and sell excess power to the utility.
3. Sell all cogenerated power to the utility and simultaneously purchase plant power needs.

The last possibility, simultaneous sale and purchase, is only of interest if the avoided cost exceeds the local industrial electricity price level. The first two possibilities are mutually exclusive and are dependent on the relationship between the power-to-heat ratio calculated for the plant demand and the power-to-heat ratios generated by each of the cogeneration configurations as discussed in Section 3.2. In the first two cases, to be economically viable, power must be cogenerated at costs that are competitive with the cost of power purchased from the central power station. In the third case, the cost to cogenerate the power must be less than or equal to the avoided cost or the negotiated rate at which the utility will purchase cogenerated power.

The second step in the rank-ordering process uses Figure 4.1 to establish the break-even points between first-year fuel costs and cogenerated electricity costs as a function of the incremental heat rate. For a given fuel price, the cogenerated electricity costs increase proportionally with the incremental heat rate (Figure 4.1). The energy manager should first draw horizontal lines across Figure 4.1 at the local industrial electricity price level and at the avoided cost. These lines contain the locus of all break-even fuel prices for the three options. Next, a vertical line should be drawn for each incremental heat rate shown in Table 3.2 up to the fuel price levels. At this price level, a horizontal line should be drawn to determine the cogenerated electricity cost for the particular prime mover-fuel combination. The margin indicated between the cogenerated electricity cost and either the cost of purchased electricity or the avoided cost represents the savings available to cover operating and maintenance (O&M) costs and to recover the capital investment required for constructing the cogeneration plant. The prime mover-fuel combinations can now be ranked by these savings margins, and losing combinations can be excluded prior to the economic analysis.

A sample rank ordering for the candidate configurations for the textile finishing mill is presented in Figure 4.2.

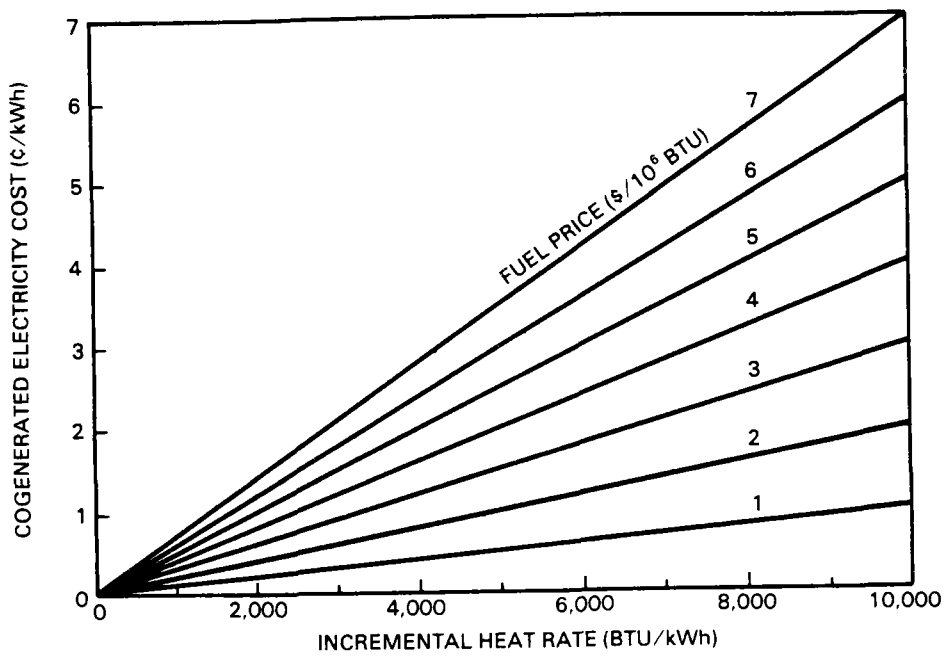

FIGURE 4.1. Cogenerated Electricity Cost as a Function of Incremental Heat Rate for Various Fuel Prices

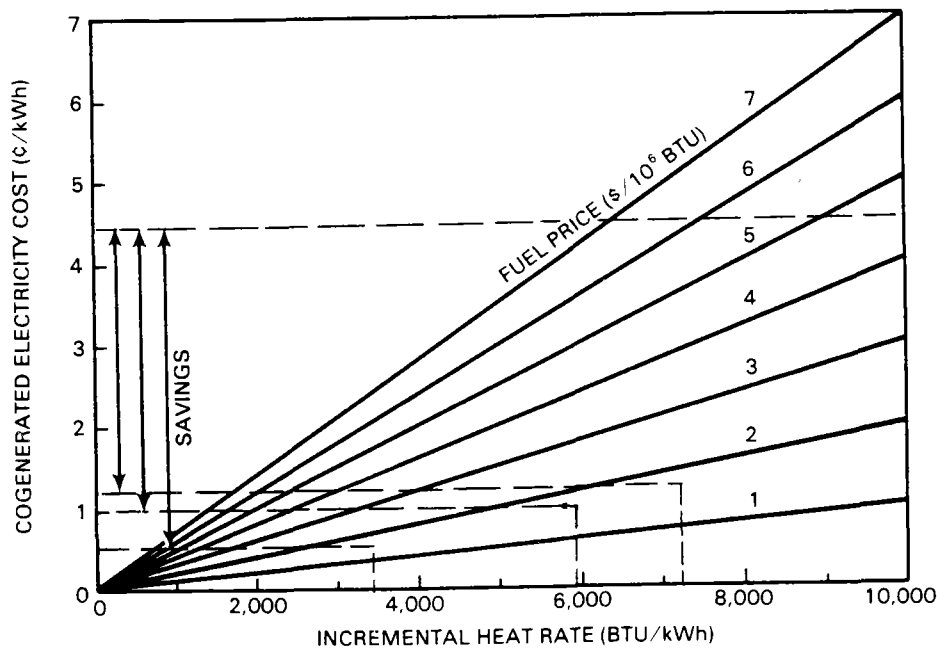

FIGURE 4.2. Preliminary Rank Ordering for the Textile Finishing Mill

## 4.2 ESTIMATE INVESTMENT COSTS

Obtaining a predesign estimate of the investment cost is the next step in conducting a preliminary assessment of the economics of cogeneration. For this initial investment analysis, the turnkey cost of a cogeneration system can be estimated in one of two ways. The estimated costs of major equipment items can be totalled and then cost factors can be applied to account for installation and indirect construction costs. Or, cost data from current publications can be used. Several recent publications contain estimates of cogeneration system costs. Some of these estimates are reproduced in Appendix F. If published cost data are used, they may need to be adjusted to current price levels, as discussed in Section 4.2.2.

Table 4.1 lists the major cost items for a cogeneration system. The costs can be classified as purchased equipment costs, installation costs, balance-of-plant costs, and indirect costs. The basic framework for estimating the total investment cost from the purchased equipment cost is provided in

TABLE 4.1. Major Cost Items for a Cogeneration System

### PURCHASED EQUIPMENT COSTS

- Fuel Handling and Storage
- Fuel Use - Boilers
- Energy Conversion - Turbine Generators, Engines
- Pollution Control
- Major Electrical - Switch Gear, Transformers

### PURCHASED EQUIPMENT INSTALLATION COSTS

- Installation Labor
- Structural Supports, Insulation, Paint

### BALANCE-OF-PLANT COSTS

- Instrumentation and Controls
- Piping
- Ancillary Electrical Equipment
- Buildings
- Yard Improvements
- Service Facilities
- Land

### INDIRECT COSTS

- Engineering and Supervision
- Construction Expenses
- Contractor's Fee
- Contingency

Table 4.2. The total investment cost is estimated as follows:

1. Update purchased equipment cost to current-year price levels (if necessary).
2. Determine installed equipment cost.
3. Determine balance-of-plant cost.
4. Determine total direct cost.
5. Determine total investment cost.

Sources of equipment costs, methods of adjusting costs for capacity, methods of estimating auxiliary equipment costs, and methods of updating costs to current-year price levels are discussed in this section.

### 4.2.1 Purchased Equipment Costs

Major cogeneration equipment can be conveniently divided into the following groups: 1) fuel-handling and storage equipment, 2) fuel-use equipment, 3) energy-conversion equipment, 4) pollution-control equipment, and 5) major electrical equipment.

The most accurate equipment costs are firm bids from fabricators or suppliers. Often, fabricators can supply quick estimates that are close to the bid price. Second best in reliability are costs from past purchase orders. When used for pricing new equipment, purchase-order prices must be adjusted to current dollars using a cost index as discussed in Section 4.2.2. Information on process equipment costs is also published in engineering journals. If the published information is for equipment of a different size or capacity, costs can be scaled to the desired capacity using a scaling factor as follows:

$$\text{Cost of Equipment A} = (\text{Cost of Equipment B}) \left( \frac{\text{Capacity A}}{\text{Capacity B}} \right)^n$$

Suggested values for  $n$  are 0.87 for boilers, and 0.75 for steam turbines and other equipment.

The potential cogenerator should consider the possibility of incorporating used equipment components in the cogeneration system. Used equipment offers the advantage of lower initial costs and may be available from small utility plants that are being retired or from other industrial plants.

TABLE 4.2. Cogeneration System Investment Estimate

STEP 1: UPDATE COSTS TO CURRENT YEAR

PURCHASED EQUIPMENT COST, \$	X	COST INDEX RATIO (CURRENT YEAR/COST YEAR)	=	(E) CURRENT PURCHASED EQUIPMENT COST, \$

STEP 2: DETERMINE INSTALLED EQUIPMENT COST

E	X	INSTALLATION COST FACTOR	=	(I) INSTALLED EQUIPMENT COST, \$

STEP 3: DETERMINE BALANCE-OF-PLANT COST

E	X	BALANCE-OF-PLANT COST FACTOR	=	(B) BALANCE-OF-PLANT COST, \$

STEP 4: DETERMINE TOTAL DIRECT COST

B	+	I	=	(D) TOTAL DIRECT COST \$

STEP 5: DETERMINE TOTAL INVESTMENT COST

D	X	INDIRECT COST FACTOR	=	TOTAL INVESTMENT COST, \$

4.2.2 Cost Indexes

Some cost data available for predesign cost estimates are from older projects and may be out-of-date. Cost indexes can be used to convert old costs to present-day costs as follows:

$$\text{Current Cost} = \text{Original Cost} \times \frac{\text{index value at current time}}{\text{index value at original time}}$$

One such index is the Chemical Engineering plant construction cost index, which is published biweekly in Chemical Engineering. All index components are based on 1957-1959 = 100.

4.2.3 Cost Factors

With the estimate of the purchased equipment cost obtained from one of the sources discussed above, an estimate of the total investment cost can be derived. This is done by multiplying the purchased cost by cost factors that account for installation costs, balance-of-plant costs, and indirect costs.

The best source of these cost factors is data from recently constructed plants that are similar in configuration. Table 4.3 lists some average cost factors from the literature. (1,2)

**TABLE 4.3. Average Cost Factors**

Item	Cost Factor
Installation	1.4 - 1.5
Balance-of-Plant	2.2 - 3.0
Indirect Costs	1.25 - 1.4

**4.3 OPERATING AND MAINTENANCE COSTS**

In addition to the capital cost of the cogeneration system, operating and maintenance (O&M) costs must be determined to fully analyze the economics of cogeneration. The relevant O&M costs discussed in this section are the fuel cost, the electricity cost (or revenue), and the labor and overhead costs associated with operating and maintaining the system.

**4.3.1 Fuel Cost**

The cost of fuel is a dominant factor in the operating costs of a cogeneration system because the plant may burn more fuel when

generating its own electricity. However, using new high-efficiency (85%) boilers for the cogeneration case compared to existing boilers with a lower efficiency (70%) for the base case may lead to an incremental fuel savings for the cogeneration case. Table 4.4 provides a format for calculating the annual fuel cost for cogeneration and for the base case. A sample calculation for the finishing mill is shown later in the chapter.

To determine the annual cost of fuel with cogeneration, the annual fuel use is multiplied by the local fuel price. The annual fuel use includes the fuel used in the cogeneration unit as well as fuels used for direct-heating applications in the plant. In Table 3.2 the fuel consumption, F, ( $10^6$  Btu/hr), was calculated for the cogeneration system. This must be converted to an annual figure by multiplying by the number of hours of operation per year (load factor). The annual fuel use and the fuel price must be in consistent units to determine the annual fuel cost.

**TABLE 4.4. Fuel Cost Calculations**

**FUEL COST WITH COGENERATION:**

FUEL USE, F ( $10^6$ BTU/HR)	X	LOAD FACTOR (HRS/YR)	X	FUEL PRICE (\$/ $10^6$ BTU)	=	ANNUAL FUEL COST (\$/YR)
<b>TOTAL A</b>						

**FUEL COST WITHOUT COGENERATION:**

FUEL TYPE	FUEL USE (UNITS/YR)	X	FUEL PRICE (\$/UNIT)	=	ANNUAL FUEL COST (\$/YR)
<b>TOTAL B</b>					

**INCREMENTAL FUEL COST = A-B =**

--

The annual fuel cost for the base case is determined by multiplying the price of each fuel by its annual use. This includes fuels used for both direct- and indirect-heating operations. The annual fuel usage for each type of fuel can be obtained from Table 2.1.

To determine the incremental fuel cost, the fuel cost for the reference case is subtracted from the cogeneration fuel cost, as shown in Table 4.4.

#### 4.3.2 Electricity Cost or Revenue

To determine the electricity cost or revenue, again the three cases outlined in Section 4.1 must be considered.

As mentioned previously, simultaneous sale and purchase is only of interest if the avoided cost exceeds the purchase price of power. In the first case, an expense is incurred because additional power beyond the amount cogenerated must be purchased to meet the plant demand. In the latter two cases, revenue is realized either through the sale of excess power or of all cogenerated power to the utility.

Table 4.5 provides a format for calculating the incremental electricity savings from cogeneration. A sample calculation for the finishing mill is shown later in the chapter.

First, the cost of electricity for the base case is found by multiplying the annual usage (from Table 2.1) by the purchased electric rate. Then, the cost or revenue with cogeneration is calculated. The power generated by the cogeneration system,  $P_e$ , was calculated in Table 3.2. This is converted to an annual consumption figure (kWh/yr) by multiplying by the load factor and by 1000. Next, if the cogeneration system is to cogenerate into the plant load, the annual plant use (A) is subtracted from the amount of electricity cogenerated (B) to yield the amount that must be purchased (negative value) or the amount of excess that can be sold to the utility (positive value). If additional electricity must be purchased, the annual electricity cost is found by multiplying the deficit D (if negative) by the electric rate. If excess electricity is to be sold, the annual electricity revenue is found by multiplying the excess D (if positive) by the avoided cost or the negotiated purchase price.

If all of the electricity cogenerated is to be sold to the utility and the total plant electricity demand purchased simultaneously, the annual electricity revenue is the product of the annual electricity cogenerated (C) and the avoided cost or the negotiated

purchase price. The incremental savings is the annual base-case purchased electricity cost (A) plus the annual purchased electricity cost, which is negative, or the annual electricity revenue with cogeneration (E).

#### 4.3.3 Other O&M Costs

In addition to fuel and electricity costs, other O&M costs, such as operating labor, annual routine maintenance, and overhead charges for administrative and support labor, should be considered. Again, the incremental cost is the difference between these costs with cogeneration and the base case.

These costs are highly plant specific and depend on the cogeneration configuration selected and the fuel used. Appendix G provides some average values for the O&M costs of a cogeneration system.<sup>(3)</sup>

#### 4.4 COGENERATION PROJECT CASH FLOWS

After identifying the relevant costs, the next step is to determine the amount and timing of the cash flows. It is important to determine the timing of each cost and revenue because of the time value of money.

For most investment projects, large cash outflows occur during the construction years and perhaps the first few years of operation. Once the cogeneration system is operating, smaller cash outflows or even inflows can be expected. Finally, at the end of the project life, the salvage value of the equipment represents a cash inflow.

Because costs are occurring over a period of several years, the escalation of costs must be taken into account. The best source of information on future fuel or electricity costs is usually the plant's electric utility or fuel supplier, and the public utility commission for avoided costs.

In some cases, historical data may be helpful. Table 4.6 shows the relative costs for fuels from 1973 to 1982. Escalation rates for these fuels have been estimated by the DOE<sup>(5)</sup> (Table 4.7). The DOE has also made estimates on a regional basis. Other organizations, such as the Gas Research Institute and the Electric Power Research Institute, have also made estimates, although these estimates do not always agree. Replacement equipment and labor can also be expected to fluctuate with time. According to the Marshall and Swift Index<sup>(6)</sup> (Table 4.8), equipment costs in the U.S. have escalated from an index of 332.0 in 1972 to 745.6 in 1982. Labor during the same period escalated from average hourly

TABLE 4.5. Electricity Cost/Revenue Calculations

I. BASE CASE ELECTRICITY COST

(A) ANNUAL USE (kWh/YR)	X	ELECTRIC RATE (\$/kWh)	=	(B) ANNUAL PURCHASED ELECTRICITY COST (\$/YR)

ELECTRICITY COGENERATED (MW)	X	LOAD FACTOR (HOURS/YR)	X	1000 kW MW	=	(C) ANNUAL ELECTRICITY COGENERATED (kWh/YR)

II. COGENERATING INTO PLANT LOAD

C	-	A	=	(D) ELECTRICITY DEFICIT OR EXCESS (kWh/YR)

CASE 1: IF D IS NEGATIVE (DEFICIT), PURCHASE EXCESS POWER:

D	X	ELECTRIC RATE (\$/kWh)	=	(E) ANNUAL PURCHASED ELECTRICITY COST (\$/YR)

CASE 2: IF D IS POSITIVE (EXCESS), SELL EXCESS POWER:

D	X	AVOIDED COST (\$/kWh)	=	(E) ANNUAL ELECTRICITY REVENUE (\$/YR)

INCREMENTAL SAVINGS

B	+	E	=	INCREMENTAL SAVINGS (\$/YR)

III. SIMULTANEOUS SALE AND PURCHASE

C	X	AVOIDED COST- ELECTRIC RATE (\$/kWh)	=	INCREMENTAL SAVINGS (\$/YR)

earnings of \$4.09 for manufacturing employees in 1973 to average hourly earnings of \$8.50 in 1982 (Table 4.9). The escalation rates for these parameters may vary during the investment life of a cogeneration system. Labor contracts with unions, company projections of wage increases, and overall inflation rates are some of the guides that of wage increases, and overall inflation rates are some of the guides that might help determine future labor costs. The vendors

of equipment used in the cogeneration system would be good sources of estimates of future equipment costs.

Table 4.10 provides a format for summarizing cash flows, either for each alternative or incrementally. The present-year costs that were estimated earlier can simply be multiplied by escalation rates to obtain the estimated costs for the year the cash flows occur.



TABLE 4.6. Relative Costs for Fuels<sup>(4)</sup>

Year	Electricity <sup>(a)</sup> (\$/kWh)	Distillate <sup>(b)</sup> Fuel Oil (\$/Barrel)	Residual <sup>(c)</sup> Fuel Oil (\$/Barrel)	Natural Gas <sup>(d)</sup> (\$/1000 ft)	Coal <sup>(e)</sup> (\$/10 Btu)
1973	1.25	N/A	5.03	0.35	0.41
1974	1.69	26.9	11.95	0.49	0.71
1975	2.07	31.2	13.20	0.77	0.81
1976	2.21	40.6	11.49	1.06	0.85
1977	2.50	46.0	13.23	1.39	0.95
1978	2.79	49.4	12.75	1.48	1.12
1979	3.05	65.6	18.67	1.80	1.22
1980	3.69	97.8	26.09	2.28	1.35
1981	4.29	120.5	32.50	2.91	1.53
1982	4.95	118.6	29.08	3.49	1.65

(a) Industrial rate (retail) for privately owned utilities.

(b) No. 2 heating oil average retail.

(c) No. 6 residual oil average retail.

(d) Average delivered to electric plants.

(e) Cost to steam-electric utility.

TABLE 4.7. Escalation of Fuel Costs for Industrial Sector<sup>(5)</sup>

Form of Energy	Estimated Real Escalation Rate (%) (1985-1990)
Electricity <sup>(a)</sup>	8
Distillate Fuel Oil	44
Residual Fuel Oil	
High Sulfur	55
Low Sulfur	48
Natural Gas	29
Steam Coal	11

(a) Not applicable to avoided cost that is utility-dependent.

TABLE 4.8. Relative Cost Increases for Equipment  
(Marshall and Swift Index)<sup>(6)</sup>

Year	Equipment Cost
1972	332.0
1973	344.1
1974	398.4
1975	444.3
1976	472.1
1977	505.4
1978	545.3
1979	599.4
1980	659.6
1981	721.3
1982	745.6



TABLE 4.11. Cogeneration System Investment Estimate for Textile Finishing Mill Example

STEP 1: UPDATE COSTS TO CURRENT YEAR

PURCHASED EQUIPMENT COST, \$	X	COST INDEX RATIO (CURRENT YEAR/COST YEAR)	=	(E) CURRENT PURCHASED EQUIPMENT COST, \$
3.42x10 <sup>6</sup>		1.214		4.15x10 <sup>6</sup>

STEP 2: DETERMINE INSTALLED EQUIPMENT COST

E	X	INSTALLATION COST FACTOR	=	(I) INSTALLED EQUIPMENT COST, \$
4.15x10 <sup>6</sup>		1.45		6.02x10 <sup>6</sup>

STEP 3: DETERMINE BALANCE-OF-PLANT COST

E	X	BALANCE-OF-PLANT COST FACTOR	=	(B) BALANCE-OF-PLANT COST, \$
4.15x10 <sup>6</sup>		2.60		10.79x10 <sup>6</sup>

STEP 4: DETERMINE TOTAL DIRECT COST

B	+	I	=	(D) TOTAL DIRECT COST \$
10.79x10 <sup>6</sup>		6.02x10 <sup>6</sup>		16.81x10 <sup>6</sup>

STEP 5: DETERMINE TOTAL INVESTMENT COST

D	X	INDIRECT COST FACTOR	=	TOTAL INVESTMENT COST, \$
16.81x10 <sup>6</sup>		1.325		22.27x10 <sup>6</sup>

Efficient capital budgeting requires, among other items, careful examination and evaluation of alternative demands for capital. To effectively evaluate alternatives, some equivalent basis of comparison that summarizes the significant differences among alternatives is necessary. Most evaluation techniques produce a single index or measure. Often this measure is used, along with other decision criteria, to select the most efficient investment.

Because circumstances (size of investment, risk, etc.) and objectives (cost reduction, income generation, replacement, etc.) of investment decisions vary, and because particular evaluation techniques are inherently different, several common evaluation

techniques are discussed below: 1) payback period, 2) accounting rate of return, and 3) life-cycle-costing techniques, which include internal rate of return and net present value. It is important to determine which economic analysis tool is most commonly accepted for investment decisions in each particular company.

For each method, the benefits and costs resulting from an investment must be estimated. Other considerations affecting the economic feasibility of investments include the applicability of energy and investment tax credits, the cost of borrowed capital, and federal and state taxes. Because of escalating energy prices, many companies may prefer the internal rate of return or the

TABLE 4.12. Fuel Cost Calculations for Textile Finishing Mill Example

FUEL COST WITH COGENERATION:

FUEL USE, F (10 <sup>9</sup> BTU/HR)	X	LOAD FACTOR (HRS/YR)	X	FUEL PRICE (\$/10 <sup>9</sup> BTU)	=	ANNUAL FUEL COST (\$/YR)
228		6240		1.72		\$2,447,078
TOTAL A						\$2,447,078

FUEL COST WITHOUT COGENERATION:

FUEL TYPE	FUEL USE (UNITS/YR)	X	FUEL PRICE (\$/UNIT)	=	ANNUAL FUEL COST (\$/YR)
COAL	59,800 tons/yr		\$45/ton		\$2,691,000
TOTAL B					\$2,691,000

INCREMENTAL FUEL COST = A-B = (OR SAVINGS)	\$(243,922)
---	-------------

net present value. These techniques account for costs and revenues over the entire life of the equipment.

4.5.1 Payback Period

The payback period (P) is a simplistic investment evaluation method. It is equal to the ratio of the initial investment (I) over the annual cash inflow (CF). If the cash inflows are equal for each year, it is represented as:

$$P = \frac{I}{CF}$$

If the cash inflows vary from year to year, the payback period is equal to the number of years (t) it takes for the cash inflows to equal the initial investment:

$$I = \sum_{t=0}^n CF_t$$

where

n = last year in which cash flow is expected.

Payback is a very limited investment evaluation tool. It ignores the time value of money and fails to consider project earnings after the initial investment has been recovered. Despite these disadvantages, payback period is a quick method to gauge the early recovery of funds invested.

4.5.2 Accounting Rate of Return

The accounting rate of return (ARR) is another simplistic investment evaluation method. It is the ratio of average annual after-tax profit (ATP) over the investment:

$$ARR = \frac{(ATP)}{I}$$

TABLE 4.13. Electricity Cost/Revenue Calculations for Textile Finishing Mill Example

I. BASE CASE ELECTRICITY COST

(A) ANNUAL USE (kWh/YR)	X	ELECTRIC RATE (\$/kWh)	=	(B) ANNUAL PURCHASED ELECTRICITY COST (\$/YR)
38.7x10 <sup>6</sup>		0.045		1.74x10 <sup>6</sup>

ELECTRICITY COGENERATED (MW)	X	LOAD FACTOR (HOURS/YR)	X	1000 kW MW	=	(C) ANNUAL ELECTRICITY COGENERATED (kWh/YR)
6.2		6240		1000		38.7x10 <sup>6</sup>

II. COGENERATING INTO PLANT LOAD

C	-	A	=	(D) ELECTRICITY DEFICIT OR EXCESS (kWh/YR)
38.7x10 <sup>6</sup>		38.7x10 <sup>6</sup>		0

CASE 1: IF D IS NEGATIVE (DEFICIT), PURCHASE EXCESS POWER:

D	X	ELECTRIC RATE (\$/kWh)	=	(E) ANNUAL PURCHASED ELECTRICITY COST (\$/YR)

CASE 2: IF D IS POSITIVE (EXCESS), SELL EXCESS POWER:

D	X	AVOIDED COST (\$/kWh)	=	(E) ANNUAL ELECTRICITY REVENUE (\$/YR)

INCREMENTAL SAVINGS

B	+	E	=	INCREMENTAL SAVINGS (\$/YR)
1.74x10 <sup>6</sup>		0		1.74x10 <sup>6</sup>

III. SIMULTANEOUS SALE AND PURCHASE

C	X	AVOIDED COST- ELECTRIC RATE (\$/kWh)	=	INCREMENTAL SAVINGS (\$/YR)
38.7x10 <sup>6</sup>		0.005		193,500

This method requires an estimate of net annual profit. For cogeneration systems, the net annual profit is the revenues from surplus electricity sales, plus any energy cost savings that might occur with fuel switching (e.g., from oil to coal), plus energy and investment tax credits (if applicable), minus fixed and variable costs consisting of the following:

- property taxes and insurance
- labor and maintenance
- federal taxes.

If all or part of the cost of the equipment is financed, then the cost of borrowed capital is also included as an expense item.

In practice, two methods are used to determine the investment. One method uses the

TABLE 4.14. Cogeneration Project Cash Flows for Textile Mill Example  
(cash flows in thousands of dollars)

YEAR	CAPITAL COSTS	DEPRECIATION <sup>(a)</sup>	FUEL COSTS <sup>(b)</sup>	ELECTRICITY COST OR REVENUE <sup>(c)</sup>	O&M COSTS <sup>(d)</sup>	TAXABLE INCOME	TAXES <sup>(e)</sup>	TAX CREDITS <sup>(f)</sup>	AFTER-TAX CASH FLOW
1983	-22,270	-	-	-	-	-22,270	-	-	-22,270
1984	-	-3,340.5	243.9	1,740	-302	-1,658.6	-	-	1,681.9
1985	-	-4,899.5	250.0	1,757	-315	-3,197.5	-	-	1,702.0
1986	-	-4,676.7	256.3	1,775	-327	-2,972.4	-	-	1,704.3
1987	-	-4,676.7	262.7	1,793	-340	-2,961.0	-	-	1,715.7
1988	-	-4,676.7	269.2	1,811	-354	-2,950.5	-	-	1,726.2
1989	-	-	276.0	1,829	-368	1,737.0	-799.0	799.0	1,737.0
1990	-	-	282.9	1,847	-383	1,746.9	-803.6	803.6	1,746.9
1991	-	-	289.9	1,866	-398	1,757.9	-808.6	624.4	1,573.7
1992	-	-	297.2	1,884	-414	1,767.2	-812.9	-	954.3
1993	-	-	304.6	1,903	-430	1,777.6	-817.7	-	959.9
1994	-	-	312.2	1,922	-448	1,786.2	-821.7	-	964.5
1995	-	-	320.0	1,941	-466	1,795.0	-825.7	-	969.3
1996	-	-	328.0	1,961	-484	1,805.0	-830.3	-	974.7
1997	-	-	336.2	1,980	-504	1,812.2	-833.6	-	978.6
1998	-	-	344.7	2,000	-524	1,820.7	-837.5	-	983.2
1999	-	-	353.3	2,020	-545	1,828.3	-841.0	-	987.3
2000	-	-	362.1	2,040	-566	1,836.1	-844.6	-	991.5
2001	-	-	371.2	2,061	-589	1,843.2	-847.9	-	995.3
2002	-	-	380.4	2,081	-613	1,848.4	-850.3	-	998.1
2003	-	-	389.9	2,102	-637	1,854.9	-853.3	-	1,001.6

- (a) Noncash expense used to calculate taxable income.  
 (b) Assumed to escalate at 2.5% per year.  
 (c) Assumed to escalate at 1% per year.

- (d) Assumed to escalate at 4% per year.  
 (e) 46% of taxable income.  
 (f) 10% of capital investment.

average net investment, which is the initial investment divided by the depreciable life of the equipment. The other method uses the initial investment. These methods would provide very different rates of return. The major disadvantages of the accounting rate of return are that it is based on profit rather than cash flows and that it ignores the time value of money.

#### 4.5.3 Life-Cycle Costing Techniques

Life-cycle costing techniques consider total relevant costs and revenues over the life of a system. These techniques include internal rate of return and net present value. Life-cycle costing is a useful approach for comparing cogeneration configurations and/or financing alternatives.

The major steps in performing life-cycle cost analysis are as follows:

1. Identify relevant cost items for each alternative.
2. Determine magnitude and timing of cash flows.
3. Calculate life-cycle costs.
4. Compare costs of alternatives.

Life-cycle cost analysis accounts for costs and revenues over the life of the system, rather than first costs only. For a cogeneration system, this requires examining the following kinds of costs: 1) system acquisition costs, including purchase prices, delivery costs, and installation costs, 2) system O&M costs, 3) repair and replacement costs, 4) insurance, 5) taxes, and 6) salvage value.

A life-cycle cost comparison of alternatives may be based on total costs for each system or on incremental costs among alternatives. Since only cost differences are critical in choosing among alternatives, the incremental-cost approach is often used. Cost items that are identical for the alternatives can be omitted without changing the outcome of the analysis.

#### Internal Rate of Return

The internal rate of return (IRR) is the discount rate for which a cogeneration investment's present value of the after-tax cash flows is zero. In other words, it equates the present value of the expected cash outflows with the present value of the expected inflows. It is also called discounted-cash-flow (DCF) rate of return.

$$\sum_{t=0}^n \left[ \frac{CF_t}{(1+r)^t} \right] = 0$$

where

$CF_t$  = after-tax cash flow for year  $t$   
(from Table 4.10)

$n$  = last year in which cash flow is expected

$r$  = IRR

$t$  = year of cash flow.

A company should invest if the IRR is greater than the opportunity cost of capital.

There are three things to be aware of:

1. Short-term interest rates may differ from long-term rates.
2. If there is more than one change in the sign of the cash flows, there may be multiple IRRs or no real IRR.
3. The technique must be used on each additional unit of investment.

When choosing between mutually exclusive investment opportunities, the IRR analysis will not ensure maximum overall return to the firm if any one of the following conditions is true:

- the initial investments are different
- the investments have different depreciation lives
- the cash-flow streams are significantly different.

#### Net Present Value

The net present value (NPV) is a discounted-cash-flow method much like the IRR.

$$NPV = \sum_{t=0}^n \frac{CF_t}{(1+r)^t}$$

where

$CF_t$  = after-tax cash flow for year  $t$   
(from Table 4.10)

$r$  = required rate of return

$t$  = year of cash flow

$n$  = last year in which cash flow is expected.

Generally, the net present value is computed for the life of the cogeneration system. Alternatively, the period of analysis may be equal to or much shorter than the cogeneration system life. A reason for limiting the period of analysis is to decrease the uncertainty in forecasts of energy availability and economic conditions. If a very low discount rate were used, the results would be quite sensitive to the period of analysis; if a relatively high discount rate were used, the results would be much less sensitive.

The more positive the net present value of an alternative, the more attractive the option, since positive values represent savings and negative values represent costs. If the analysis is performed on an incremental-cost basis, a positive net present value indicates that cogeneration is less costly than purchasing power from a utility.

Table 4.15 provides a format for computing discounted cash flows for an investment and for calculating the four investment-analysis measures discussed above. The after-tax cash flows from Table 4.10 are multiplied by present worth factors to obtain the discounted cash flows. The present worth factors may be obtained from an accounting or finance text or calculated from the formula given in Appendix E.

The discount rate is referred to in many ways: cost of capital, minimum desired rate of return, cutoff rate, target rate, hurdle rate, and financial standard. Regardless of what it is called, the discount rate is the rate of return on the project that theoretically will leave the market price of the firm's stock unchanged. However, there is little agreement on how to measure it.<sup>(8)</sup> The energy manager must be guided by his firm's accounting practice.

#### 4.6 SENSITIVITY ANALYSIS

The outcome of the cogeneration investment analysis can be quite sensitive to the data estimates and assumptions made in the analysis. In particular, a great deal of uncertainty is associated with estimating future cost escalation.

Sensitivity analysis (parametric analysis) provides a systematic means of determining the importance of each independent factor on the end result. In sensitivity analysis, one parameter is varied incrementally over its expected range of values while all other





project risk and also serves as a guide to where additional efforts in refining estimates (reducing uncertainty) would be most valuable.

#### 4.7 IMPACT OF TAX PARAMETERS

Recent energy legislation affects the implementation and economic viability of industrial cogeneration systems. It is extremely important that a potential cogenerator become familiar with this legislation so that maximum advantage can be taken of available benefits. Because the regulations have been changing and are subject to future change, it is necessary to remain current on this topic. The following are recent tax acts that either directly or indirectly impact implementation of cogeneration systems:

- Energy Tax Act (ETA) of 1978
- Crude Oil Windfall Profit Tax Act (COWPTA) of 1980
- Economic Recovery Tax Act (ERTA) of 1981.

##### 4.7.1 ETA

The ETA provides for changes in the business investment credit to encourage conservation of, or conversion from, oil and gas. The 10% energy investment tax credit for investments in designated energy property is in addition to the regular 10% investment tax credit. Although energy credits generally apply to costs incurred for the period of October 1, 1978, through December 31, 1982, it is important to discuss the ETA to understand past available benefits and what might be possible if an extension or revision is made.

To qualify for the energy investment credit, the property must have been new (not used) and first placed in service after September 30, 1978. The energy credit (but not the regular investment tax credit) is available for structural components of buildings that otherwise qualify as energy property. Cogeneration equipment and facility investments are not specifically addressed in the ETA. However, the ETA provides energy investment tax credits for two classes of property, which include several of the components, both equipment and structural, which may be used in cogeneration systems. These energy-property classifications are alternative-energy property and specially defined energy property. Alternative-energy property includes boilers, burners, fuel-handling equipment, and associated pollution-control equipment for systems that do not use oil or natural gas as a primary fuel. Also included as alternative-energy

equipment are modifications to existing equipment that use oil or natural gas as a fuel, so that such equipment will use a substance other than oil or natural gas, or an oil mixture where oil will not constitute more than 75% of the fuel. Specially defined energy property includes recuperators, regenerators, heat wheels, heat exchangers, waste-heat boilers, heat pipes, automatic energy-control systems, tubulators, preheaters, combustible-gas-recovery systems, economizers, and any other property of a kind specified by the Secretary of the Treasury by regulations, the principal purpose of which is reducing the amount of energy consumed in any existing industrial or commercial process and which is installed in connection with an existing industrial or commercial facility.

##### 4.7.2 COWPTA

The COWPTA establishes new tax incentives for energy efficiency and extends or modifies certain provisions included in the ETA. The COWPTA provides a 10%, nonrefundable energy credit for qualified investments in cogeneration equipment. The equipment must not use oil or natural gas or their by-products as fuel for any purpose other than startup, flame control, or backup. Further, during any taxable year, not more than 10% (determined on a Btu-input basis) of the fuel can be oil or natural gas or their products.

The energy tax credit allowed by COWPTA was applicable to investments made between January 1, 1980, and December 31, 1982. However, the 10% energy tax credit may be extended to December 31, 1990, if both of the following criteria are met or apply to a cogeneration project with a normal construction period of two years or more:

- Before January 1, 1983, the taxpayer has completed all engineering studies in connection with the commencement of project construction.
- Before January 1, 1986, the taxpayer has entered into binding contracts for the acquisition, construction, reconstruction, or erection of equipment specially designed for the project, and the total cost to the taxpayer of that equipment is at least 50% of the reasonably estimated cost of all such equipment that is to be placed in service as a part of the project upon its completion.

To qualify for the 10% energy tax credit, cogeneration equipment must not be public utility property. Public utility property is that used predominantly in the trade or

business of furnishing or selling of electric energy and steam through a local distribution system or transportation of steam by pipeline, if the rates are fixed by a public body such as a public utility commission. Sale of electricity by cogenerators to utilities at rates based on avoided costs pursuant to PURPA does not disqualify property for the 10% energy tax credit.

#### 4.7.3 ERTA

Although not directed specifically at cogeneration, the ERTA provides significant tax incentives for new business investment in general. This tax act provides for an Accelerated Cost Recovery System (ACRS), which determines the depreciation life and the depreciation method for investments in equipment. The depreciation life is generally 5 years in accordance with ERTA. Depreciation methods in the ACRS include 150% declining balance (DB) changing to straight line (150% DB/SL), 175% DB changing to sum-of-the-years'-digit (SYD) (175% DB/SYD), and 200% DB changing to SYD (200% DB/SYD).

#### REFERENCES

1. Peters, M. S. and K. D. Timmerhaus. 1968. Plant Design and Economics for Chemical Engineers. McGraw-Hill Book Company, New York, New York.
2. Gerlaugh, H. E., et al. 1979. Cogeneration Technology Alternatives Study (CTAS) General Electric Company Final Report. Volume I. N80-24797. National Technical Information Service, Springfield, Virginia
3. Office of Technology Assessment. 1983. Industrial and Commercial Cogeneration. Congress of the United States, Washington, D.C.
4. Energy Information Administration. 1983. Monthly Energy Review. U.S. Department of Energy. Washington, D.C.
5. Energy Information Administration. 1982. 1982 Annual Energy Outlook. DOE/EIA-0383, U.S. Department of Energy, Washington, D.C.
6. Chemical Engineering. Vol. 90 No. 12. June 13, 1983.
7. Lowenstern, H., Editor-in-Chief. 1983. Monthly Labor Review. U.S. Department of Labor, Bureau of Labor Statistics, Washington, D.C.
8. Horngren, C. T. 1977. Cost Accounting - A Managerial Emphasis. Fourth Edition. Prentice-Hall, Inc. Englewood Cliffs, New Jersey.

## 5.0 FINANCIAL STRATEGIES

Recent tax law changes have increased the importance of investigating alternative financing options for cogeneration projects. Because the ability to qualify for or effectively use tax incentives varies among potential cogeneration system owners, arrangements other than ordinary sales may sometimes improve the economics. Alternative arrangements can allow tax incentives to be effectively used by one party in the transaction, who can then make the cogeneration system available to the system user at a lower price.

The two essential parties to any financial transaction are the buyer and the seller. However, the transactions might also include "third parties" -- other institutions that intervene in transactions between the buyer and seller, as opposed to working through either one of them. In a rough sense, a third party is somewhat like a wholesaler, who buys from the seller and then sells to the buyer. Figure 5.1 shows the three parties and the types of financial aid that might be involved in an alternative-financing arrangement.<sup>(1)</sup>

This section describes alternative methods of financing cogeneration projects, including ordinary sales, sales with borrowed financing, four types of leases, and joint ventures. In many situations, alternative-financing arrangements can significantly enhance the economics of cogeneration projects by providing a way to efficiently allocate elements of risk, return on investment, required capital investment, and tax benefits.

### 5.1 ORDINARY SALE

In an ordinary sale, the user would simply receive the cogeneration equipment from the manufacturer in exchange for the purchase price (Figure 5.2). An industrial plant will usually want to own and operate its cogeneration equipment. However, several California utilities have built and now own and operate cogeneration facilities at industrial plants. The utilities sell the heat or steam to the plants and add the electricity to their grids. The plants have the benefit of guaranteed process heat supplies without the costs of purchasing and operating the cogeneration system. For example, the Garden State Paper Company in Pomona, California, gets all of its process steam and electricity from a 15-MWe cogeneration facility owned by Southern California Edison Company.<sup>(2)</sup>

Another possible arrangement is for a third party to own and operate the cogeneration facility. The third party, an independent cogeneration company, will receive the tax benefits in return for designing, building, and operating the facility. For example, Applied Energy, Inc., a subsidiary of San Diego Gas and Electric Company, owns and operates a 0.8-MWe cogeneration facility at Rohr Industries' plant in Chula Vista, California. Rohr buys the steam from the facility and San Diego Gas and Electric Company buys the power.<sup>(2)</sup>

### 5.2 SALE WITH BORROWED FINANCING

A sale with borrowed financing would involve a bank as a third party (Figure 5.3). The

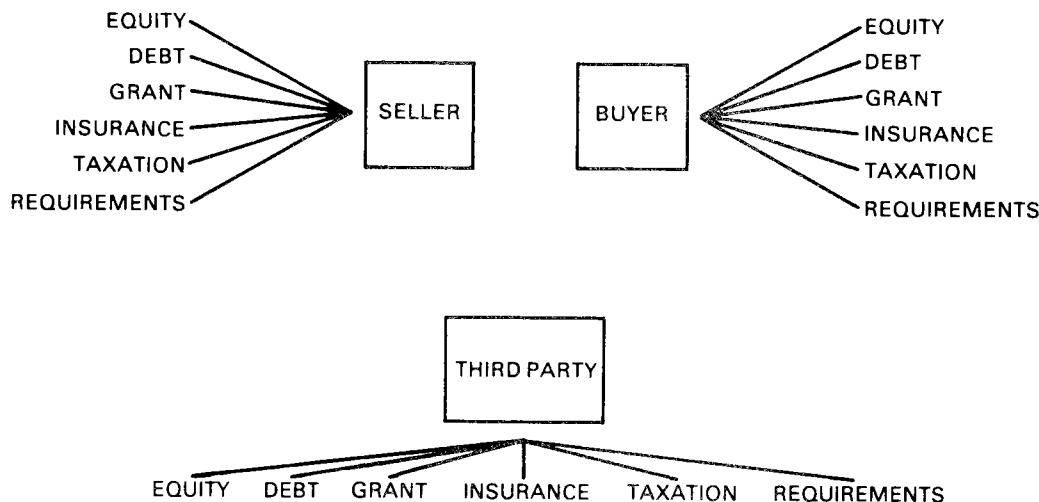

Figure 5.1. Parties and Types of Financial Aid in an Alternative-Financing Arrangement<sup>(1)</sup>

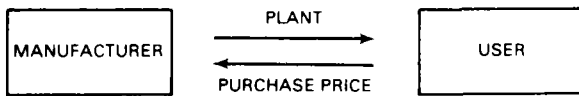

FIGURE 5.2. Ordinary Sale<sup>(1)</sup>

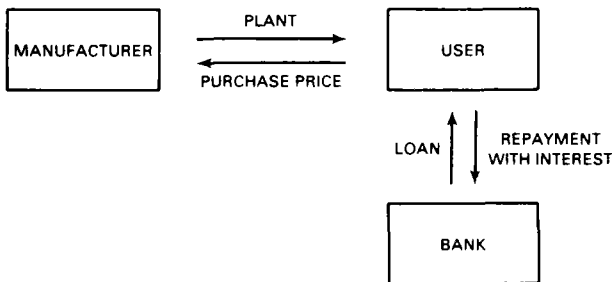

FIGURE 5.3. Sale with Borrowed Financing<sup>(1)</sup>

user (industrial plant or utility) would take out a bank loan to help finance the purchase of the cogeneration equipment from the manufacturer. The user would repay the loan with interest.

### 5.3 LEASE

A lease is a rental agreement in which the equipment user (lessee) promises to make a series of payments to the equipment owner (lessor). At the end of the lease term, the lessee has the option to purchase the equipment or take out a new lease. The lessor obtains the tax benefits of ownership during the lease term and can pass these savings on to the lessee through lower lease payments.

Leasing provides various advantages to both the lessor and the lessee. For the lessor, advantages include availability of accelerated depreciation to reduce tax liability, applicable investment and energy tax credits, and the residual value of the equipment. For the lessee, advantages include 100% financing (no capital requirement); the possibility of lower payments than a bank loan would require, assuming that the value of tax benefits is passed on; and because of off-balance-sheet financing, no direct decrease of the lessee's net worth.

Leasing offers particular tax advantages in cogeneration financing. In a typical arrangement, a corporation investor would buy the cogeneration equipment and lease it to a utility. The utility could realize significant savings if the tax credits available to the corporation (and not

available to the utility) were passed on to it through lower lease payments.

In the following subsections, several types of leases are described: ordinary lease, third-party lease, leveraged lease, and sale leaseback.

#### 5.3.1 Ordinary Lease

In what is called an "ordinary lease" only two parties are involved, and the user would agree to make regular lease payments to the equipment manufacturer in return for use of the equipment (Figure 5.4). This type of leasing arrangement operating directly between the manufacturer and user is unlikely. Usually, a third party would be involved in the lease transaction.

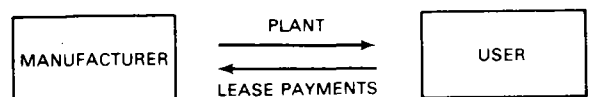

FIGURE 5.4. Ordinary Lease<sup>(1)</sup>

#### 5.3.2 Third-Party Lease

A third-party lease would involve the manufacturer, the user, and the owner, who acts as the third party (Figure 5.5). In this arrangement, the owner, most likely a corporate investor, would purchase the equipment from the manufacturer and lease it to the user in exchange for regular payments. The owner (lessor) would receive tax benefits, which could be passed on to the user (lessee) in the form of reduced lease payments.

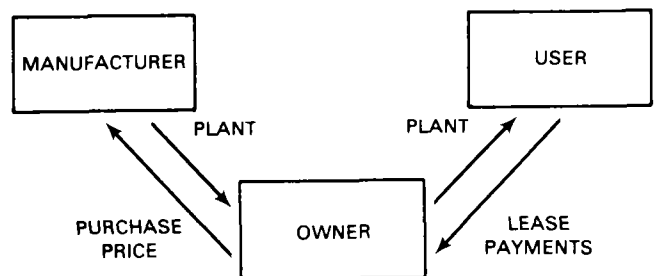

FIGURE 5.5. Third-Party Lease<sup>(1)</sup>

#### 5.3.3 Leveraged Lease

In leveraged leasing, part of the cost of the leased equipment is financed through a loan secured by the equipment and the lease payments. The owner (lessor) issues debt and equity claims against the equipment and the lease payments (Figure 5.6). The owner (lessor) is the intermediary among all the parties involved. The owner raises most of

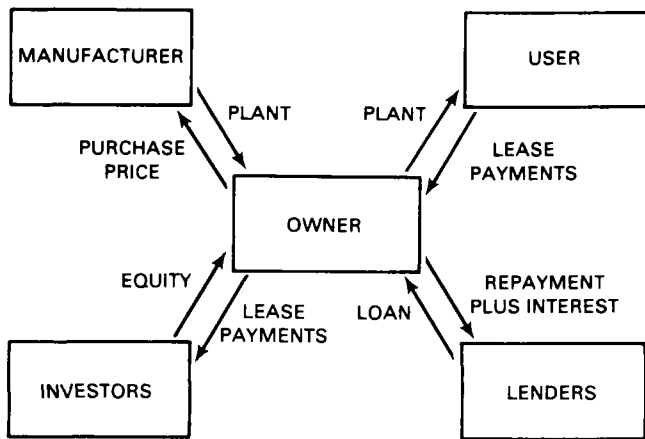

FIGURE 5.6. Leveraged Lease<sup>(1)</sup>

the capital needed to buy the equipment by taking out a loan. The remaining capital is contributed by equity investors. After purchasing the equipment, the owner makes a lease agreement with the user and receives regular lease payments. The lenders have a security interest in the leasing contract. The lease payments received by owner (lessor) are used to repay the lenders. The amount left over repaying the loan and interest is distributed to the equity investors. Tax benefits received by the lessor are also passed on to the investors.<sup>(1)</sup>

Leveraged leasing offers tax advantages to the owner (lessor). The owner gets the tax shields created by the interest payments on the loan as well as by accelerated depreciation. Also, although the owner has only a modest equity investment in the equipment, the total equipment cost can be depreciated.

#### 5.3.4 The Sale-Leaseback Method

Under the Economic Recovery Tax Act of 1981 (ERTA), companies that previously were unable to take advantage of investment tax credits may be allowed these benefits through sale-leaseback financing (sometimes called "safe-harbor leases"). In the sale-leaseback method, a company that cannot benefit from tax credits sells equipment to a company that can benefit from such credits. The new equipment owner then leases the equipment back to the original owner under contract. The lessor (equipment owner) and the lessee (equipment user) are then able to share in the tax benefits allowed to the lessor.

Because the Treasury Department interpretation of the law is uncertain, a company's ability to make use of sale-leaseback arrangements will ultimately depend on final guidelines to be issued by the IRS. While these guidelines are still undetermined, interim Treasury Department guidelines are found in the IRS "safe-harbor" provisions.

There are three basic requirements: (1) the lessor must be a "regular corporation;" (2) the lessor's minimum investment in the leased equipment must never be less than 10% of the equipment's cost (25% for energy equipment); and (3) the term of the lease, including extensions, must not exceed 90% of the equipment's useful life for depreciation purposes or 150% of the present class life of the equipment. An additional requirement is that the lessor must buy the equipment within three months of the lessee's original purchase. If the final IRS rules do not impose further major restrictions on the use of sale-leaseback arrangements, manufacturers and utilities will have been provided with a major incentive to enter the cogeneration market.<sup>(1)</sup>

A sale-leaseback arrangement for cogeneration financing would involve two basic steps (Figure 5.7). In the first step, an industrial plant or a utility would buy and assemble the necessary equipment. A corporation rich in capital but needing tax deductions would buy the equipment from either the industrial plant or the utility. The seller would receive a fraction of the entire equipment cost (not less than 25%) in the form of a down payment. In the second step, the corporation would lease the equipment back to the seller (industrial plant or utility). The transaction would be arranged so that the remaining purchase payments

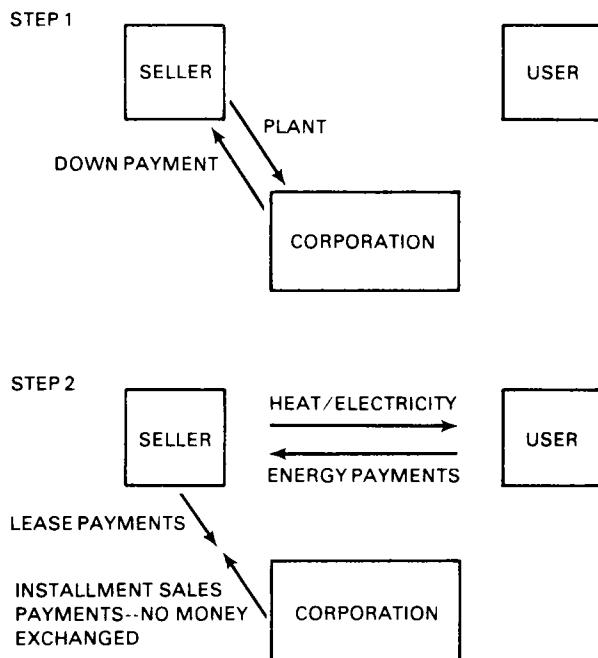

FIGURE 5.7. Sale-Leaseback ("Safe-Harbor" Lease)<sup>(1)</sup>

(step 1) are exactly offset by the lease payments (step 2). Thus, no more cash would be exchanged between the two parties. Following the leaseback transaction, the industrial plant or the utility would be able to use the equipment. Meanwhile, the corporation would be able to take advantage of the tax benefits. When the term of the lease was up, the industrial plant or utility could choose to repurchase the equipment for as little as one dollar.<sup>(1)</sup>

This type of package provides advantages to both the seller and the corporation. The net cost of the equipment to the seller has been reduced by the amount that the corporation paid the seller for the tax benefit. The corporation has received a tax write-off because the lease payments are equal to the debt payments, and because it may ultimately sell the depreciated equipment back to the original seller for less than the fair market value, realizing no capital gain. Furthermore, the corporation has invested a relatively small amount of money at risk, and it eventually recovers this sum. The original seller has accepted most of the risk in the investment.

An example of a sale-leaseback transaction is under way at Diamond/Sunsweet, a cooperative walnut-processing plant in Stockton, California. Diamond/Sunsweet plans to build a 4.5-MWe cogeneration facility, sell it to a group of investment companies, and then lease it back. The benefits to Diamond/Sunsweet are in lower energy costs, while the benefits to the investment companies are in tax credits and depreciation.<sup>(2)</sup>

#### 5.4 JOINT-VENTURE FINANCING

Joint-venture financing is an option that offers the benefits of combining the skills and experience of different organizations through cooperative agreements. The range of possible partners in joint-venture financing is virtually limitless. However, some likely participants include municipal or

investor-owned utilities, leasing corporations, banks, equity firms, individual investors, engineering firms, energy management companies, equipment manufacturers, equipment vendors, local government entities, nonprofit organizations, and private nonprofit foundations. Financing mechanisms that may not be possible or conceivable using traditional arrangements may be developed effectively when the resources and expertise of two or more entities are used. The various parties involved may facilitate creative combinations of financing methods. These arrangements may include techniques such as issuing bonds, raising capital from private investors, lease financing, and direct purchase. Because of the originality of many joint-venture agreements, it is particularly crucial that all parties involved understand and accept their responsibilities.<sup>(1)</sup>

A joint venture between an industrial plant and a utility has been successful in Pampa, Texas. There, the Celanese Chemical Company and the Southwestern Public Service Company jointly own and operate a 30-MWe cogeneration facility. Celanese owns and operates a coal-fired boiler that produces steam for the utility-owned turbine generator. Celanese and the utility share the electricity.<sup>(2)</sup>

#### REFERENCES

1. Williams, T. A., et al. 1983. Solar Thermal Financing Guidebook. PNL-4754, Pacific Northwest Laboratory, Richland, Washington.
2. California Governor's Office of Planning and Research. 1980. Cogeneration - Energy for the 80s and Beyond. Sacramento, California.

## 6.0 ENVIRONMENTAL ISSUES

This chapter discusses the environmental aspects of installing a cogeneration system. These aspects include environmental regulations, types of pollutants, environmental impacts of the various prime movers and fuels, and current emission-control technology.

### 6.1 FEDERAL REGULATIONS

The most important step in determining the required pollution-control equipment and regulatory steps to gain approval for a new cogeneration plant is to contact the Environmental Protection Agency (EPA) office responsible for the area in which the cogeneration plant is to be located. The regional EPA offices are listed in Appendix H.

The most likely regulations that will apply are the 1980 Prevention of Significant Deterioration (PSD) regulations found in the Code of Federal Regulations (CFR) under Title 40, CFR 52.21. Advance contact with the EPA's PSD reviewing authorities is the most useful way to determine whether PSD regulations apply and whether a PSD application will be required. The federal regulations do not describe the requirements that State Implementation Plans (SIP) may require. With these plans, states may revise portions of the federal PSD regulations to conform to their existing or proposed methods of implementation. Generally, SIP provisions that differ with federal PSD requirements will be more restrictive. Large steam generators with heat inputs greater than 250 MMBtu/hour are also regulated by New Source Performance Standards (NSPS) regulations. The EPA has prepared an extensive publication entitled Prevention of Significant Deterioration, Workshop Manual.<sup>(1)</sup> Copies of this manual are available from the EPA.

Figure 6.1 outlines the required steps in the regulatory process to gain approval for a new cogeneration system. Table 6.1 gives the emission levels of the controlled pollutants that are considered significant under PSD regulations. Additional information on actual PSD determinations is available for public inspection at

Environmental Protection Agency  
Region II Office, Permits and  
Administration Branch  
Office of Policy and Management  
26 Federal Plaza, Room 432  
New York, New York 10278  
(212) 264-4711

### 6.2 TYPES OF POLLUTANTS

The primary environmental concern associated with a cogeneration facility is the air pollution caused by fuel combustion.

Water-quality and solid-waste impacts also result from the combustion system, but to a lesser extent than air pollution. The primary air pollutants of concern are particulates, sulfur dioxide ( $SO_2$ ), and nitrogen oxides ( $NO_x$ ). Other air pollutants of secondary concern are carbon monoxide (CO) and hydrocarbons (HC).

Particulates will be emitted into the environment by the combustion of all coals, and, to a lesser degree, by fuel oils. One particulate, flyash, is composed mainly of silica and some metal oxides. In coal combustion, the stack gases will also contain unburned carbon particles.

Most coals and many fuel oils contain sulfur. Their combustion will result in the formation of sulfur oxides ( $SO_x$ ), predominantly  $SO_2$  and, to a lesser extent, sulfur trioxide ( $SO_3$ ). The level of  $SO_x$  generated is directly proportional to the fuel's sulfur content.

The reactions responsible for creating  $NO_x$  are much more complex than those of  $SO_x$ . The amount of  $NO_x$  depends only to a small degree on the fuel's composition. The major source of nitrogen is the combustion air. The predominant  $NO_x$  in the stack gas is  $NO$ ; in most combustion processes there is not enough residence time to fully oxidize  $NO$  to  $NO_2$ .

Although cogeneration facilities can generate water-carried pollutants, federal water pollution regulations applicable to cogeneration are minimal. There are federal water pollution standards that apply to facilities generating electricity for distribution and sale. Excepted from these standards are facilities with less than 25-MW rated net generating capacity or any units that are part of an electric utility system with a total net generation capacity less than 150 MW.<sup>(2)</sup>

The solid wastes that can be generated by cogeneration facilities include flyash, bottom ash, slag, and flue-gas-emission-control water. The management of these wastes will generally be controlled by state and local regulations rather than by federal regulations. The solid or liquid wastes that may meet the criteria of hazardous

STEP 1 COLLECT SIZE, LOCATION  
AND FUEL INFORMATION  
AND CONTACT THE EPA

STEP 2 VERIFY STEPS REQUIRED  
AND OBTAIN EPA  
RECOMMENDATIONS  
ON BEST AVAILABLE  
CONTROL TECHNOLOGY

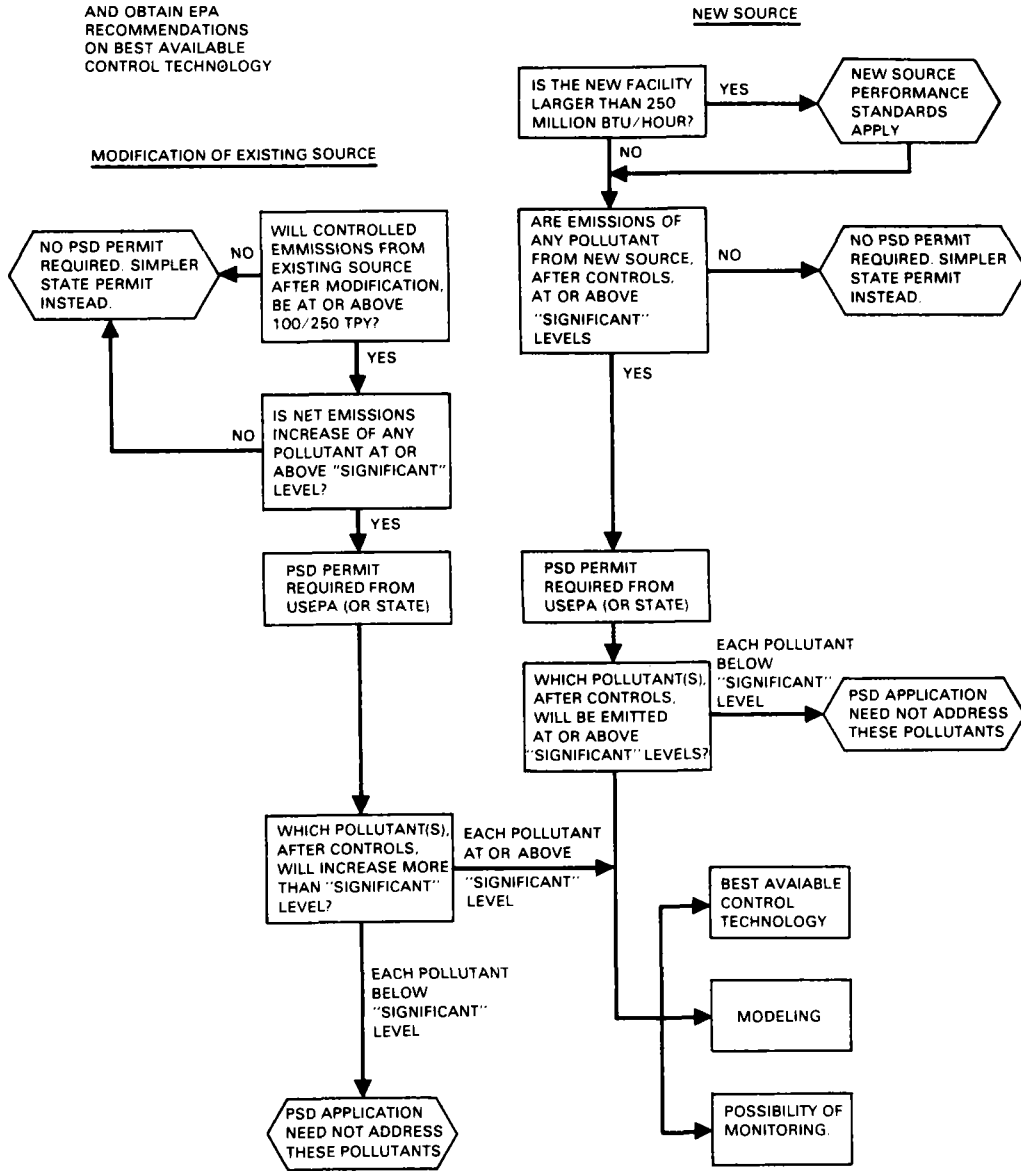

FIGURE 6.1. Outline of Preconstruction Review of Major Pollution-Control Regulations(2)



**TABLE 6.1. Emission Levels Considered Significant Under PSD Regulations**<sup>(a)(2)</sup>

<u>Pollutant</u>	<u>Emissions Rate (tons/year)</u>
Carbon monoxide	100
Nitrogen oxides	40
Sulfur dioxide	40
Particulate matter	25
Ozone	40 <sup>(b)</sup>
Lead	0.6
Asbestos	0.007
Beryllium	0.0004
Mercury	0.1
Vinyl chloride	1
Fluorides	3
Sulfuric acid mist	7
Hydrogen sulfide	10
Total reduced sulfur <sup>(c)</sup>	10
Reduced sulfur compounds <sup>(c)</sup>	10

(a) In spite of the above values, any major source or modification located within 10 km of a Class I area that causes an increase of at least 1  $\mu\text{g}/\text{m}^3$  in the ambient air concentration (over the Class I area) for a regulated pollutant (i.e., a pollutant for which an emission or air quality standard has been established) is regarded as emitting significant amounts of that pollutant.

(b) Volatile organic compounds.

(c) Including hydrogen sulfide.

wastes under the Resource Conservation and Recovery Act are those containing corrosion inhibitors used to prevent boiler-tube fouling in steam-turbine systems.<sup>(2)</sup>

### 6.3 COMBUSTION SYSTEMS AND FUELS

The environmental impacts resulting from cogeneration facilities depend on the type of prime mover and fuel used, as discussed below.

#### 6.3.1 Steam Turbines

Steam turbines can be major sources of air pollution and can also produce significant amounts of water pollutants and solid waste, depending upon the fuel used. Air pollutants produced during combustion in fossil-fuel-fired boilers include particulates,  $\text{SO}_2$ , and  $\text{NO}_x$ . Most of these pollutants are caused by firing bituminous coal. Fuel-oil firing is a factor in  $\text{SO}_x$  and  $\text{NO}_x$  emissions, while wood-fired boilers emit particulates and  $\text{NO}_x$ .<sup>(2)</sup>

#### 6.3.2 Gas Turbines

Gas turbines produce some air pollutants, but generate minimal water pollutants and solid waste. The air pollutants of con-

cern are  $\text{NO}_x$  and  $\text{SO}_2$ . The emissions of particulates, HC, and CO are less significant.<sup>(2)</sup>

#### 6.3.3 Diesel Engines

Diesel engines are sources of several air pollutants:  $\text{NO}_x$ , CO, particulates, HC, and  $\text{SO}_2$ . Large-bore engines, which would be used in cogeneration systems, account for the majority of  $\text{NO}_x$  emissions from diesel engines, but relatively small amounts of HC and CO emissions. Eighty percent of the HC are comprised of methane, a nonreactive pollutant. CO emissions, although significant for carbureted or naturally aspirated gas engines, are much lower for diesel engines. Particulate emissions from diesel engines are believed to be very small, averaging about 33.5 lbs/1000 gallons of fuel consumed.<sup>(2)</sup>

$\text{SO}_x$  emissions from diesel engines depend upon the sulfur content of the fuel and the firing rate. The use of low-sulfur fuels is currently the only viable method of  $\text{SO}_2$  control, since exhaust-gas scrubbing is not economically feasible. Because of the lower O&M costs of burning low-sulfur fuel, industries are expected to continue this emission control approach. Therefore,  $\text{SO}_2$  emissions from these sources are expected to be minor. Other environmental impacts (water pollution or solid waste) are nonexistent from diesels using low-sulfur fuel.<sup>(2)</sup>

### 6.4 EMISSION-CONTROL DEVICES

Various emission-control devices to reduce the pollution loads of cogeneration facilities to acceptable levels are available from many vendors. Although the details of these techniques are beyond the scope of this handbook, the major ones are discussed briefly below.

#### 6.4.1 Particulate Emissions Control

Four types of emission-control devices are used for particulates: electrostatic precipitation, fabric filters, wet scrubbers, and multitube cyclones.<sup>(2)</sup>

Electrostatic precipitators (ESP) are characterized by high collection efficiency (>99%) and moderate operating costs compared with the other three devices. They also are adaptable to small boilers, although the greatest efficiency is obtained with larger systems, such as utility boilers. Variations in fuel characteristics, such as sulfur, alkali, and particle size, can play an important role in determining ESP performance. For oil-fired boilers, ESP efficiency can vary from 45 to 90%, but these devices are not normally used for new installations. They are being used in oil-fired boilers

that originally used coal. With no modifications, an ESP unit originally designed for coal and now used on an oil-fired boiler may only provide about 50% efficiency.<sup>(2)</sup>

Fabric filtration (baghouses) for industrial boilers accounts for about 10% of the market for particulate controls. Collection efficiencies of 96 to over 99% with emission rates of 0.01 to 0.046 lb/10<sup>6</sup> Btu have been achieved on coal-fired boilers. Major factors affecting boilers equipped with fabric filters are additional maintenance requirements, potential corrosion problems, and transient operations. Fabric filters are not normally used for oil-fired devices because of potential damage to filters from the hygroscopic character of oil flyash. At the stringent level of emission control, fabric filters are more cost effective than ESP when low-sulfur coals are used.<sup>(2)</sup>

The use of wet scrubbers for coal-fired boilers has both advantages and disadvantages. The major advantages are (1) the ability to remove both particulates and gases, (2) the ability to function in wet, corrosive, and explosive gas atmospheres, and (3) less space requirements than either ESP or fabric filters. The major disadvantages are (1) energy penalties associated with their operation, (2) poor efficiency for fine particulates, (3) potential water and solid waste problems, and (4) high-pressure drop at equivalent ESP or fabric-filter collection efficiencies. A major factor affecting scrubber performance is the non-steady-state operation of industrial boilers; however, high particulate-removal efficiency can be achieved once steady state is reached. Collection efficiencies of 98% are achievable, although the mass emission rate may exceed standards because of inability to remove fine particulates. Wet scrubbers are not usually used on oil-fired boilers, since oil particulates are usually smaller than 2 microns in diameter and are not readily captured.<sup>(2)</sup>

Mechanical collectors, such as multitube cyclones, have lower particulate-removal efficiencies than the three devices previously described. Their performance is a function of aerosol particulate size, with particles over 10 microns most readily captured. Mechanical collectors are mostly used in conjunction with other control devices to improve efficiencies. By themselves, these systems have emissions rates of 0.19 to 3.05 lb/10<sup>6</sup> Btu, which exceed most state regulations.<sup>(2)</sup>

#### 6.4.2 Sulfur Dioxide Emissions Control

Great strides have been made in recent years to optimize commercial processes for consis-

tent and reliable flue gas desulfurization (FGD). Availability of modern FGD plants has steadily increased an average of 53% in 1978 to 85% in 1981. SO<sub>2</sub> removal systems fall into the following categories:

- wet throwaway systems
- regenerative processes
- dry scrubbing processes.

The throwaway systems produce nonmarketable by-products, while the regenerative systems produce sulfur and sulfuric acid. The dry scrubbing process, which is relatively new to the FGD field, results in particulates that can be collected for disposal. The five commercial FGD processes in use today are Lime/Limestone, Double Alkali, Wellman-Lord, Magnesium Oxide, and Sodium Scrubbing. Each of these processes is discussed briefly below.

Lime and Limestone Process - The lime and limestone FGD processes are similar in many aspects and have gained favor for use with large boilers in the utility industry. Lime/limestone is a wet, nonregenerative SO<sub>2</sub>-absorption process in which the flue gas is contacted with an alkaline slurry in a scrubber/absorber tower. Calcium sulfite and sulfite formed by the reaction are separated from the carrier liquid by setting or filtration, and the solids containing sludge is disposed of in an environmentally effective manner.

Double Alkali Process - Several FGD processes can be characterized as double alkali processes. Double alkali scrubbing is an indirect lime/limestone process that avoids some of the plugging and sealing from using calcium compounds. The double alkali process consists of four basic steps:

- flue gas pre-treatment
- SO<sub>2</sub> absorption
- absorbent regeneration
- solid/liquid separation and solids dewatering.

When particulates are present in the gas stream, they are removed by electrostatic precipitators, wet scrubbers, or other means. The scrubber solution is a mixture of sodium sulfite, sodium bisulfite, sodium hydroxide, sodium carbonate, and sodium bicarbonate. SO<sub>2</sub> reacts with this sodium-based alkali solution to form soluble sulfur oxide salts, which are drawn off in the scrubber bleed stream.

The Wellman-Lord Process - In this process an aqueous sulfite solution is used to

absorb  $\text{SO}_2$ , and sodium bisulfite is formed and then released in a concentrated stream to be stripped and converted to a useful by-product - either liquid  $\text{SO}_2$ , liquid  $\text{SO}_3$ , sulfuric acid, or elemental sulfur. The process is suitable mainly for large installations and utilities. Collection efficiency is better than 90%, but energy use is quite high, averaging between 3.6% and 12% of generation.

Magnesium Oxide (MgO) - This process is also primarily suitable for large installations. With both coal and oil-fired burners,  $\text{SO}_2$  removal >90% has been achieved. The MgO process is a regenerative system in which magnesium sulfite is formed and then dried and calcined to regenerate the MgO for reuse. The sulfur is then processed to the by-product of choice.

Sodium Scrubbing - Nonregenerative sodium-based scrubbing systems are widespread in industrial boilers. About 90% of current industrial FGD systems are nonregenerative sodium scrubbers. Sodium hydroxide is the absorbent in most systems, with sodium carbonate accounting for the balance. If fly-ash is not collected concurrently with  $\text{SO}_2$  absorption, a nonregenerative sodium-scrubbing system produces only a liquid waste stream. Total dissolved solids in the waste stream can be diverted directly into an industrial plant's treatment facilities.

Dry scrubbing processes are relative newcomers to the FGD field. The absorbing liquor is sprayed through atomizers into the  $\text{SO}_2$  and dust-laden exhaust gas. The fine droplets of water will evaporate very quickly. Residence time of actual systems ranges from 10 to 12 seconds. Most of the reaction products can be removed at the bottom of the spray tower; the rest is collected in baghouses or electrostatic precipitators.

#### 6.4.3 Nitrogen Oxides Emissions Controls

Nitrogen oxides ( $\text{NO}_x$ ) formed during combustion result from either thermal fixation of atmospheric nitrogen in the combustion air, or the conversion of chemically bound nitrogen in the fuel. For natural gas and distillate oil firing, nearly all  $\text{NO}_x$  emissions result from thermal fixation, whereas with residual oil and coal, the contribution from fuel-bound nitrogen can predominate. The rate of formation of both thermal and fuel  $\text{NO}_x$  depends highly on combustion conditions, and both are promoted by rapid mixing of the oxygen with the fuel. In addition, thermal  $\text{NO}_x$  is increased by long residence time at high temperatures. Because  $\text{NO}_x$  depends on combustion conditions, control techniques to date have emphasized combustion-process

modifications. These modifications, which are applicable to coal-, oil-, or gas-fired boilers, include the following:

- low excess air (LEA)
- staged combustion air (SCA); overfire air or sidefire air
- low  $\text{NO}_x$  burners
- flue gas recirculation
- reduced air preheat
- load reduction or reduced combustion intensity
- ammonia injection.

These techniques have varying effectiveness in reducing  $\text{NO}_x$  emissions and also have differences in operational, cost, and environmental impacts<sup>(2)</sup>.

For gas turbines, emissions-control techniques for thermal  $\text{NO}_x$  formation include wet systems consisting of water or steam injection, or dry systems consisting primarily of combustion modifications. The formation of thermal  $\text{NO}_x$  is reduced by the following basic techniques:

1. reduce combustion pressure
2. decrease peak flame temperatures in the combustor reaction zone
3. reduce effective residence time of combustion gases at elevated temperature
4. control the amounts of nitrogen and oxygen available for producing  $\text{NO}_x$ <sup>(2)</sup>.

For diesel engines four emission-control techniques or combinations of these techniques have been demonstrated to be effective in reducing  $\text{NO}_x$  emissions: (1) retarded ignition or fuel injection, (2) modification of air-to-fuel ratios, (3) manifold air cooling, and (4) duration of power output. The most effective  $\text{NO}_x$  emission-control technique is fuel injection retard. Both retard and air-to-fuel ratio changes are effective in reducing  $\text{NO}_x$  emissions from dual-fuel engines (those firing both a liquid and gaseous fuel).

## REFERENCES

1. U.S. Environmental Protection Agency (EPA). 1980. Prevention of Significant Deterioration, Workshop Manual. U.S. EPA, Office of Air, Noise, and Radiation, Office of Air Quality Planning and Standards. Research Triangle Park, North Carolina.
2. TRW Energy Engineering Division. 1981. Handbook of Industrial Cogeneration. DOE/TIC-11605, McLean, Virginia.

## 7.0 LEGAL AND CONTRACTUAL ISSUES

This chapter describes laws, regulations, and contractual considerations that affect cogenerators. To obtain the latest information on cogeneration regulations, refer to the Federal Register.

### 7.1 EXISTING LAWS

The original cogeneration legislation was enacted in 1978 as three separate acts:

- The Public Utility Regulatory Policy Act (PURPA)
- The Power Plant and Industrial Fuel Use Act (FUA)
- The Natural Gas Policy Act (NGPA).

Each of these acts is discussed below. Tax legislation that affects cogenerators is discussed in Chapter 4.0.

#### 7.1.1 PURPA

PURPA is the most important piece of legislation for cogenerators. Its purpose is to encourage industrial cogeneration by prohibiting electric utility discrimination and by reducing regulations. Sections 201 and 210, respectively, set the criteria for qualifying facilities and avoided costs. Unless a plant is a qualifying facility, its owners cannot take advantage of any of the federal incentives for cogeneration.

PURPA provides that the Federal Energy Regulatory Commission (FERC), which promulgates the rules under PURPA, can exempt qualifying facilities from state regulation of rate of return and financial disclosure, and from federal regulation under the Federal Power Act and the Public Utility Holding Company Act. It requires utilities to purchase electric power generated by qualifying facilities at rates that are just and reasonable to the rate-payers of the utilities, that are in the public interest, and that do not discriminate against cogenerators. PURPA also mandates that utilities must provide supplementary back-up power to qualifying facilities at nondiscriminatory rates.

State Public Utility Commissions (PUCs) implement the rules promulgated by FERC. A summary of the current status of each PUC's implementation of the FERC rules is presented in Appendix I.

#### 7.1.2 FUA

The purpose of the FUA is to decrease the consumption of oil and gas in certain new

and existing major fuel-burning installations and power plants and to increase the use of alternative fuels. However, the Act provides eligible cogenerators with a permanent exemption from the ban on the use of oil and gas. An exemption may be granted if more than 10% and less than 90% of the useful energy produced by the cogeneration facility is electricity. The cogeneration facility must also demonstrate either (1) that oil or gas savings (over what would otherwise be consumed) will occur, or (2) that the facility will be in the public interest.

#### 7.1.3 NGPA

The NGPA states that incremental cost increases incurred by natural gas suppliers because of deregulation of wellhead prices must be passed on to industrial customers who burn gas in nonexempt boilers. It also authorizes FERC to grant exemptions from this incremental-pricing rule to qualifying cogenerators.

### 7.2 REGULATION

To qualify for the exemptions and benefits under PURPA, a cogeneration facility must obtain qualifying status (Figure 7.1). This can be accomplished by either self-certification or FERC certification. To obtain self-certification, the following must be supplied to FERC:

- name and address of facility
- brief description of facility
- primary energy source
- power production capacity.

To obtain FERC certification, the following additional information must be supplied:

- percentage of ownership held by electric utility
- more detailed description of facility
- installation date
- notice for publication in the Federal Register.

The application should be specific and contain enough information to ensure that all applicable standards are met. Also, calculations should be clearly shown. More information can be obtained from FERC at 825 North Capitol Street, N.E., Washington, D.C. 20426.

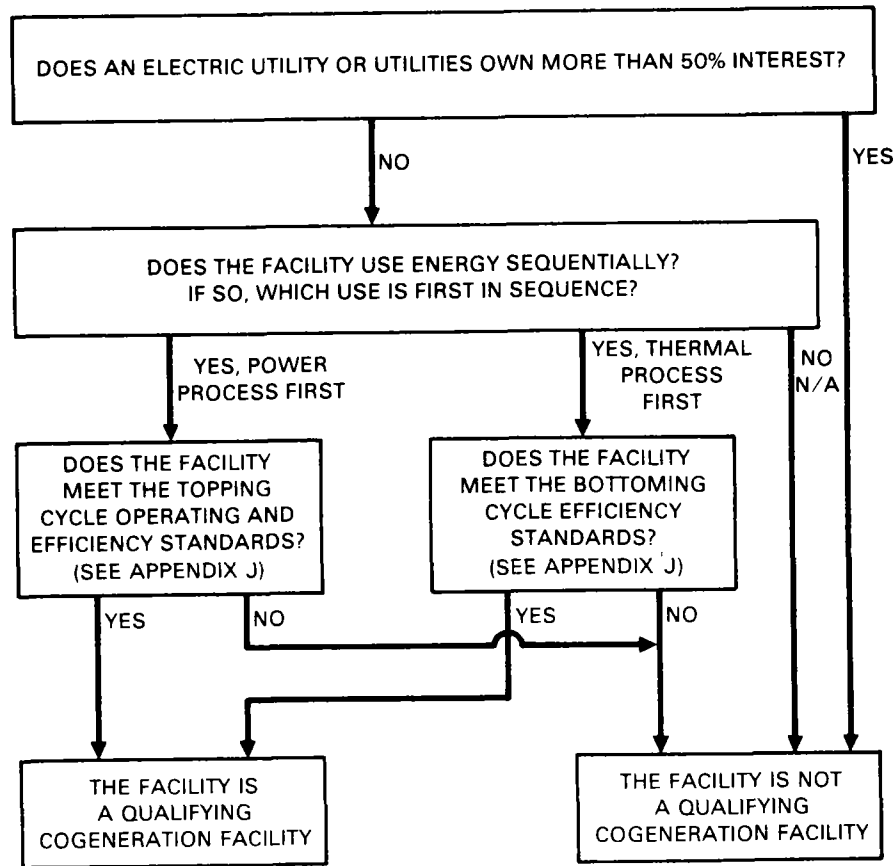

FIGURE 7.1. Determination of Qualifying-Facility Status<sup>(3)</sup>

### 7.3 INTERCONNECTION

This section briefly summarizes the regulatory, technical, and contractual aspects of interconnection of the industrial power-generation equipment into the utility power grid system. Interconnection is not a simple process, and the utilities have not worked out any standard solutions to the technical, economic, or institutional problems of linking up potentially numerous, diverse, and randomly distributed end-user power generation facilities.<sup>(1)</sup>

#### 7.3.1 Regulatory Issues

With enactment of Public Law 95-617, PURPA, and subsequent implementation regulations issued by the FERC, regulated utilities must now agree to the following:

- to interconnect with qualifying cogeneration facilities and small power producers
- to purchase power from the producers at "just, reasonable, and nondiscriminatory" rates

- to offer to supply back-up power if the end-user's facility malfunctions.<sup>(2)</sup>

Although the Supreme Court has recently upheld the rights of states to enforce the Act within their jurisdictions, only 18 state PUCs have done so to date.<sup>(1)</sup>

To meet the requirement that utilities purchase power from qualified producers at just and reasonable rates, FERC issued a set of pricing principles based on the "avoided-cost" concept for use by the PUCs and non-regulated utilities in determining rate structures. Under the "avoided-cost" concept, rates for the power produced by the cogeneration facility are to be based on the costs avoided by the utility in not having to generate the power itself or purchase it from another source.<sup>(2)</sup>

#### 7.3.2 Technical Issues

Present utility power-distribution protective schemes are designed for one-way power flow (from the utility power plant to the customer) and not for the phase-coordinated distribution network required to handle two-way power flow (from the utility to the

customer and vice versa).<sup>(1)</sup> Once an end-user generator is interconnected and begins to operate in parallel with the utility network, it becomes part of a sophisticated system that requires sophisticated and reliable protection to avoid: (1) damage to the system by the generator, (2) damage to the generator by the system, and (3) hazards to personnel who must service the system.<sup>(3)</sup>

In conventional radial one-way distribution systems, overcurrent protection is provided by coordinating the timing of current between fuses, breakers, and reclosers. Fault sensitivity, speed, and response between protective devices is coordinated so that a minimum of equipment on the distribution system is left without power. Connecting a generator in a bi-directional mode can alter the normal fault-current gradient because power can be fed into the system as well as drawn from it. The following are typical interconnection problems that must be addressed.

Utility Breaker Tripping - If, for any reason, the utility breaker should open (e.g., fault clearing), the in-plant generator would become isolated from the system and left coupled to the full plant load and to any adjacent customers that are connected downstream of the tripped breaker. This could result in generator overloading, a drop in voltage and frequency, and, possibly, damaging results<sup>(a)</sup>. If this happens, the nonessential loads must be rapidly shed so the generator output will not be interrupted.<sup>(3)</sup>

Automatic Utility Breaker Reclosing - If the in-plant generator has fallen well out of phase by the time the utility breaker automatically recloses, the resulting shock can be sufficient to shear the generator shaft and cause extensive electrical damage to the system. Because plant breakers cannot operate fast enough to prevent damage, provisions must be made to keep the in-plant generator off-line until the utility system has stabilized.<sup>(3)</sup>

Protective Relays - The purpose of protective relays is to detect unsafe out-of-limit conditions in a power system and to trip appropriate circuit breakers. The most commonly needed relays in an interconnected generation system are over-current, over- and under-voltage, over- and under-frequency, differential, and relays, which govern the direction of power flow. Design

(a) Generator overspeeding could result if power is being fed into the utility grid at the time of breaker opening.

and specification of the relay package is almost always the customer's responsibility, even though the utility may have published guidelines for protection packages and retains final approval authority. Currently, no standards and conventions have been established for interconnection protection and, in most cases, the utilities and customers have not agreed on the trip's limits. The utility's approach is to drop a generator off-line at the moment trouble is detected, whereas the customer's main interest is uninterrupted power to the plant.

### 7.3.3 Contractual Issues

Assuming that one qualifies as a cogenerator or small power producer, the only contractual certainty is that the utility will interconnect. Other terms of the contract will depend largely on negotiations with the utility, including the following:

- payment rates for the power sold to the utility and time of day during which excess power is sold
- allowance for capacity payments
- permissible system maintenance and downtime
- costs for extra switch gear and protection
- standby charges
- power-factor penalty payments.

Negotiations must also include the method for swapping power. Basically, two metering arrangements are used when excess in-plant power is sold to the utility:

- sale of excess power only
- sale of all generated power and simultaneous purchase of all the plant's power needs<sup>(b)</sup>.

In the first case, only one tie line is required. This line is equipped with two in-line watt-hour meters, ratcheted to operate in the opposite direction to the power flow. During normal operations, in-house-generated power flows directly to plant processes, supplemented by utility power as recorded by the "in" meter. When excess power is available, it flows into the grid system and is recorded by the "out" meter. Both meters are usually time-of-day meters, and payments for both purchased and generated

(b) Generally referred to as a "buy-all, sell-all" arrangement.

power are a function of the time of day that the power is delivered.

The "buy-all, sell-all" metering arrangement involves two separate circuits that are individually metered. One circuit handles incoming power, while the other handles outgoing power. This system is designed to take advantage of regulations that require a utility to pay its avoided cost for the power it purchases. Plant power is then purchased at standard industrial rates.

#### 7.4 OTHER CONTRACTUAL CONSIDERATIONS

During the cogeneration system's development and construction, several contractual agreements will be consummated. These could include arrangements with engineering firms, equipment vendors, construction and equipment installation contractors, and the utility company, etc. This section addresses the principal considerations relating to these contractual arrangements.

A satisfactory contract has been defined as one which "...is complete in its offer, free from ambiguity in regard to terms, and sufficiently definite so that the duties and privileges of the respective contracting parties can be ascertained with reasonable facility."<sup>(4)</sup> Unfortunately, the last of these three conditions is frequently the most difficult to develop. The specificity of contracts will vary during the various phases of system development and construction. At the start of preconceptual design, details will be minimal, since the primary objective is creativity in developing feasible options. During the conceptual and detailed-design periods, instructions will become more definitive, while the equipment-procurement, facility-construction, and equipment-installation contracts become extremely specific. Also, the quality of the contacts developed will depend on the degree of participation in their preparation by three parties representing diverse viewpoints -- the owner (i.e., plant management), lawyers, and engineers (both in-house and outside consultants).

##### 7.4.1 The Preconceptual-Design Phase

An outside engineering firm is assumed to be used for this phase of system development. The essential components of the contract will be (1) a statement of work (what is to be done as well as the expected deliveries), (2) a schedule for completion of the work, and (3) an agreement on the fee and method for payment. As mentioned previously, the statement of work will have to be relatively broad in scope at this point. However, it is suggested that the following items be addressed:

- statement of the objective
- location of the proposed facility
- requirements for site visits as appropriate
- whether any energy-related architectural changes/modifications to other portions of the plant are to be incorporated into the design considerations
- location of and extent of historical energy-related data to be made available
- constraints, if any, on types of fuels to be considered
- specification of responsibilities and interface requirements for "barrier assessments"
- identification of a point of contact for data collection, plant-access coordination, and resolution of technical/administrative issues that may arise
- work completion dates (to include interim milestones as deemed appropriate)
- periodic status reporting (written and/or verbal)
- final report and recommendations (both written report and oral presentation to plant management and technical staff).

##### 7.4.2 The Conceptual-Design Phase

If an outside engineering firm has been used during the preconceptual-design phase, it may be advisable to incorporate this phase's activity into the initial contract, if the previous effort has been accepted and if continued system development is feasible. The statement of work for this effort, although similar to that described above, should specify the following:

- the technical option to be further developed and optimized into a conceptual design
- responsibilities and interface requirements for developing environmental assessments, preparing an impact statement, and obtaining regulatory and institutional liaison and approvals
- required deliverables such as
  - system schematics
  - heat-balance calculations
  - outline specifications



- construction schedule and funding estimates
- types of detailed economic analyses required
- progress and final reports
- oral presentations
- schedules for work completion (including interim milestones).
- specify responsibilities and authority and interface requirements among owner, engineer, lawyers (others as appropriate)
- responsibility and authority of engineer to supervise construction and installation, and equipment acceptance
- system check-out
  - develop check-out procedures and specifications
  - supervise system check-out
  - train plant personnel
- utility interface responsibilities and authority for system interconnection.

#### 7.4.3 The Final Design and Construction Phase

For this discussion, the outside engineer is assumed to be responsible for both the detailed design of the final system and for the coordination, technical supervision, and approval of the technical efforts related to the facility construction. In this case, several contractual arrangements will be required:

- between owner and engineer to define responsibilities for system design, construction supervision, and system check-out
- between owner and equipment suppliers to include the engineer's responsibilities and authority to approve equipment changes, substitutions, and products
- between owner and contractor(s) to include the engineer's responsibilities and authority to supervise construction, approve work validation of work for progress payments, and approve changes and/or modifications of work.

Each of these contract arrangements is discussed in more detail below.

The Owner-Engineer Contract - This contract should address the following issues:

- system design
  - develop design drawings
  - develop system, equipment, facility-construction and equipment-installation specifications
  - develop and interface requirements for equipment-procurement packages, facility-construction contract documents, and equipment-installation contract documents
- advertising, bidding, proposal evaluation, contract award

The Owner-Equipment Supplier Contracts - Principal issues to be addressed in these contracts (purchase orders) include the following:

- equipment specifications
- delivery schedules
- completeness of systems (e.g., what is "standard" and what are the "add-on" components required for complete installation
- costs and payment conditions
- system-acceptance conditions
- authority and responsibilities of engineer as owner's "agent"
- late-delivery penalties (as appropriate)
- installation responsibilities (as appropriate)
- technical assistance
- publications, spare parts, special tools, etc.

The Owner-Contractor Contract(s) - Issues to be addressed in these contracts include the following:

- contractual documents (e.g., drawings, specifications, special contract clauses)
- construction schedules
- quality of workmanship/materials
- responsibilities of contractor, engineer, and others (as appropriate)
- resolution of disputes

- inspection of work, approval of changes, substitutions, etc.
- inspection of materials, shop drawings, and critical phases of work (e.g., authority to proceed to next phase, such as forms, concrete pouring, etc.)
- interfacing responsibilities among multiple contractors (if applicable)
- payment schedules and conditions of payment
- bonding requirements, responsibilities for permits and insurance
- compliance with local ordinances, safety laws, labor laws, etc.
- responsibility for work space, utilities, and telephones
- construction of temporary access roads (if required), material storage sites, and responsibility for removal at end of job
- final acceptance of work
- penalty conditions
- routing and plant access for construction equipment, materials delivery, and construction personnel.

#### REFERENCES

1. Reason, J. 1982. "Making Interconnection Work." Power.
2. Wetzler, F. V. 1982. "Connecting Renewable Power Sources into the System." IEEE Spectrum.
3. TRW Energy Engineering Division. 1981. Handbook of Industrial Cogeneration. DOE/TIC-11605, McLean, Virginia.
4. Dunham, C. W. and R. D. Young. Contracts, Specifications, and Law for Engineers, 2nd Ed. McGraw-Hill Book Company, New York, New York.

Assessing the potential for cogeneration, selecting an optimal system configuration, and subsequently designing, acquiring, and installing the system will, in most cases, involve many participants performing various tasks over an extended period of time. Whether in-plant personnel or outside specialists perform the tasks, data must be collected and analyzed, designs created, specifications prepared, components and materials purchased, and the system constructed and tested. Also, extensive coordination with regulatory agencies and the utility company will be required throughout the project. The success of the project will largely depend on assignments of actions and responsibilities through clear-cut directives, work statements, and contractual documents.

To provide a basis for developing these directives, work statements, and contractual documents, this chapter addresses the typical events and schedules for designing and installing a cogeneration system and identifying principal components of various cogeneration configurations. To further help project planning and specification preparation, a comprehensive project checklist and a summary of principal codes and standards for mechanics, structural, and electrical design are included. Interconnection of the cogeneration system into the utility's power grid system and other general contractual guidelines were discussed in Chapter 7.0.

### 8.1 COGENERATION SYSTEM DEVELOPMENT

The various activities beginning with the initial data collection and analysis to determine the potential for cogeneration and ending with the final check-out of a completed system can be grouped into the following three phases:

- Preconceptual Design
- Conceptual Design
- Detailed Design and Construction.

The major activities in each of the phases and the interrelationships among these events are depicted on flow charts in this chapter, while more detailed activities related to these events are outlined in appendices. Not all phases, events, or activities will be applicable in all real-life situations, nor are all activities distinctly unique. Some steps may be eliminated, while others may merge or overlap. The intent here is to provide a model that depicts the basic thought processes and the planning sequences involved. The energy manager is encouraged to delete, modify, or

substitute details to fit his own individual requirements.

#### 8.1.1 The Preconceptual-Design Phase

The preconceptual-design phase can be broadly defined as the period during which 1) data are collected, analyzed, and evaluated to decide whether cogeneration represents a feasible and practical option, and 2) if the decision is in the affirmative, which system configuration and "modus operandi" should be further developed for subsequent implementation. Generally, the activities associated with this phase can be grouped into four categories:

- Project Plan Development
- Load Analysis
- Options Analysis
- Trade-Off Analysis, Option Selection, and Final Economic Evaluation.

The significant activities associated with the preconceptual-design phase are shown in Figure 8.1. Activities associated with the numbered events are outlined in more detail in Appendix J. Each of the four categories in this phase is described below.

##### Project Plan Development

As previously indicated, developing a cogeneration system is a lengthy and complex process. Therefore, developing a comprehensive project plan is a necessary first step to help administer efforts to tightly control costs, scheduling, and quality. The plan should 1) define the overall scope of work, 2) identify the specific tasks to be accomplished, 3) establish schedules for task completions, and 4) specify the methodologies to be used. Also, the plan should indicate what in-house and/or outside resources will be made available. Lastly, (and perhaps most importantly), the plan should describe the organizational structure that will be used to accomplish the required work, and clearly define the duties and responsibilities of the various project participants. In summary, the plan defines what is to be done, how it is to be done, by whom, and when it is to be completed.<sup>(a)</sup>

(a) If the proposed project will involve upgrading and/or modifying an existing operational plant, the plan should include provisions for minimizing the impact on on-going production operations throughout all design phases and during cogeneration plant construction.



The plan is a working document to be used throughout all phases of the project. It should be expanded, updated, or revised as situations dictate. A well-developed plan that all participants understand will minimize costly oversight or redundancy of efforts and serve as a baseline for evaluating progress.

### Load Analysis

Load-analysis activities involve determining existing and projected energy requirements. Metered or recorded information on fuel, steam, and electrical consumption and their costs should be collected for several years of prior operation. Based on these data, daily, seasonal, and annual load-duration curves should be developed to determine peaks and minimums in energy consumption that can then be used in sizing the cogeneration system. The loads that will or will not be served by the proposed cogeneration system should be identified also. When developing the future thermal and electrical load estimates, the potential impact of planned energy-conservation measures (ECMs) and/or plant expansions must also be considered.

Although not technically a load-analysis activity, the existing thermal and electrical systems should be inspected while data are being collected. This inspection will identify components that will need to be upgraded or replaced when the cogeneration system is installed. Identifying these components will help make total-system cost estimates more realistic during later stages of the evaluation process.

### Options Analysis

As indicated in Figure 8.1, events and activities associated with the analysis of possible cogeneration options can be grouped into four general categories:

- Constraint Assessment
- Development of Candidate Cogeneration Configurations
- Financial Data Collection
- Options Analysis and System Ranking.

Constraint assessment involves 1) identifying broad institutional, regulatory, and environmental issues that could present barriers to successfully implementing a cogeneration project, 2) identifying actions that could eliminate expected barriers, and 3) to the extent possible, developing rough (order-of-magnitude) cost estimates for overcoming the various constraints.

Developing candidate cogeneration configurations involves several parallel and sequential activities: 1) assessing existing technologies to identify available techniques, types of equipment available, and their performance capabilities, 2) selecting potential fuels or combinations of fuels that would be compatible with plant operational requirements, and 3) identifying and evaluating potential sites for placing a cogeneration system. As this information is assembled and synthesized, various cogeneration configurations can be developed, and major components can be selected and sized to accommodate the projected loads. Finally, those configurations that appear technically feasible in terms of fuel use, site compatibility, and optimal sizing of components to satisfy projected loads can be identified for further evaluation.

Financial data collection activities include 1) developing cost estimates for each of the technically feasible cogeneration configurations, 2) developing costs for facility modifications and existing-systems upgrading to accommodate each cogeneration option, 3) estimating fuel and operating costs, 4) identifying "barrier"-related costs, and 5) identifying costs of the various forms of system acquisition, ownership, and operation.<sup>(a)</sup>

Once the technically feasible configuration options have been determined, the appropriate cost data for each option collected, and the constraints identified, the various options can be ranked in terms of cost and suitability of performance.

### Trade-Off Analysis, Option Selection, and Final Economic Evaluation

The trade-off analysis involves evaluating the pros and cons of the ranked systems. Hardware costs may outweigh the desired energy-output level or vice versa. Environmental or institutional factors may be significant considerations under certain circumstances. In essence, the trade-off analysis leads to selecting a cogeneration configuration that will provide an acceptable energy supply at an acceptable investment and operational cost, while satisfying various regulatory restrictions. Once a cogeneration configuration has been selected, a final economic evaluation can be made, which takes into account such factors as ownership possibilities, methods of financing, return-on-investment considerations,

---

(a) Factors associated with ownership options are considered later in the final economic analysis.

life-cycle costs, tax implications, etc. This final economic evaluation is geared to management's viewpoint on how to obtain and operate a system that has been deemed technically acceptable for the job at hand.

### 8.1.2 The Conceptual-Design Phase

Assuming that the results of the preconceptual-design phase are positive, the selected cogeneration option is further developed during the conceptual-design phase to the level of detail required for subsequent final engineering and construction.<sup>(a)</sup> Principal activities during this phase include the following:

- Subsystem Optimization
- Site and System Layouts
- Preparation of Preliminary (Outline) Specifications
- Refinement of Cost Estimates
- Development of Construction and Funding Schedules
- Regulatory and Environmental Compliances
- Refined Life-Cycle-Cost Analysis.

The significant activities in the conceptual-design phase are depicted in Figure 8.2. Activities associated with the numbered events are outlined in more detail in Appendix K. Each of the activities in this phase is described below.

#### Subsystem Optimization

Subsystem-optimization activities include developing detailed system schematics and calculating energy balances. All required components are identified and optimized for size, operating pressures, and temperatures.

#### Site and System Layouts

The selected site is further analyzed to determine suitable locations for the cogeneration system and support facilities (fuel storage and handling, waste disposal, transportation routes, etc.). Site layouts are prepared reflecting the proposed system configuration and location of major system components.

---

(a) Unless expertise is available within the company, the first step in accomplishing this phase's work must be to select an engineering consulting firm.

#### Preparation of Preliminary (Outline) Specifications

After the conceptual design has been stabilized, outline specifications are prepared for all major components and subsystems, indicating performance characteristics, type, and general features.

#### Refinement of Cost Estimates

Refining cost estimates includes 1) pricing major components based on vendor estimates, 2) developing detailed cost estimates for final engineering design, 3) estimating construction and equipment installation costs based on established engineering data and regional labor and material rates, and 4) refining O&M cost estimates based on the more definitive system design.

#### Estimation of Construction and Funding Schedules

Based on the conceptual design, vendor information on delivery lead times for system components, and expert engineering knowledge of construction practices, the engineer will develop construction time estimates and schedules for accomplishing the required work. Based on these schedules, a funding schedule will be developed to depict the required financial outlays throughout the project. As appropriate, these estimates will usually account for anticipated escalation and all costs of grid interconnection.

#### Regulatory and Environmental Compliances

During this period, activities include 1) detailed assessment of regulatory, institutional, and environmental regulations, 2) liaison with appropriate government agencies, and 3) preparation of forms leading to the issuance of required certifications, permits, and/or licenses. If required, an Environmental Impact Statement is also prepared at this time.

#### Refined Life-Cycle-Cost Analysis

Using the refined cost estimates developed during the conceptual-design phase, a more detailed economic analysis is performed. An assessment is made of the effects on the system life-cycle costs to provide management with the necessary assurances for continuing the project.

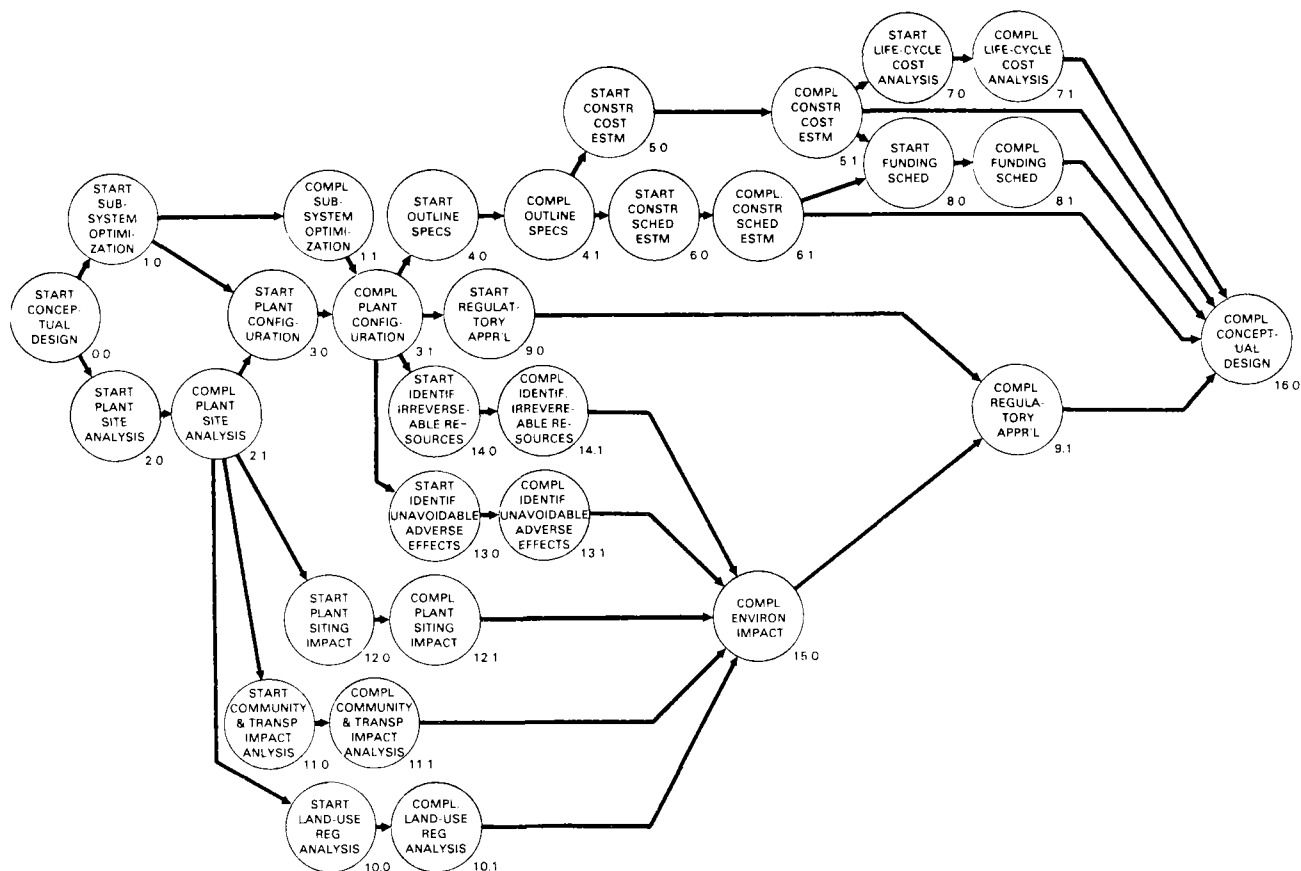

FIGURE 8.2. Conceptual-Design Phase

### 8.1.3 The Detailed Design and Construction Phase

The principal events in this phase include the following:

- Detailed Design of the Cogeneration System
- Preparation of Detailed Specifications
- Preparation of Contractual Documents
- Advertising, Bidding, Proposal Evaluation, and Construction Contract Award
- Facility Construction, System Installation, and Utility Interconnection
- Initial Operation and System Check-Out.

The activities associated with this project phase are shown in Figure 8.3. Activities associated with the numbered events are outlined in more detail in Appendix L. Each of the activities in this phase is described below.

### Detailed Design of the Cogeneration System

Based on the conceptual design, the detailed design is started. All essential features of the project must be determined, designed, dimensioned, and developed in enough detail for potential contractors to prepare their cost estimates. Engineering drawings developed during this period become the "contract drawings" upon which the final system will be based.<sup>(a)</sup> Long-lead-time items (such as turbines generators, boilers, etc.), which must be ordered before the design is completed and before the construction contract is awarded, must also be identified during this period.

#### Preparation of Detailed Specifications

Initial emphasis is on developing detailed equipment specifications to facilitate placing orders for long-lead-time items. Once

(a) After contract award, the contractor most likely will prepare more detailed "shop" or "working" drawings.

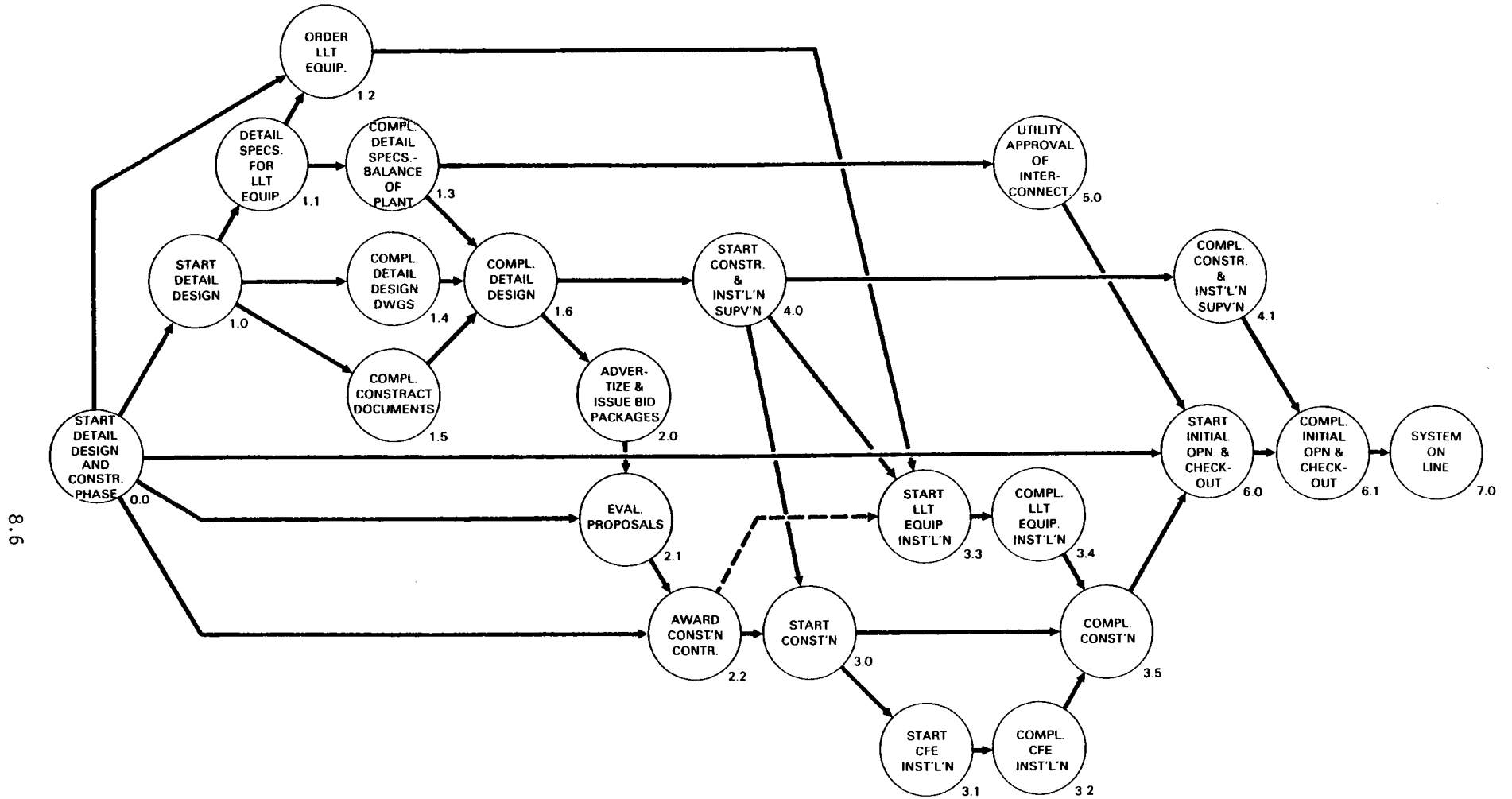

FIGURE 8.3. Detailed-Design-and-Construction Phase



detailed design drawings have been developed in enough detail, drafting of the remaining specifications for the balance of plant equipment and plant construction begins. Specifications for initial operation and system check-out should also be developed at this time.

#### Preparation of Contractual Documents

This activity encompasses 1) compiling all necessary design drawings and specifications, 2) drafting special provisions that delineate and describe the work to be performed, qualities of materials, quality of workmanship conditions, and schedules for payments, and 3) considering other various conditions governing operations and the results to be obtained. Also, the engineer, together with the owner, will determine the type of contract to be awarded.<sup>(a)</sup>

#### Advertising, Bidding, Proposal Evaluation, and Contract Award

The decision must be made as to whether bids will be openly solicited or confined to one or more specialized or prequalified firms. Other activities include developing and publishing bidding requirements, fees (if any), proposal formats, proposal-evaluation standards, and conditions and timing of contract award. Stipulations may also be included for rejecting all bids (particularly if submitted bids exceed the planned financial threshold for the project).

#### Facility Construction, System Installation, and Utility Interconnection

Although the activities during this phase are basically defined in the various contractual documents, provisions must be made for engineer oversight, coordination, technical arbitration, periodic inspection, verification of work progress, and approval of changes (if required).

(a) Although this discussion is primarily oriented toward the "construction" contract, similar actions may be required if separate contracts are awarded for equipment installation, etc. Additionally, if such is the case, the interfacing activities among multiple contractors on the job site must be clearly defined in all contractual documents. Contractual documents should also indicate the responsibilities and relationships of equipment suppliers, etc. during the all-important system check-out period.

#### Initial Operation and System Check-Out

Once construction of the cogeneration system is completed, a period of time should be allocated for initial operation of the system before formally placing the system on-line. This period will provide for system check-out, de-bugging, accumulating performance data, testing operational procedures, and training personnel.<sup>(b)</sup> Final inspections of interconnection and safety equipment will be made by the utility to insure that the system is fully acceptable for two-way power transmission.

#### 8.2 TYPICAL SYSTEM DEVELOPMENT AND CONSTRUCTION SCHEDULE

Developing and constructing a cogeneration system usually takes about three years. In general, the preconceptional data collection, analysis, option selection, and subsequent conceptual-design optimization can be accomplished within a year. The remaining time is required for the detailed design, preparation of specifications, ordering of the long-lead-time equipment, and the subsequent construction contracting, construction, and check-out. Figure 8.4 shows a typical development and construction schedule. The events depicted correspond to the principal events shown in Figures 8.1 through 8.3.

#### 8.3 TYPICAL MAJOR SYSTEM COMPONENTS

To facilitate the selection of components when preparing estimates for various potential cogeneration configurations, Figures 8.5 through 8.9 have been prepared in a top-down breakout format depicting the following configurations:

- steam turbine
  - coal-fired
  - oil- or gas-fired
- gas turbine
- combined cycle
- diesel.

#### 8.4 USE OF STANDARD SPECIFICATIONS

The proper writing of specifications requires comprehensive knowledge of the particular items to be specified, plus an

(b) As indicated previously, it is highly recommended that during this period equipment vendors participate in accordance with specified conditions in the equipment-acquisition contracts.

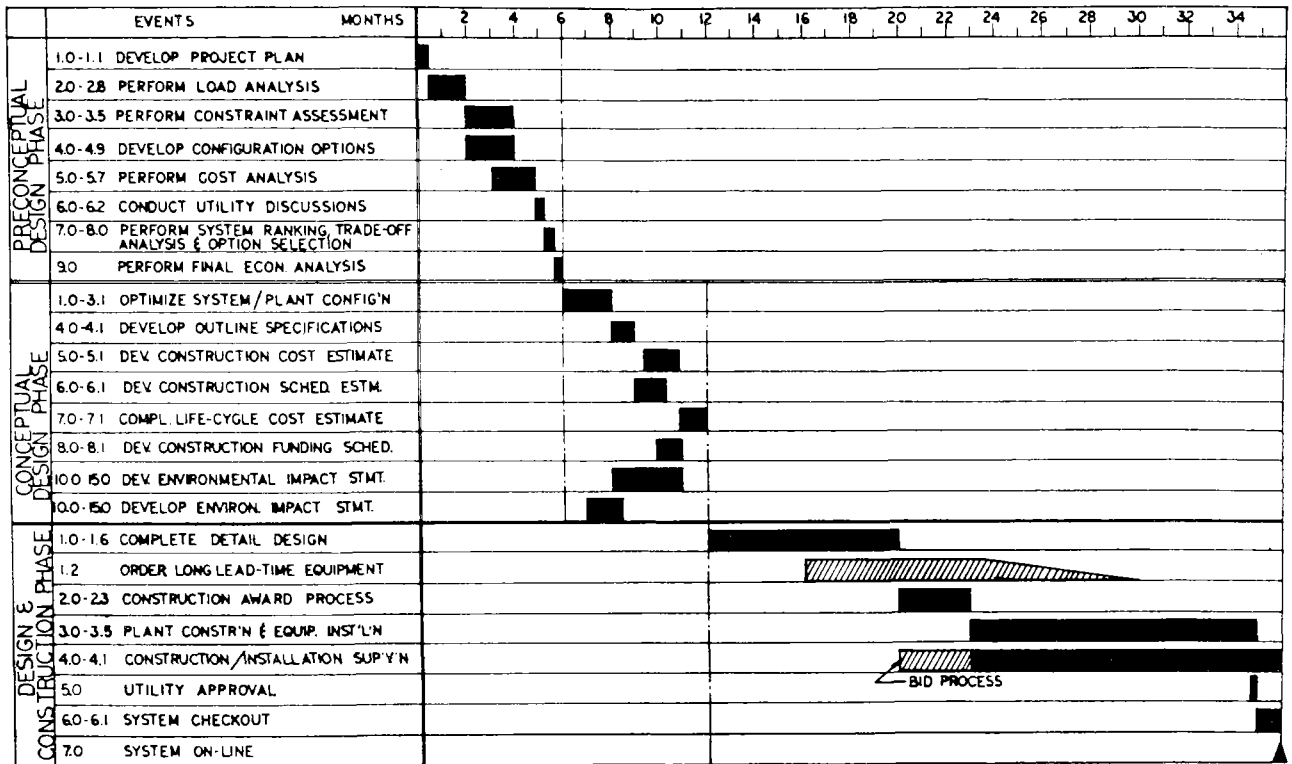

FIGURE 8.4. Typical Cogeneration System Development and Construction Schedule

ability to express one's ideas adequately in written form. Because specifications for many items will be required, it is helpful to refer to "standard specifications" whenever appropriate. These specifications are the result of intensive study by experts in each field and are generally accepted as authoritative. A list of the more common "standards" applicable to mechanical, structural, and electrical-design considerations has been compiled in Appendix M. The list is not comprehensive, but represents an initial list for considering and identifying the professional organizations responsible for developing and publishing "standards" and codes within specific subject areas.

### 8.5 PROJECT CHECKLIST

Developing a project plan, compiling lists of subsystem components, identifying items requiring the citation of specifications, and/or developing work-breakdown structures to identify tasks and subtasks can be frustrating. One is consistently plagued with the nagging thought "...what have I left out?" Appendix N contains a project checklist for determining items to be addressed. Not all listed items are applicable in all cases, nor is the list intended to be a complete listing of activities and components for a cogeneration system. Rather, it is provided as an initial "shopping list" for getting started.

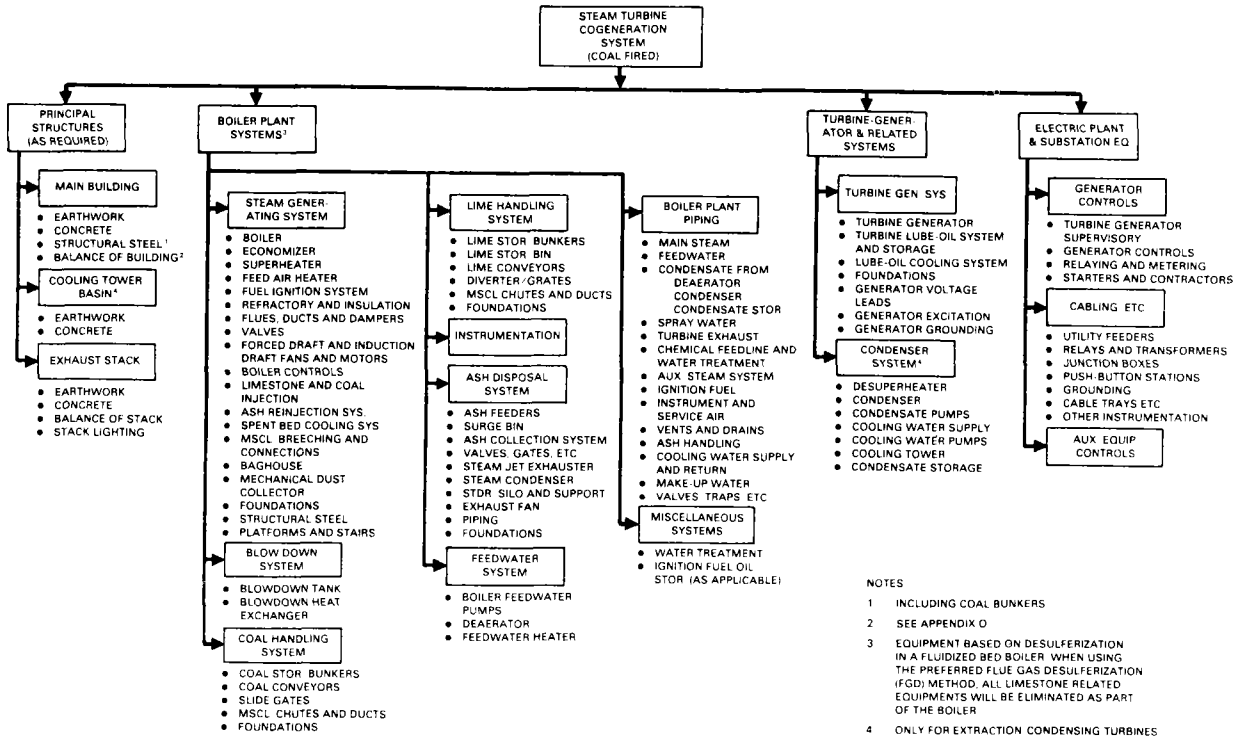

FIGURE 8.5. Equipment Breakdown - Steam Turbine Cogeneration System (coal-fired)

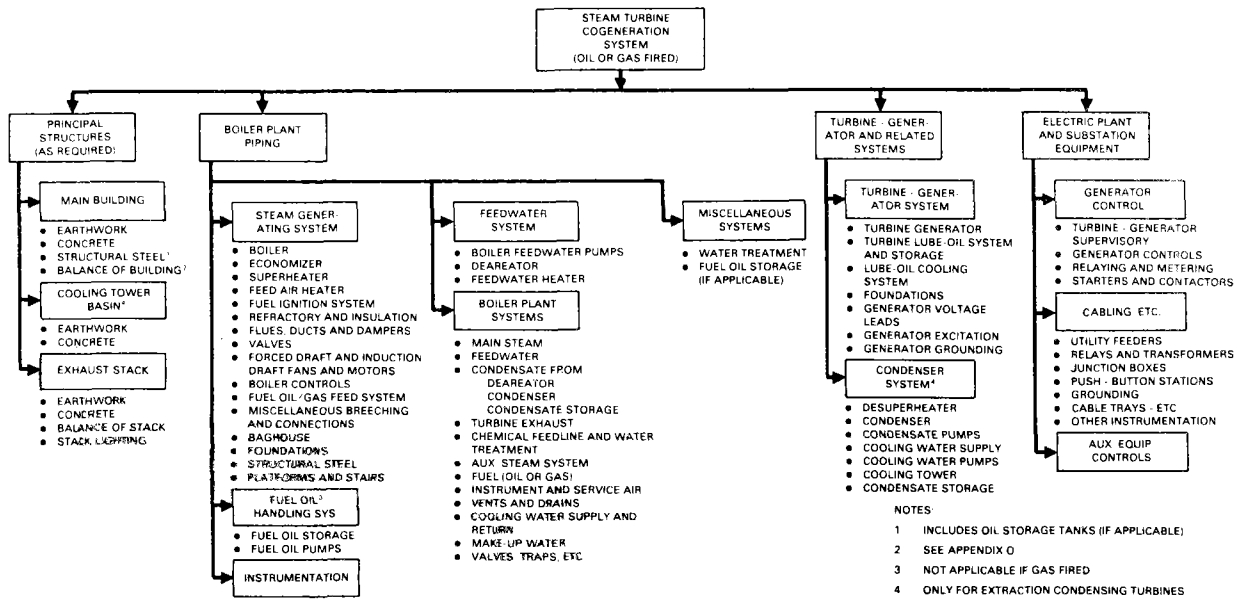
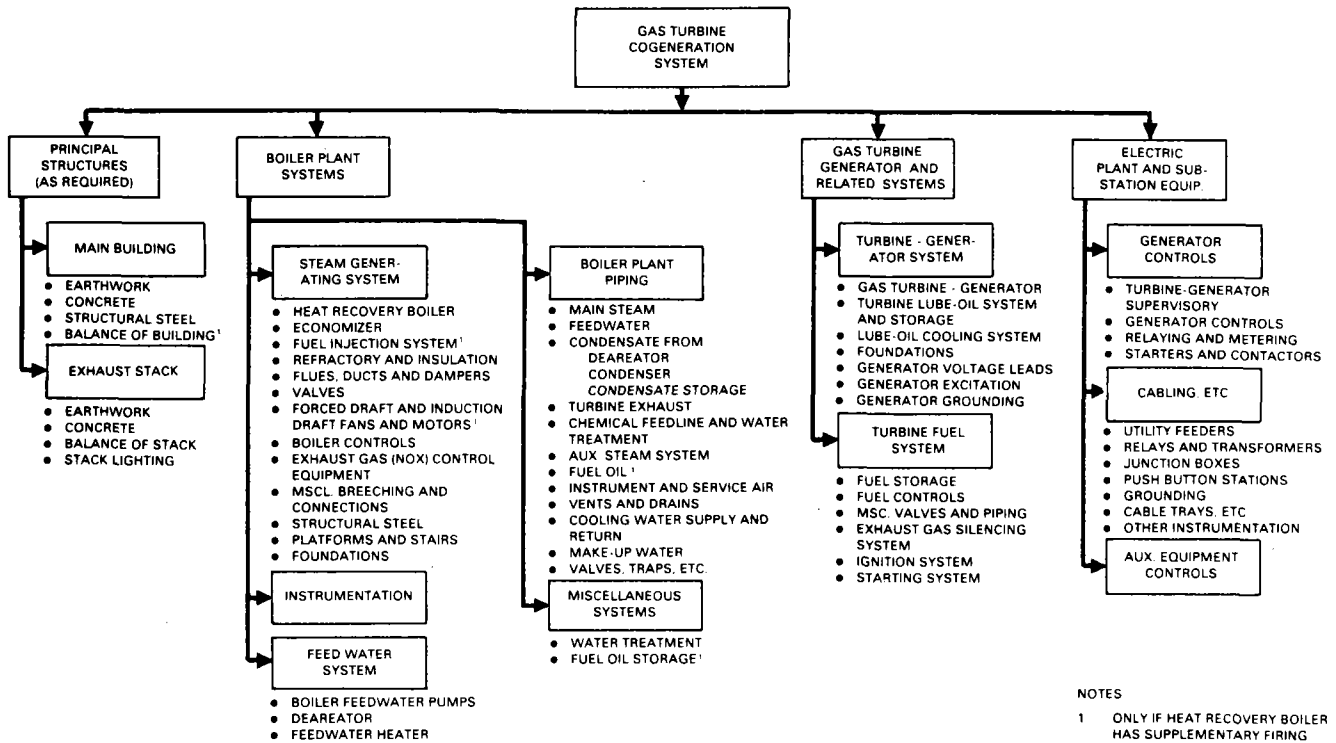
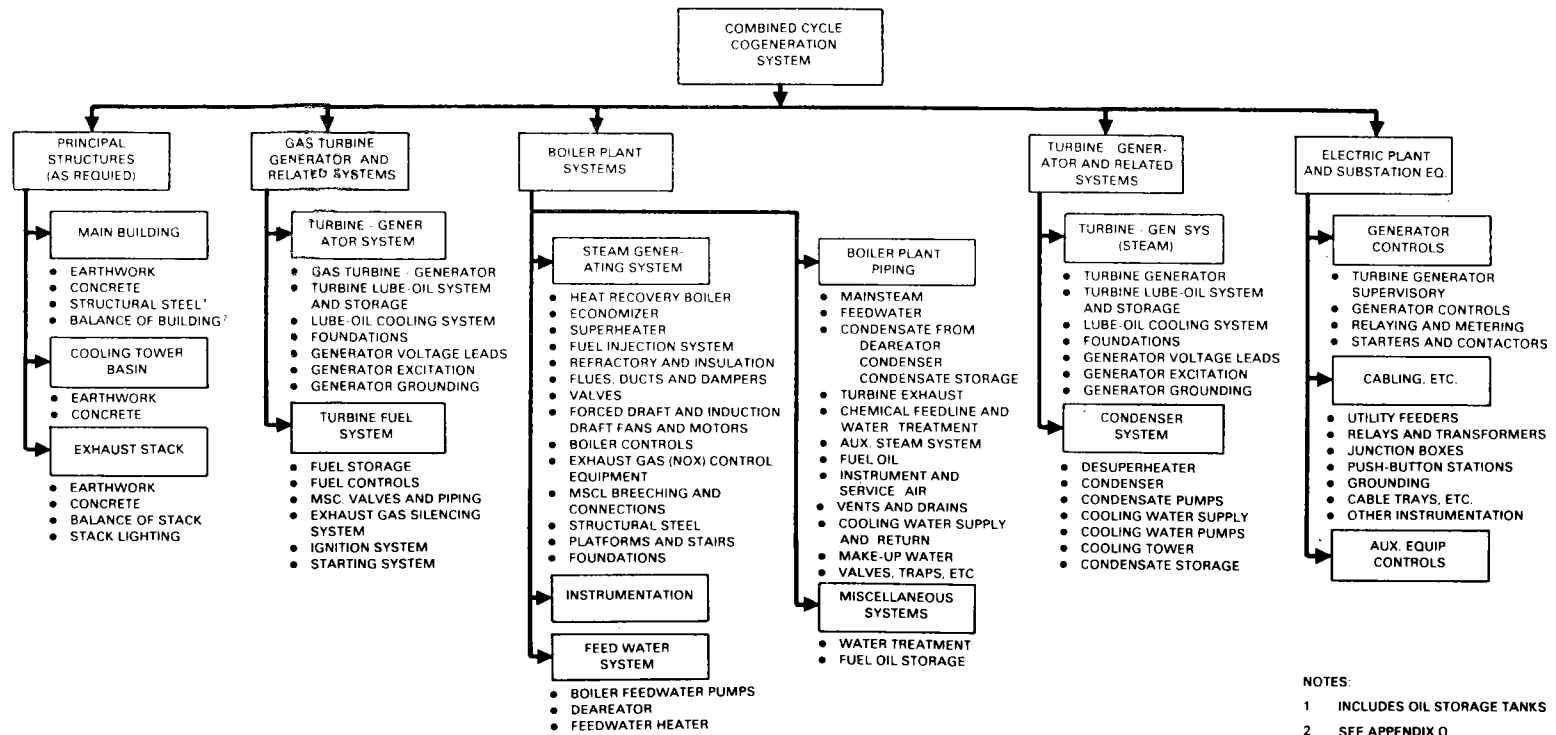

FIGURE 8.6. Equipment Breakdown - Steam Turbine Cogeneration System (oil- or gas-fired)



**FIGURE 8.7. Equipment Breakdown - Gas Turbine Cogeneration System**



**FIGURE 8.8.** Equipment Breakdown - Combined-Cycle Cogeneration System

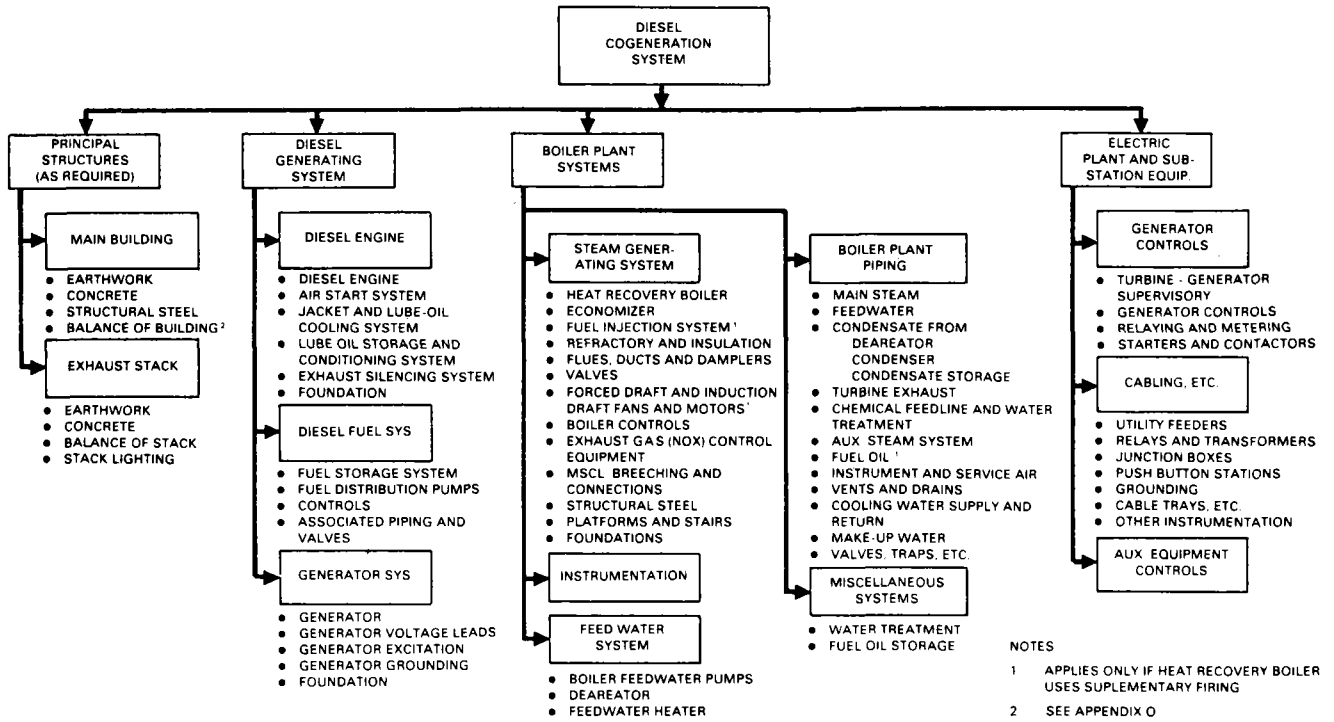

FIGURE 8.9. Equipment Breakdown - Diesel Cogeneration System

## ADDITIONAL RESOURCES

### BIBLIOGRAPHY

TRW, Inc. October 1981. Handbook of Industrial Cogeneration. DOE/TIC-11605. Prepared for the U.S. Department of Energy, Washington, D.C.

This generalized handbook provides information on cogeneration systems, potential applications, investment and savings analyses and environmental, legal and regulatory considerations. Each of the sections is illustrated with examples from the chemical and petroleum industries.

Argonne National Laboratory. June 1981. Environmental Assessment on Industrial Cogeneration Plant at the Riegel Textile Mill Site, Ware Shoals, South Carolina. DOE/TIC/11486. Prepared for the U.S. Department of Energy, Washington, D.C.

This report examines the potential environmental, health and safety, and socioeconomic impacts of the proposed cogeneration demonstration plant at the Riegel Textile Corporation plant at Ware Shoals, South Carolina. The Ware Shoals plant is a weaving, dyeing and finishing plant, which has been in operation since 1902. The proposed cogeneration cycle is to provide both medium- and low-pressure process steam, with electricity produced as a by-product. The proposed system will consist of a coal-fired, high-pressure, high-temperature boiler coupled to a noncondensing turbine generator, which exhausts at the required process pressure.

Argonne National Laboratory. September 1979. Barriers to the Adoption of Energy-Conserving Technologies in the Textile Industry. ANL/CNSV-TM-57. Argonne National Laboratory, Argonne, Illinois.

This report contains an overview of the textile industry and a discussion of energy-conserving technologies currently available or at the pilot-demonstration stage. Cogeneration is included as one of these technologies. Existing and potential barriers to the adoption of these technologies by the textile industry are discussed.

Office of Technology Assessment. February 1983. Industrial and Commercial Cogeneration. U.S. Government Printing Office, Washington, D.C.

This report provides an evaluation of the economic, regulatory, and institutional barriers to the development of cogeneration systems by utilities, industries and businesses. The report describes currently available and potential future cogeneration technologies, including their likely costs and operating characteristics, and reviews the potential applications for these technologies in industry, commercial buildings and agricultural areas.

California Energy Commission. September 1982. Cogeneration Handbook. P500-820-054. Sacramento, California.

The purpose of this handbook is to make business and industry managers aware of the potential benefits offered by this "off-the-shelf" technology. The handbook is designed to enable potential cogenerators to evaluate the technical, economic, and institutional feasibility of initiating a cogeneration venture. The book is intended for the plant engineer or energy manager seeking to assess site-specific potential for cogeneration. Chapter 2 presents a first-cut feasibility assessment of a site's potential for cogeneration. If the characteristics of a particular site meet the minimum requirements to support a cogeneration facility, a detailed assessment of technical and economic feasibility should be undertaken as described in Chapter 3. Financing and ownership options are discussed in Chapter 4, regulatory requirements are summarized in Chapter 5, and details of California's air quality requirements are presented in Chapter 6.

Regulatory Policy Institute. January 1983. The Industrial Cogeneration Manual. Washington, D.C.

This manual is designed for the plant manager or others with the ability to initiate corporate decisions. Detailed information on the regulatory, environmental, engineering, contractual, financial and tax aspects of cogeneration is provided. Owners of the manual can subscribe to a monthly publication, The Industrial Cogeneration and Small Power Production Monthly, which provides a means of periodically updating the manual.

Gerlaugh, et al. September 1979. Cogeneration Technology Alternatives Study (CTAS) - General Electric Final Report. DOE/NASA/0031-80/1. General Electric Company, Schenectady, New York.

This study examines the use of various advanced energy-conversion systems and compares them with each other and with current-technology systems for their savings in fuel, costs, and emissions in individual plants and on a national level. About 50 industrial processes from the largest energy-consuming sectors were used as a basis for matching a similar number of energy-conversion systems that were considered as potential candidates in the 1985 to 2000 time period. The sectors considered included food, textiles, lumber, paper, chemicals, petroleum, glass, and primary metals. The energy-conversion systems included steam and gas turbines, and fuel cells. Fuels considered were coal, both coal and petroleum-based residual and distillate liquid fuels, and low-Btu gas obtained through the onsite gasification of coal.

Atmospheric and pressurized fluidized-bed steam-turbine systems are the most attractive of the direct coal-fired systems. Open-cycle gas turbines with heat-recovery steam generators and combined-cycles with NO<sub>x</sub> emission reduction and moderately-increased firing temperatures are the most attractive of the coal-derived liquid-fired systems.

International Cogeneration Society Research Institute. Cogeneration World. Washington, D.C.

This monthly awareness journal features articles on current engineering, economic and regulatory developments that impact cogeneration. Regular departments provide information on recent legislative and regulatory decisions, case studies of actual installed cogeneration systems, and profiles of corporations that provide cogeneration equipment, and technical and financing services.

#### OTHER COGENERATORS

West Point Pepperell (apparel fabrics, cotton)  
Lindale Mill  
Lindale, GA 30147

Springs Mills, Inc. (polyester/cotton sheeting)  
N. White Street  
P. O. Box 70  
Ft. Mill, SC 29715

Riegel Textile Corporation (Terry towels, apparel  
East Main Street fabrics, baby blankets,  
P. O. Box 329 cloth diapers)  
Ware Shoals, SC 29692



## GLOSSARY

ACRS - Accelerated Cost Recovery System

A&E - Architectural and Engineering Firm

Back-Pressure Steam Turbine - Steam, generated in a boiler, is used in a turbine/generator to produce electricity. Steam is discharged from the last stage of the turbine at pressures needed for industrial process use.

RACT - Rest Available Control Technology

Baseload - The minimum amount of electric power that is generated or supplied continuously.

Bottoming Cycle - The use of low-temperature waste heat from an industrial process to generate electricity. Steam or an organic fluid can be used as the working fluid.

Capacity Factor - The ratio of the average load on a machine or piece of equipment for a given period of time to the maximum capacity of the machine or equipment.

Capital Cost - Installed cost of additions, improvements, and replacements or expenditures for the acquisition of existing facilities.

Central Power Generation - A utility generates electricity at a large plant, the primary purpose of which is to generate electricity.

CFR - Code of Federal Regulations, published by the Office of the Federal Register, available from U.S. Government Printing Office. References to CFR cited by volume and part; e.g., 10 CFR 500.2 is Volume 10 of the Regulations, beginning with part 500.2.

Cogeneration - The sequential production of electricity, or shaft power, and useful thermal energy from the same fuel source.

Combined Cycle - Waste heat from a gas-turbine topping cycle is used to produce steam in a waste-heat boiler. The steam is used to generate electricity in a steam turbine/generator.

Condensing Steam Turbine - Steam, generated in a boiler, is used in a turbine/generator to produce electricity. Steam exhausted from the last stage of the turbine is condensed and recycled to the boiler.

DCF - Discounted Cash Flow

DDB - Double-declining balance depreciation

Demand Charges - Part of the utility service charge determined on the basis of possible maximum demand as distinguished from actual energy consumption.

DOE - Department of Energy

Enthalpy - Heat content

EPA - Environmental Protection Agency

ERTA - Economic Recovery Tax Act of 1981

ESP - Electrostatic precipitator

ETA - Energy Tax Act of 1978

Extraction Steam Turbine - Steam, generated in a boiler, is used in a turbine/generator to produce electricity. Steam is extracted at different pressures from intermediate stages of the turbine for use in industrial processes. The steam from the final stage is condensed and returned to the boiler.

FERC - Federal Energy Regulatory Commission

FGD - Flue-Gas Desulfurization

FR - Federal Register; references to the Federal Register cited by volume, page number, and date; e.g., 44 FR 28950 (6 June 1980), etc.

FUA - Powerplant and Industrial Fuel Use Act of 1978.

Gas Turbine - A prime mover that converts the energy of a fuel into work by using compressed, hot gas as the working medium.

Grid - A utility's power generation, transmission, and distribution system, including transmission lines, transformer stations, etc.

HC - Hydrocarbon - Usually used in reference to air pollutant emissions.

Heat Flow - The amount of heat transferred in a unit of time.

Heat Rate - A measure of generating station thermal efficiency, generally expressed in Btu per net kilowatt-hour. It is computed by dividing the total Btu content of the fuel burned for electric generation by the resulting kilowatt-hour generation.

IHR - Incremental Heat Rate - The ratio of fuel consumed minus heat supplied to the net power output of the prime mover.

Interruptible Power - Power made available under agreements that permit curtailment or cessation of delivery by the supplier. Advance notice of 1 to 1-1/2 hours is usually given prior to the interruption.

Investment Tax Credit - A specified percentage of the dollar amount of new investment in each of certain categories of assets that a firm can deduct as a credit against its income tax.

IRR - Internal Rate of Return - The discount rate that equates the present value of expected future receipts to the cost of the investment outlay.

LAER - Lowest Achievable Emission Rates

LEA - Low Excess Air

Load - The amount of energy delivered or required at any specified point or points on a system.

Load Duration Curve - Energy use as a function of time.

NAAQS - National Ambient Air Quality Standards

NEA - National Energy Act of 1978

NGPA - Natural Gas Policy Act of 1978

NOPR - Notice of Proposed Rulemaking

NO<sub>x</sub> - Nitrogen Oxides - A series of air pollutants formed during combustion.

NPV - Net Present Value - A capital-budgeting method that accounts for the time value of money through discounted-cash-flow analysis. The method determines the present value of the expected net revenue from an investment minus the cost outlay, discounted at the cost of capital.

NSPS - New Source Performance Standards

O&M - Operation and Maintenance

ORA - Omnibus Reconciliation Act of 1981

ORC - Organic Rankine Cycle - Rankine cycle using an organic compound as the working fluid.

Parallel Generation - Industrial power generation facilities whose AC frequencies are exactly equal to and are synchronized with the utility service grid.

Payback Period - The number of years required for a firm to recover its original investment from net cash inflows.

Peak Load - The maximum load demand occurring during a specified period of time.

Peak-Load Management - An attempt to reduce the system peak load by leveling the load curve.

Power Factor - The ratio of real power to apparent power for any given load and time. Generally, it is expressed as a ratio.

Prime Mover - Equipment that transforms pressure or thermal energy to useful mechanical energy.

Process Heat - Heat used for an industrial process in a plant, and not for space heating.

Process Steam Load - Number of pounds of steam per hour required for a specified industrial process.

PSD - Prevention of Significant Deterioration

PURPA - Public Utility Regulatory Policies Act of 1978

PV - Present Value - The amount of money, which, if invested today at a certain rate of return, would be equivalent to a fixed amount to be received at a specified future time.

Rankine Cycle - A reversible thermodynamic cycle that describes the heat-to-work conversion process in a steam power plant.

Rate Base - The value of assets, established by a regulatory authority, on which a utility is permitted to earn a specified rate of return. Generally, this represents the amount of property used in public service.

RCRA - Resource Conservation and Recovery Act

ROI - Return on Investment

SCF - Standard cubic feet of gas at a temperature of 60°F and atmospheric pressure.

Shaft Power - Mechanical energy in the form of a rotating shaft.

Significant Emission Level - An emission rate (tons/year) for a specific number of pollutants above which the pollution level is considered significant for regulatory purposes.

SL - Straight-line depreciation

SO<sub>2</sub> - Sulfur Dioxide - A major pollutant formed by combustion of oil or coal.

Spinning Reserve - Generating capacity that is on-line and ready to take load, but in excess of the current load on the system.

Standby Service - Also Standby Power or Standby Reserve - Service that is not normally used but that is available through a permanent connection in lieu of, or as a supplement to, the usual source of supply.

Steam Turbine - A prime mover that converts the heat energy of steam, generated in a boiler, to mechanical energy.

Sunk Costs - Costs that have already been committed and, thus, are irrelevant to future investment decisions.

Surplus Electricity - Electricity generated beyond the immediate needs of the producing system, frequently obtained from spinning reserve and sold on an interruptible basis.

SYD - Sum-of-the-years'-digits depreciation

Payback Period - The number of years required for a firm to recover its original investment from net cash inflows.

Peak Load - The maximum load demand occurring during a specified period of time.

Peak-Load Management - An attempt to reduce the system peak load by leveling the load curve.

Power Factor - The ratio of real power to apparent power for any given load and time. Generally, it is expressed as a ratio.

Prime Mover - Equipment that transforms pressure or thermal energy to useful mechanical energy.

Process Heat - Heat used for an industrial process in a plant, and not for space heating.

Process Steam Load - Number of pounds of steam per hour required for a specified industrial process.

PSD - Prevention of Significant Deterioration

PURPA - Public Utility Regulatory Policies Act of 1978

PV - Present Value - The amount of money, which, if invested today at a certain rate of return, would be equivalent to a fixed amount to be received at a specified future time.

Rankine Cycle - A reversible thermodynamic cycle that describes the heat-to-work conversion process in a steam power plant.

Rate Base - The value of assets, established by a regulatory authority, on which a utility is permitted to earn a specified rate of return. Generally, this represents the amount of property used in public service.

RCRA - Resource Conservation and Recovery Act

ROI - Return on Investment

SCF - Standard cubic feet of gas at a temperature of 60°F and atmospheric pressure.

Shaft Power - Mechanical energy in the form of a rotating shaft.

Significant Emission Level - An emission rate (tons/year) for a specific number of pollutants above which the pollution level is considered significant for regulatory purposes.

SL - Straight-line depreciation

SO<sub>2</sub> - Sulfur Dioxide - A major pollutant formed by combustion of oil or coal.

Spinning Reserve - Generating capacity that is on-line and ready to take load, but in excess of the current load on the system.

Standby Service - Also Standby Power or Standby Reserve - Service that is not normally used but that is available through a permanent connection in lieu of, or as a supplement to, the usual source of supply.

Steam Turbine - A prime mover that converts the heat energy of steam, generated in a boiler, to mechanical energy.

Sunk Costs - Costs that have already been committed and, thus, are irrelevant to future investment decisions.

Surplus Electricity - Electricity generated beyond the immediate needs of the producing system, frequently obtained from spinning reserve and sold on an interruptible basis.

SYD - Sum-of-the-years'-digits depreciation

Topping Cycle - Energy is first used to generate electricity then used in an industrial process.

Total Energy System - Onsite generation of electricity with beneficial use of waste heat.

Turbine - An enclosed rotary type of prime mover in which the heat energy in steam or gas is converted into mechanical energy by the force of a high-velocity flow directed against successive rows of radial blades fastened to a central shaft.

Utility Cogeneration - Use of waste heat from a central power generation plant for space or process heat.

Waste Heat - Unused thermal energy that is exhausted to the environment from an electric generation system or an industrial process.

Waste-Heat Boiler - Hot exhaust gases from turbines, incinerators, furnace exhausts, and so on are used to generate steam.

Wheeling - The use of the transmission facilities of one system to transmit power to another system.

## APPENDIX A

### TEXTILE INDUSTRY PROFILE

The textile industry produces a wide variety of products from both natural and synthetic fibers. These products include knit and woven fabrics, rugs and carpets, and thread and yarn. In 1977, there were 7202 textile mills in the United States <sup>(1)</sup>. The industry is primarily concentrated in the Southeast, particularly in North and South Carolina, and Georgia.

Textile plants range from highly integrated mills that process fibers into finished products to smaller, nonintegrated plants that process goods owned by other producers on a contract basis. The Department of Commerce classifies the textile industry according to the Standard Industrial Classification (SIC), as shown in Table A.1. Knitting mills constitute the largest group within the industry with 2617 plants. The various types of weaving mills rank second with 1263 plants.

In 1977, the textile industry employed about 876,000 workers, which accounted for almost 5% of the U.S. manufacturing work force <sup>(2)</sup>. The textile industry is more labor intensive than most manufacturing industries. About 87% of the employed labor force consists of production workers, compared to a manufacturing industry average of about 70%.

#### FUNDAMENTAL OPERATIONS

Textile production consists of two basic operations: (1) the production of undyed, unfinished (greige) goods and (2) the production of finished goods from greige goods. Figure A.1 shows typical processing steps for knit and woven greige goods mills. These front-end operations are essentially dry operations, with the exception of slashing and subsequent drying.

Finishing operations (dyeing and finishing) transform the greige goods into finished fabric. Figure A.2 shows the processing steps in a typical finishing plant. Many of the finishing steps are wet operations that use water heated by direct steam injection. Drying operations use direct-fired natural gas or indirect steam heating of drying cylinders. <sup>(2)</sup>

#### ENERGY USE

Within the textile industry, textile finishing (SIC 226) is the largest user of purchased energy. Energy consumption for 1980 by SIC number is shown in Table A.2.

TABLE A.1. Textile Mill Industry Classification<sup>(1)</sup>

<u>SIC Number</u>	<u>Description</u>	<u>Establishments</u>
22	Textile Mill Products	7202
2211	Weaving Mills, Cotton	314
2221	Weaving Mills, Manmade Fiber, Silk	449
2231	Weaving and Finishing Mills, Wool	165
2241	Narrow Fabric Mills	335
225	Knitting Mills	2617
226	Textile Finishing, Except Wool	678
227	Floor Covering Mills	592
228	Yarn and Thread Mills	798
229	Miscellaneous Textile Goods	1254

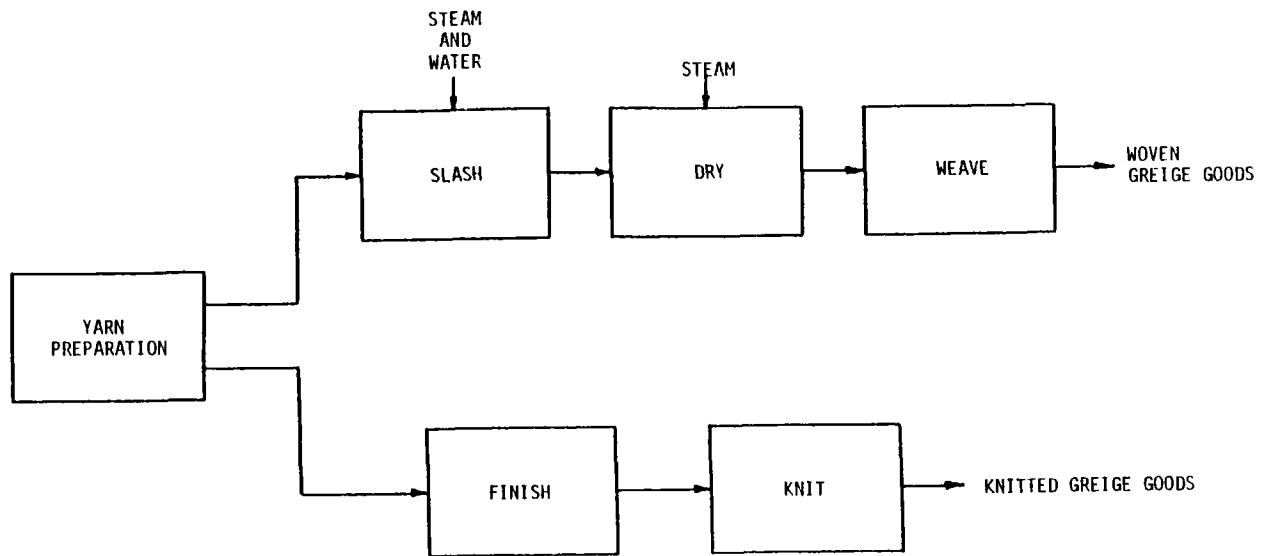

FIGURE A.1. Greige Goods Production<sup>(2)</sup>

Two-thirds of the energy consumed in textile manufacture is used in fabric finishing.<sup>(3)</sup> Most of the energy is used to raise steam, which is used for water heating or drying. Between 50 to 70% of the fossil energy used in the textile industry is for steam production.<sup>(4)</sup> Direct firing of natural gas for drying operations is the second largest consumer of energy, accounting for almost 25% of total energy use. The major heat transfer operations in a textile mill are listed in Table A.3.

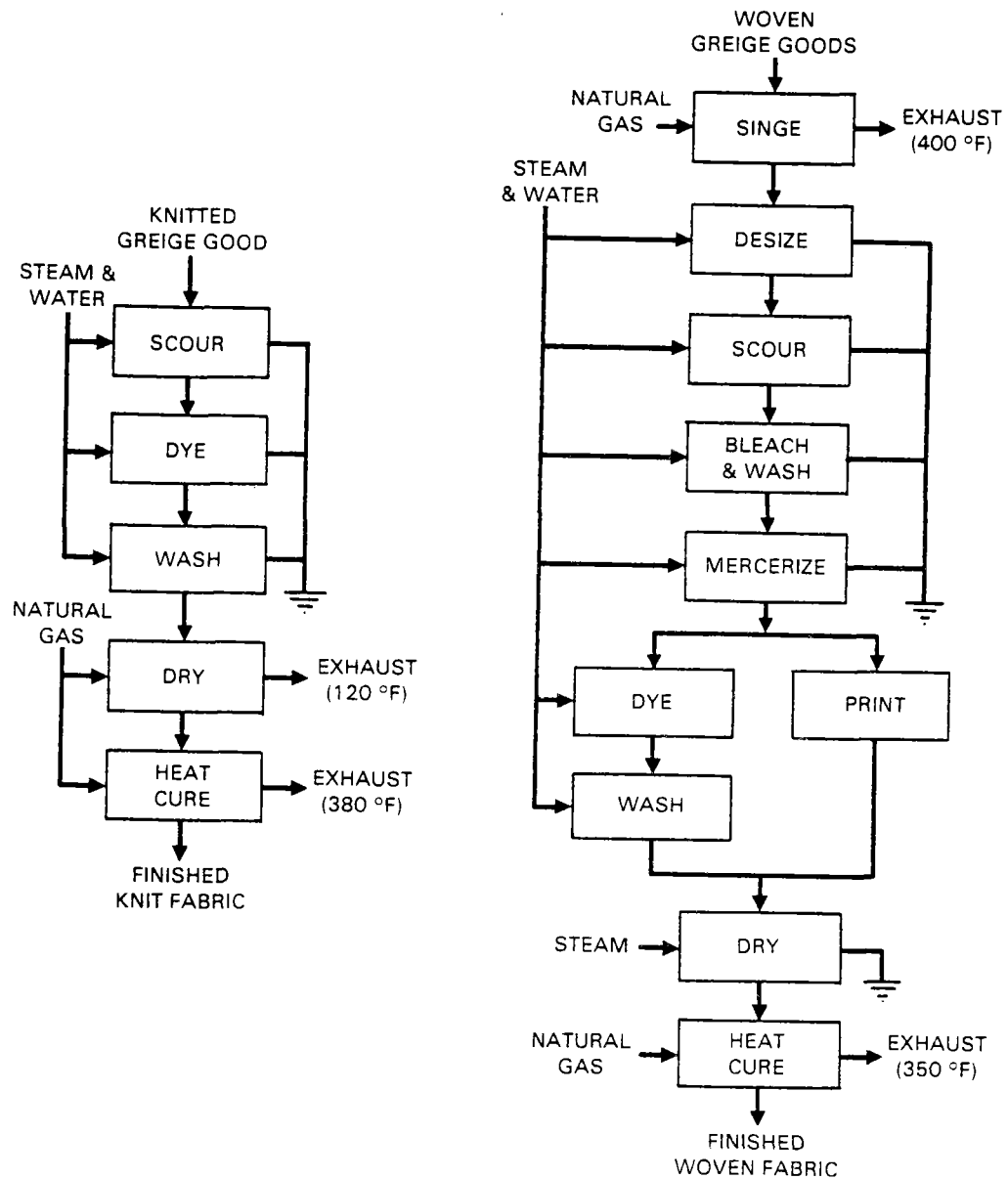

FIGURE A.2. Finishing Operations



TABLE A.2. Textile Industry Energy Use (1980)<sup>(2)</sup>

<u>SIC Number</u>	<u>Industry Category</u>	<u>Energy Use (10<sup>6</sup> Btu)</u>
2211	Weaving Mills, Cotton	35.9
2221	Weaving Mills, Manmade Fiber, Silk	44.9
2231	Weaving and Finishing Mills, Wool	4.9
2241	Narrow Fabric Mills	3.7
225	Knitting Mills	52.8
226	Textile Finishing, Except Wool	65.4
227	Floor Covering Mills	27.9
228	Yarn and Thread Mills	35.5
229	Miscellaneous Textile Goods	<u>23.9</u>
	Total	294.9

TABLE A.3. Major Energy-Using Operations

<u>Operation</u>	<u>Fuel or Heat Transfer Medium</u>
Steam Generation	Coal, Fuel Oil, or Natural Gas
Drying	Steam or Natural Gas
Singeing	Natural Gas
Water Heating	Steam

REFERENCES

1. Census of Manufacturers. 1977. Industry Statistics, Volume II, Part 1. U.S. Department of Commerce, Washington, D.C.
2. Cooper, Sidney. 1978. The Textile Industry: Environmental Control and Energy Conservation. Noyes Data Corporation, Park Ridge, New Jersey.
3. Streb, A. J. 1977. Priority Listing of Industrial Processes by Total Energy Consumption and Potential for Savings. CONS/5015-1. Prepared for the U.S. Department of Energy, Washington, D.C.
4. U.S. Department of Energy. 1982. Energy Conservation in the Textile Industry: 10 Case Histories. PNL-4363. Washington, D.C.
5. U.S. Department of Commerce. 1980. Annual Survey of Manufacturers: Fuels and Electric Energy Consumed. U.S. Government Printing Office, Washington, D.C.

APPENDIX B

TYPICAL HEATING VALUES OF COMMONLY USED FUELS

APPENDIX B

TYPICAL HEATING VALUES OF COMMONLY-USED FUELS

FUEL OIL

<u>Grade</u>	<u>Btu/Gallon</u>
No. 1	137,000-132,900
No. 2	141,800-137,000
No. 4	148,100-143,100
No. 5 (light)	150,000-146,800
No. 5 (heavy)	152,000-149,400
No. 6	155,900-151,300

GASES

	<u>Btu/ft<sup>3</sup></u>
Natural Gas	1047-1210
Mixed Refinery Gas	1380-1828
Oil Gas	540-700
Coal Gas	540-700
Coke-Oven Gas	550-650

COAL

<u>Class</u>	<u>Group</u>	<u>Btu/lb</u>
Anthracitic	Meta-anthracite	11,500
	Anthracite	14,300
	Semianthracite	15,000
Bituminous	Low-volatile bituminous	15,200
	Medium-volatile bituminous	15,200
	High-volatile A bituminous	14,800

APPENDIX B (Continued)

<u>Class</u>	<u>Group</u>	<u>Btu/lb</u>
Bituminous	High-volatile B bituminous	13,100
	High-volatile C bituminous	12,000
Subbituminous	Subbituminous A	11,000
	Subbituminous B	10,000
	Subbituminous C	9,200
Lignitic	Lignite A	7,400
	Lignite B	7,400

WASTE

<u>Type of Waste</u>	<u>Btu/lb</u>
Paper	7,572
Wood	8,613
Rags	7,652
Garbage	8,484
Coated Fabric - Rubber	10,996
Coated Felt - Vinyl	11,054
Coated Fabric - Vinyl	8,899
Polyethylene Film	19,161
Foam - Scrap	12,283
Tape - Resin-Covered Glass	7,907
Fabric - Nylon	13,202
Vinyl Scrap	11,428

APPENDIX C

STEAM PROPERTIES

Note: The following steam tables and Fig. 1 have been abstracted from *Thermodynamic and Transport Properties of Steam* (Copyright, 1967, by The American Society of Mechanical Engineers.)

**Table 1**  
Properties of saturated steam and saturated water (temperature)

Temp F	Press. psia	Volume, ft <sup>3</sup> /lb			Enthalpy, Btu/lb			Entropy, Btu/lb x F			Temp F
		Water <i>v<sub>f</sub></i>	Evap <i>v<sub>fg</sub></i>	Steam <i>v<sub>g</sub></i>	Water <i>h<sub>f</sub></i>	Evap <i>h<sub>fg</sub></i>	Steam <i>h<sub>g</sub></i>	Water <i>s<sub>f</sub></i>	Evap <i>s<sub>fg</sub></i>	Steam <i>s<sub>g</sub></i>	
32	0.08859	0.01602	3305	3305	-0.02	1075.5	1075.5	0.0000	2.1873	2.1873	32
35	0.09991	0.01602	2948	2948	3.00	1073.8	1076.8	0.0061	2.1706	2.1767	35
40	0.12163	0.01602	2446	2446	8.03	1071.0	1079.0	0.0162	2.1432	2.1594	40
45	0.14744	0.01602	2037.7	2037.8	13.04	1068.1	1081.2	0.0262	2.1164	2.1426	45
50	0.17796	0.01602	1704.8	1704.8	18.05	1065.3	1083.4	0.0361	2.0901	2.1262	50
60	0.2561	0.01603	1207.6	1207.6	28.06	1059.7	1087.7	0.0555	2.0391	2.0946	60
70	0.3629	0.01605	868.3	868.4	38.05	1054.0	1092.1	0.0745	1.9900	2.0645	70
80	0.5068	0.01607	633.3	633.3	48.04	1048.4	1096.4	0.0932	1.9426	2.0359	80
90	0.6981	0.01610	468.1	468.1	58.02	1042.7	1100.8	0.1115	1.8970	2.0086	90
100	0.9492	0.01613	350.4	350.4	68.00	1037.1	1105.1	0.1295	1.8530	1.9825	100
110	1.2750	0.01617	265.4	265.4	77.98	1031.4	1109.3	0.1472	1.8105	1.9577	110
120	1.6927	0.01620	203.25	203.26	87.97	1025.6	1113.6	0.1646	1.7693	1.9339	120
130	2.2230	0.01625	157.32	157.33	97.96	1019.8	1117.8	0.1817	1.7295	1.9112	130
140	2.8892	0.01629	122.98	123.00	107.95	1014.0	1122.0	0.1985	1.6910	1.8895	140
150	3.718	0.01634	97.05	97.07	117.95	1008.2	1126.1	0.2150	1.6536	1.8686	150
160	4.741	0.01640	77.27	77.29	127.96	1002.2	1130.2	0.2313	1.6174	1.8487	160
170	5.993	0.01645	62.04	62.06	137.97	996.2	1134.2	0.2473	1.5822	1.8295	170
180	7.511	0.01651	50.21	50.22	148.00	990.2	1138.2	0.2631	1.5480	1.8111	180
190	9.340	0.01657	40.94	40.96	158.04	984.1	1142.1	0.2787	1.5148	1.7934	190
200	11.526	0.01664	33.62	33.64	168.09	977.9	1146.0	0.2940	1.4824	1.7764	200
210	14.123	0.01671	27.80	27.82	178.15	971.6	1149.7	0.3091	1.4509	1.7600	210
212	14.696	0.01672	26.78	26.80	180.17	970.3	1150.5	0.3121	1.4447	1.7568	212
220	17.186	0.01678	23.13	23.15	188.23	965.2	1153.4	0.3241	1.4201	1.7442	220
230	20.779	0.01685	19.364	19.381	198.33	958.7	1157.1	0.3388	1.3902	1.7290	230
240	24.968	0.01693	16.304	16.321	208.45	952.1	1160.6	0.3533	1.3609	1.7142	240
250	29.825	0.01701	13.802	13.819	218.59	945.4	1164.0	0.3677	1.3323	1.7000	250
260	35.427	0.01709	11.745	11.762	228.76	938.6	1167.4	0.3819	1.3043	1.6862	260
270	41.856	0.01718	10.042	10.060	238.95	931.7	1170.6	0.3960	1.2769	1.6729	270
280	49.200	0.01726	8.627	8.644	249.17	924.6	1173.8	0.4098	1.2501	1.6599	280
290	57.550	0.01736	7.443	7.460	259.4	917.4	1176.8	0.4236	1.2238	1.6473	290
300	67.005	0.01745	6.448	6.466	269.7	910.0	1179.7	0.4372	1.1979	1.6351	300
310	77.67	0.01755	5.609	5.626	280.0	902.5	1182.5	0.4506	1.1726	1.6232	310
320	89.64	0.01766	4.896	4.914	290.4	894.8	1185.2	0.4640	1.1477	1.6116	320
340	117.99	0.01787	3.770	3.788	311.3	878.8	1190.1	0.4902	1.0990	1.5892	340
360	153.01	0.01811	2.939	2.957	332.3	862.1	1194.4	0.5161	1.0517	1.5678	360
380	195.73	0.01836	2.317	2.335	353.6	844.5	1198.0	0.5416	1.0057	1.5473	380
400	247.26	0.01864	1.8444	1.8630	375.1	825.9	1201.0	0.5667	0.9607	1.5274	400
420	308.78	0.01894	1.4808	1.4997	396.9	806.2	1203.1	0.5915	0.9165	1.5080	420
440	381.54	0.01926	1.1976	1.2169	419.0	785.4	1204.4	0.6161	0.8729	1.4890	440
460	466.9	0.0196	0.9746	0.9942	441.5	763.2	1204.8	0.6405	0.8299	1.4704	460
480	566.2	0.0200	0.7972	0.8172	464.5	739.6	1204.1	0.6648	0.7871	1.4518	480
500	680.9	0.0204	0.6545	0.6749	487.9	714.3	1202.2	0.6890	0.7443	1.4333	500
520	812.5	0.0209	0.5386	0.5596	512.0	687.0	1199.0	0.7133	0.7013	1.4146	520
540	962.8	0.0215	0.4437	0.4651	536.8	657.5	1194.3	0.7378	0.6577	1.3954	540
560	1133.4	0.0221	0.3651	0.3871	562.4	625.3	1187.7	0.7625	0.6132	1.3757	560
580	1326.2	0.0228	0.2994	0.3222	589.1	589.9	1179.0	0.7876	0.5673	1.3550	580
600	1543.2	0.0236	0.2438	0.2675	617.1	550.6	1167.7	0.8134	0.5196	1.3330	600
620	1786.9	0.0247	0.1962	0.2208	646.9	506.3	1153.2	0.8403	0.4689	1.3092	620
640	2059.9	0.0260	0.1543	0.1802	679.1	454.6	1133.7	0.8686	0.4134	1.2821	640
660	2365.7	0.0277	0.1166	0.1443	714.9	392.1	1107.0	0.8995	0.3502	1.2498	660
680	2708.6	0.0304	0.0808	0.1112	758.5	310.1	1068.5	0.9365	0.2720	1.2086	680
700	3094.3	0.0366	0.0386	0.0752	822.4	172.7	995.2	0.9901	0.1490	1.1390	700
705.5	3208.2	0.0508	0	0.0508	906.0	0	906.0	1.0612	0	1.0612	705.5

Source : Babcock & Wilcox, 1972. Steam / Its Generation and Use.

**Table 2**  
**Properties of saturated steam and saturated water (pressure)**

Press. psia	Temp F	Volume, ft <sup>3</sup> /lb			Enthalpy, Btu/lb			Entropy, Btu/lb x F			Energy, Btu/lb		Press. psia
		Water	Evap	Steam	Water	Evap	Steam	Water	Evap	Steam	Water	Steam	
		$v_f$	$v_{fg}$	$v_g$	$h_f$	$h_{fg}$	$h_g$	$s_f$	$s_{fg}$	$s_g$	$u_f$	$u_g$	
0.0886	32.018	0.01602	3302.4	3302.4	0.00	1075.5	1075.5	0	2.1872	2.1872	0	1021.3	0.0886
0.10	35.023	0.01602	2945.5	2945.5	3.03	1073.8	1076.8	0.0061	2.1705	2.1766	3.03	1022.3	0.10
0.15	45.453	0.01602	2004.7	2004.7	13.50	1067.9	1081.4	0.0271	2.1140	2.1411	13.50	1025.7	0.15
0.20	53.160	0.01603	1526.3	1526.3	21.22	1063.5	1084.7	0.0422	2.0738	2.1160	21.22	1028.3	0.20
0.30	64.484	0.01604	1039.7	1039.7	32.54	1057.1	1089.7	0.0641	2.0168	2.0809	32.54	1032.0	0.30
0.40	72.869	0.01606	792.0	792.1	40.92	1052.4	1093.3	0.0799	1.9762	2.0562	40.92	1034.7	0.40
0.5	79.586	0.01607	641.5	641.5	47.62	1048.6	1096.3	0.0925	1.9446	2.0370	47.62	1036.9	0.5
0.6	85.218	0.01609	540.0	540.1	53.25	1045.5	1098.7	0.1028	1.9186	2.0215	53.24	1038.7	0.6
0.7	90.09	0.01610	466.93	466.94	58.10	1042.7	1100.8	0.3	1.8966	2.0083	58.10	1040.3	0.7
0.8	94.38	0.01611	411.67	411.69	62.39	1040.3	1102.6	0.1117	1.8775	1.9970	62.39	1041.7	0.8
0.9	98.24	0.01612	368.41	368.43	66.24	1038.1	1104.3	0.1264	1.8606	1.9870	66.24	1042.9	0.9
1.0	101.74	0.01614	333.59	333.60	69.73	1036.1	1105.8	0.1326	1.8455	1.9781	69.73	1044.1	1.0
2.0	126.07	0.01623	173.74	173.76	94.03	1022.1	1116.2	0.1750	1.7450	1.9200	94.03	1051.8	2.0
3.0	141.47	0.01630	118.71	118.73	109.42	1013.2	1122.6	0.2009	1.6854	1.8864	109.41	1056.7	3.0
4.0	152.96	0.01636	90.63	90.64	120.92	1006.4	1127.3	0.2199	1.6428	1.8626	120.90	1060.2	4.0
5.0	162.24	0.01641	73.515	73.53	130.20	1000.9	1131.1	0.2349	1.6094	1.8443	130.18	1063.1	5.0
6.0	170.05	0.01645	61.967	61.98	138.03	996.2	1134.2	0.2474	1.5820	1.8294	138.01	1065.4	6.0
7.0	176.84	0.01649	53.634	53.65	144.83	992.1	1136.9	0.2581	1.5587	1.8168	144.81	1067.4	7.0
8.0	182.86	0.01653	47.328	47.35	150.87	988.5	1139.3	0.2676	1.5384	1.8060	150.84	1069.2	8.0
9.0	188.27	0.01656	42.385	42.40	156.30	985.1	1141.4	0.2760	1.5204	1.7964	156.28	1070.8	9.0
10	193.21	0.01659	38.404	38.42	161.26	982.1	1143.3	0.2836	1.5043	1.7879	161.23	1072.3	10
14.696	212.00	0.01672	26.782	26.80	180.17	970.3	1150.5	0.3121	1.4447	1.7568	180.12	1077.6	14.696
15	213.03	0.01673	26.274	26.29	181.21	969.7	1150.9	0.3137	1.4415	1.7552	181.16	1077.9	15
20	227.96	0.01683	20.070	20.087	196.27	960.1	1156.3	0.3358	1.3962	1.7320	196.21	1082.0	20
30	250.34	0.01701	13.7266	13.744	218.9	945.2	1164.1	0.3682	1.3313	1.6995	218.8	1087.9	30
40	267.25	0.01715	10.4794	10.497	236.1	933.6	1169.8	0.3921	1.2844	1.6765	236.0	1092.1	40
50	281.02	0.01727	8.4967	8.514	250.2	923.9	1174.1	0.4112	1.2474	1.6586	250.1	1095.3	50
60	292.71	0.01738	7.1562	7.174	262.2	915.4	1177.6	0.4273	1.2167	1.6440	262.0	1098.0	60
70	302.93	0.01748	6.1875	6.205	272.7	907.8	1180.6	0.4411	1.1905	1.6316	272.5	1100.2	70
80	312.04	0.01757	5.4536	5.471	282.1	900.9	1183.1	0.4534	1.1675	1.6208	281.9	1102.1	80
90	320.28	0.01766	4.8777	4.895	290.7	894.6	1185.3	0.4643	1.1470	1.6113	290.4	1103.7	90
100	327.82	0.01774	4.4133	4.431	298.5	888.6	1187.2	0.4743	1.1284	1.6027	298.2	1105.2	100
120	341.27	0.01789	3.7097	3.728	312.6	877.8	1190.4	0.4919	1.0960	1.5879	312.2	1107.6	120
140	353.04	0.01803	3.2010	3.219	325.0	868.0	1193.0	0.5071	1.0681	1.5752	324.5	1109.6	140
160	363.55	0.01815	2.8155	2.834	336.1	859.0	1195.1	0.5206	1.0435	1.5641	335.5	1111.2	160
180	373.08	0.01827	2.5129	2.531	346.2	850.7	1196.9	0.5328	1.0215	1.5543	345.6	1112.5	180
200	381.80	0.01839	2.2689	2.287	355.5	842.8	1198.3	0.5438	1.0016	1.5454	354.8	1113.7	200
250	400.97	0.01865	1.8245	1.8432	376.1	825.0	1201.1	0.5679	0.9585	1.5264	375.3	1115.8	250
300	417.35	0.01889	1.5238	1.5427	394.0	808.9	1202.9	0.5882	0.9223	1.5105	392.9	1117.2	300
350	431.73	0.01913	1.3064	1.3255	409.8	794.2	1204.0	0.6059	0.8909	1.4968	408.6	1118.1	350
400	444.60	0.0193	1.14162	1.1610	424.2	780.4	1204.6	0.6217	0.8630	1.4847	422.7	1118.7	400
450	456.28	0.0195	1.01224	1.0318	437.3	767.5	1204.8	0.6360	0.8378	1.4738	435.7	1118.9	450
500	467.01	0.0198	0.90787	0.9276	449.5	755.1	1204.7	0.6490	0.8148	1.4639	447.7	1118.8	500
550	476.94	0.0199	0.82183	0.8418	460.9	743.3	1204.3	0.6611	0.7936	1.4547	458.9	1118.6	550
600	486.20	0.0201	0.74962	0.7698	471.7	732.0	1203.7	0.6723	0.7738	1.4461	469.5	1118.2	600
700	503.08	0.0205	0.63505	0.6556	491.6	710.2	1201.8	0.6928	0.7377	1.4304	488.9	1116.9	700
800	518.21	0.0209	0.54809	0.5690	509.8	689.6	1199.4	0.7111	0.7051	1.4163	506.7	1115.2	800
900	531.95	0.0212	0.47968	0.5009	526.7	669.7	1196.4	0.7279	0.6753	1.4032	523.2	1113.0	900
1000	544.58	0.0216	0.42436	0.4460	542.6	650.4	1192.9	0.7434	0.6476	1.3910	538.6	1110.4	1000
1100	556.28	0.0220	0.37863	0.4006	557.5	631.5	1189.1	0.7578	0.6216	1.3794	553.1	1107.5	1100
1200	567.19	0.0223	0.34013	0.3625	571.9	613.0	1184.8	0.7714	0.5969	1.3683	566.9	1104.3	1200
1300	577.42	0.0227	0.30722	0.3299	585.6	594.6	1180.2	0.7843	0.5733	1.3577	580.1	1100.9	1300
1400	587.07	0.0231	0.27871	0.3018	598.8	576.5	1175.3	0.7966	0.5507	1.3474	592.9	1097.1	1400
1500	596.20	0.0235	0.25372	0.2772	611.7	558.4	1170.1	0.8085	0.5288	1.3373	605.2	1093.1	1500
2000	635.80	0.0257	0.16266	0.1883	672.1	466.2	1138.3	0.8625	0.4256	1.2881	662.6	1068.6	2000
2500	668.11	0.0286	0.10209	0.1307	731.7	361.6	1093.3	0.9139	0.3206	1.2345	718.5	1032.9	2500
3000	695.33	0.0343	0.05073	0.0850	801.8	218.4	1020.3	0.9728	0.1891	1.1619	782.8	973.1	3000
3208.2	705.47	0.0508	0	0.0508	906.0	0	906.0	1.0612	0	1.0612	875.9	875.9	3208.2

**Table 3**  
**Properties of superheated steam and compressed water (temperature and pressure)**

Abs. press. lb/sq in. (sat. temp)	Temperature, F														
	100	200	300	400	500	600	700	800	900	1000	1100	1200	1300	1400	1500
1 v (101.74)	0.0161	392.5	452.3	511.9	571.5	631.1	690.7								
h	68.00	1150.2	1195.7	1241.8	1288.2	1335.9	1384.3	1433.6	1483.7	1534.7	1586.7	1639.6	1693.3	1748.0	1803.5
s	0.1295	2.0509	2.1152	2.1722	2.2237	2.2708	2.3144								
5 v (162.24)	0.0161	78.14	90.24	102.24	114.21	126.15	138.08	150.01	161.94	173.86	185.78	197.70	209.62	221.53	233.45
h	68.01	1148.6	1194.8	1241.3	1288.2	1335.9	1384.3	1433.6	1483.7	1534.7	1586.7	1639.6	1693.3	1748.0	1803.5
s	0.1295	1.8716	1.9369	1.9943	2.0460	2.0932	2.1369	2.1776	2.2159	2.2521	2.2866	2.3194	2.3509	2.3811	2.4101
10 v (193.21)	0.0161	38.84	44.98	51.03	57.04	63.03	69.00	74.98	80.94	86.91	92.87	98.84	104.80	110.76	116.72
h	68.02	1146.6	1193.7	1240.6	1287.8	1335.5	1384.0	1433.2	1483.4	1534.5	1586.5	1639.4	1693.2	1747.8	1803.4
s	0.1295	1.7928	1.8593	1.9173	1.9692	2.0166	2.0603	2.1011	2.1394	2.1757	2.2101	2.2430	2.2744	2.3046	2.3337
15 v (213.03)	0.0161	0.0166	29.899	33.963	37.985	41.986	45.978	49.964	53.946	57.926	61.905	65.882	69.858	73.833	77.807
h	68.04	168.09	1192.5	1239.9	1287.3	1335.2	1383.8	1433.2	1483.4	1534.5	1586.5	1639.4	1693.2	1747.8	1803.4
s	0.1295	0.2940	1.8134	1.8720	1.9242	1.9717	2.0155	2.0563	2.0946	2.1309	2.1653	2.1982	2.2297	2.2599	2.2890
20 v (227.96)	0.0161	0.0166	22.356	25.428	28.457	31.466	34.465	37.458	40.447	43.435	46.420	49.405	52.388	55.370	58.352
h	68.05	168.11	1191.4	1239.2	1286.9	1334.9	1383.5	1432.9	1483.2	1534.3	1586.3	1639.2	1693.1	1747.7	1803.3
s	0.1295	0.2940	1.7805	1.8397	1.8921	1.9397	1.9836	2.0244	2.0628	2.0991	2.1336	2.1665	2.1979	2.2282	2.2572
40 v (267.25)	0.0161	0.0166	11.036	12.624	14.165	15.685	17.195	18.699	20.199	21.697	23.194	24.689	26.183	27.676	29.168
h	68.10	168.15	1186.6	1236.4	1285.0	1333.6	1382.5	1432.1	1482.5	1533.7	1585.8	1638.8	1692.7	1747.5	1803.0
s	0.1295	0.2940	1.6992	1.7608	1.8143	1.8624	1.9065	1.9476	1.9860	2.0224	2.0569	2.0899	2.1224	2.1516	2.1807
60 v (292.71)	0.0161	0.0166	7.257	8.354	9.400	10.425	11.438	12.446	13.450	14.452	15.452	16.450	17.448	18.445	19.441
h	68.15	168.20	1181.6	1233.5	1283.2	1332.3	1381.5	1431.3	1481.8	1533.2	1585.3	1638.4	1692.4	1747.1	1802.8
s	0.1295	0.2939	1.6492	1.7134	1.7681	1.8168	1.8612	1.9024	1.9410	1.9774	2.0120	2.0450	2.0765	2.1068	2.1359
80 v (312.04)	0.0161	0.0166	0.0175	6.218	7.018	7.794	8.560	9.319	10.075	10.829	11.581	12.331	13.081	13.829	14.577
h	68.21	168.24	269.74	1230.5	1281.3	1330.9	1380.5	1430.5	1481.1	1532.6	1584.9	1638.0	1692.0	1746.8	1802.5
s	0.1295	0.2939	0.4371	1.6790	1.7349	1.7842	1.8289	1.8702	1.9089	1.9454	1.9800	2.0131	2.0446	2.0750	2.1041
100 v (327.82)	0.0161	0.0166	0.0175	4.935	5.588	6.216	6.833	7.443	8.050	8.655	9.258	9.860	10.460	11.060	11.659
h	68.26	168.29	269.77	1227.4	1279.3	1329.6	1379.5	1429.7	1480.4	1532.0	1584.4	1637.6	1691.6	1746.5	1802.2
s	0.1295	0.2939	0.4371	1.6516	1.7088	1.7586	1.8036	1.8451	1.8839	1.9205	1.9552	1.9883	2.0199	2.0502	2.0794
120 v (341.27)	0.0161	0.0166	0.0175	4.0786	4.6341	5.1637	5.6831	6.1928	6.7006	7.2060	7.7096	8.2119	8.7130	9.2134	9.7130
h	68.31	168.33	269.81	1224.1	1277.4	1328.1	1378.4	1428.8	1479.8	1531.4	1583.9	1637.1	1691.3	1746.2	1802.0
s	0.1295	0.2939	0.4371	1.6286	1.6872	1.7376	1.7829	1.8246	1.8635	1.9001	1.9349	1.9680	1.9996	2.0300	2.0592
140 v (353.04)	0.0161	0.0166	0.0175	3.4661	3.9526	4.4119	4.8585	5.2995	5.7364	6.1709	6.6036	7.0349	7.4652	7.8946	8.3233
h	68.37	168.38	269.85	1220.8	1275.3	1326.8	1377.4	1428.0	1479.1	1530.8	1583.4	1636.7	1690.9	1745.9	1801.7
s	0.1295	0.2939	0.4370	1.6085	1.6686	1.7196	1.7652	1.8071	1.8461	1.8828	1.9176	1.9508	1.9825	2.0129	2.0421
160 v (363.55)	0.0161	0.0166	0.0175	3.0060	3.4413	3.8480	4.2420	4.6295	5.0132	5.3945	5.7741	6.1522	6.5293	6.9055	7.2811
h	68.42	168.42	269.89	1217.4	1273.3	1325.4	1376.4	1427.2	1478.4	1530.3	1582.9	1636.3	1690.5	1745.6	1801.4
s	0.1294	0.2938	0.4370	1.5906	1.6522	1.7039	1.7499	1.7919	1.8310	1.8678	1.9027	1.9359	1.9676	1.9980	2.0273
180 v (373.08)	0.0161	0.0166	0.0174	2.6474	3.0433	3.4093	3.7621	4.1084	4.4505	4.7907	5.1289	5.4657	5.8014	6.1363	6.4704
h	68.47	168.47	269.92	1213.8	1271.2	1324.0	1375.3	1426.3	1477.7	1529.7	1582.4	1635.9	1690.2	1745.3	1801.2
s	0.1294	0.2938	0.4370	1.5743	1.6376	1.6900	1.7362	1.7784	1.8176	1.8545	1.8894	1.9227	1.9545	1.9849	2.0142
200 v (381.80)	0.0161	0.0166	0.0174	2.3598	2.7247	3.0583	3.3783	3.6915	4.0008	4.3077	4.6128	4.9165	5.2191	5.5209	5.8219
h	68.52	168.51	269.96	1210.1	1269.0	1322.6	1374.3	1425.5	1477.0	1529.1	1581.9	1635.4	1689.8	1745.0	1800.9
s	0.1294	0.2938	0.4369	1.5593	1.6242	1.6776	1.7239	1.7663	1.8057	1.8426	1.8776	1.9109	1.9427	1.9732	2.0025
250 v (400.97)	0.0161	0.0166	0.0174	0.0186	2.1504	2.4662	2.6872	2.9410	3.1909	3.4382	3.6837	3.9278	4.1709	4.4131	4.6546
h	68.66	168.63	270.05	375.10	1263.5	1319.0	1371.6	1423.4	1475.3	1527.6	1580.6	1634.4	1688.9	1744.2	1800.2
s	0.1294	0.2937	0.4368	0.5667	1.5951	1.6502	1.6976	1.7405	1.7801	1.8173	1.8524	1.8858	1.9177	1.9482	1.9776
300 v (417.35)	0.0161	0.0166	0.0174	0.0186	1.7665	2.0044	2.2263	2.4407	2.6509	2.8585	3.0643	3.2688	3.4721	3.6746	3.8764
h	68.79	168.74	270.14	375.15	1257.7	1315.2	1368.9	1421.3	1473.6	1526.2	1579.4	1633.3	1688.0	1743.4	1799.6
s	0.1294	0.2937	0.4307	0.5665	1.5703	1.6274	1.6758	1.7192	1.7591	1.7964	1.8317	1.8652	1.8972	1.9278	1.9572
350 v (431.73)	0.0161	0.0166	0.0174	0.0186	1.4913	1.7028	1.8970	2.0832	2.2652	2.4445	2.6219	2.7980	2.9730	3.1471	3.3205
h	68.92	168.85	270.24	375.21	1251.5	1311.4	1366.2	1419.2	1471.8	1524.7	1578.2	1632.3	1687.1	1742.6	1798.9
s	0.1293	0.2936	0.4367	0.5664	1.5483	1.6077	1.6571	1.7009	1.7411	1.7787	1.8141	1.8477	1.8798	1.9105	1.9400
400 v (444.60)	0.0161	0.0166	0.0174	0.0162	1.2841	1.4763	1.6499	1.8151	1.9759	2.1339	2.2901	2.4450	2.5987	2.7515	2.9037
h	69.05	168.97	270.33	375.27	1245.1	1307.4	1363.4	1417.0	1470.1	1523.3	1576.9	1631.2	1686.2	1741.9	1798.2
s	0.1293	0.2935	0.4366	0.5663	1.5282	1.5901	1.6406	1.6850	1.7255	1.7632	1.7988	1.8325	1.8647	1.8955	1.9250
500 v (467.01)	0.0161	0.0166	0.0174	0.0186	0.9919	1.1584	1.3037	1.4397	1.5708	1.6992	1.8256	1.9507	2.0746	2.1977	2.3200
h	69.32	169.19	270.51	375.38	1231.2	1299.1	1357.7	1412.7	1466.6	1520.3	1574.4	1629.1	1684.4	1740.3	1796.9
s	0.1292	0.2934	0.4364	0.5660	1.4921	1.5595	1.6123	1.6578	1.6990	1.7371	1.7730	1.8069	1.8393	1.8702	1.8998

**Table 3**  
**Properties of superheated steam and compressed water (temperature and pressure)**

Abs press. lb/sq in. (sat. temp)	Temperature, F															
	100	200	300	400	500	600	700	800	900	1000	1100	1200	1300	1400	1500	
600 (486.20)	v	0.0161	0.0166	0.0174	0.0186	0.7944	0.9456	1.0726	1.1892	1.3008	1.4093	1.5160	1.6211	1.7252	1.8284	1.9309
	h	69.58	169.42	270.70	375.49	1215.9	1290.3	1351.8	1408.3	1463.0	1517.4	1571.9	1627.0	1682.6	1738.8	1795.6
	s	0.1292	0.2933	0.4362	0.5657	1.4590	1.5329	1.5844	1.6351	1.6769	1.7155	1.7517	1.7859	1.8184	1.8494	1.8792
700 (503.08)	v	0.0161	0.0166	0.0174	0.0186	0.0204	0.7928	0.9072	1.0102	1.1078	1.2023	1.2948	1.3858	1.4757	1.5647	1.6530
	h	69.84	169.65	270.89	375.61	487.93	1281.0	1345.6	1403.7	1459.4	1514.4	1569.4	1624.8	1680.7	1737.2	1794.3
	s	0.1291	0.2932	0.4360	0.5655	0.6889	1.5090	1.5673	1.6154	1.6580	1.6970	1.7335	1.7679	1.8006	1.8318	1.8617
800 (518.21)	v	0.0161	0.0166	0.0174	0.0186	0.0204	0.6774	0.7828	0.8759	0.9631	1.0470	1.1289	1.2093	1.2885	1.3669	1.4446
	h	70.11	169.88	271.07	375.73	487.88	1271.1	1339.2	1399.1	1455.8	1511.4	1566.9	1622.7	1678.9	1735.0	1792.9
	s	0.1290	0.2930	0.4358	0.5652	0.6885	1.4869	1.5484	1.5980	1.6413	1.6807	1.7175	1.7522	1.7851	1.8164	1.8464
900 (531.95)	v	0.0161	0.0166	0.0174	0.0186	0.0204	0.5869	0.6858	0.7713	0.8504	0.9262	0.9998	1.0720	1.1430	1.2131	1.2825
	h	70.37	170.10	271.26	375.84	487.83	1260.6	1332.7	1394.4	1452.2	1508.5	1564.4	1620.6	1677.1	1734.1	1791.6
	s	0.1290	0.2929	0.4357	0.5649	0.6881	1.4659	1.5311	1.5822	1.6263	1.6662	1.7033	1.7382	1.7713	1.8028	1.8329
1000 (544.58)	v	0.0161	0.0166	0.0174	0.0186	0.0204	0.5137	0.6080	0.6875	0.7603	0.8295	0.8966	0.9622	1.0266	1.0901	1.1529
	h	70.63	170.33	271.44	375.96	487.79	1249.3	1325.9	1389.6	1448.5	1504.4	1561.9	1618.4	1675.3	1732.5	1790.3
	s	0.1289	0.2928	0.4355	0.5647	0.6876	1.4457	1.5149	1.5677	1.6126	1.6530	1.6905	1.7256	1.7589	1.7905	1.8207
1100 (556.28)	v	0.0161	0.0166	0.0174	0.0185	0.0203	0.4531	0.5440	0.6188	0.6865	0.7505	0.8121	0.8723	0.9313	0.9894	1.0468
	h	70.90	170.56	271.63	376.08	487.75	1237.3	1318.8	1384.7	1444.7	1502.4	1559.4	1616.3	1673.5	1731.0	1789.0
	s	0.1289	0.2927	0.4353	0.5644	0.6872	1.4259	1.4996	1.5542	1.6000	1.6410	1.6787	1.7141	1.7475	1.7793	1.8097
1200 (567.19)	v	0.0161	0.0166	0.0174	0.0185	0.0203	0.4016	0.4905	0.5615	0.6250	0.6845	0.7418	0.7974	0.8519	0.9055	0.9584
	h	71.16	170.78	271.82	376.20	487.72	1224.2	1311.5	1379.7	1440.9	1499.4	1556.9	1614.2	1671.6	1729.4	1787.6
	s	0.1288	0.2926	0.4351	0.5642	0.6868	1.4061	1.4851	1.5415	1.5883	1.6298	1.6679	1.7035	1.7371	1.7691	1.7996
1400 (587.07)	v	0.0161	0.0166	0.0174	0.0185	0.0203	0.3176	0.4059	0.4712	0.5282	0.5809	0.6311	0.6798	0.7272	0.7737	0.8195
	h	71.68	171.24	272.19	376.44	487.65	1194.1	1296.1	1369.3	1433.2	1493.2	1551.8	1609.9	1668.0	1726.3	1785.0
	s	0.1287	0.2923	0.4348	0.5636	0.6859	1.3652	1.4575	1.5182	1.5670	1.6096	1.6484	1.6845	1.7185	1.7508	1.7815
1600 (604.87)	v	0.0161	0.0166	0.0173	0.0185	0.0202	0.2315	0.3415	0.4032	0.4555	0.5031	0.5482	0.5915	0.6336	0.6748	0.7153
	h	72.21	171.69	272.57	376.69	487.60	1179.4	1279.4	1358.5	1425.2	1486.9	1546.6	1605.6	1664.3	1723.2	1782.3
	s	0.1286	0.2921	0.4344	0.5631	0.6851	1.3412	1.4312	1.4968	1.5478	1.5916	1.6312	1.6678	1.7022	1.7344	1.7657
1800 (621.02)	v	0.0160	0.0165	0.0173	0.0185	0.0202	0.2906	0.3500	0.3988	0.4426	0.4836	0.5229	0.5609	0.5980	0.6343	0.6703
	h	72.73	172.15	272.95	376.93	487.56	1261.1	1347.2	1417.1	1480.6	1541.1	1601.2	1660.7	1720.1	1779.7	1839.3
	s	0.1284	0.2918	0.4341	0.5626	0.6843	1.4054	1.4768	1.5302	1.5753	1.6156	1.6528	1.6876	1.7204	1.7516	1.7816
2000 (635.80)	v	0.0160	0.0165	0.0173	0.0184	0.0201	0.2488	0.3072	0.3534	0.3942	0.4320	0.4680	0.5027	0.5365	0.5695	0.6025
	h	73.26	172.60	273.32	377.19	487.53	1240.9	1353.4	1408.7	1474.1	1536.2	1596.9	1657.0	1717.0	1777.1	1837.1
	s	0.1283	0.2916	0.4337	0.5621	0.6834	1.3794	1.4578	1.5138	1.5603	1.6014	1.6391	1.6743	1.7075	1.7389	1.7693
2500 (668.11)	v	0.0160	0.0165	0.0173	0.0184	0.0200	0.1681	0.2293	0.2712	0.3068	0.3390	0.3692	0.3980	0.4259	0.4529	0.4799
	h	74.57	173.74	274.27	377.82	487.50	1176.7	1303.4	1386.7	1457.5	1522.9	1585.9	1647.8	1709.2	1770.4	1831.6
	s	0.1280	0.2910	0.4329	0.5609	0.6815	1.3076	1.4129	1.4766	1.5269	1.5703	1.6094	1.6456	1.6796	1.7116	1.7426
3000 (695.33)	v	0.0160	0.0165	0.0172	0.0183	0.0200	0.0982	0.1759	0.2161	0.2484	0.2770	0.3033	0.3282	0.3522	0.3753	0.3979
	h	75.88	174.88	275.22	378.47	487.52	1060.5	1267.0	1363.2	1440.2	1509.4	1574.8	1638.5	1701.4	1764.3	1827.2
	s	0.1277	0.2904	0.4320	0.5597	0.6796	1.1966	1.3692	1.4429	1.4976	1.5434	1.5841	1.6214	1.6561	1.6888	1.7206
3200 (705.08)	v	0.0160	0.0165	0.0172	0.0183	0.0199	0.0227	0.0335	0.1588	0.1987	0.2301	0.2576	0.2827	0.3065	0.3291	0.3510
	h	76.4	175.3	275.6	378.7	487.5	609.4	800.8	1250.9	1353.4	1433.1	1503.8	1570.3	1634.8	1698.3	1761.2
	s	0.1276	0.2902	0.4317	0.5592	0.6788	0.7994	0.9708	1.3515	1.4300	1.4866	1.5335	1.5749	1.6126	1.6477	1.6806
3500	v	0.0160	0.0164	0.0172	0.0183	0.0199	0.0225	0.0307	0.1364	0.1764	0.2066	0.2326	0.2563	0.2784	0.2995	0.3198
	h	77.2	176.0	276.2	379.1	487.6	608.4	779.4	1224.6	1338.2	1422.2	1495.5	1563.3	1629.2	1693.6	1757.2
	s	0.1274	0.2899	0.4312	0.5585	0.6777	0.7973	0.9508	1.3242	1.4112	1.4709	1.5194	1.5618	1.6002	1.6358	1.6691
4000	v	0.0159	0.0164	0.0172	0.0182	0.0198	0.0223	0.0287	0.1052	0.1463	0.1752	0.1994	0.2210	0.2411	0.2601	0.2783
	h	78.5	177.2	277.1	379.8	487.7	606.9	763.0	1174.3	1311.6	1403.6	1481.3	1552.2	1619.8	1685.7	1750.6
	s	0.1271	0.2893	0.4304	0.5573	0.6760	0.7940	0.9343	1.2754	1.3807	1.4461	1.4976	1.5417	1.5812	1.6177	1.6516
5000	v	0.0159	0.0164	0.0171	0.0181	0.0196	0.0219	0.0268	0.0591	0.1038	0.1312	0.1529	0.1718	0.1890	0.2050	0.2203
	h	81.1	179.5	279.1	381.2	488.1	604.6	746.0	1042.9	1252.9	1364.6	1452.1	1529.1	1600.9	1670.0	1737.4
	s	0.1265	0.2881	0.4287	0.5550	0.6726	0.7880	0.9153	1.1593	1.3207	1.4001	1.4582	1.5061	1.5481	1.5863	1.6216
6000	v	0.0159	0.0163	0.0170	0.0180	0.0195	0.0216	0.0256	0.0397	0.0757	0.1020	0.1221	0.1391	0.1544	0.1684	0.1817
	h	83.7	181.7	281.0	382.7	488.6	602.9	736.1	945.1	1188.8	1323.6	1422.3	1505.9	1582.0	1654.2	1724.2
	s	0.1258	0.2870	0.4271	0.5528	0.6693	0.7826	0.9026	1.0176	1.2615	1.3574	1.4229	1.4748	1.5194	1.5593	1.5962
7000	v	0.0158	0.0163	0.0170	0.0180	0.0193	0.0213	0.0248	0.0334	0.0573	0.0816	0.1004	0.1160	0.1298	0.1424	0.1542
	h	86.2	184.4	283.0	384.2	489.3	601.7	729.3	901.8	1124.9	1281.7	1392.2	1482.6	1563.1	1638.6	1711.1
	s	0.1252	0.2859	0.4256	0.5507	0.6663	0.7777	0.8926	1.0350	1.2055	1.3171	1.3904	1.4466	1.4938	1.5355	1.5735



APPENDIX D

ASSUMPTIONS USED TO DERIVE PERFORMANCE CURVES

## APPENDIX D

### ASSUMPTIONS USED TO DERIVE PERFORMANCE CURVES

#### FOR ALL CONFIGURATIONS

- Power conversion efficiency,  $\eta_c = .85$   
(this allows for generation and transmission losses, as well as the operation of auxiliaries)
- Condensate return conditions,  $T_2 = 170^\circ\text{F}$   
 $h_2 = 138 \text{ Btu/lb}$
- Deaerator at 5 psig ( $h_3 = 196 \text{ Btu/lb}$ )

#### STEAM TURBINE

- Boiler efficiency,  $\eta_b = .85$
- Turbine inlet conditions:  $T_o = 950^\circ\text{F}$   
 $p_o = 900 \text{ psig}$   
 $h_o = 1478 \text{ Btu/lb}$

#### GAS TURBINE

- Pinch-point temperature,  $T_g' - T_4 = 60^\circ\text{F}$
- Turbine exit temperature,  $T_g = 950^\circ\text{F}$
- Heat exchanger effectiveness,  $\eta_e = .95$
- Heat capacity of turbine exhaust,  $C_p = 0.27 \text{ Btu/lb}^\circ\text{F}$
- Conditions at state point 4: saturated at the steam sendout pressure  $p_1$

#### COMBINED CYCLE

- Gas turbine exit temperature,  $T_g = 950^\circ\text{F}$
- Heat exchanger effectiveness,  $\eta_e = .95$
- Heat capacity of turbine exhaust,  $C_p = 0.27 \text{ Btu/lb}^\circ\text{F}$
- Steam turbine inlet conditions:  $p_o = 900 \text{ psig}$   
 $T_o = 890^\circ\text{F}$   
 $h_o = 1446 \text{ Btu/lb}$
- Gas temperature at pinch point,  $T_g' = 594^\circ\text{F}$
- Water enthalpy at pinch point,  $h_4 = 529 \text{ Btu/lb}$

#### DIESEL

- Pinch-point temperature,  $T_g' - T_4 = 60^\circ\text{F}$
- Heat exchanger effectiveness,  $\eta_e = .95$
- Heat capacity of exhaust,  $C_p = 0.27 \text{ Btu/lb}^\circ\text{F}$
- Exhaust temperature,  $T_g = 855^\circ\text{F}$
- Air to fuel ratio,  $a/f = 0.58 \times \text{stoichiometric}$   
Stoichiometric air to fuel ratio = 0.0670
- Lower heating value heavy diesel fuel,  $HV = 17790 \text{ Btu/lb}$

### BOTTOMING CYCLE

- Heat exchanger effectiveness,  $e = .95$
- Heat capacity of exhaust gas,  $C_p = 0.27 \text{ Btu/lb}^\circ\text{F}$
- Gas temperature at pinch point,  $T_g' = 594^\circ\text{F}$
- Water enthalpy at pinch point,  $h_4 = 529 \text{ Btu/lb}$
- Steam temperature at turbine inlet,  $T_o = T_g - 60^\circ\text{F}$

APPENDIX E

BASIC ECONOMIC CONCEPTS AND TERMINOLOGY

## APPENDIX E

### BASIC ECONOMIC CONCEPTS AND TERMINOLOGY

This section describes a few basic concepts, such as the time value of money, discount rate, current and constant dollars, nominal and real interest rates, and tax credits. Proper understanding of these concepts is essential in reaching a correct investment decision.

#### TIME VALUE OF MONEY

Basic to the understanding of economic analysis is the relationship between time and money. An immediately available sum is more valuable than the identical sum in the future. Money decreases in value with time.

The term "discounted cash flow" describes the time value of money. The discount rate establishes the relationship between the value of money in one period and another, such that,

$$A = \frac{B}{(1+i)^t}$$

where

- A = value in the reference period
- B = value in another period
- i = discount rate expressed as a fraction per period
- t = number of periods between A and B. (t is positive when B is in the future and negative when B is in the past.)

Usually t is in years and i is the interest rate per year.

Present worth refers to the value in the current year of a cash flow stream. In the preceding equation, A is the present worth when the reference period is the current year. Sometimes present worth is used more loosely and refers to the first year of the project life. At other times present worth may be used to refer to the first year of plant operation when revenues are first generated. The present worth factor is  $[1/(1+i)]^t$  for year t.

Future value refers to the value in a future period of a single payment today or of a stream of payments over a period of years. The future worth factor is the reciprocal of the present worth factor,  $(1+i)^t$ .

#### NOMINAL VERSUS REAL RATES

Discount rates, interest rates, and escalation rates are specified as either nominal or real rates. Nominal rates are generally quoted and are used most often. Real rates are merely nominal rates that have been adjusted for inflation.

To convert a nominal rate into a real rate, the nominal rate is discounted by the inflation rate. That is,

$$\frac{(1+i)}{(1+p)} = (1+r)$$

where

- i = nominal rate (discount rate, interest rate, or escalation rate)
- p = inflation rate
- r = real rate.

Investment analysis can be performed using either nominal or real rates. However, two important rules to remember are as follows:

1. If real rates are chosen, all interest rates used throughout the analysis must be specified in real terms. If nominal rates are chosen, all interest rates throughout the analysis must be specified in nominal terms.
2. If real rates are used, all other monetary inputs (expenses, revenues, escalation rates, etc.) must be adjusted for inflation. The procedure for converting other monetary inputs into inflation-adjusted units is discussed in the next section.

#### CURRENT AND CONSTANT DOLLARS

Current and constant dollars are analogous to nominal and real interest or escalation rates; constant dollars are current dollars that have been adjusted for inflation. Current-dollar values are the actual amounts of money that will be spent or received in a given year. The conversion from current to constant dollars is achieved by dividing the current-dollar amount (1 + the inflation rate), or

$$\text{Constant Dollars} = \frac{\text{Current Dollars}}{(1+p)^t}$$

where

p = inflation rate per period  
t = number of periods.

Either constant or current dollars can be used when evaluating alternative investments. Again, the rule to remember is that constant dollars are used with real interest rates and that current dollars are used with nominal interest rates.

COGENERATION SYSTEM COST ESTIMATES

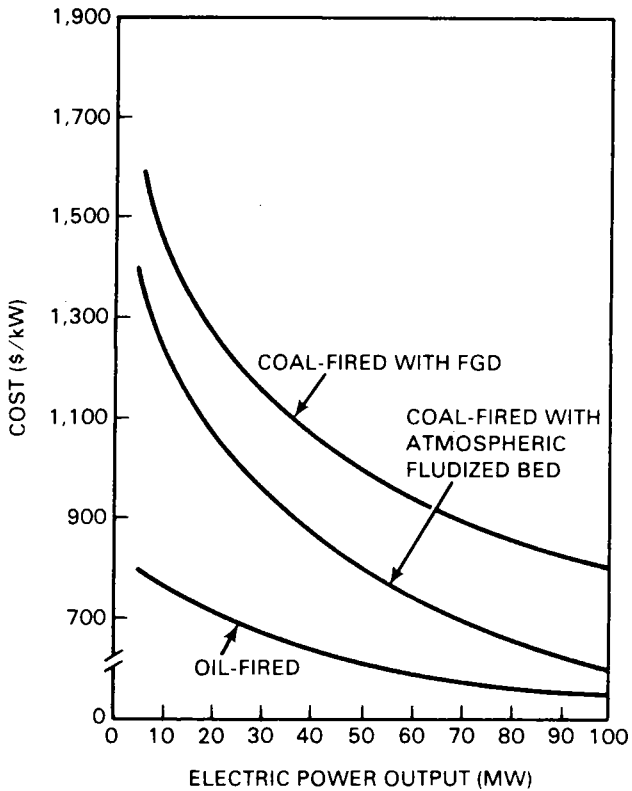

FIGURE F.1. Estimated Steam Turbine Cogeneration System Installed Costs With Different Heat Sources  
 Source: Office of Technology Assessment, February 1983. Industrial and Commercial Cogeneration. Congress of the United States. Washington, D.C.

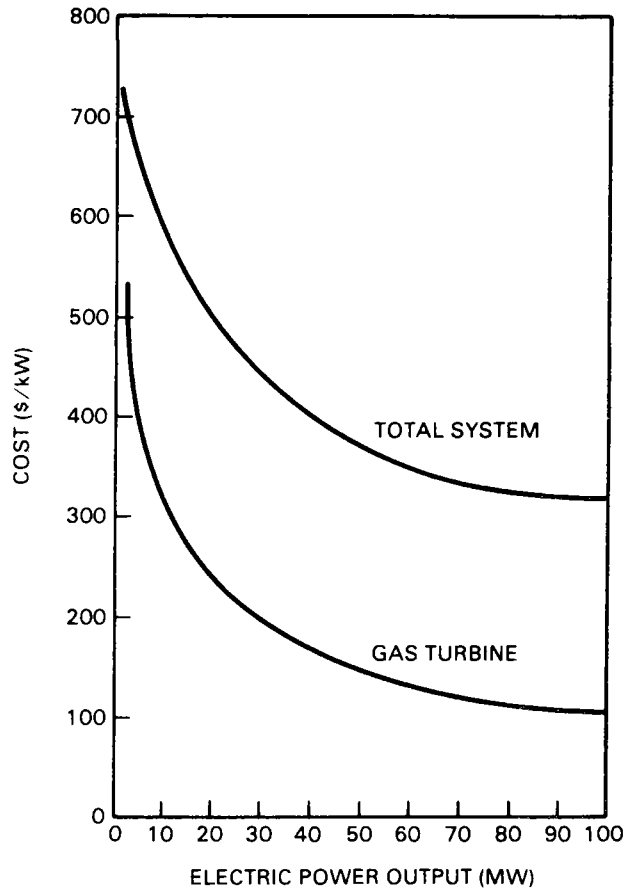

FIGURE F.2. Combustion Turbine Cogenerator Cost Estimates for the Prime Mover and Total Installed System  
 Source: Office of Technology Assessment, February 1983. Industrial and Commercial Cogeneration. Congress of the United States. Washington, D.C.

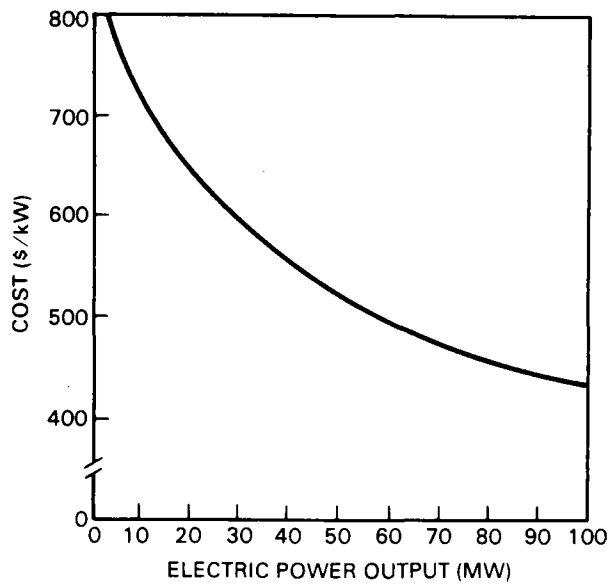

FIGURE F.3. Total Installed Costs for Combined-Cycle Cogenerator Systems

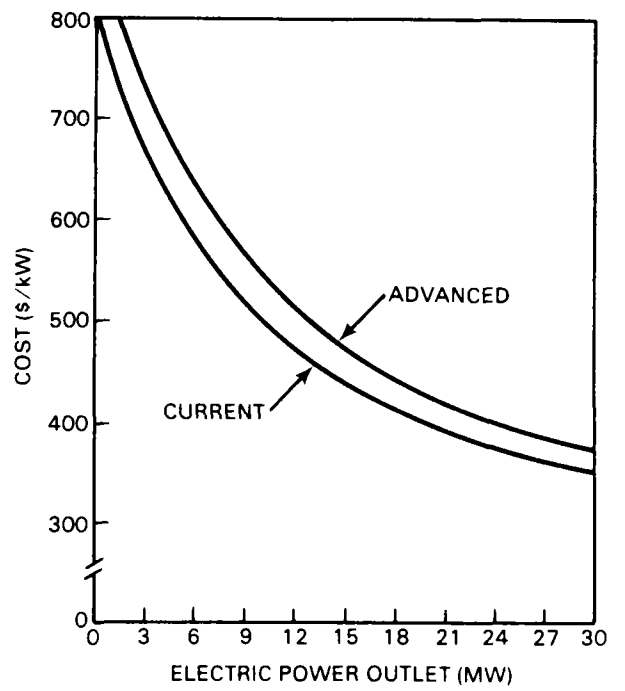

FIGURE F.4. Diesel Cogenerator Total Installed Costs for Current and Advanced Prime Movers

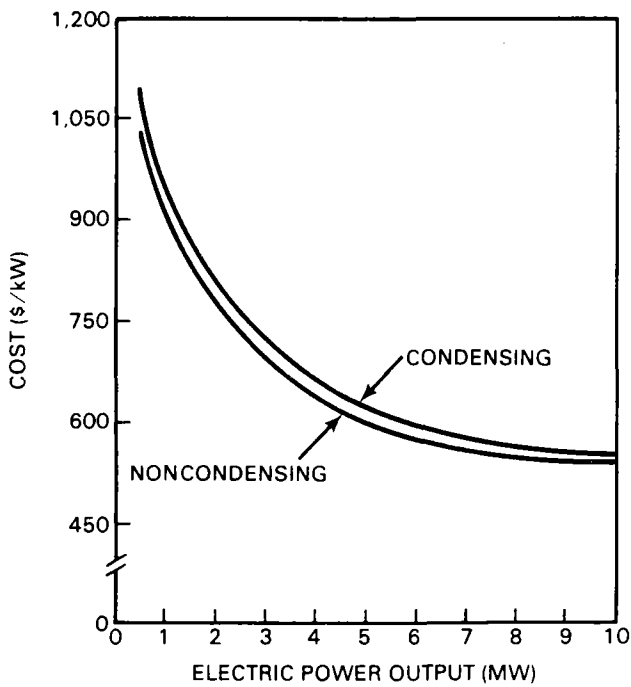

FIGURE F.5. Estimated Installed Costs for Condensing and Noncondensing Steam Rankine Bottoming Systems

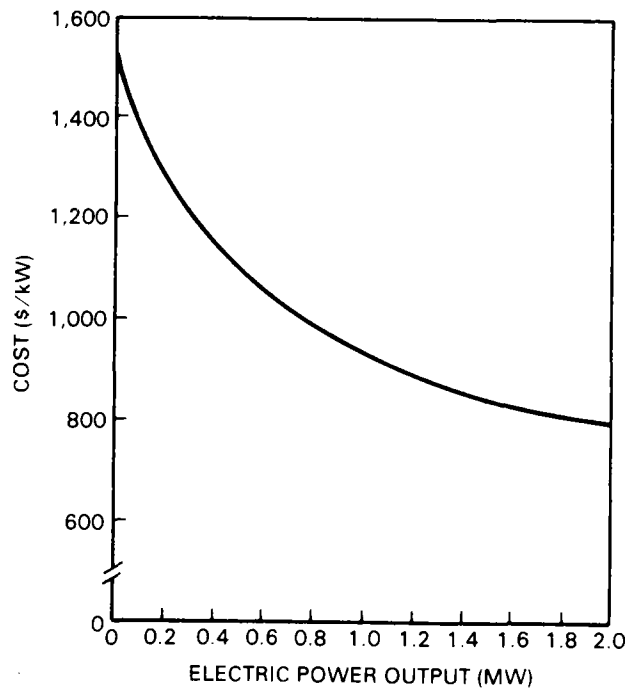

FIGURE F.6. Estimated Installed Costs for Organic Rankine Bottoming System



APPENDIX G

COGENERATION SYSTEM O&M COST ESTIMATES

APPENDIX G

COGENERATION SYSTEM O&M COST ESTIMATES  
(1980 Dollars)

	<u>Annual Fixed Costs (\$/kW Installed)</u>	<u>Annual Variable Costs (Mills/kWh)</u>
STEAM TURBINES	1.6 - 11.5	3.0 - 8.8
● Residual Oil-Fired		4.0
● Coal-Fired:		
-With Flue Gas Desulfurization		6.0
-Without Flue Gas Desulfurization		4.2
-With Atmospheric Fluidized Bed		5.2
-With Pressurized Fluidized Bed		8.8
OPEN-CYCLE COMBUSTION TURBINE		
● Simple	0.29	2.5
● Regenerative	0.34	
CLOSED-CYCLE COMBUSTION TURBINE	(5% of Installed Cost)	
COMBINED CYCLES <sup>(a)</sup>	5.0 - 5.5	3.0 - 5.1
DIESELS	6.0 - 8.0	5.0 - 10.1
● Large, Low-Speed		1.5
● Small, High-Speed		16.0

---

(a) Lowest O&M Costs are associated with natural gas, and highest with fuel oil

Source: Office of Technology Assessment. February 1983. Industrial and Commercial Cogeneration. Congress of the United States. Washington, D.C.

APPENDIX H

U.S. ENVIRONMENTAL PROTECTION AGENCY REGIONAL OFFICES

APPENDIX H

U.S. ENVIRONMENTAL PROTECTION AGENCY REGIONAL OFFICES

EPA Regional Office, Air Programs Branch	States Included in Region
1. John F. Kennedy Federal Building Room 2303 Boston, MA 02203 (617) 223-6883	Connecticut, Maine, Massachusetts, New Hampshire, Rhode Island, Vermont
2. Federal Office Building 26 Federal Plaza New York, NY 10007 (212) 264-2517	New Jersey, New York, Puerto Rico, Virgin Islands
3. Curtis Building Sixth and Walnut Streets Philadelphia, PA 19106 (215) 597-8175	Delaware, District of Columbia, Maryland, Pennsylvania, Virginia, West Virginia
4. 345 Courtland, NE, Atlanta, GA 30308 (404) 881-3043	Alabama, Florida, Georgia, Mississippi, Kentucky, North Carolina, South Carolina, Tennessee
5. 230 South Dearborn Chicago, IL 60604 (312) 353-2205	Illinois, Minnesota, Michigan, Ohio, Indiana, Wisconsin
6. First International Building 1201 Elm Street Dallas, TX 75270 (214) 767-2745	Arkansas, Louisiana, New Mexico, Oklahoma, Texas
7. 324 E. Eleventh Street Kansas City, MO 64106 (816) 374-5971	Iowa, Kansas, Missouri, Nebraska
8. 1860 Lincoln Street Denver, CO 80295 (303) 837-3471	Colorado, Montana, North Dakota, South Dakota, Utah, Wyoming
9. 215 Fremont Street San Francisco, CA 94105 (415) 556-4708	Arizona, California, Hawaii, Nevada, Guam, American Samoa
10. 1200 Sixth Avenue Seattle, WA 98101 (206) 442-1230	Washington, Oregon, Idaho, Alaska

Source: TRW, 1981.

APPENDIX I

STATES' COGENERATION RATE-SETTING UNDER PURPA

## APPENDIX I

## STATES' COGENERATION RATE-SETTING UNDER PURPA

STATE	STATUS	RATES	CONTACT
ALABAMA Public Service Commission	Rates adopted for facilities producing 100 kW or less. Larger facilities negotiate with utilities.	ALABAMA POWER CO.: For producers of 100 kW or less: Standard rate is 2.46 cents/kWh through October, and 2.42 cents/kWh November through May. Time-of-day rate is 2.96 cents/kWh peak and 2.46 cents/kWh off-peak June through October, and 2.68 cents/kWh peak and 2.42 cents/kWh off-peak November through May.	Wallace Tidmore, PSC, (205) 832-3421.
ALASKA Public Utilities Commission	Final rules issued. Utilities have begun filing proposed rates. Some rates have been approved; remainder should be approved this summer.	(for non-firm producers of less than 100 kW) ARCTIC UTILITIES (approved): 11.40 cents/kWh. KODIAK ELECTRIC ASSOCIATION (approved): 7.591 cents/kWh. CHUGACH ELECTRIC ASSOCIATION INC. (proposed): 0.685 cents/kWh	Judy White, PUC, (907) 276-6222.
ARIZONA Corporation Commission	Final rules issued. Rates in effect but subject to ACC investigation.	ARIZONA PUBLIC SERVICE CO.: Summer: 4.255 cents/kWh peak, 1.986 cents/kWh off-peak. Winter: 3.414 cents/kWh peak, 2.028 cents/kWh off-peak. Firm power suppliers receive an additional 10 percent.	Jim Apperson, ACC, (602) 255-4251
ARKANSAS Public Service Commission	Final rules issued. Arkansas Power & Light asked PSC to seek waiver of FERC rules requiring full avoided-cost payments, and has interim rates in effect not based on avoided costs.	ARKANSAS POWER & LIGHT CO.: Summer: 3.531 cents/kWh peak, 3.080 cents/kWh off-peak. Winter: 3.127 cents/kWh peak, 2.953 cents/kWh off-peak.	Dana Nixon, PSC, (501) 371-1792.
BONNEVILLE POWER ADMINISTRATION (serves several states)	EPA issued draft policy statement on "billing credits". Policy expected to encourage co-generators to sell to local utilities. Utilities would then receive billing credits from BPA. Revised draft may be issued for comment.	See listings for individual states and utilities.	BPA, (206) 442-1518.
CALIFORNIA Public Utilities Commission	Final rules issued. Workshops to consider standard long-term contract offers are expected to be held in July. Rates reviewed quarterly.	Rates are reviewed quarterly. Capacity credits listed are for 20-year contracts. PACIFIC GAS & ELECTRIC: 4.40 cents/kWh, capacity \$110/kW/year. SOUTHERN CALIFORNIA EDISON: 4.02 cents/kWh, capacity \$114/kW/year. SAN DIEGO GAS & ELECTRIC: 6.45 cents/kWh, capacity \$93/kW/year.	John Quinley, PUC, (415) 557-1159.
COLORADO Public Utilities Commission	Final rules issued. Utilities have filed proposed rates; PUC has begun proceeding to determine whether rates comply with rules.	PUBLIC SERVICE CO. OF COLORADO (proposed): 1.77 cents/kWh. Capacity, \$15.33/kW/month.	Michael Homyak, PUC, (303) 866-4300.
CONNECTICUT Department of Public Utility Commission	Final rules issued.	CONNECTICUT LIGHT & POWER CO.: Formula applies multipliers to utility's monthly average fossil fuel costs. Payments currently about 5 cents/kWh. Firm power: 117 percent peak, 92 percent off-peak. Non-firm power: 114 percent peak, 89 percent off-peak.	DPUC Research Division, (203) 827-1553.

Source: Energy User News, May 21, 1983.

APPENDIX I (contd)

STATE	STATUS	RATES	CONTACT
DELAWARE Public Service Commission	Final rules issued.	DELMARVA POWER & LIGHT CO.: Summer 6.37 cents/kWh peak, 3.16 cents/kWh off-peak. Winter: 6.25 cents/kWh peak, 3.73 cents/kWh off-peak.	Leon Ryan, PSC, (302) 736-3233.
DISTRICT OF COLUMBIA Public Service Commission	Final rules issued. Rates proposed.	POTOMAC ELECTRIC POWER CO.: Utility price offers range from 2.39 to 5.59 cents/kWh.	PSC, (202) 727-3062.
FLORIDA Public Service Commission	Rules issued, but new rules expected to be adopted by August, after PSC considers capacity payments. Recent Florida court order overturning PSC rules has been appealed; rules remain in effect pending outcome of appeal.	For facilities producing over 100 kW: FLORIDA POWER CORP.: 6.296 cents/kWh peak, 4.665 cents/kWh off-peak. FLORIDA POWER & LIGHT CO.: 5.029 cents/kWh peak, 4.260 cents/kWh off-peak. GULF POWER CO.: 3.523 cents/kWh peak, 2.166 cents/kWh off-peak. TAMPA ELECTRIC CO.: 4.201 cents/kWh peak, 3.722 cents/kWh off-peak. In addition, capacity payments may be negotiated if facility has annual availability of 70 percent or more.	Bonnie Davis, PSC, (904) 487-2740.
GEORGIA Public Service Commission	Final rules issued.	SAVANNAH ELECTRIC POWER CO.: Summer: 4.082 cents/kWh peak, 2.969 cents/kWh off-peak. Winter: 2.683 cents/kWh, all periods.	Sam Weaver, PSC, (404) 656-4141.
HAWAII Public Service Commission	Final rules issued.	HAWAIIAN ELECTRIC CO.: 6 to 6.60 cents/kWh.	Leroy Yuen, PSC, (808) 548-3990.
IDAHO Public Utilities Commission	Final rules and rates adopted. Idaho Power has asked PUC to lower payments, and has filed lawsuit challenging PUC's authority to require and approve long-term contracts.	Power is sold under contract, with price updated annually to reflect coal prices. Capacity payments vary with length of contract; rates listed are for 20-year contracts. IDAHO POWER CO.: 1.639 cents/kWh; capacity, \$232/kW/year. WASHINGTON WATER POWER CO.: 1.600 cents/kWh; capacity, \$202/kW/year. UTAH POWER & LIGHT CO.: 1.200 cents/kWh; capacity, \$188/kW/year.	William Drummond, PUC, (208) 334-3456.
ILLINOIS Commerce Commission	Final rules issued. Rates expected to be revised by June 30.	COMMONWEALTH EDISON: Summer: 5.31 cents/kWh peak, 2.90 cents/kWh off-peak. Winter: 5.17 cents/kWh peak, 3.37 cents/kWh off-peak. IOWA-ILLINOIS GAS & ELECTRIC: Summer: 2.30 cents/kWh peak, 1.19 cents/kWh off-peak. Winter: 2.38 cents/kWh peak, 1.28 cents/kWh off-peak. SOUTH BELOIT WATER, GAS & ELECTRIC CO.: 2.65 cents/kWh peak, 1.93 cents/kWh off-peak.	Joseph Gillan, ICC, (217) 785-0326.
INDIANA Public Service Commission	Rules and rates approved, but may change after hearings in late May.	NORTHERN INDIANA PUBLIC SERVICE CO. (NIPSCO): Rates range from 2.46 cents/kWh winter off-peak to 3.33 cents/kWh summer peak. PUBLIC SERVICE CO. OF INDIANA: 1.330 cents/kWh.	William Boyd, PSC, (317) 232-2711.

APPENDIX I (contd)

STATE	STATUS	RATES	CONTACT
IOWA State Commerce Commission	Final rules issued; rates now being investigated.	IOWA PUBLIC SERVICE CO.: Option A: 1.82 cents/kWh. Option B: 2.03 cents/kWh peak, 1.64 cents/kWh off-peak. IOWA-ILLINOIS GAS & ELECTRIC: Option A: 1.88 cents/kWh summer, 1.63 cents/kWh winter. Option B: Rates range from 1.29 cents/kWh winter off-peak to 2.55 cents/kWh summer peak. Capacity payment determined by formula involving kWh delivered during peak, and utility's cost to borrow power from power pool.	Robert Latham, ISSC, (515) 281-5701.
KANSAS Corporation Commission	KCC issued final rules requiring utilities to file rates. Kansas City Power and Light Co. lawsuit challenging KCC's authority to require long-term contracts expected to be heard by State Supreme Court.	KANSAS GAS & ELECTRIC CO.: Rates equal to utility's total cost of fuel and purchased power as determined by monthly energy adjustment clause. Average rates currently 2 to 2.5 cents/kWh. Capacity payments determined by formula.	Eva Powers, KCC, (913) 296-5468.
KENTUCKY Utility Regulatory Commission	Final rules issued. Rates proposed.	KENTUCKY UTILITIES CO.: 1.5 cents/kWh. LOUISVILLE GAS & ELECTRIC: 1.7 cents/kWh.	Richard Heman, KURC, (502) 564-3940.
LOUISIANA Public Service Commission	Final rules issued. Utilities must file standard tariff rates and avoided costs by late May.	Not available.	Arnold Chauviere, PSC, (504) 342-1403.
MAINE Public Utilities Commission	Final rules issued.	Revised periodically in fuel adjustment proceedings. Rates listed are for June. CENTRAL MAINE POWER CO.: 4.6 cents/kWh peak, 3.7 cents/kWh off-peak. BANGOR HYDROELECTRIC CO. (for producers of 1,000 kW or less): 4.0 cents/kWh peak, 3.3 cents/kWh off-peak.	PUC, (207) 289-3831.
MARYLAND Public Service Commission	Final rules issued. Filings approved for most utilities; further hearings to be held to consider capacity payments.	POTOMAC ELECTRIC POWER CO. (PEPCO): Rates range from 2.641 cents/kWh for winter off-peak to 5.276 cents/kWh for summer peak. POTOMAC EDISON CO.: 1.57 cents/kWh. DELMARVA POWER & LIGHT CO.: Rates range from 2.52 cents/kWh winter off-peak to 4.22 cents/kWh summer peak. BALTIMORE GAS & ELECTRIC CO.: Rates range from 1.98 cents/kWh winter off-peak to 5.97 cents/kWh summer peak.	Paul Daniel, PSC, (301) 659-6021.
MASSACHUSETTS Department of Public Utilities	Final rules issued. Rates proposed.	WESTERN MASSACHUSETTS ELECTRIC: 5.06 cents/kWh peak Fuel Charge Division, and 4.36 cents/kWh off-peak, or a flat 4.70 cents/kWh.DPU, (617) 727-9748. MASSACHUSETTS ELECTRIC: 4.92 cents/kWh peak and 3.32 cents/kWh off-peak, or a flat 4.07 cents/kWh. BOSTON EDISON CO.: 5.22 cents/kWh peak and 3.79 cents/kWh off-peak, or a flat 4.45 cents/kWh.	
MICHIGAN Public Service Commission	Final rules issued.	For non-firm power: 3.0 cents/kWh. For firm power: 5 to 6 cents/kWh (including capacity payment).	Donald Johns, PSC, (517) 373-8171.



APPENDIX I (contd)

STATE	STATUS	RATES	CONTACT
MINNESOTA Public Service Commission	Final rules issued. Utilities have until June 24 to file rates.	NORTHERN STATES POWER (100 kW or less): Option A: 2.67 cents/kWh peak, 1.66 cents/kWh off-peak. Under Option B, rates depend on length of contract signed, and are adjusted each year. Option B rates for 1982 range from 2.28 cents/kWh for a 5-year contract to 3.40 cents/kWh for a 25-year contract.	Stuart Mitchell, PSC, (612) 296-8662.
MISSISSIPPI Public Service Commission	No rules issued or rates approved.	Not available.	Keith Howle, PSC, (601) 354-7265.
MISSOURI Public Service Commission	Final rules issued. Utilities filed rates ranging from 1.5 to 5.0 cents/kWh, which have been suspended pending an investigation. Only Kansas City Power & Light Co.'s rates have been approved to date.	KANSAS CITY POWER & LIGHT CO. (for non-firm producers of under 100 kW): 1.63 cents/kWh.	PSC, (314) 751-3234.
MONTANA Public Service Commission	PSC issued final rules, but will review rules and rate methodology in hearings beginning June 21. Montana Power Co. filed motion to dismiss new proceeding, saying PSC lacks authority.	(Long-term rate requires 4-year contract). MONTANA POWER CO.: 2.34 cents/kWh short-term power, 4.09 cents/kWh long-term power, 6.74 cents/kWh peak. PACIFIC POWER & LIGHT CO.: 7.76 cents/kWh short-term peak, 1.84 cents/kWh short term off-peak, 6.05 cents/kWh long-term peak, 4.03 cents/kWh long-term off-peak. MONTANA-DAKOTA UTILITIES CO.: 2.16 cents/kWh short-term, 5.58 cents/kWh long term, 5.53 cents/kWh peak.	Ted Otis, PSC, (406) 449-2649
NEBRASKA	Nebraska has 166 municipal and 4 cooperative utilities, which are not regulated by any state body and set their own cogeneration rates and rules.	OMAHA PUBLIC DISTRICT (for producers of 100 kW or less): Summer: 1.60 cents/kWh peak and 1.00 cents/kWh off-peak, or flat 1.10 cents/kWh. Winter: 1.20 cents/kWh peak and 1.00 cent/kWh off-peak, or flat 1.10 cents/kWh.	Individual Nebraska Utilities
NEVADA Public Service Commission	Rules issued.	NEVADA POWER CO.: Summer: 3.81 cents/kWh peak, 2.33 cents/kWh off-peak. Winter: 2.99 cents/kWh peak, 2.27 cents/kWh off-peak. Capacity payments available to reliable facilities that meet certain conditions. Capacity payment \$7.65 per kW peak, 24 cents/kW off-peak.	PSC, (702) 885-3409.
NEW HAMPSHIRE Public Utility Commission	Rules and rates issued, but rate revision hearings to be held this summer.	7.7 cents/kWh. 8.2 cents/kWh for reliable facilities.	Sarah Voll, PUC, (603) 271-2437.
NEW JERSEY Board of Public Utilities	Final rules issued. Further hearings may be held.	Energy payments equal 110 percent of rate utilities pay for power from Pennsylvania-New Jersey-Maryland (PJM) power pool. Capacity payments also tied to power pool rates. PUBLIC SERVICE ELECTRIC & GAS CO. Rates range from 3.697 cents/kWh winter off-peak to 8.14 cents/kWh summer peak. Capacity, \$30.66/kW/yr. ATLANTIC CITY ELECTRIC CO.: 5.36 cents/kWh guaranteed minimum. Capacity, \$30.66/kW/year.	Steve Gable, BPU, (201) 648-3448.

## APPENDIX I (contd)

STATE	STATUS	RATES	CONTACT
NEW MEXICO Public Service Commission	Rules issued.	(for producers of 100 kW or less) PUBLIC SERVICE CO OF NEW MEXICO: Primary voltage (power bought at 12.6 kv): Summer: 4.89 cents/kWh peak and 2.99 cents/kWh off-peak, or flat 3.47 cents/kWh. Winter: 4.95 cents/kWh peak and 4.05 cents/kWh off-peak or flat 3.83 cents/kWh. Secondary voltage (power bought at less than 12.6 kv): Summer: 5.23 cents/kWh peak and 3.23 cents/kWh off-peak, or flat 3.66 cents/kWh. Winter: 5.24 cents/kWh peak and 4.33 cents/kWh off-peak, or flat 4.01 cents/kWh.	Tom Halpin, PSC, (505) 827-3361.
NEW YORK Public Service Commission	PSC issued final order in case of Consolidated Edison Co. of New York Inc. (Con Ed) and approved Con Ed's rates. Other utilities filed rates based on this order; other utilities' rates expected to be approved by end of summer. Con Ed is challenging PSC rules in state court.	State law sets minimum average of 6 cents/kWh. Rates listed are proposed, except for Con Ed's, which are approved. CONSOLIDATED EDISON (over 900 kW, low-tension service): Summer: 12.37 cents/kWh peak, 4.77 cents/kWh off-peak. Winter: 6.57 cents/kWh peak, 4.37 cents/kWh off-peak. NIAGARA MOHAWK POWER: 5.46 cents/kWh peak (includes capacity payment), 4.00 cents/kWh off-peak. ORANGE & ROCKLAND UTILITIES: Summer: 6.733 cents/kWh peak (includes capacity payment), 4.179 cents/kWh off-peak. Winter: 5.408 cents/kWh peak, 4.836 cents/kWh off-peak. CENTRAL HUDSON GAS & ELECTRIC (rates include capacity payments): secondary voltage: 9.98 cents/kWh summer peak, 7.57 cents/kWh winter peak, 5.84 cents/kWh spring/fall peak, 4.29 cents/kWh off-peak. Primary voltage: 10.64 cents/kWh summer peak, 8.10 cents/kWh winter peak, 6.27 cents/kWh spring/fall peak, 4.58 cents/kWh off-peak. Transmission voltage: 10.12 cents/kWh summer peak, 7.68 cents/kWh winter peak, 5.92 cents/kWh spring/fall peak, 4.45 cents/kWh off-peak.	Craig Indyke, PSC, (518) 474-6515.
NORTH CAROLINA Utilities Commission	Final rules issued. Proposed new rates now being reviewed; approval expected in June.	{proposed) CAROLINA POWER & LIGHT CO.: 4.25 cents/kWh peak, 2.73 cents/kWh off-peak, 5-year contract; 4.93 cents/kWh peak, 3.08 cents/kWh off-peak. 10-year contract: 5.98 cents/kWh peak, 3.62 cents/kWh off-peak. 15-year contract: 7.68 cents/kWh peak, 4.49 cents/kWh off-peak. Capacity payments based on kWh supplied during peak hours. Capacity: 5-year or 10-year contract: 2.15 cents/kWh summer peak, 1.86 cents/kWh non-summer peak. 15-year contract: 3.63 cents/kWh summer peak, 3.14 cents/kWh non-summer peak. DUKE POWER CO.: 3.03 cents/kWh peak, 2.13 cents/kWh off-peak. 5-year contract: 3.27 cents/kWh peak, 2.25 cents/kWh off-peak. 10-year contract: 4.08 cents/kWh peak, 2.63 cents/kWh off-peak. 15-year contract: 4.79 cents/kWh peak, 3.27 cents/kWh off-peak. Capacity payment: 1.27	Tim Carrere, UC, (919) 733-2267.

APPENDIX I (contd)

STATE	STATUS	RATES	CONTACT
NORTH CAROLINA (Continued)		cents/kWh summer peak, 0.77 cents/kWh non-summer peak. 5-year or 10-year contract: 1.39 cents/kWh summer peak, 0.84 cents/kWh non-summer peak. Contracts for 11 years or longer: 1.83 cents/kWh summer peak, 1.10 cents/kWh non-summer peak.	
NORTH DAKOTA Public Service Commission	Final rules issued.	For cogenerators producing over 500 kW: 1.6 to 3.0 cents/kWh.	Steven Kahl, PSC, (701) 224-4078.
OHIO Public Utilities Commission	Interim rules issued. Utilities have proposed rates, which will be investigated by PUC.	OHIO POWER CO.: 1.70 to 2.00 cents/kWh.	Alan Pound, PUC, (614) 466-7750.
OKLAHOMA Corporation Commission	Final rules issued. Interim rates approved for facilities producing under 100 kW; proceedings initiated to determine appropriate avoided-cost methodology; hearings expected.	(interim rates for 100 percent reliable facilities) PUBLIC SERVICE CO. OF OKLAHOMA: 4.054 cents/kWh peak, 2.744 cents/kWh off-peak. OKLAHOMA GAS & ELECTRIC: 3.308 cents/kWh.	Jim Winters, OCC, (405) 521-2335.
OREGON Public Utility Commission	Final rules issued. Utilities filed rates, but are required by July 1 to file rates based on avoided costs.	3.8 to 4.5 cents/kWh.	Leon Hagen, PUC, (503) 378-7998.
PENNSYLVANIA Public Utility Commission	Final rules issued. Utilities have proposed rates. Four utilities have challenged PUC rules in state court.	PENNSYLVANIA POWER & LIGHT CO.: 6 cents/kWh to cogenerators who use only renewable resources.	Tom Clift, PUC, (717) 783-1373.

## APPENDIX I (contd)

STATE	STATUS	RATES	CONTACT
RHODE ISLAND Public Utility Commission	Final order issued.	NARRAGANSETT ELECTRIC CO.: 5.384 cents/kWh peak and 4.038 cents/kWh off-peak, or flat 4.736 cents/kWh. BLACKSTONE VALLEY ELECTRIC CO.: Primary voltage: 5.643 cents/kWh peak and 4.293 cents/kWh off-peak, or flat 4.871 cents/kWh. Secondary voltage: 5.920 cents/kWh peak and 4.420 cents/kWh off-peak, or flat 5.058 cents/kWh. NEWPORT ELECTRIC CO.: 4.54 cents/kWh peak and 4.14 cents/kWh off-peak, or flat 4.38 cents/kWh. PASCOAG FIRE DISTRICT: 3.085 cents/kWh peak, 2.902 cents/kWh off-peak. BLOCK ISLAND POWER CO.: 14.465 cents/kWh.	Doug Hartley, PUC, (401) 277-3500.
SOUTH CAROLINA Public Service Commission	Final rules issued. Rates approved.	SOUTH CAROLINA ELECTRIC & GAS CO.: 3.26 cents/kWh peak, 2.275 cents/kWh off-peak. Capacity, \$2.75/kW/month. CAROLINA POWER & LIGHT CO.: 2.80 cents/kWh peak, 2.07 cents/kWh off-peak. Capacity, \$3.89/kW/month July through October, \$3.35/kW/month November through June. DUKE POWER CO.: 1.9 cents/kWh peak, 1.49 cents/kWh off-peak. Capacity, \$5.00/kW/month.	Randy Watts, PSC, (803) 758-5362.
SOUTH DAKOTA Public Utilities Commission	Final rules issued. Rates approved for facilities producing 100 kW or less.	BLACK HILLS POWER & LIGHT CO.: 1.30 to 3.50 cents/kWh.	Walter Washington, PUC, (605) 773-3201.
TENNESSEE Public Service Commission (regulates one electric utility serving non-TVA customers)	Hearing held to consider rates filed by utility. Final order not expected soon.	(proposed) KINGSPOUR POWER CO.: 1.36 cents/kWh peak and 0.81 cents/kWh off-peak, or flat 0.81 cents/kWh. Capacity, \$3.00/kW/month if on time-of-day metering, otherwise \$1.50/kW/month.	PSC, (615) 741-2125.
TENNESSEE VALLEY AUTHORITY (serves several states) TVA Board of Directors	Experimental rates and interim rules extended to October. New rules issued for purchase of power from cogeneration outside TVA area.	(interim) 4.64 cents/kWh peak and 2.92 cents/kWh off-peak, or flat 3.44 cents/kWh.	Harold Usher. TVA, (615) 751-0011.
TEXAS Public Utility Commission	Final rules issued. Utilities have filed rates. Houston Lighting & Power Co. has asked for decrease in rates.	HOUSTON LIGHTING & POWER CO.: Option A: Multipliers applied to utility's average fuel cost, currently about 3.0 cents/kWh. For non-PURPA-qualifying facilities, multipliers are 1.31 summer peak, 1.01 summer off-peak, 1.13 winter. For qualifying facilities, multipliers are 1.64 summer peak, 1.27 summer off-peak, 1.42 winter. Option B (available to qualifying facilities over 5000 kW): hourly payment based on avoided cost formula.	Mike Williams, PUC, (512) 458-0202.

APPENDIX I (contd)

STATE	STATUS	RATES	CONTACT
UTAH Public Service Commission	Final rules issued. Hearing to review policy and revise rates scheduled for July 18.	UTAH POWER & LIGHT CO. (for producers of 1,000 kW or less): 2.2 cents/kWh non-firm, 2.6 cents/kWh firm.	Douglas Kirk, PSC, (801) 533-3247.
VERMONT Public Service Commission	Final rules issued. Hearings on revised rate expected to be held in July.	9 cents/kWh peak and 6.6 cents/kWh off-peak, or 7.8 cents/kWh.	Peter Zamore, PSB, (802) 828-2880.
VIRGINIA State Corporation Commission	Final rules issued. Rates approved.	VIRGINIA ELECTRIC & POWER CO. (Vepco): 5.203 cents/kWh peak, 3.132 cents/kWh off-peak. Capacity: 0.803 cents/kWh for facilities operating less than five years. APPALACHIAN POWER CO.: Rates range from 1.36 cents/kWh winter off-peak to 1.7 cents/kWh summer peak. Capacity: \$3.00/kW/month seasonal peak, \$1.50/kW/month off-peak.	Bill Stephens, SCC, (804) 786-4932.
WASHINGTON Utilities and Transportation Commission	Final rules issued. Rates approved.	PUGET SOUND POWER & LIGHT CO.: 2.07 cents/kWh. Pacific Power & Light: 2.795 cents/kWh.	Dick Bostwick, UTC, (206) 753-1096.
WEST VIRGINIA Public Service Commission	Rules proposed. Issuance of final rules had been awaiting outcome of American Electric Power lawsuit.	(proposed) MONONGAHELA POWER CO.: 1.00 to 2.00 cents/kWh.	Rich Hitt, PSC, (304) 348-2174.
WISCONSIN Public Service Commission	Rates in effect. Hearings continuing. Final rules expected in June.	WISCONSIN POWER & LIGHT CO.: 4.8 cents/kWh peak, 1.75 cents/kWh off-peak. MADISON GAS & ELECTRIC CO.: 2.75 cents/kWh summer peak, 2.22 cents/kWh winter peak, 1.50 cents/kWh off-peak. WISCONSIN ELECTRIC POWER: 3.65 cents/kWh summer peak, 3.45 cents/kWh winter peak, 1.45 cents/kWh off-peak. NORTHERN STATES POWER CO.: 1.60 cents/kWh peak, 1.14 cents/kWh off-peak. Capacity: \$4.00/kW/month. LAKE SUPERIOR DISTRICT POWER CO.: 1.90 cents/kWh. Capacity: \$6.02/kW/month. WISCONSIN PUBLIC SERVICE CORP.: 1.85 cents/kWh peak, 1.32 cents/kWh off-peak. Capacity payments determined by each facility's degree of firmness.	Jennifer Fagen, PSC, (608) 266-5620.
WYOMING Public Service Commission	Final rules issued.	CHEYENNE LIGHT, FUEL & POWER CO. (for non-firm producers of 100 kW or less): 4.05 cents/kWh.	Dave Walker, PSC, (307) 777-7427.

APPENDIX J

OPERATING AND EFFICIENCY STANDARDS FOR QUALIFYING FACILITIES

APPENDIX J

OPERATING AND EFFICIENCY STANDARDS FOR QUALIFYING FACILITIES

To be a qualifying facility, all topping-cycle cogenerators must meet FERC's operating standard. If oil or natural gas is used by new topping-cycle cogenerators, an efficiency standard must be met as well. No operating standards must be met by bottoming-cycle cogenerators; however, if oil or natural gas is used for supplementary firing, an efficiency standard must be met in order to be a qualifying facility. The operating and efficiency standards applicable to topping and bottoming cycles are listed in Table J.1. Information calculated in Table 3.1 can be used to determine whether the topping cycle standards have been met.

TABLE J.1. Operating and Efficiency Standards for Qualifying Facilities

Topping-Cycle Cogenerators:

- Operating Standard. The useful thermal output of the facility must, during any calendar year, be no less than 5 percent of the total energy output, regardless of the fuel used or the date of installation.
- Efficiency Standard. If any of the energy input is natural gas or oil and installation of the cogeneration facility began on or after March 13, 1980, the useful power output of the facility plus one-half the useful thermal output during any calendar year must:
  - be no less than 42.5 percent of the total energy input of natural gas or oil, or
  - be no less than 45 percent of the total energy input of natural gas and oil if the useful thermal energy output is less than 15 percent of the total energy output of the facility.

Bottoming-Cycle Cogenerators:

- Operating Standard. None.
- Efficiency Standard. If any of the energy input as supplementary firing is natural gas or oil, and the installation of the facility began or after March 13, 1980, the useful power output must, during any calendar year, be no less than 45 percent of the energy input of the natural gas and oil use for supplementary firing.

SOURCE: TRW Energy Engineering Division. October 1981. Handbook of Industrial Cogeneration. DOE/TIC-11605. McLean, Virginia.

APPENDIX K

PRECONCEPTUAL-DESIGN PHASE DESCRIPTION OF EVENTS



APPENDIX K

PRECONCEPTUAL-DESIGN PHASE DESCRIPTION OF EVENTS

0.0 Start Preconceptual-Design Phase

1.0 to 1.1 Development of Data-Collection-and-Analysis Plan

- Develop scope of work
  - identify data elements required
  - identify sources of data
  - identify types of analyses to be performed (and methodology)
  - develop logical subtasks and sequences
- Develop task/subtask schedules
- Assign responsibilities and identify available resources
- Identify outside resources (if required)
- Coordinate plan with management as required.

2.0 to 2.8 Load-Analysis Phase

2.1 to 2.2 Determination of Existing Thermal and Electrical Loads

- Determine/analyze existing thermal loads
  - identify process/non-process loads
  - develop annual profiles of steam and chilled water (if applicable) use
  - develop 24-hour profiles of steam and chilled water use
    - \* summer max. - weekday, weekend
    - \* winter max. - weekday, weekend
    - \* spring and fall - typical weekday, weekend
  - develop 24-hour profiles of process and non-process hot water requirements
- Determine/analyze existing electrical loads
  - annual profile by month
  - daily 24-hour profiles
    - \* winter max. - weekday, weekend
    - \* summer max. - weekday, weekend
    - \* spring/fall - typical weekday, weekend

2.3 - 2.4 Determine Effects of Other Plans:

- Determine effects of any on-going or future energy conservation measures on existing historical data
- Determine potential effects of any planned future expansion plans on future electrical/thermal loads

2.5 Develop Net Future Electrical/Thermal Load Requirements

- Integrate existing historical data with projected changes to develop projected load requirements

2.6 - 2.7 Determine Condition of Existing Thermal/Electrical Equipment and Associated Distribution Systems

● Thermal:

- steam plant:

- \* energy consumption vs. steam output
- \* type of fuels used
- \* auxiliary loads
- \* steam production capacity (hourly)
- \* make-up water requirements
- \* stack temperatures
- \* excess air quantities
- \* maintenance schedules

- thermal distribution system:

- \* routing of lines
- \* piping sizes, operating temperatures/pressures
- \* condition of lines, valves, steam traps, cooling towers, etc.
- \* ability to handle potential cogeneration temperatures/pressures

- plant ability to handle additional equipment
- water chiller plant (if applicable)

- \* capacity/loads
- \* condition

2.8 Complete Load-Analysis Phase

3.0 - 3.5 Perform Constraint Analysis

3.1 - 3.2 Preliminary Institutional Constraint Analysis

Examine potential constraints to cogeneration with respect to:

- Regional master planning and zoning
- Citizens' groups (if applicable)
- Building codes
- Legislative restrictions
- Regulatory implications
- Electrical utility considerations

3.3 - 3.4 Preliminary Environmental Assessment

- Emissions
- Odor
- Groundwater
- Waste disposal
- Noise
- Additional transportation impact
- Fuels storage

4.0 - 4.7 Development of Cogeneration Configuration Options

4.1 - 4.2 Technology Assessment

- Determine existing technologies and possible mixes of equipment
  - boiler types
  - steam turbines
  - gas turbines
  - diesels
  - generators
  - utility interconnection techniques

- 4.3 - 4.4 Primary and Alternative Fuels Considerations:
  - Coal, solid waste, coal/oil mix, RDF/coal mix, gas, biomass
  - Fuel sources and impacts or any change from present fuel(s)
  - Storage and handling considerations
- 4.5 - 4.6 Preliminary Site Analysis
  - Capability of existing site to handle cogeneration facility
  - Possible alternative sites
  - New facilities requirements (?)
  - Potential impact on institutional factors (3.1)
- 4.7 Develop Tentative Cogeneration Configurations
- 4.8 Select and Size Major Components for Tentative Cogeneration Configurations
  - Integrate load-analysis data
  - Available technologies
  - Environmental requirements
- 4.9 Select Technically-Feasible Options of Cogeneration Configurations
  - Site capabilities
  - Minimal distribution system impact
- 5.0 - 5.7 Develop Cost and Financial Data
- 5.1 - 5.2 Develop Cost Estimates for Various Cogeneration Options
- 5.3 - 5.4 Develop Cost Estimates for Facility and Distribution Systems Upgrading as Required
- 5.5 - 5.6 Evaluate Various Ownership and Financing Techniques
  - Self-owned
    - self-operated
    - other-operated (utility or 3rd party)
  - Utility-owned
    - utility-operated
    - self-operated
  - 3rd-party-owned
    - 3rd-party-operated
    - self-operated
    - utility-operated
  - Financing techniques
    - leasing
    - self-financed
    - borrowed funds
    - other
- 6.0 - 6.2 Initiate Utility Discussions
  - Discuss technical options and potential impacts on inter-connection
  - Obtain utility comments/feedback as appropriate for incorporation into system decision process
  - Determine utility charges for standby capacity, energy buy-back, other costs (interconnection, design assistance, additional equipment, etc.)

7.0 Perform System Ranking and Trade-Off Analysis

- Optimize equipment efficiencies
- Optimize load requirements
- Rank options by cost and performance
- Examine pros and cons of each option
- Evaluate trade-offs
  - costs
  - regulatory/environmental
  - operational availability/reliability, etc.

8.0 Option Selection

- Determine go/no-go decision
- Select best all-around configuration for energy manager's requirements (if "go" decision)

9.0 Economic Analysis of Cogeneration Options

- Conduct thorough economic analysis of each technically-feasible option
  - investment costs
  - life-cycle costs
  - payback (ROI)
  - effects of fuel-cost escalation
  - effects of electrical-cost escalation

10.0 Complete Preconceptual-Design Phase

APPENDIX L

CONCEPTUAL-DESIGN PHASE DESCRIPTION OF EVENTS

CONCEPTUAL-DESIGN PHASE DESCRIPTION OF EVENTS0.0 Start Conceptual-Design Phase1.0 - 1.1 Subsystem Optimization

Optimize following subsystems for size, efficiency, cost, and reliability:

- Generator units
- Steam systems (main steam, turbine exhaust, process, and HVAC).
- Boiler-feedwater system
- Condensate and condensate-makeup systems
- Continuous blowdown and heat-recovery system
- Fuel-unloading-and-storage system
- Daily fuel-transfer-and-storage system
- Secondary fuel-handling-and-storage system
- Residue-handling system
- Boiler draft and flue-gas system
- Auxiliary-electric system
- Thermal-distribution system

2.0 - 2.1 Plant Site Analysis

- Optimize plant site layout (plant site, fuel storage, etc.)
- Layout thermal-distribution system
- Determine interconnection routing
- Determine main electrical distribution routing

3.0 - 3.1 Develop Plant Configuration

- Optimize layout of subsystems within plant

4.0 - 4.1 Develop Outline Specifications (a)

- Identify major system components
- Indicate:
  - performance characteristics
  - general features

5.0 - 5.1 Develop Construction Cost Estimate

- Develop cost estimate addressing:
  - engineering (final design)
  - construction supervision (A&E)
  - construction (cogeneration plant and associated facilities, revamp of other existing facilities/subsystems)
- Base costs on applicable equipment and labor escalation rates

---

(a) Refer to checklist (Appendix O) to select items for initial identification.

6.0 - 6.1 Develop Construction Schedule Estimate

- Estimate detailed-design period
- Identify long-lead-time (LLT) items and establish milestones for ordering and receipt of LLT items
- Establish milestones for:
  - bid-package availability
  - proposal receipt and review
  - construction contract negotiation and award
  - key construction phases
  - construction completion and inspection
  - system shakedown (initial operation)
  - system on-line operation

7.0 - 7.1 Final Life-Cycle-Cost Analysis

- Conduct life-cycle-cost analysis based on refined equipment and projected construction costs
- Include sensitivity analysis to determine effects of projected power, fuel, and labor costs

8.0 - 8.1 Develop Funding Schedule

Based on identification of long-lead-time items, proposed design and construction schedules, and construction cost estimates, determine time-phased requirements for funding and cash disbursements

9.0 - 9.1 Liaison and Regulatory Approval

This phase encompasses all required actors concerning required liaison and permit gathering, including:

- In-house management
- Federal, state, and local regulatory agencies
- Utilities
- Public interest groups (as appropriate)
- Equipment vendors
- Financial institutions
- Fuel suppliers
- Transportation agencies (fuel and waste disposal)

NOTE: Items 10.0 through 14.1 below lead to the development of an Environmental Impact Statement or Assessment, as may be required, depending upon complexity and size of the proposed cogeneration facility.

10.0 - 10.1 Land-Use Regulatory Analysis

Determine relationship of proposed project to local land-use plans (if appropriate)

- Land area required
- Changes in terrain

11.0 - 11.1 Community and Transportation Impact Analysis

- Community impacts:
  - height of facilities (stacks, etc.)
  - observable activities
  - noise and other aesthetic considerations
- Transportation impacts
  - access to facilities
  - increased traffic (fuel delivery, waste disposal, construction activities, etc.)

12.0 - 12.1 Plant Siting Impact Analysis

Effects on such items as:

- Geology
- Hydrology
- Economic and social factors
- Air quality
- Aquatic ecosystems (if appropriate)
- Terrestrial environment

13.0 - 13.1 Identification of Unavoidable Adverse Effects

- During plant construction
- During plant operation

14.0 - 14.1 Irreversible and Irretrievable Commitment of Resources

- Fuel and other energy
- Land
- Water
- Other

15.0 Complete Environmental Impact Statement (Assessment)

Integrate information from items 10.0 through 14.1. Structure in format per local environmental regulatory requirements.



APPENDIX M

DETAILED-DESIGN-AND-CONSTRUCTION PHASE DESCRIPTION OF EVENTS

## APPENDIX M

### DETAILED-DESIGN-AND-CONSTRUCTION PHASE DESCRIPTION OF EVENTS

#### 0.0 Start Detailed-Design-and-Construction Phase

##### 1.0 - 1.5 Detailed Design

Typical activities during this phase include:

- Award of the detailed-design engineering contract
- Finalization of all design calculations
- Identification of long-lead-time (LLT) items, development of detailed procurement specifications for these items, and placement of orders for these items. Typical items which may fall into this category include:
  - turbines
  - boilers
  - transformers
  - fuel and waste-handling equipment
  - air-quality-control equipment
- Development of detailed procurement and construction specifications for balance of plant (refer to Appendix 0 for selection of items to be addressed)
- Development of detailed design, construction, and installation drawings
- Development of system check-out procedures
- Preparation of bid packages for construction and installation proposals

##### 2.0 Issuance of Bid Packages and Evaluation of Proposals

- Bidding instructions
- Proposal submission date
- Detailed specifications
- Appropriate drawings
- Other instructions as appropriate
- Completion of detailed-design drawings (to include architectural drawings as appropriate)
  - site plans
  - building plans and elevations (as appropriate)
  - cross-sections
  - equipment layouts
  - structural drawings
  - mechanical drawings (HVAC, piping diagrams, etc.)
  - electrical drawings (service, distribution, interconnection, etc.)
- Preparation of contractual documents and bid solicitation packages
  - contract drawings
  - detailed specifications
  - contract clauses

- proposal formats
- submission instructions (date, time, place, fees, deposits, and bonding requirements)
- summary description of project
- acceptance/rejection stipulations
- type of proposed contract (e.g., lump sum, unit price, cost plus, etc.)
- project schedules
- contract award schedules
- contractor qualification criteria
- special conditions (labor, taxes, permits, liability responsibilities, hazardous or other anticipated special construction problems, etc.)
- conditions and schedules for payment

2.0 - 2.2 Advertising, Proposal Evaluation, and Construction Contract Award

- Decision on fully competitive or restricted bidding
- Selection of advertising media and timing of announcements
- Opening of bids and announcement
- Evaluation and determination of "lowest responsible" bidder (unless prequalification used)
  - bid conformance to stated bid criteria
  - satisfactory contractor resources, equipment, experience, sureties, etc.
- Formal notification of bid acceptance/rejection
- Contract execution

3.0 to 3.5 Construction Phase

- Issuance of subcontracts as appropriate
- Contractor development of shop drawings as required
- Approval of drawings by engineer as required
- Ordering of contractor-furnished equipment (CFE) and materials
- Initiation of construction
- Installation of CFE equipment as received
- Coordination for, or installation of, owner-furnished LLT equipment as appropriate
- Compliance with specified milestones and inspection points
- Submission of invoices for approval and payment.

4.0 - 4.1 Construction-and-Equipment-Installation-Supervision Phase

This responsibility is usually assigned to the design engineer. Activities include:

- Approval of contractor-developed "shop" drawings
- Inspection of work quality, materials, progress, and approval for certain work phases (e.g., inspection of reinforcing steel placement prior to concrete pouring), other field inspections to determine compliance with specifications and drawings, etc.
- Verification of progress for payment purposes
- Development of supplemental drawings and revisions as appropriate.

5.0 Utility Approval of Interconnection

If the cogeneration plant is to be interconnected with the power grid, in all probability, the concerned utility company will insist upon inspection and approval by their personnel of the interconnection equipment, wiring, controls, safety devices, and their operation prior to start-up for compliance with their previously-stipulated specifications and conditions.

6.0 - 6.1 Initial Operation and Check-Out

This phase involves a specified period for system check-out (in accordance with previously-developed procedures), system balancing, initial "shakedown" operation and operating procedure verification, personnel training, final inspections, and final system acceptance.

7.0 System-on-Line

System placed on-line and fully operational.

APPENDIX N

SUMMARY OF PRINCIPAL CODES AND STANDARDS

## APPENDIX N

### SUMMARY OF PRINCIPAL CODES AND STANDARDS

#### 1. Mechanical Design

##### American National Standards Institute

ANSI B1.1	Unified Screw Threads
ANSI B2.1	Pipe Threads (except dryseal)
ANSI B16.1	Cast-Iron-Pipe Flanges and Flanged Fittings
ANSI B16.5	Steel-Pipe Flanges and Flange Fittings
ANSI B16.9	Factory-Made Wrought-Steel Butt-Welding Fittings
ANSI B16.10	Face-to-Face and End-to-End Dimension of Ferrous Valves
ANSI B16.34	Steel Butt-Welding End Valves
ANSI B16.11	Forged Steel Fittings
ANSI B16.25	Butt-Welding Ends
ANSI B31.1.0	Power Piping
ANSI S1.2	Physical Measurement of Sound
ANSI S1.13	Sound Pressure Levels

##### American Petroleum Institute

API-650	"Welded Steel Tanks"
---------	----------------------

##### Air Conditioning and Refrigeration Institute

ARI 410-72	Standard for Forced-Circulation Air Cooling and Air Heating
------------	---

##### American Society of Heating, Refrigeration, and Air-Conditioning Engineers

ASHRAE Guide and Data Book - Systems
ASHRAE Guide and Data Book - Applications
ASHRAE Guide and Data Book - Fundamentals
ASHRAE Guide and Data Book - Equipment
ASHRAE Guide - USAEC Health and Safety Bulletin No. 212

##### American Society of Mechanical Engineers, Boiler and Pressure Vessel Code

Sect I	ASME B&PV Code, Power Boilers
Sect II, Part A	ASME B&PV Code, Material Specification, Ferrous
Sect II, Part C	ASME B&PV Code, Material Specification, Welding Rods, Electrodes and Filler Materials
Sect V	ASME B&PV Code, Non-Destructive Examination
Sect VIII, Div 1	ASME B&PV Code, Pressure Vessels
Sect VIII, Div 2	ASME B&PV Code, Pressure Vessels, Alternative Rules
Sect IX	ASME B&PV Code, Welding Qualifications

##### American Society of Testing and Materials (ASTM)

##### Heat Exchange Institute

Standards for Closed Feedwater Heaters
Standards for Steam Surface Condensers
Standards for Deaerators
Standards for Steam Jet Ejectors

##### Standards for Tubular Exchangers Manufacturers Association (TEMA)

##### The Hydraulic Institute Standards

Manufacturers Standardization Society

- SP-6 Standard Finishes for Contact Faces of Pipe Flanges and Connecting-End Flanges of Valves and Fittings
- SP-61 Hydrostatic Testing Steel Valves

National Fire Protection Association

National Fire Codes (Latest Edition)

Occupational Safety and Health Standards (OSHA)

Pipe Fabrication Institute Standards

Sheet Metal and Air-Conditioning Contractors National Association

Underwriters Laboratories (UL) Requirements

Factory Mutual (FM) Requirement

2. Structural Design

A. General

Uniform Building Code and Uniform Building Code Standards, 1982 Edition (UBC).

Occupational Safety and Health Act, 1970 (OSHA).

B. Concrete

Building Code Requirements for Reinforced Concrete - ACI 318-77.

C. Structural and Miscellaneous Steel

AISC Specification for the Design, Fabrication and Erection of Structural Steel for Buildings, 8th Edition, 1980 (or latest issue).

AISC Specification for Structural Joints using ASTM A 325 or A 490 Bolts, April 1978.

D. Welding

American Welding Society Structural Welding Code AWS D1.1-79.  
American Welding Society Reinforcing Steel Welding Code AWS 12.1-75.

3. Electrical Design

National Electric Code

Applicable State Building Standards

Regulations of the National Board of Underwriters for Electric Wiring and Apparatus

National Electric Manufacturers Association (NEMA)

Safety and Occupational Health Administration (OSHA)

Institute of Electrical and Electronic Engineers (IEEE)

American National Standards Institute (ANSI)

Insulated Power Cables Engineers Association (IPCEA)

National Fire Protection Association

## APPENDIX O

### PROJECT CHECK-LIST

1. Site Survey and Preparation
  - A. Test borings
  - B. Clearing, grubbing, and disposal
  - C. Filling and grading
  - D. Drainage ditching
  - E. Temporary roads.
2. Subsurface Earth Stabilization and Reinforcement
  - A. Piers as required
  - B. Pilings as required.
3. Concrete Foundations and Structures
  - A. Plant building foundations
  - B. Turbine/generator foundations
  - C. Stack foundation
  - D. Flue-gas scrubber and baghouse-filter foundations
  - E. Primary fuel-handling structures and foundations
  - F. Secondary fuel-handling structures and foundations
  - G. Residue-handling structures and foundations
  - H. Auxiliary-equipment bases
  - I. Electrical manholes and ductbank
  - J. Drainage manholes.
4. Plant Building
  - A. Structural steel
  - B. Grating and handrail
  - C. Siding
  - D. Roofing
  - E. Fenestration
  - F. Elevator
  - G. Suspended slabs
  - H. Interior partition walls, doors, ceilings
  - I. Interior floor coverings and separate finishes
5. Plant Service Systems
  - A. Roads and parking
  - B. Railroad
  - C. Storm drainage and sewers
  - D. Sanitary drains and sewers
  - E. Floor and roof drains
  - F. Fencing and gates
  - G. Service air
  - H. Potable water
  - I. Fire protection water
  - J. Lighting
  - K. Heating
  - L. Ventilation
  - M. Air conditioning
  - N. Central vacuum cleaning
  - O. Dust collecting
  - P. Telephone
  - Q. Intercommunications
  - R. Office
  - S. Locker rooms (lockers, showers, toilets, lavatories, wash basins, and water heater)



- T. Drinking fountains
- U. Machine shop
- V. Storage room
- W. Cranes and hoists
- X. Fire protection
- Y. Cathodic protection
- Z. Electrical grounding.

6. External Utility Systems

- A. Process steam
- B. HVAC system
- C. Condensate return
- D. Potable and fire-protection water
- E. Storm sewer
- F. Sanitary sewer
- G. 13.8 kV electrical power supply
- H. Telephone

7. Energy-Conversion Equipment

- A. Steam generators
- B. Turbine generators.

8. Energy-Conversion Process Support Systems

- A. Plant auxiliary electrical service
- B. Plant battery and charger
- C. Emergency AC supply
- D. Instrument air
- E. Demineralized water supply and storage
- F. Auxiliary equipment cooling water.

9. Energy-Conversion Process Supervisory Systems

- A. Control room
- B. Combustion and feedwater control
- C. Turbine generator supervisory
- D. Generator control
- E. Turbine/generator relaying and metering
- F. Auxiliary equipment motor control
- G. Steam and water sampling and laboratory
- H. Fuel sampling
- I. Stack-gas effluent monitoring

10. Boiler and Turbine/Generator Subsystems

- A. Fans
- B. Flue-gas-desulfurization scrubber
- C. Baghouse filter
- D. Stack
- E. Soot blowers
- F. Primary fuel-handling and storage
- G. Secondary fuel-handling, storage, and preparation
- H. Residue-handling and storage
- I. Deaerator
- J. Feedwater heaters
- K. Boiler feed pumps
- L. Condensate pumps
- M. Miscellaneous pumps
- N. Chemical feed pumps and storage
- O. Auxiliary equipment motors
- P. Condensate storage
- Q. Blowdown tank and heat exchanger
- R. Blowoff tank
- S. Turbine/generator lube oil supply

- T. Turbine/generator lube oil storage
- U. Turbine/generator lube oil conditioning
- V. Generator excitation
- W. Generator neutral grounding
- X. Generator surge protection

#### 11. Piping Systems

- A. High-pressure, high-temperature steam
- B. Turbine exhaust steam
- C. Process and HVAC steam
- D. Boiler feedwater
- E. Condensate
- F. Condensate return
- G. Potable water
- H. Demineralized water
- I. Fire-protection water
- J. Chemical feed
- K. Instrument air
- L. Service air
- M. Auxiliary equipment cooling water
- N. Drainage
- O. Atmospheric vents
- P. Vacuum cleaning
- Q. Dust collecting
- R. Pneumatic conveyor air

#### 12. Piping Materials

- A. Fabricated piping
- B. Miscellaneous piping
- C. Piping supports
- D. Valves
- E. Piping accessory equipment
- F. Piping and equipment insulation and lagging

#### 13. Cable Systems

- A. Generator voltage leads
- B. Power and control cable
- C. Lighting and control cable
- D. Instrument wiring
- E. Cable tray and conduit
- F. Junction boxes
- G. Starters and contactors
- H. Pushbutton stations
- I. Wiring and cable accessory equipment

#### 14. Plant Clean-up and Preparation

- A. Painting
- B. Final grading
- C. Landscaping
- D. Seeding
- E. Miscellaneous

#### 15. Vehicles

- A. Plant vehicles

**UNITED STATES  
DEPARTMENT OF ENERGY  
WASHINGTON, D.C. 20585**

OFFICIAL BUSINESS  
PENALTY FOR PRIVATE USE, \$300

POSTAGE AND FEES PAID  
U.S. DEPARTMENT OF ENERGY  
DOE 350



**FIRST CLASS MAIL**