



**Molten Salt Solar Electric Experiment**  
Testing, Operation and Evaluation

---

Research Project 2302-2

Volume 2, Addenda

March 1987

Prepared by

McDonnell Douglas Astronautics Company  
5301 Bolsa Avenue  
Huntington Beach, California 92647

Principal Investigator  
R. J. Holl

Contributors  
D. R. Barron  
S. A. Saloff

Prepared for

Electric Power Research Institute  
3412 Hillview Avenue  
Palo Alto, California 94304

EPRI Project Manager  
E. A. DeMeo

Solar Power Systems Program  
Advanced Power Systems Division

---

MOLTEN SALT ELECTRIC EXPERIMENT (MSEE)

Volume 2

ADDENDA

---

Submitted by

McDonnell Douglas Astronautics Company  
Huntington Beach, California  
Under EPRI Contract No. RP2302-2

## PREFACE

This final report of the Molten Salt Electric Experiment (MSEE) is submitted by McDonnell Douglas Astronautics Company to Electric Power Research Institute in accordance with the provisions of EPRI contract No. RP2302-2. This report consists of the following volumes:

Volume 1, MSEE Testing, Operator Training and System Evaluation

Volume 2, Addenda

Volume 1 presents the detailed testing/training program and the evaluation of results with predicted performance. It also describes in detail each subsystem and presents a complete listing of conclusions and recommendations. Finally, the overall technology assessment is presented.

Volume 2 is a compilation of various important documents related to the MSEE. These include:

1. Phase II Test Plan (Addendum A)
2. Test Procedures (Addendum B)
3. Test Data (Addendum C)
4. Test Conductor's Daily Log (Addendum D)
5. Reliability Audit Report (Addendum E)
6. Master Control Subsystem Display (Addendum F)
7. Turbine-Generator Failure (Addendum H)

## CONTENTS

Addendum A	MSEE Phase II Test Plan	A-1
Addendum B	Test Procedures	B-1
Addendum C	Test Data	C-1
Addendum D	Test Conductor's Daily Log	D-1
Addendum E	Reliability Audit Report	E-1
Addendum F	Master Control Subsystem Display	F-1
Addendum G	Receiver Freeze/Thaw Report	G-1
Addendum H	Turbine-Generator Failure	H-1

Addendum A  
MSEE PHASE II TEST PLAN

Molten Salt Electric Experiment

Phase II Test Plan

April 30, 1984

## FOREWORD

This Phase II Test Plan is one of three documents that describe plans for Phase II of the MSEE project. These documents are:

### MSEE Evaluation Plan

Plan to accomplish MSEE project objectives using Phase I and Phase II Test results, analysis and evaluation.

### Phase II Test Plan

Plan for tests during Phase II which will provide data needed for evaluation.

### Operator Training Plan

Plan to train four teams of utility operators and obtain their feedback on the MSEE system.

## TABLE OF CONTENTS

	<u>Page</u>
Section 1 INTRODUCTION	A-9
1.1 BACKGROUND	A-9
1.2 SCOPE	A-10
1.3 APPROACH	A-10
1.4 PHASE II SCHEDULE	A-11
1.5 RELATED DOCUMENTATION	A-11
Section 2 MSEE PROJECT OBJECTIVES	A-13
Section 3 MSEE SYSTEM DESCRIPTION	A-15
3.1 COLLECTOR SUBSYSTEM	A-18
3.2 RECEIVER SUBSYSTEM	A-20
3.3 THERMAL STORAGE SUBSYSTEM	A-22
3.4 STEAM GENERATION SUBSYSTEM	A-24
3.5 ELECTRIC POWER GENERATION SUBSYSTEM	A-24
3.6 HEAT REJECTION & FEEDWATER SUBSYSTEM	A-27
3.7 MASTER CONTROL	A-30
3.8 DATA ACQUISITION SUBSYSTEM	A-34
Section 4 PHASE II ROLES AND RESPONSIBILITIES	A-35
4.1 PHASE II CONTRACT MANAGER	A-35
4.2 MSEE PROJECT MANAGER	A-35
4.3 SITE MANAGER	A-35
4.4 MSEE PHASE I SYSTEMS INTEGRATOR	A-36
4.5 TECHNICAL COMMITTEE	A-36
4.6 EQUIPMENT SUPPLIERS	A-37
4.7 HOST UTILITY	A-37
4.8 UTILITY SPONSORS	A-37
4.9 MCDONNELL DOUGLAS ASTRONAUTICS COMPANY (MDAC)	A-37



	<u>Page</u>
Section 5 TEST PROGRAM DESCRIPTION	A-39
5.1 GENERAL	A-39
5.2 TEST II-1 - RECEIVER LOOP PERFORMANCE	A-46
5.3 TEST II-2 - POWER PRODUCTION SUBSYSTEMS PERFORMANCE	A-50
5.4 TEST II-3 - TRANSIENT RESPONSE OF RECEIVER LOOP	A-53
5.5 TEST II-4 - OVERNIGHT THERMAL CONDITIONING OF FILLED RECEIVER	A-57
5.6 TEST II-5 - OVERNIGHT HOLD CONDITIONS FOR SGS	A-59
5.7 TEST II-6 - OPTIMUM OPERATING STRATEGY DEVELOPMENT	A-61
5.8 TEST II-7 - RECEIVER COLD FLOW	A-63
5.9 TEST II-8 - RECEIVER STEADY STATE OPERATION	A-65
5.10 TEST II-9 - RECEIVER OPERATION WITH SIMULATED (SLOW) CLOUD	A-68
5.11 TEST II-10 - THERMAL STORAGE CHARGING WITH PROPANE HEATER	A-71
5.12 TEST II-11 - STEAM GENERATOR AND HRFS STEADY STATE OPERATIONS	A-74
5.13 TEST II-12 - OPERATION OF FULL ELECTRIC LOOP	A-75
5.14 TEST II-13 - SYSTEM STEADY STATE OPERATION	A-78
5.15 TEST II-14 - HYBRID OPERATION	A-81
5.16 TEST II-15 - SALT PROPERTIES AND STABILITY	A-84
5.17 TEST II-16 - SALT CORROSION	A-85
Section 6 SCHEDULE AND PRIORITIES	A-87
Section 7 TEST DOCUMENTATION	A-89

## SECTION 1 INTRODUCTION

### 1.1 BACKGROUND

Solar thermal central receiver systems have been under development since the early seventies. The first central receiver systems used water/steam as a heat transfer fluid in the receiver. Subsequent studies and test programs investigated molten salt, liquid sodium, and hot air as heat transfer fluids. They all possess certain advantages over water/steam, but many feel that molten nitrate salt is the most promising heat transfer fluid, particularly for utility-scale electric power plants with thermal storage.

A complete molten salt system experiment has been built at the Department of Energy (DOE) Central Receiver Test Facility (CRTF) located at Kirtland Air Force Base, Albuquerque, New Mexico. Two of the subsystems, the receiver and the thermal storage unit, have already been built and tested as subsystem research experiments, although the salt loop from the storage tanks to the receiver, consisting of a new boost pump, approximately 400 ft. of piping, valves, surge tanks and supporting instrumentation and control, is all new hardware. The tower and heliostat field are already available to concentrate solar energy onto the receiver. A molten salt steam generator has been designed and built specifically for this experiment. A 750 kW<sub>e</sub> turbine/generator has been installed to convert thermal energy to electricity. This electricity will be fed into the local power grid. The heat rejection subsystem is part of the CRTF and has been used in previous test programs. The master control subsystem for the complete experiment is new.

This experiment is being conducted in two phases. Phase I, nearing completion, is a design, construction, installation, checkout, and verification effort. In Phase II, system characterization tests will be performed and the system will be operated and evaluated by utility personnel. The system, either as-is or modified to more closely simulate utility plants, may be run for an additional period in a potential third phase.

A consortium consisting of utilities, industries and the Electric Power Research Institute (EPRI), has helped construct and will support operation of the experiment. The consortium is supplying half of the project's funding through either cash contributions or donations of in-kind engineering services. The other half is supplied by the DOE, through Sandia, including engineering, experiment hardware, on-site labor and facility hardware.

## 1.2 SCOPE

The scope of this document is to define the specific tests to be conducted during Phase II. Each test is briefly described including the specific test objectives, test conditions, test sequence, the criteria for success and data requirements.

## 1.3 APPROACH

The Phase II test program is designed to provide the test information and operating opportunities to fulfill all major project objectives.

It is assumed that: (1) the Phase I test program has been completed at the initiation of Phase II; (2) all operating procedures required in Phase II have been written and verified during Phase I; and (3) CRTF personnel have been fully trained in operation of MSEE.

This plan is structured to sequentially develop engineering test results for MSEE evaluation and then provide training and operation of the MSEE by up to four teams of utility operators. The initial series of Phase II tests will thoroughly characterize the operation and performance of the MSEE including off-design conditions and operation through insolation transients. System integrity during transient tests with increasing power will be assured through: (1) controlling the receiver outlet temperature at less than the design value (1050°F), (2) limiting the magnitude of the power increase, and (3) limiting the ramp rate. These limitations will be relaxed in successive tests, as indicated by test results, to determine the maximum sun-following capability of the system. Alternative overnight hold conditions will be tested to determine the most efficient mode and to help assess the value of a receiver door.

The results of the foregoing characterization of system operation and performance will be used to develop and verify an optimum operating strategy for the MSEE and to define system characteristics which would lead to improved operational availability and overall efficiency. The improved operating strategy/strategies will be demonstrated by the utility teams during their operation of the MSEE.

#### 1.4 PHASE II SCHEDULE

The Phase II test program will begin upon completion of Phase I which is expected to occur about May 11, 1984. The engineering tests are scheduled to be completed by August 3, 1984. Training and operation by utility operators is planned to extend until about November 16, 1984.

#### 1.5 RELATED DOCUMENTATION

The following documents are related to this Test Plan and the MSEE environment.

<u>Number</u>	<u>Title</u>
MCR-83-514	MSEE Configuration Management Plan
MCR-83-515	MSEE Phase I Test Plan
MCR-83-531	MSEE Hazards Analysis
MCR-83-538	MSEE Master Control Subsystem Requirements Specification
MCR-83-539	MSEE Steam Generator Subsystem Interface Control Document
MCR-83-541	MSEE System Specification
MCR-83-542	MSEE Receiver Subsystem Interface Control Document
MCR-83-543	MSEE Thermal Storage Subsystem Interface Control Document
MCR-83-544	MSEE Heat Rejection and Feedwater Subsystem Interface Control Document
MCR-83-545	MSEE Electric Power Generation Subsystem Interface Control Document
MCR-83-546	MSEE System Test Procedure
MCR-83-547	MSEE Receiver Testing Integrated Test Procedure
MCR-83-548	MSEE Steam Generation Acceptance Testing Integrated Test Procedure
MCR-83-549	MSEE Electric Power Generation Testing Integrated Test Procedure
MCR-83-550	MSEE Special Procurement List
MCR-83-551	MSEE Failure Modes and Effects Analysis
	MSEE Phase II Training Plan
	MSEE Phase II Evaluation Plan

## Section 2

### MSEE PROJECT OBJECTIVES

The overall objective of the MSEE program is to verify the system design, demonstrate its operation under all anticipated modes, characterize the system, and train utility operators to operate the system. The following objectives and goals were developed by the MSEE Technical Committee.

#### Phase II General Objectives:

- a) Obtain, evaluate, and document performance data for each subsystem and total system interaction sufficient to verify design and identify uncertainties.
- b) Define the operating range, flexibility and limitations of the system as installed.
- c) Document performance results and evaluations that may be used for scaleup.
- d) Identify and prioritize areas that need additional development.
- e) Verify that equipment protection system functions properly in all modes of operation.

#### Specific Phase II Goals:

- a) Demonstrate system performance:
  - (1) Design operating conditions for all subsystems
  - (2) Design control concept and subsystem interaction
  - (3) Overall performance efficiency
- b) Determine the response of the system to deviations (transients) from design conditions:
  - (1) Naturally occurring including clouds and unanticipated outages.
  - (2) Controlled to determine limits (cold and hot start-ups, shutdowns, etc.)
- c) Develop the appropriate operating strategies to maximize solar energy utilization.

- d) Collect thermal/hydraulic and thermal/mechanical design data to support design assumptions and to determine acceptable heat-up and cooldown rates.
- e) Provide data to determine the mechanical reliability of individual components as used by:
  - (1) Regular inspections (visual and non-destructive)
  - (2) Post-failure examination
  - (3) Provide input to a plan for post Phase II inspections of critical components for corrosion, erosion, cracking, etc.
- f) Provide data to compare analytical and operational data and update the control models and the systems model where required.
- g) Document results and actions via:
  - (1) Interim quarterly presentations covering results, conclusions and action plans.
  - (2) Final Phase II MSEE report

This test plan is designed to provide the test data necessary to accomplish these objectives and goals. Prioritization of the tests, hence goals and objectives, is given in Section 6.

### Section 3 MSEE SYSTEM DESCRIPTION

The MSEE system is shown as an artist's concept in Figure 3.1. It is designed to demonstrate the conversion of solar energy to electricity using molten salt and water/steam as the working fluids. The molten salt is the energy transfer medium from the receiver through thermal storage to the steam generation subsystem and water/steam is the energy transfer medium from the steam generation subsystem to the electric power generation subsystem. The system schematic is shown in Figure 3.2. The receiver, located at the top of the CRTF tower, receives concentrated solar energy from the collector field. Molten salt from the cold storage tank, located at ground level, is pumped up the tower piping and through the receiver. In the experiment, cold salt is nominally defined to have a temperature of 306<sup>o</sup>C (580<sup>o</sup>F). The salt is heated from 310<sup>o</sup>C to 566<sup>o</sup>C (590<sup>o</sup>F to 1050<sup>o</sup>F) in the receiver, flows through a downcomer, and is throttled into the hot salt storage tank. Hot salt is defined to have a nominal temperature of 566<sup>o</sup>C (1050<sup>o</sup>F). Hot salt from storage is pumped through the steam generator superheater and evaporator, and is returned to the cold storage tank. An additional flow of cold salt is injected in the salt line between the superheater and evaporator to reduce the salt temperature entering the evaporator; this is to allow the use of low alloy steel in the evaporator. Main steam from the steam generator is used to drive a conventional steam turbine-generator. There are two principal advantages of this molten salt receiver system over a water/steam receiver system: the steam generator and turbine are decoupled from the receiver by the thermal storage subsystem; and, molten salt from the receiver is used directly as the thermal storage fluid, thus providing an inexpensive source of thermal storage and a constant temperature heat source for the steam generator.

The system is divided into the following subsystems:

- a) Collector (CS)
- b) Receiver (RS)
- c) Thermal Storage (TSS)
- d) Steam Generation (SGS)
- e) Electric Power Generation (EPGS)
- f) Heat Rejection and Feedwater (HRFS)
- g) Master Control (MCS)
- h) Data Acquisition (DAS)



FIGURE 3.1 Artists Concept

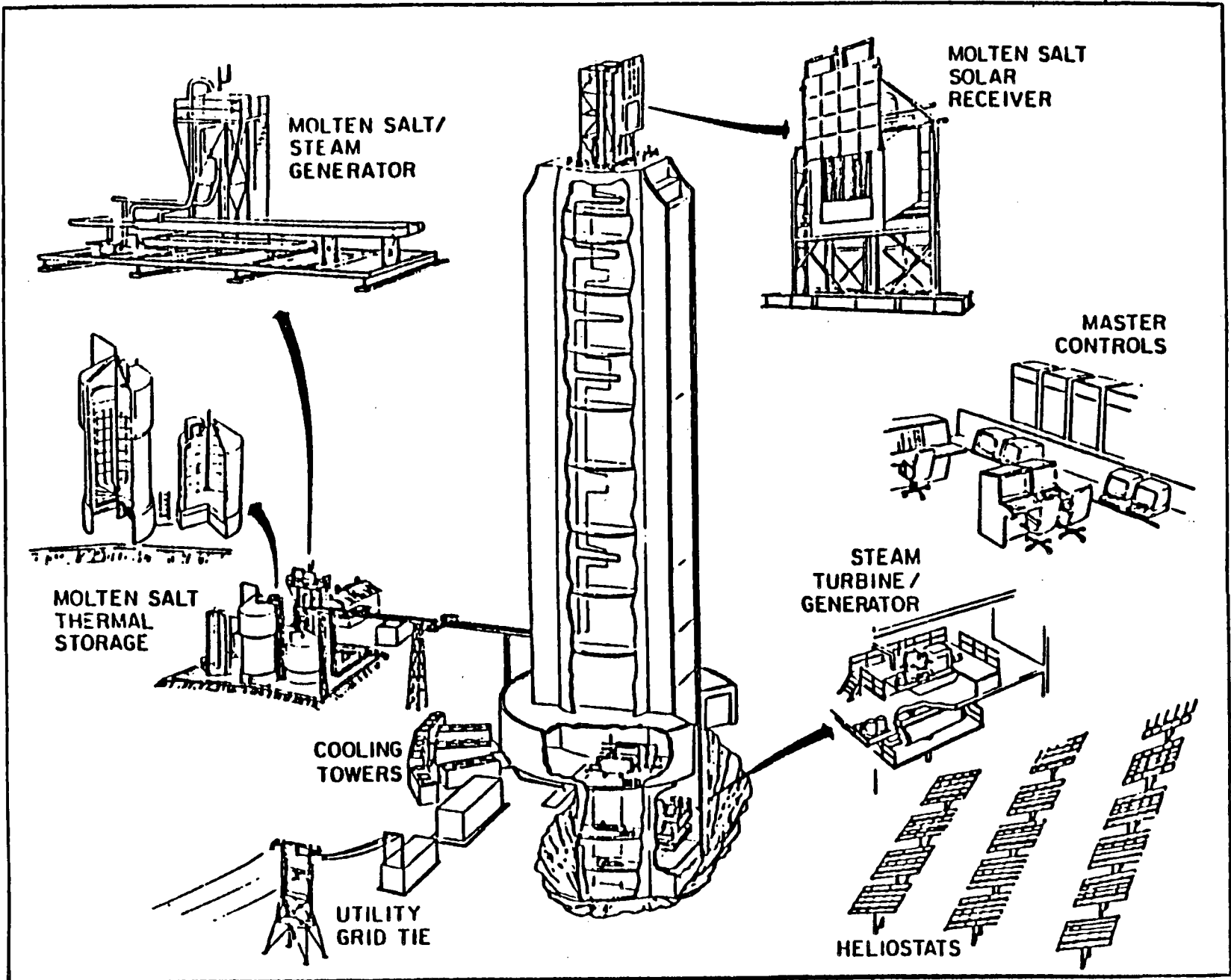

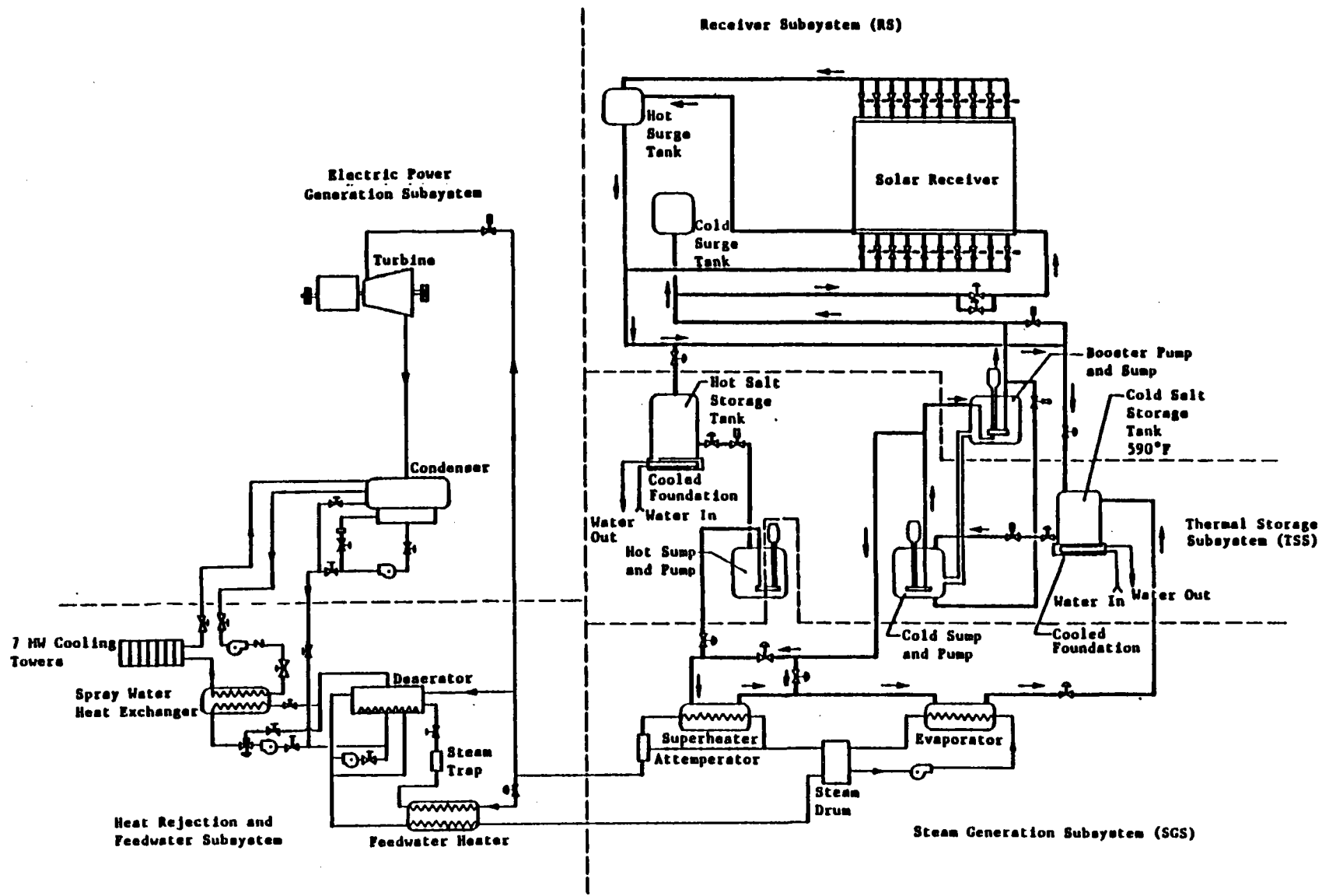

FIGURE 3.2 MSEE Flow Schematic

A tabulation of data describing the MSEE system is given on Table 3.1. A more detailed description of the MSEE subsystems is contained in the following subsections.

### 3.1 COLLECTOR SUBSYSTEM

The collector subsystem redirects, concentrates, and focuses solar radiation onto the tower-mounted receiver. The subsystem, which is already in place at the CRTF, consists of 221 two-axis tracking heliostats located north of the receiver tower, and its control system. Under optimum insolation and heliostat conditions, the heliostat field can concentrate approximately 5  $MW_t$  onto the receiver.

Each heliostat has 25 individual mirror facets totaling  $37.2 \text{ m}^2$  ( $400 \text{ ft}^2$ ) of reflective surface. The facets are mounted on a structure and individually adjusted to provide a concentration ratio of 25 to 1 on the receiver. The structure has motor-driven azimuth and elevation gimbals, which allow it to track the sun during the day.

The heliostats are operated from the control room by the CRTF collector control system. (The CRTF collector control system will be separate from the experiment master control subsystem.) The CRTF collector control system analyzes heliostat operating commands from a number of programmed test sequences or from the facility heliostat operator. Control signals are distributed to the heliostats through four heliostat array controllers and four heliostat interface modules. Each heliostat receives azimuth and elevation pointing information once every second and responds with its own status. Commands and data transmitted to the individual heliostats are received and executed by the heliostat control electronics. The electronics keep the drive motor power at the proper level until the gimbal axis encoders indicate that the desired position has been reached.

Table 3.1

MSEE Data

- Location -- CRTF; on Kirtland Air Force Base, Albuquerque, NM
- Heliostat Field -- Existing field of 221 heliostats each with 400 ft<sup>2</sup> of mirror surface.
- Tower -- Existing concrete tower, 200 ft. high with internal lifting module
- Master control -- EMCON D-2 distributed digital control system with central consoles; separate equipment protection system.
- Receiver -- Refurbished from previous Subsystem Research Experiment.
- o Rating: 5 MW<sub>th</sub>
  - o Salt temperatures: in - 590<sup>o</sup>F; out - 1050<sup>o</sup>F
  - o Configuration: cavity with door
  - o Absorber: single panel of 3/4 in Incoloy 800 tubes (18 passes, 16 tubes per pass)
  - o Peak flux: 630 kW/m<sup>2</sup> (200,000 Btu/hr - ft<sup>2</sup>)
- Thermal Storage -- Existing from previous Subsystem Research Experiment
- o Rating: 6.54 MW<sub>th</sub> Hr when operating between 590<sup>o</sup>F and 1050<sup>o</sup>F
  - o Type: 2-tank
    - Hot tank, internal insulation
    - Cold tank, external insulation
- Steam Generator -- Supplied by Babcock and Wilcox
- o Type: Forced recirculation
  - o 2 units: evaporator and superheater (both U-tube, U-shell) with steam drum separator
  - o Rating: 11,000 lb/hr of steam at 940<sup>o</sup>F and 1100 psi (3.13 MW<sub>th</sub>)
  - o Prototypical of commercial design
- Turbine Generator -- GE rebuilt unit
- o Marine turbine
  - o 750 kW<sub>e</sub> rating
- Heat Rejection and Feedwater System -- existing at CRTF
- o Feedwater treatment only
  - o 20,000 gallon demineralized water storage
  - o Dry cooling, 7 MW<sub>th</sub> capacity

### 3.2 RECEIVER SUBSYSTEM

The receiver subsystem (Figure 3.3) captures the insolation redirected from the heliostat field and converts it to thermal energy in the molten salt. The subsystem consists of the receiver absorber panel, cavity enclosure with one vertical aperture door, insulation, heat tracing, cold surge tank, booster pump, hot surge tank, overflow tank, instrumentation, and control valves. The receiver is located at the top of the CRTF tower.

The receiver was tested in a previous subsystem research experiment. Since the initial experiment, the receiver has been refurbished. This refurbishment included instrumentation and control system modifications, minor structural and piping changes, and the replacement of the two original horizontal cavity doors with one vertical aperture door.

The receiver absorber is a single panel with 18 vertical passes having 16 tubes per pass. The tubes are Incoloy 800 with 19 mm (0.75 in.) outside diameter. Purge and drain valves are provided for each pair of passes.

The receiver surge tanks are designed to dampen changes in the salt flow rate and to maintain salt flow through the receiver in the event of a cold salt pump outage. The cold surge tank is pressurized with facility-supplied instrument air to supply the necessary head to force the salt through the receiver in the event of a pump outage, and to provide a surge volume within the tank. The hot surge tank operates at atmospheric pressure, and is vented to an adjacent overflow tank in the event of a control problem in the salt downcomer throttle valve.

The cold salt booster pump takes its suction from the discharge of the cold salt pump and provides the necessary head for the salt as it travels up the tower and through the receiver.

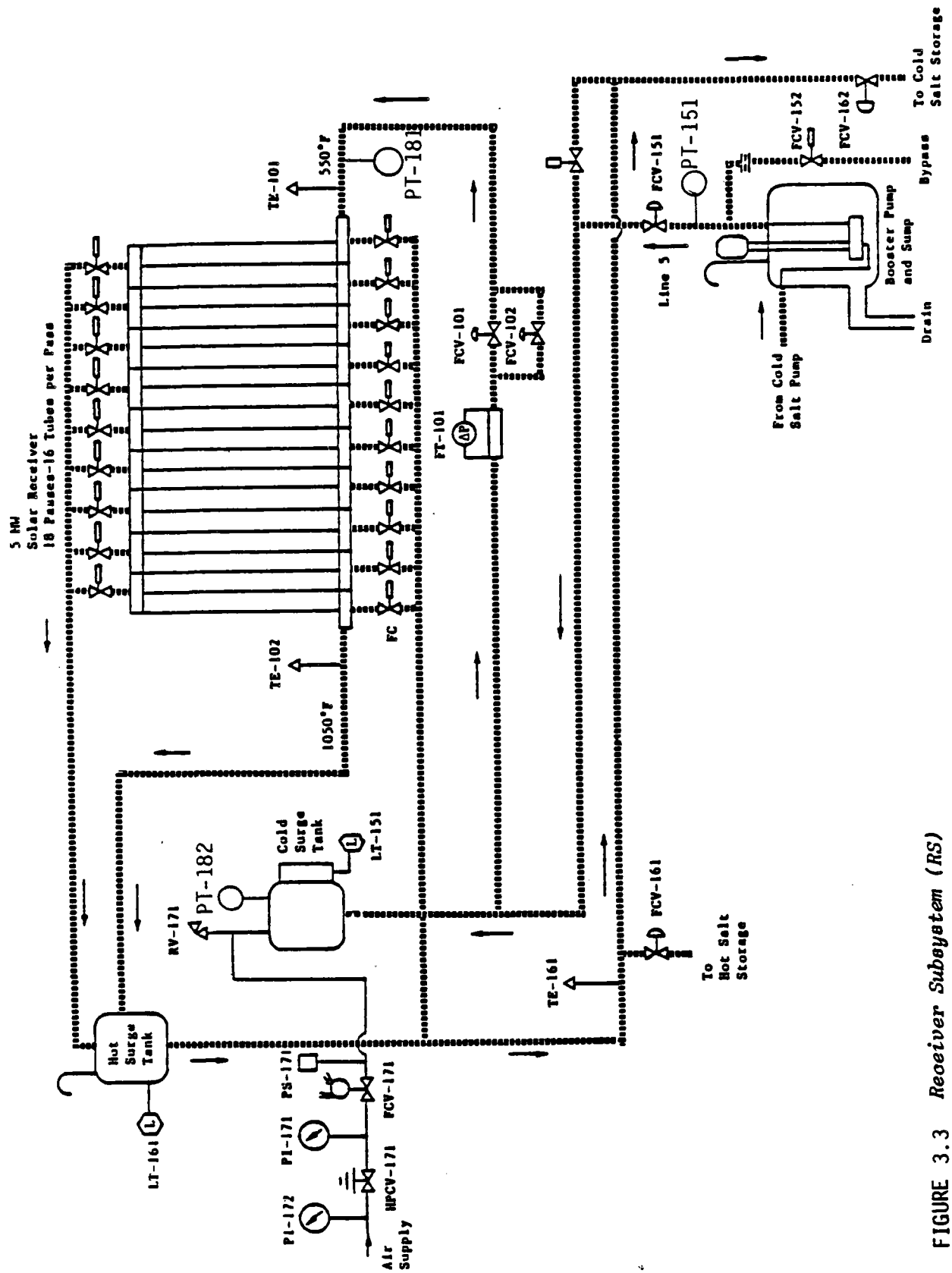

FIGURE 3.3 Receiver Subsystem (RS)

The cold salt line to the receiver starts at the booster pump, rises to the top of the hot storage tank, traverses the distance from the storage tanks to the receiver tower on an elevated pipe bridge, enters the tower, and runs up the east side of the tower in an existing pipe chase to the receiver. The hot salt line leaves the hot surge tank and traverses to the pipe chase. The hot salt downcomer carries the salt to the level of the pipe bridge. The hot salt line traverses the bridge, ending in a control valve which throttles the flow to the hot storage tank. The salt piping is inclined between the storage tanks and the tower to ensure that the piping system will completely drain. The salt piping is electrically heat traced and insulated with calcium silicate and aluminum sheathing.

### 3.3 THERMAL STORAGE SUBSYSTEM

The thermal storage subsystem provides a cold salt source for the receiver for daytime operation, and a hot salt source for the steam generator for day and early evening operation. The TSS can also furnish a source of thermal energy for overnight freeze protection of the receiver, steam generator, and salt piping and for early morning plant start-up. The subsystem includes the hot and cold salt storage tanks, propane-fired salt heater, cold salt pump and cold salt sump. The subsystem schematic is shown on Figure 3.4.

The salt pump is of a vertical cantilever design. The impeller and casing are suspended below the liquid level in a sump; the bearings are located above the liquid level and do not contact the salt.

The hot salt tank employs a unique design. To allow the use of carbon steel in the structural portions of the tank, an internal refractory insulation is used to limit the temperature of the walls, roof, and floor. A waffled Incoloy liner separates the salt and the internal insulation, and the tank foundation is cooled with circulating water to limit the floor temperature. The outside of the tank is insulated in the conventional manner with calcium silicate and aluminum sheathing. The cold salt tank is similar in design to the hot tank except that it does not require the internal insulation and liner due to its lower operating temperature. During the previous subsystem research experiment testing, the hot and cold tanks experienced only a limited number of temperature cycles.

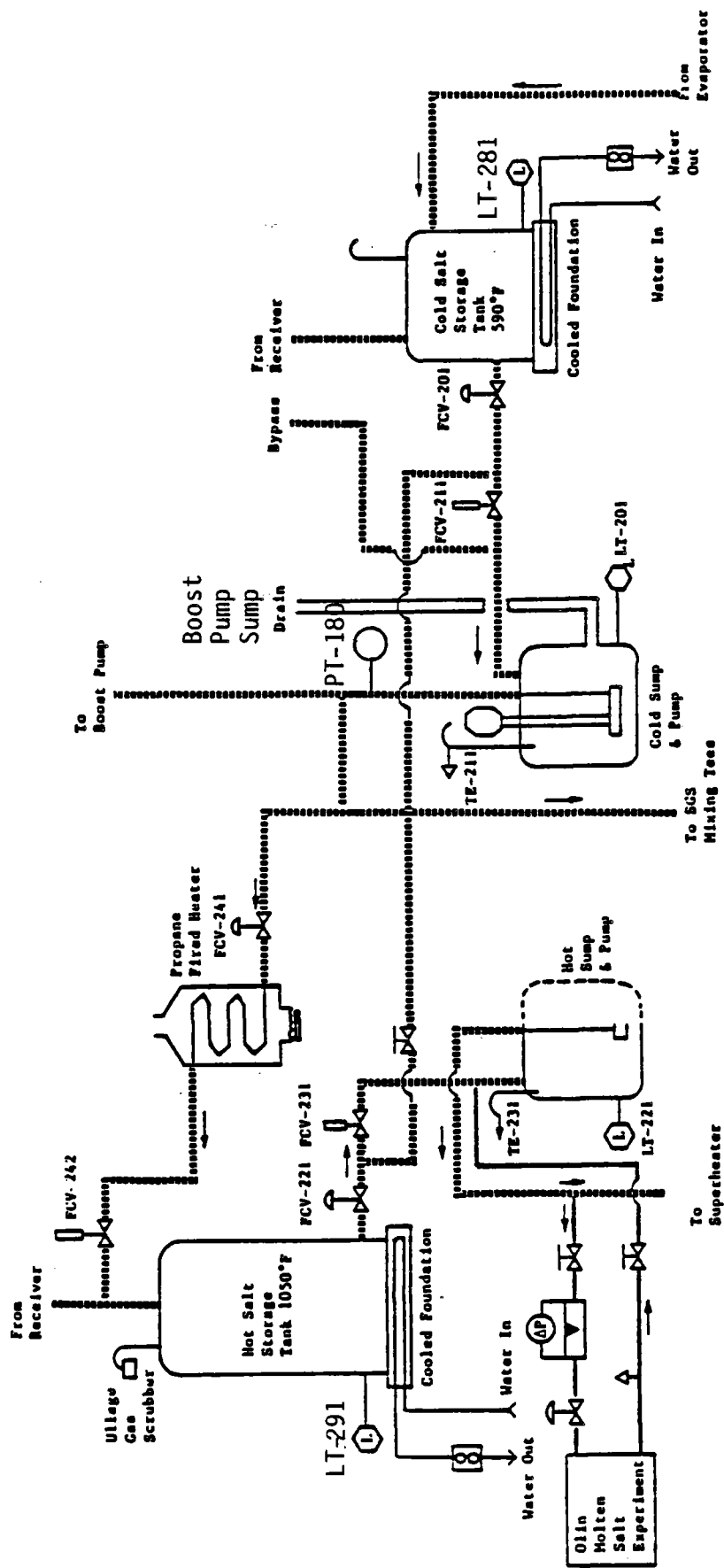

FIGURE 3.4 Thermal Storage Subsystem (TSS)



### 3.4 STEAM GENERATION SUBSYSTEM

The steam generation subsystem transfers sensible heat from the molten salt to produce superheated steam for the turbine-generator. The subsystem schematic is shown on Figure 3.5. The subsystem includes an evaporator, steam drum, boiler recirculation pump, superheater, and attemperator. The steam generator is the only major item of molten salt equipment which has not been tested in a subsystem research experiment.

The evaporator and superheater are U-tubes, U-shell heat exchangers, with low pressure salt on the shell side and high-pressure water and steam on the tube side. This shell and tube configuration has been selected to minimize thermal stresses, due to differential expansion, in the tubes and tubesheets.

A conventional steam drum, located above the evaporator, separates water droplets from the saturated steam before the latter enters the superheater, and receives feedwater from the feedwater heater. A forced recirculation design was selected, since it is preferred for power plants requiring daily start-up and shutdown.

The turbine requires a main steam temperature of  $504^{\circ}\text{C}$  ( $940^{\circ}\text{F}$ ); the steam outlet temperature from the superheater has been specified as  $538^{\circ}\text{C}$  ( $1000^{\circ}\text{F}$ ). The superheater outlet steam is attemperated by mixing with a small amount of saturated steam from the drum. The salt flow from the superheater to the evaporator is also attemperated, from  $486^{\circ}\text{C}$  ( $906^{\circ}\text{F}$ ) to  $454^{\circ}\text{C}$  ( $850^{\circ}\text{F}$ ), by mixing with salt flow from the cold tank. This allows chrome-moly piping and fittings, rather than stainless steel, to be used in the evaporator.

Warmup of the steam generation subsystem is accomplished by isolating the subsystem and preheating with the subsystem's electrical heater.

### 3.5 ELECTRIC POWER GENERATION SUBSYSTEM

The electric power generation subsystem converts the enthalpy in the main steam flow to electricity. The subsystem (Figure 3.6) includes the steam turbine, electric generator, electric power equipment, condenser, condensate pump and storage tank.

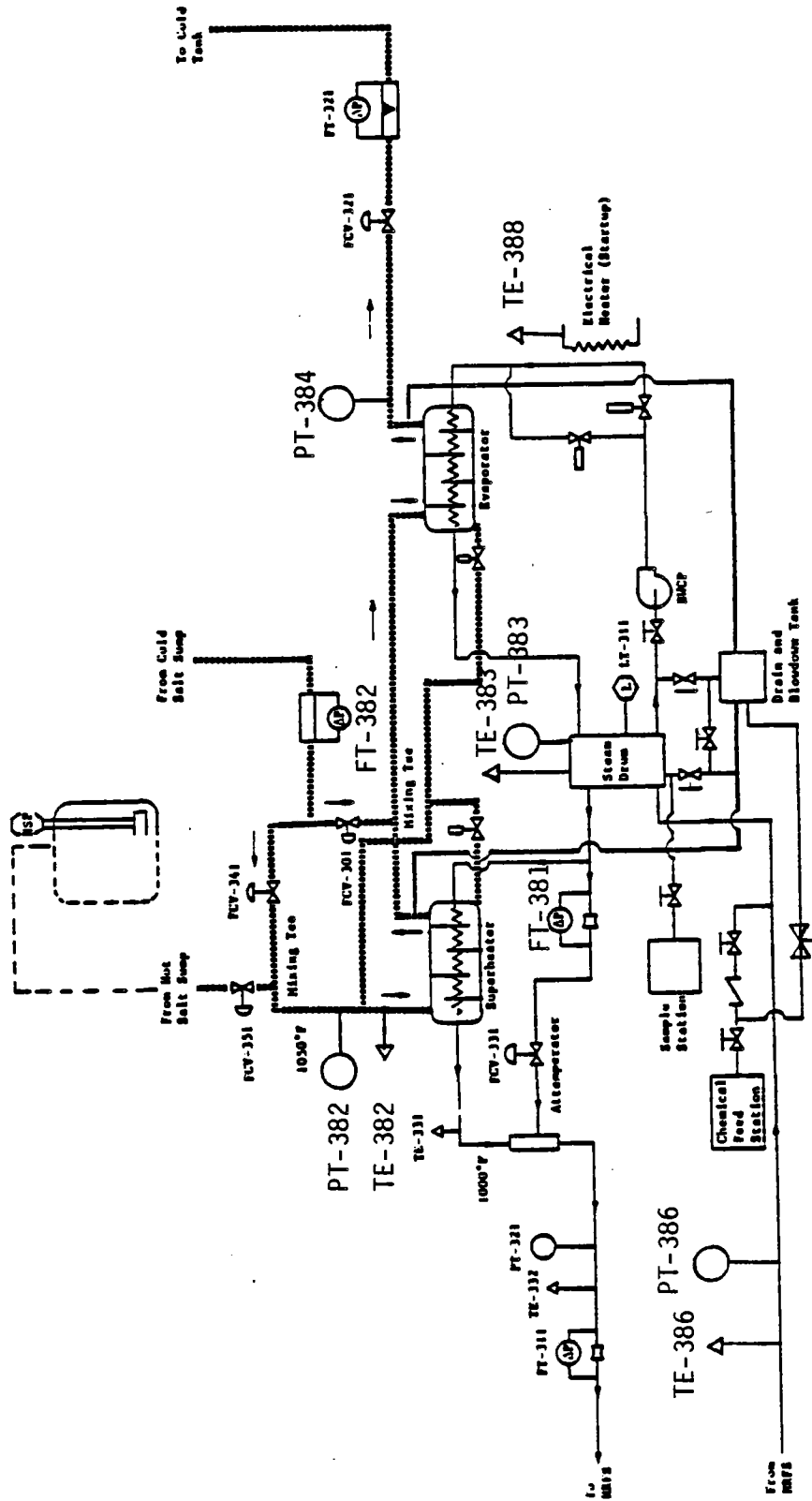

Figure 3.5 Steam Generation Subsystem (SGS)

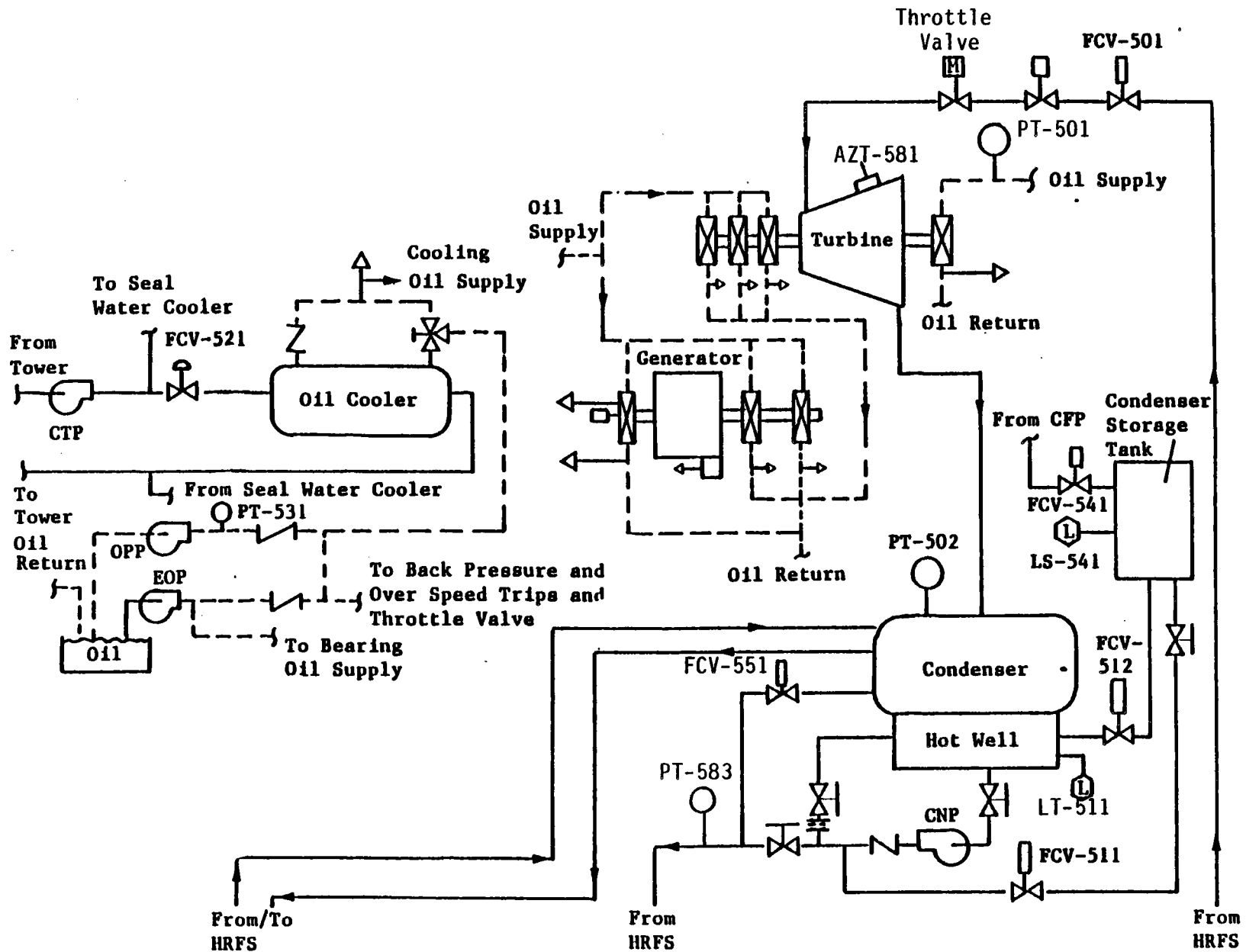

FIGURE 3.6 Electric Power Generation Subsystem (EPGS)

The turbine-generator set is a skid-mounted unit located at the north end of the receiver tower complex at the 80 ft. level (20 ft. below grade). This skid consists of a turbine, generator, and auxiliary equipment. The turbine is a seven-stage, single flow machine, operating at 17,400 rpm. Inlet steam conditions are 504°C (940°F) and 7.24 MPa (1050 psia). A single reduction gearbox reduces the turbine shaft speed to the generator speed of 1,200 rpm. The 750 kW<sub>e</sub> generator operates at 480 V, and is cooled by circulating water through air cooling coils located above the generator. The turbine-generator auxiliaries include a lubricating oil pump, lube oil cooler, air ejection vacuum pump and mechanical-hydraulic governor. Discussions with General Electric Company indicate that the load on the turbine can be ramped up or down at least as quickly as the allowable rate of change in load on the steam generator. This design value is 10 percent per minute from 30 to 100 percent of rated capacity.

A shell and tube condenser, supported by a separate frame, will be located directly below the turbine. Access to the condenser is on the floor 40 ft. below ground. Condensate from the hot well of the condenser will be transferred to the deaerator when the water level in the deaerator requires makeup. Otherwise, the condensate is pumped to a storage tank. Condensate from this tank is piped back to the condenser hot well when the hot well level requires water.

Warmup of the turbine generator is accomplished by steam from the steam generation subsystem.

### 3.6 HEAT REJECTION AND FEEDWATER SUBSYSTEM

The heat rejection and feedwater subsystem rejects waste heat to the atmosphere, pressurizes and heats the condensate to the final feedwater temperature. The subsystem (Figure 3.7) includes the cooling towers, circulating water pump, deaerator, spray water heat exchanger, spray water pump, feedwater pump, feedwater heater, demineralizers, chemical feeders, water analyzers, and condensate makeup pump. These major pieces of equipment, except the recently purchased feedwater pump, were used during the tests of the 10 MW<sub>e</sub> pilot plant water-steam receiver panel.

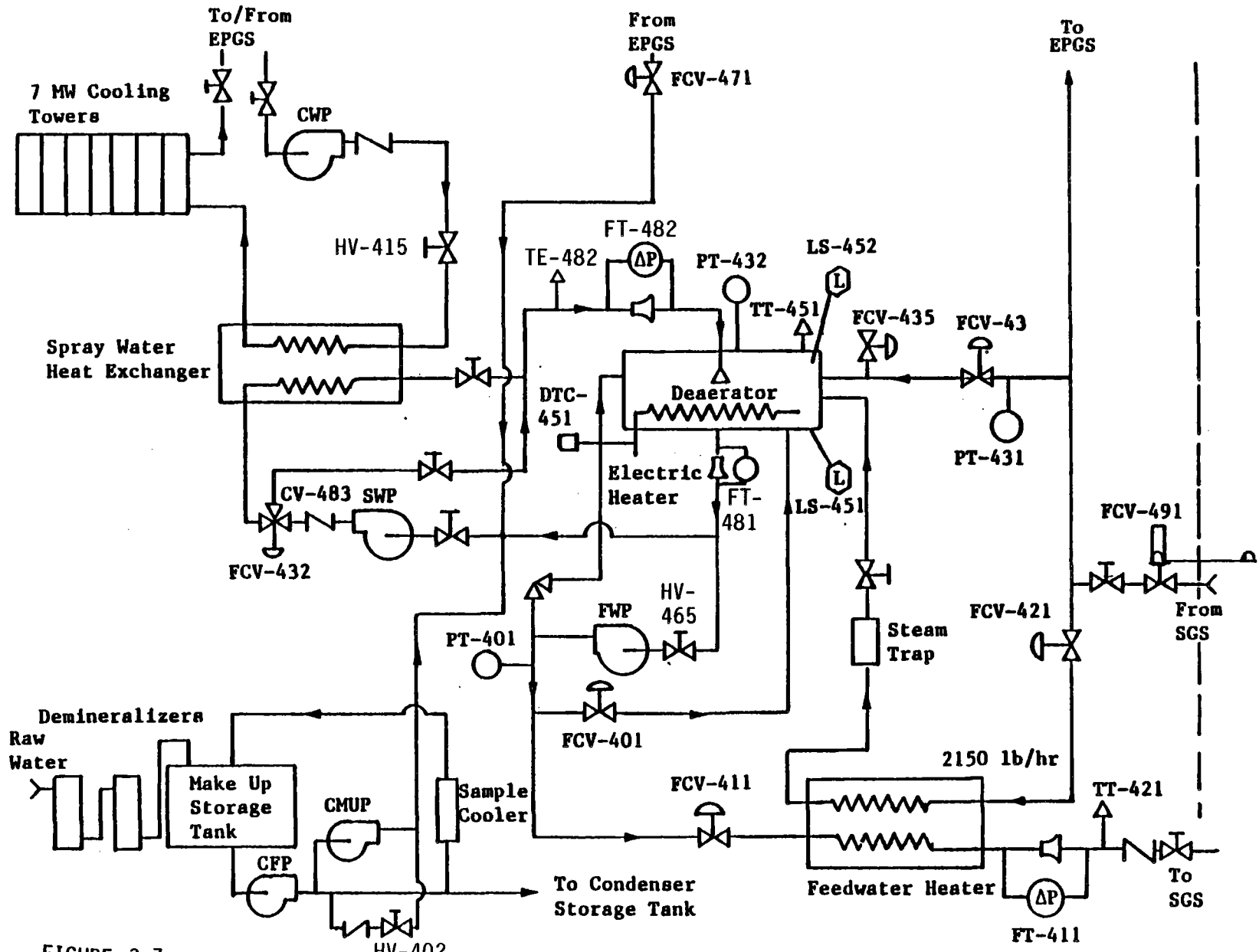

FIGURE 3.7  
Heat Rejection and Feedwater Subsystem (HRFS)

The cooling towers consist of six forced-draft, finned-tube water-to-air heat exchangers. They originally were designed as Freon condensers for refrigeration systems. As designed for the 10 MW<sub>e</sub> pilot plant panel test, the cooling towers had a duty of 7 MW<sub>t</sub> ( $24 \times 10^6$  Btu/hr) when cooling water from 93°C to 71°C (200°F to 160°F) using air at the design point temperature of 34°C (94°F). The turbine condenser cooling load in the MSEE, however, is approximately 2.7 MW<sub>t</sub> ( $8 \times 10^6$  Btu/hr), or about one-third the original duty. As a result, the cooling towers can provide cooling water temperatures closer to the design point air temperature.

The deaerator was originally designed as a direct contact condenser for the superheated steam from the 10 MW<sub>e</sub> pilot plant panel test. In this test, the deaerator will be used to reject steam generated by the SGS. It is a horizontal, cylindrical pressure vessel, designed to operate at 1.7 MPa and 204°C (250 psia and 400°F). It includes a steam header with mixing spargers near the bottom of the tank, water spray nozzles across the top, and two immersion electric heaters. It will be used in the MSEE as a direct contact feedwater heater and deaerator. Feedwater, stored in the deaerator, is heated by steam from a branch off the SGS mainline to the turbine. The feedwater is circulated by a spray water pump at 400 gpm from the bottom of the deaerator to the spray nozzles in the vapor space at the top of the deaerator where the water condenses the steam and is thereby heated. Condensate from the turbine condenser, blended into this spray water, is also heated to 204°C (400°F) and deaerated.

A new high speed, single stage centrifugal feedwater pump has been purchased to replace the existing positive displacement pump, which has been prone to leaks.

The feedwater heater is a vertical, cylindrical pressure vessel with an internal steam condensing coil. Feedwater from the deaerator is heated on the tube side as steam from a branch of the SGS mainline condenses on the shell side. The saturated liquid from the coil is cascaded down to the deaerator through a steam trap. Main steam is used for feedwater heating in the feedwater heater and the deaerator because there are no external extraction points on the turbine.

### 3.7 MASTER CONTROL

The master control subsystem (Figure 3.8) consists of an EMCON-D2 for system control and a equipment protection system. A Bailey network 90-system will be used to directly control the SGS. Commands and set points will be provided by the EMCON master control subsystem to the Network 90 for SGS operation and control. The equipment protection system is an independent hardwired relay shutdown system. These relay trip devices will shut down the receiver or the power generation ends of the MSEE when critical parameters reach preset limit values. These relay units are independent of the EMCON and network 90 control systems. Additionally, an Accurex Data Logger will be used to collect and display all the temperature measurements relating to the heat tracing and data instrumentation.

The EMCON-D2 is a distributed digital control system consisting of two operator consoles, a host computer with its peripheral hardware, a communication control module, and three process control modules distributed among the subsystems. Two EMCON-D2 operator consoles are located in the CRTF main control room. The host computer is an existing DEC PDP 11/34 unit located in the control room. This computer links the operator with the process control modules, and analyzes data from the control modules for presentation on the operator consoles. The peripheral equipment includes two disk drives, an alarm system, and a data analysis system.

A communication control module links the host computer with the three field-located, process control modules. Each process control module is a small digital computer capable of monitoring a number of instrumentation points, and responding with a number of process control signals. Communications between the control modules and host computer will be primarily limited to direct operator commands from the console and critical operating information from the subsystems for console display. This distributed control system reduces the number of instrumentation and control links between the subsystems and control room.

The communication control module consists of a digital computer control unit, a multiplexer, an analog-to-digital converter, and a digital-to-analog converter. Analog signals from the process instrumentation are converted to

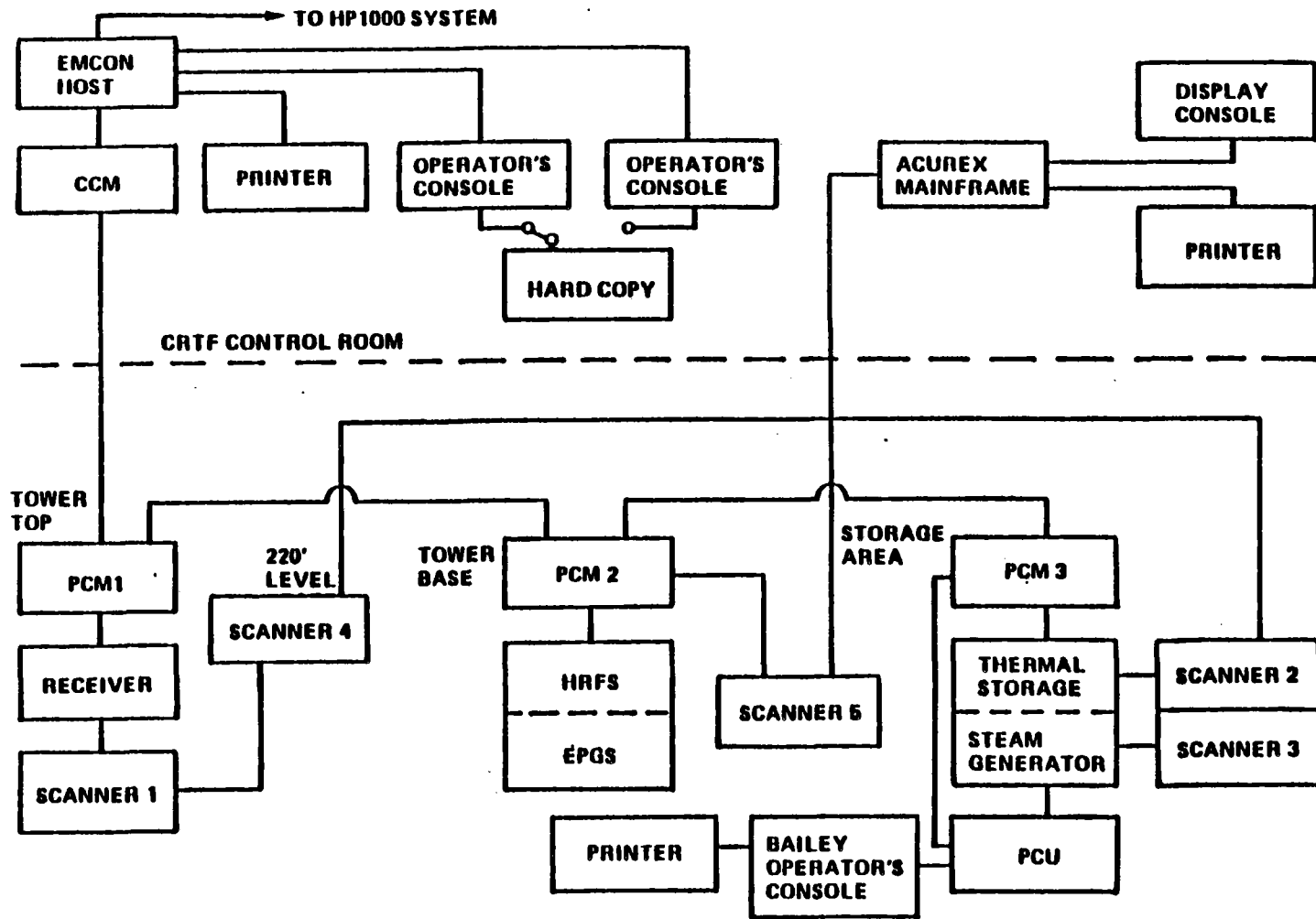

FIGURE 3.8 Master Control Subsystem



digital signals, selected in rotation by the multiplexer, and analyzed by the control unit. The module responds with an appropriate digital control signal which is passed through the multiplexer and sent to the appropriate controller. Each process control module is capable of monitoring 30 analog signals per second, monitoring 95 thermocouples, generating 20 analog control signals, and controlling over 100 on-off switches.

One process control module (PCM), located below the receiver in the tower elevator, will be dedicated to the control of the receiver. A second module, located at the base of the tower, will control the heat rejection and electric power generation subsystem. The third module, located in the control building adjacent to the salt storage tanks, will be used to control the thermal storage subsystem and to command the network 90 controlled steam generation subsystem.

The receiver subsystem PCM will modulate the salt flow rate to the receiver to maintain, as closely as possible, a constant outlet temperature of 566<sup>o</sup>C (1050<sup>o</sup>F). Individual thermocouples are located on the receiver to measure intermediate salt temperatures. From this information, the control module will estimate the flux on the receiver, and feed-forward a signal to the salt control valves at the receiver inlet. The control module will also control the receiver start-up and shutdown purge and drain valves.

Control of the thermal storage subsystem will involve the operation of the two salt downcomer flow control valves, cold salt pumps, salt storage tanks and piping heat tracing, and the propane-fired salt heater. The downcomer throttling valves will be controlled by the receiver control system to maintain a constant level in the receiver hot surge tank. Salt equipment heat trace temperatures will be monitored continuously by the Accurex Data Logger. The propane-fired salt heater will be operated intermittently, under manual control, during subsystem checkouts.

Automatic control of the heat rejection and electric power generation subsystem will involve the control of the steam and condensate flows to the deaerator, steam flow to the feedwater heater, and the operation of the cooling water, spray water condensate, and feedwater pumps. The EPGS condenser

temperature, level and pressure will be monitored by the master control subsystem. The deaerator temperature will be maintained by controlling the steam flow from the main steam header. The final feedwater temperature is maintained by controlling the main steam flow to the feedwater heater.

Automatic control of the steam generation subsystem will primarily involve the control of steam pressure, steam temperature, drum water level, and the evaporator salt inlet temperature through the network 90 control system. The water level in the drum will be controlled by modulating the control valve downstream of the feedwater pump. Control of the main steam pressure will be accomplished by modulating the salt flow control valve downstream of the evaporator. Steam temperature is controlled using an attemperator to mix steam from the steam drum with the output of the superheater. The evaporator salt inlet temperature will be controlled by monitoring the inlet salt temperature, and modulating the cold salt control valve at the mixing tee between the superheater and evaporator.

The Bailey Network 90 Control System consists of two process control units (PCU) and one operation interface unit (OIU).

The PCU architecture is based on two key modules, the Controller Module (COM) and the Logic Master. Together, these modules provide a mix of both modulating and sequential control functions including: base, cascade, or ratio PID control, high/low and rate limiters, engineering units conversion, general function generator, square root, summation multiplication, lead/lag, and transfer select, or, and, not, time delay, and several others. The controller module can service up to four analog and three digital inputs and two analog and four digital outputs. The COM also provides A/D and D/A conversion, alarm limit checking (absolute and deviation) and notification, point quality checking and interlocking.

The Operator Interface Unit (OIU) provides the high level operator interface for the Network 90 system. The OIU consists of a color CRT-based table-top console, with functional keyboard, mass storage device, and console driver electronics.

In operation, the unit performs the system information display and control requirements. The OIU console includes a CRT keyboard and pushbutton hardware

for process overview, alarm indicating, loop control, trending, tuning and configuration functions.

The OIU uses microprocessor, memory and I/O modules to support system functions. It furnishes monitoring, supervisory, recording and display capability at centralized or distributed locations, along with engineering functions.

### 3.8 DATA ACQUISITION SUBSYSTEM (DAS)

The DAS utilizes both the EMCON-D2 and an HP-1000. EMCON collects the data and HP-1000 stores and displays data. Data collected by the EMCON system is transmitted to the HP-1000 system on a terminal-to-terminal data link. The tag list for the data to be collected is in a file of 120 tags, which are divided into 4 groups of 30 tags. One group of 30 is transmitted every 15 seconds, giving a total update rate of once a minute. The data are then time tagged with day of the year, hour, minute, second, millisecond. Then the data are stored in a data file and/or displayed on one of six CRTs in a graphical form. Also, the data are transmitted in integer format, not floating point, but they are in engineering units. The data files are divided into eight-hour blocks, so if a test runs longer than eight hours, another eight-hour block is assigned to that test's file. Normally an 8-hour data block is stored in 19 tracks out of a maximum usable 1000 tracks.

The live data can be displayed on the 6 CRTs with 3 tags per screen, a time scale of 3 hours 20 minutes, and a Y-scale displayed of the first tag's display range. The other two tags are displayed using their respective ranges, but the scales are not shown on the plot. When the plot is full the plot scrolls left dropping the oldest 1/4 of the time scale data. This leaves 1/4 of the plot blank for new data. These plots can have hard copies made, but not automatically. The print is done by manual switch selection of each screen and a copy page switch.

Recovery of stored data can be done whenever live data files are not being made. These plots have a slightly different format, three being a maximum of five tags per plot, and the Y scale shown is that of the last tags range. These plots are not displayed on a CRT, but directly generated on the printer/plotter.

## Section 4

### PHASE II ROLES AND RESPONSIBILITIES

#### 4.1 PHASE II CONTRACT MANAGER (The Electric Power Research Institute)

The Phase II Contract Manager will be responsible for the technical and contract control of the McDonnell Douglas Phase II activities. In addition, EPRI will solicit and coordinate, together with the Public Service Company of New Mexico, the participation of utility operating teams. The final report for the MSEE project will be published and distributed by EPRI.

#### 4.2 MSEE PROJECT MANAGER (Sandia National Laboratories, Livermore)

The Project Manager will be responsible for the day-to-day coordination and management of all aspects of the project. The Project Manager will have the authority to plan and execute activities with the concurrence of the Executive Committee.

In addition, the Project Manager will perform the following test functions:

- a) Review and approve the Phase II Test Plan
- b) Review and approve the integrated test procedures (ITP)
- c) Establish and maintain the program test schedule
- d) Enter into contractual arrangements for any required supporting equipment or services

#### 4.3 SITE MANAGER (The Central Receiver Test Facility)

The CRTF Site Manager will be responsible for the complete maintenance of MSEE equipment and the overall conduct of all tests. This will include the following:

- a) Be responsible for MCS operation and maintenance
- b) Maintain up-to-date file of all turnover records
- c) Conduct configuration management change committee reviews
- d) Review and approve all plans and procedures

- e) Provide personnel for operations, maintenance and data acquisition and handling
- f) Approve the test approach presented at pretest meetings
- g) Final authority on test/maintenance activities and their scheduling
- h) Maintain safety responsibility which includes the authority to shut down testing when hazardous conditions or unexpected test results occur
- i) Maintain test procedures documentation

#### 4.4 MSEE PHASE I SYSTEMS INTEGRATOR (Martin Marietta)

The Phase I Systems Integrator will be responsible for the turnover of the Phase I documentation test program results and of the MSEE. Specifically, the Systems Integrator shall be responsible for the following:

- a) Provide red-lined test procedures from Phase I (as of April 6, completed)
- b) Provide all Phase I documentation
- c) Review significant changes to test procedures
- d) Provide full-time controls/instrumentation engineer on-site through June 1984.
- e) Review configuration management changes
- f) Provide quick look analysis of Phase I test results
- g) Provide Final Report on Phase I

#### 4.5 TECHNICAL COMMITTEE

The Technical Committee will help guide the technical aspects of the Phase II tests including the following:

- a) Establish Phase II objectives/priorities (accomplished)
- b) Review and comment on test plan
- c) Periodic review of Phase II test results

#### 4.6 EQUIPMENT SUPPLIERS

- a) Provide all documentation on equipment and Phase I checkout and testing
- b) Identify any special data desired from Phase II tests
- c) Consult on post-Phase II plan

#### 4.7 HOST UTILITY (Public Service Company of New Mexico)

The host utility will coordinate, together with EPRI, the participation of operating teams from other utilities. Additionally, PNM will provide the first team of utility operators in Phase II.

#### 4.8 UTILITY SPONSORS (APS, PG&E, and SCE)

All utility sponsors have agreed to provide either a full or partial operating team for Phase II. In addition, several other utilities can provide a single operator or engineer to participate in the Phase II test program.

Utility sponsors also participate on the Technical Committee (4.5) so those roles are also included.

#### 4.9 MCDONNELL DOUGLAS ASTRONAUTICS COMPANY (MDAC)

MDAC will be responsible to define the testing required to meet the Phase II goals and objectives and specifically perform the following:

- a) Provide Phase II test plan and schedule
- b) Redline test procedures and participate in reviews
- c) Conduct daily status meetings
  - o Describe daily test activity, including test objectives, description and data required
  - o If no testing, prioritize maintenance and repair
  - o Update schedules
- d) Maintain daily test log
- e) Participate on configuration management review committee
- f) Report weekly status to SNLL/EPRI
- g) Provide system evaluation
- h) Provide periodic progress reviews
- i) Prepare final report

Section 5  
TEST PROGRAM DESCRIPTION

5.1 GENERAL

Phase II tests, operating modes and transitions and pertinent Phase I Procedures are identified here.

5.1.1 Phase II Tests

Phase II tests are grouped into four categories. Part A tests will be used to generate the test data to be used to evaluate performance and functional capability of the MSEE. Part B contains training tests which will be used to train utility operator teams. Part C contains those tests that will be performed to evaluate the routine operation of MSEE as a utility power plant. They will be used to produce extended performance information using the optimum operating strategy developed in Part A tests. These tests will be conducted by the utility operator teams. Part D tests will be conducted throughout Phase II by Olin to obtain data on salt properties, stability and corrosion. These Phase II tests are listed below:

Part A - MSEE Characterization

- II-1 Receiver Loop Performance
- II-2 Power Production Subsystems Performance
- II-3 Transient Response of Receiver Loop
- II-4 Overnight Thermal Conditioning of the Receiver
- II-5 Overnight Hold Conditions for the Steam Generator
- II-6 Development of Optimum Operating Strategy

Part B - Training Tests

- II-7 Receiver Loop Cold Flow
- II-8 Receiver Loop Operation
- II-9 Receiver Operation with Simulated (Slow) Cloud
- II-10 Thermal Storage Charging with Propane Heater
- II-11 Steam Generator and HRFS Operation
- II-12 Operation of Full Electric Loop (TSS through EPGs)

### Part C - Operation As A Utility Power Plant

- II-13 System Operation from Receiver
- II-14 System Operation with Fossil Fuel

### Part D - Salt Characteristics

- II-15 Salt Properties and Stability
- II-16 Salt Corrosion

#### 5.1.2 Modes of Operation and Transitions

The operating modes and transitions for each subsystem are described below:

##### Receiver Operating Modes

- RS1 Receiver cold and drained
- RS2 Receiver drained with trace heat on
- RS3 Receiver drained with trace heat on and warm-up heliostats
- RS4 Receiver cold flow with trace heat on and warm-up heliostats
- RS5 Receiver cold flow with trace heat on, no warm-up heliostats and receiver door closed
- RS6 Receiver operation, manual with flow control
- RS7 Receiver operation, temperature control

##### Receiver Transitions

- o Start-up
  - RS1 to RS2 - Turn on trace heaters
  - RS2 to RS3 - Drained and warm to warm-up heliostats
  - RS3 to RS4 - Warm-up heliostats to cold flow through receiver
  - RS4 to RS5 - Cold flow through receiver with receiver door closed
  - to RS6 - To salt flow through receiver with flow control
  - to RS7 - To salt flow through receiver with temperature control
- RS6 to RS7 - Salt flow with flow control to temperature control



- o Shutdown
  - RS7 to RS6 - Salt flow with temperature control to flow control
  - to RS5 - Salt flow with temperature control to cold flow with door closed
  - to RS2 - Salt flow with temperature control to drained with trace heat on
  - RS6 to RS5 - Salt flow with flow control to cold flow with door closed
  - to RS2 - Salt flow with flow control to drained with trace heat on
  - RS5 to RS2 - Cold flow with door closed to drained with trace heat on
  - RS4 to RS2 - Cold flow with warm-up heliostats to drained with trace heat on
  - RS3 to RS2 - Drained with warm-up heliostats to drained with trace heat
  - RS2 to RS1 - Turn off trace heaters

#### Thermal Storage Operating Modes

- TSS1 Hot tank drained and cold
- TSS2 Hot and cold salt tanks warm and ready for operation
- TSS3 Charging with propane heater

#### Thermal Storage Transitions

- o Start-up
  - TSS1 to TSS2 - Pre-test check lists to pre-conditioning hot salt tank
  - TSS2 to TSS3 - Pre-test check lists to charging hot salt tank
- o Shutdown
  - TSS3 to TSS2 - Charging hot salt tank to shutdown, salt in both tanks
  - TSS2 to TSS1 - Drain hot tank



### 5.1.3 Application of Phase I Procedures

The procedures being developed in Phase I which will be utilized in the Phase II test program are described below:

<u>Subsystem Transitions</u>	<u>Subsystem Procedures</u>	<u>System Procedures</u>
<u>Receiver Subsystem (RS)</u>		
Start-up		
RS1 - RS2	Turn on trace heaters	Turn on trace heaters
RS2 - RS3	GROP #1, 1A, & 2 GSGP #1/1A	GSOP #1, 6, 7, 2 & 3
RS3 - RS4	GROP #2	GSOP #7
RS4 - RS5	GROP #2	GSOP #7
RS4 - RS6	GROP #2	GSOP #7
RS4 - RS7	GROP #2	GSOP #7
RS5 - RS6	GROP #2	GSOP #7
RS5 - RS7	GROP #2	GSOP #7
RS6 - RS7	GROP #2	GSOP #7
Shutdown		
RS7 - RS6	GROP #3	GSOP #8
RS7 - RS5	GROP #3	GSOP #8
RS7 - RS2	GROP #3 & 5 GSGP #6	GSOP #8, 10 & 12
RS6 - RS5	GROP #3	GSOP #8
RS6 - RS2	GROP #3 & 5 GSGP #6	GSOP #8, 10 & 12
RS5 - RS2	GROP #3 & 5 GSGP #6	GSOP #8, 10 & 12
RS4 - RS2	GROP #3 & 5 GSGP #6	GSOP #8, 10 & 12
RS3 - RS2	GROP #3 & 5 GSGP #6	GSOP #8, 10 & 12
RS2 - RS1	Turn off trace heaters	Turn off trace heaters

<u>Subsystem Transitions</u>	<u>Subsystem Procedures</u>	<u>System Procedures</u>
<u>Thermal Storage Subsystem (TSS)</u>		
Start-up		
TSS1 - TSS2	GROP #1A GSGP #1/1A & 4	GROP #6, 2 & 3
TSS2 - TSS3	GSGP #9 & 4	N/A
Shutdown		
TSS3 - TSS2	Allow hot tank to cool to 700 <sup>o</sup> F	Allow hot tank to cool
TSS2 - TSS1	GSGP #9	N/A
<u>Steam Generation Subsystem (SGS)</u>		
Start-up		
SGS1 - SGS2	GSGP #1, 2 or 2A, APPENDIX C of GROP #1A	GSOP #2, 3, 7, 4 & 6
SGS2 - SGS3	GSGP #1A, 2 or 2A APPENDIX C of GROP #1A	GSOP #6, 7, 4
SGS3 - SGS4	GSGP #2 or 2A	GSOP #7
SGS4 - SGS5	GSGP #2 or 2A	GSOP #7
Shutdown		
SGS5 - SGS4	GSGP #3 or 3A	GSOP #8
SGS4 - SGS3	GSGP #3 or 3A	GSOP #8
SGS3 - SGS2	GSGP #3 or 3A, APPENDIX C of GROP #1A	GSOP #8, 13 & 6
SGS2 - SGS1	SGS Manual, Section 3.9	SGS Manual, Section 3.9
<u>Electric Power Generation Subsystem (EPGS)</u>		
Startup		
EPGS1 - EPGS2	GROP 1A, GEPGP #1, 1A & 2, APPENDICES A, B, and C	GSOP #6, 5, 7, 2, 3, & 4
EPGS2 - EPGS3	GEPGP #2	GSOP #7
EPGS3 - EPGS4	GEPGP #2	GSOP #7

Subsystem  
Transition

Subsystem  
Procedures

System  
Procedures

Shutdown

EPGS4 - EPGS3

EPGS3 - EPGS2

EPGS2 - EPGS1

GEPGP #3

GEPGP #3

GEPGP #3 & 5,

APPENDICES A, B, and C

GSOP #8

GSOP #8

GSOP #8, 14, 11, 12 & 13

## 5.2 TEST II-1 - RECEIVER LOOP PERFORMANCE

### Description:

- o Calibrate receiver flow meter and receiver inlet and outlet thermocouples
- o Run receiver loop in cold flow conditions
- o Run receiver at various power levels with TSS, SGS, & HRFS operating

### Objectives:

- o Determine receiver thermal loss rates at two temperatures
- o Determine steady state performance for full and part load operation
- o Verify receiver subsystem controllability under full and part load conditions

### Pretest Conditions (Calibration and Thermal Loss Rate Tests):

- o RS2; receiver drained with trace heat on
- o TSS1; hot tank drained and cold or  
TSS2; hot and cold salt tanks warm and ready for operation
- o At least 70% of salt inventory in cold tank at one of the two temperatures listed under test matrix (below)
- o Insolation for receiver warm-up

### Calibration

- o Receiver flow (FT-101) - Calibrate before testing; check calibration following tests
- o Receiver inlet and outlet temperature (TE-101 and TE-102) - Use data from receiver thermal loss tests, steps 4 through 8.

### Test Matrix (Receiver Thermal Loss Tests)

<u>Receiver Flow Rates (Klb/hr)</u>	<u>Receiver Salt Inlet Temperature (°F)</u>
20	
40	Approx. 590
60	
80	Approx. 700
100	

Test Sequence - (Receiver thermal loss tests; conducted for both receiver inlet temperatures listed in the test matrix)

These tests may be conducted on different days except that each case covered by steps 4 through 8 and steps 9 through 13 must be completed under constant ambient conditions.

1. RS2 to RS3; receiver drained, add warmup heliostats
2. RS3 to RS4; receiver cold flow
3. RS4 to RS5; remove warmup heliostats, close receiver door
4. Establish receiver flow at 20 Klb/hr
5. Wait until flow and temperatures stabilize; record data
6. Repeat steps 4 and 5 for flow rates of 40K, 60K, 80K and 100K lb/hr substituted for 20 k lb/hr
7. Open Receiver door
8. Repeat steps 4, 5, and 6
9. Select one receiver flow condition from the test matrix.
10. Wait until flow and temperatures stabilize; record data
11. Open receiver door; repeat step 10
12. Add heliostats until receiver inlet (TE-101) and outlet (TE-102) temperatures become equal
13. Repeat step 10
14. Repeat steps 9 through 13 for the remaining receiver flows in the test matrix

Pretest Conditions (Receiver Performance Tests):

- o RS2; receiver drained with trace heat on
- o TSS2; hot and cold salt tanks warm and ready for operation
- o Temperature of salt in cold tank: approximately 590<sup>o</sup>F
- o SGS2; SGS warm and salt drained (diurnal shutdown)
- o Clear day

Test Matrix (Receiver Performance Tests)

<u>Receiver Power Level (% of Full Rating)</u>	<u>Receiver Outlet Temperature (°F)</u>
25	1050
50	1050
75	1050
100	1050
75	935
50	820

Test Sequence (Receiver Performance Tests):

1. SGS2 to SGS4; warm and salt drained to SGS operating in boiler following control mode at 30% of rated output
2. RS2 to RS3; pre-test checklists to warm-up heliostats
3. RS3 to RS4; warm-up heliostats to cold flow through receiver
4. Set receiver flow for one case in test matrix
5. RS4 to RS7; set receiver outlet salt temperature setpoint to value of test case from test matrix
6. Adjust SGS salt flow as required to maintain levels in hot and cold salt tanks and outlet salt temperature of 590<sup>0</sup>F
7. Wait until receiver flow and temperatures stabilize; record data
8. Repeat steps 4 through 7 for remaining cases in test matrix
9. RS7 to RS2; full flow temperature control to shutdown and drained
10. SGS4 to SGS2; SGS operating in boiler following mode to warm and salt drained

Success Criteria:

- o Successful operation of receiver throughout all tests
- o Instruments stay within calibration throughout test
- o Specified data collected and recorded

Primary Data Requirements:

- o Ambient air temperature, barometric pressure, relative humidity, wind speed and direction
- o Number of heliostats on target

RECORD DATA AT ONE-MINUTE INTERVALS FOR 10 MIN. AFTER STEADY STATE CONDITIONS ARE OBTAINED.

- o Pyroheliometer readings
- o Receiver salt inlet temperature (TE-101)
- o Receiver salt outlet temperature (TE-102)
- o Receiver salt flow rate (FT-101)
- o Receiver panel back tube temperatures (TE-103 through TE-120 and TE-131 through TE-148)
- o Cold surge tank pressure (PT-182)
- o Cold surge tank level (LT-151)
- o Receiver salt inlet pressure (PT-181)
- o Receiver subsystem heat trace circuit current readings



- o Cold salt sump pump and cold salt boost pump current readings
- o Hot salt surge tank level (LT-161)
- o Cold salt storage tank heat trace current readings
- o Cold salt storage tank temperatures  
(TE-281, TE-282 and TE-283)
- o Cold salt storage tank level (LT-281)
- o Hot salt storage tank temperatures  
(TE-291, TE-292 and TE-293)
- o Hot salt storage tank level (LT-291)
- o Cold salt pump and cold salt boost pump outlet pressures  
(PT-281 and PT-280)

### 5.3 TEST II-2 - POWER PRODUCTION SUBSYSTEMS PERFORMANCE

#### Description:

- o Run steam generator and turbine/generator at full and partial loads

#### Objectives:

- o Determine steady state performance for full and part load operation
- o Determine system responses and controllability at partial flow conditions

#### Calibration:

- o Calibrate FT-382 and FT-321 together
- o Check readings of FT-311 against FT-411 with constant drum level and pressures; remove and bench test both units if readings are different (more than 3%)

#### Pretest Conditions:

- o RS2; receiver drained with trace heat on
- o TSS2; hot and cold salt tanks warm and ready for operation (at least 50% salt inventory in hot tank at a temperature of 900<sup>0</sup>F or above)
- o SGS2; SGS warm and salt drained (diurnal shutdown)
- o EPGS2; turbine standby - pumps on

#### Test Sequence:

1. SGS2 to SGS4; warm and salt drained to SGS operating in boiler-following control mode at 30% of rated output
2. EPGS2 to EPGS3; turbine standby to operating offline
3. EPGS3 to EPGS4; turbine generator operating offline to operating synchronized
4. Increase generator power to 225 kW<sub>e</sub> at a rate of 75 kW<sub>e</sub> per minute or less and stabilize
5. SGS4 to SGS5; SGS operating in boiler-following control mode to operating in turbine following mode
6. RS2 to RS7; set outlet temperature setpoint (TE-102) to 1050<sup>0</sup>F
7. Adjust heliostat field to maintain levels in hot and cold salt tanks  
ALTERNATE TO STEPS 6 AND 7: OPERATE PROPANE HEATER TO MAINTAIN HOT SALT INVENTORY

8. Wait until hot salt supplied to SGS is at least 1000<sup>o</sup>F
9. Increase power to 250 kW<sub>e</sub> at a rate of 75 kW<sub>e</sub> per minute or less and stabilize; record data
10. Increase power to 500 kW<sub>e</sub> at a rate of 75 kW<sub>e</sub> per minute or less, repeat step 7 and stabilize; record data
11. Increase power to 750 kW<sub>e</sub> at a rate of 75 kW<sub>e</sub> per minute or less, repeat step 7 and stabilize; record data
12. Decrease power to 500 kW<sub>e</sub> at a rate of 75 kW<sub>e</sub> per minute or less, repeat step 7 and stabilize; record data
13. Decrease power to 250 kW<sub>e</sub> at a rate of 75 kW<sub>e</sub> per minute or less, repeat step 7 and stabilize; record data
14. SGS5 to SGS4; SGS operating in turbine following mode to operating in boiler-following mode
15. RS7 to RS2; shut down and drain receiver
16. EPGS4 to EPGS2; decrease power from generator to zero at a rate of 10% per minute or less
17. EPGS2 to EPGS1; turbine standby to shutdown
18. SGS4 to SGS2; SGS operating in boiler-following control mode to warm and salt drained

Success Criteria:

- o Successful operation of system at full and part load
- o Controls behavior acceptable
- o Specified data collected and recorded

Primary Data Requirements:

- o Ambient air temperature, barometric pressure, relative humidity, wind speed and direction

RECORD DATA AT ONE MIN. INTERVALS FOR 10 MIN. AFTER STEADY STATE CONDITIONS ARE REACHED;

- o Hot salt storage tank temperatures  
(TE-291, TE-292, and TE-293)
- o Cold salt storage tank temperatures  
(TE-281, TE-282, and TE-283)
- o Superheater salt inlet temperature (TE-382)
- o Superheater salt inlet pressure (PT-382)

- o Evaporator salt inlet temperature (TE-301)
- o Evaporator salt outlet temperature (TE-384)
- o Evaporator salt outlet pressure (PT-384)
- o SGS cold salt flow rate (FT-382)
- o SGS total salt flow rate (FT-321)
- o Feedwater inlet temperature (TE-386)
- o Feedwater inlet pressure (PT-386)
- o Feedwater inlet flow rate (FT-411)
- o Steam drum water level (LT-311)
- o Steam drum pressure (PT-383)
- o Steam drum temperature (TE-383)
- o Superheater outlet steam temperature (TE-331)
- o Attemperator saturated steam flow rate (FT-381)
- o SGS outlet steam temperature (TE-332)
- o SGS outlet steam pressure (PT-321)
- o SGS outlet steam flow rate (FT-311)
- o Turbine inlet steam pressure (PT-581)
- o Turbine inlet steam temperature (TE-583)
- o Deaerator steam inlet temperature (TE-483)
- o Deaerator steam inlet pressure (PT-431)
- o Condensor steam inlet temperature (TI-581) (Record manually)
- o Condensor steam pressure (PT-502)
- o Hot well level (LT-511)
- o Deaerator level (LT-471)
- o Deaerator pressure (PT-432)
- o Deaerator steam temperature (TE-481)
- o Deaerator water temperature (TE-451)
- o Deaerator outlet flow (FT-481)
- o Feedwater heater outlet temperature (TE-421)
- o Feedwater heater outlet pressure (PT-483)
- o Generator speed (ST-582)
- o Generator watt meter reading (JT-581)
- o Generator voltage (ET-581)
- o Generator current (IT-581)
- o Generator VARS (VT-581)
- o Generator power factor (PFT-581)
- o All motor currents (Record manually)
- o SGS heat trace currents

## 5.4 TEST II-3 - TRANSIENT RESPONSE OF RECEIVER LOOP

### Description:

- o Operate receiver loop through progressively faster ramp increases in power

### Objectives:

- o Develop map of system response to flux transients
- o Verify controls response to fast transients and adjust controllers if required
- o Develop limits of sun tracking through cloud passage
- o Develop minimum receiver start-up time

### Pretest Conditions:

- o RS2; receiver drained with trace heat on
- o TSS2; hot and cold salt tanks warm and ready for operation (at least 70% salt inventory in cold tank)
- o SGS2; SGS warm and salt drained (diurnal shutdown)
- o EPGS; not applicable
- o Clear day

Test Sequence (Repeated from different initial conditions of salt flow rate, power and receiver outlet temperature and with different ramp rates in power and final power level; these test cases are given in Table 5-1)

1. RS2 to RS3; pre-test checklists to warm-up heliostats
2. RS3 to RS4; warm-up heliostats to cold flow through receiver
3. Establish salt flow through the receiver of 60,000 lb/hr
4. Bring all heliostats to be used for test case to near standby
5. RS4 to RS6; bring 25 percent of heliostat field onto the receiver
6. RS6 to RS7; set receiver outlet temperature control setpoint to value given in column A of Table 5-1. (Start with case 1)
7. Allow salt flow to stabilize and control at this outlet temperature
8. Add number of heliostats given in column B at the interval from column C for the particular test case

9. Monitor receiver temperatures
10. Monitor receiver control response
11. Allow receiver temperatures and salt flow rate to stabilize
12. Repeat previous four steps until the total number of increments given in column D have been added
13. Operate SGS and HRFS as necessary to reject heat and maintain cold salt inventory in cold storage tank

CRITERIA FOR SUCCESSFUL COMPLETION OF TEST AND PROGRESSION TO SUCCEEDING TEST CASE

- A. Stable control of receiver outlet temperature as defined in MCS specification
  - B. Outlet temperature never exceeds 1070<sup>0</sup>F
  - C. Back tube temperatures stay within limits
  - D. Surge tank levels remain within limits.
14. Reduce number of heliostats on target to 25 percent of field
  15. Repeat previous steps for next test case if criteria above have been successfully met.
  16. RS7 to RS2; shut down and drain receiver
  17. SGS (if operated) to SGS2

Success Criteria

- o Successful determination of maximum transient capability of receiver
- o Data system operational throughout tests and specified data recorded
- o Controllability of receiver during flux transients

Primary Data Requirements;

- o Ambient air temperature, barometric pressure, relative humidity, wind speed and direction

DATA ARE TO BE TAKEN CONTINUOUSLY THROUGH TESTING

- o Number of heliostats on target
- o Hot salt storage tank temperatures (TE-291, TE-292, and TE-293)
- o Hot salt storage tank level (LT-291)

- o Riser heat trace current readings
- o Downcomer heat trace current readings
- o Receiver heat trace current readings
- o Cold salt sump pump, and cold salt boost pump current readings

THE FOLLOWING DATA ARE TO BE TAKEN AT MAXIMUM UPDATE RATE

- o Pyroheliometer readings
- o Receiver salt inlet temperature (TE-101)
- o Receiver salt outlet temperature (TE-102)
- o Receiver salt flow rate (FT-101)
- o Receiver back tube temperatures  
(TE-103 through TE-120 and TE-131 through TE-148)
- o Cold salt surge tank pressure (PT-182)
- o Cold salt surge tank level (LT-151)
- o Receiver salt inlet pressure (PT-181)
- o Hot surge tank level (LT-161)
- o Hot surge tank temperature (TE-183)
- o Downcomer exit salt temperature (TE-161)
- o Cold salt storage tank temperatures  
(TE-281, TE-282, TE-283)
- o Cold salt storage tank level (LT-281)
- o Cold salt storage tank heat trace current readings

Table 5-1

## Description of Test Cases

	<u>A</u>	<u>B</u>	<u>C</u>	<u>D</u>	<u>E</u>
Test Case No.	Receiver Outlet Set Point (°F)	Heliostat Increment Size (% of Field)	Interval between Additions (sec)	No. of Incre- ments	Final Heliostats on Target (% of Field)
1	820	12.5	120	2	50
2	820	12.5	60	2	50
3	820	12.5	30	2	50
4	820	12.5	10	2	50
5	820	25	NA	1	50
6	940	12.5	120	4	75
7	940	12.5	60	4	75
8	940	12.5	30	4	75
9	940	12.5	10	4	75
10	940	25	30	2	75
11	940	25	10	2	75
12	940	50	NA	1	75
13	1050	12.5	120	6	100
14	1050	12.5	60	6	100
15	1050	12.5	30	6	100
16	1050	12.5	10	6	100
17	1050	25	30	3	100
18	1050	25	10	3	100
19	1050	50	30	2	100
20	1050	50	10	2	100
21	1050	75	NA	1	100



## 5.5 TEST II-4 - OVERNIGHT THERMAL CONDITIONING OF FILLED RECEIVER

### Description:

- o Maintain filled receiver warm with the door closed by pulsing salt flow through the receiver from the cold surge tank and replenishing cold surge tank level, when required, with the pump.

### Objectives:

- o Determine most efficient operations to maintain the receiver in the filled, warm condition overnight

### Pretest Conditions:

- o RS2; receiver drained with trace heat on
- o TSS2; at least 40 percent of salt inventory in cold tank at temperature of 590<sup>0</sup>F or above
- o Sufficient insolation for warm-up heliostats

### Test Sequence:

1. RS2 to RS3; receiver drained to warm up heliostats
2. RS3 to RS4; receiver cold flow
3. RS4 to RS5; receiver cold flow with door closed and heliostats off
4. Stop receiver salt flow (close FCV-101 and FCV-102); start timer and data recording
5. Verify cold tank level (LT-151) is at least 85 inches
6. Isolate cold surge tank (close FCV-151)
7. When minimum receiver temperature reaches 530<sup>0</sup>F, pulse flow through receiver from cold surge tank using FCV-101 or FCV-102 (vary size of pulse for different test cases)
8. Repeat step 7 until cold surge tank level (LT-151) reaches 20 inches
9. Fill cold surge tank with cold salt as required to replenish level to 85 inches by opening FCV-151
10. Repeat steps 8 through 10 for duration of test
11. RS5 to RS2; shut down and drain receiver

Success Criteria:

- o Salt-filled receiver maintained warm in a simulated overnight hold condition
- o Specified data collected and recorded

Primary Data Requirements:

- o Ambient air temperature, barometric pressure, relative humidity, wind speed and direction

DATA TO BE TAKEN THROUGHOUT TEST AT 1 MINUTE INTERVALS

- o Receiver salt inlet temperature (TE-101)
- o Receiver salt outlet temperature (TE-102)
- o Receiver back tube temperatures  
(TE-103 through TE-120 and TE-131 through TE-148)
- o Receiver salt inlet pressure (PT-181)
- o Hot surge tank level (LT-161)
- o Hot surge tank temperature (TE-183)
- o Cold surge tank level (LT-151)
- o Cold surge tank pressure (PT-182)
- o Cold surge tank temperature (TE-182)
- o Receiver downcomer outlet temperature (TE-161)
- o Receiver and cold salt boost pump discharge pressure (PT-180)
- o Cold salt storage tank temperatures  
(TE-281, TE-282 and TE-283)

DATA TO BE TAKEN AT MAXIMUM UPDATE RATE OF ACUREX

- o Cold salt storage tank heat trace currents
- o Receiver heat trace currents
- o Riser and downcomer heat trace currents
- o Receiver hot and cold surge tank heat trace currents
- o Cold sump and cold salt boost pump heat trace currents
- o Receiver header temperatures

DATA TO BE RECORDED MANUALLY

- o Time, duration and current readings for salt pump operation

## 5.6 TEST II-5 - OVERNIGHT HOLD CONDITIONS FOR SGS

### Description:

- o Hold SGS warm and filled with salt in diurnal shutdown condition

### Objectives:

- o Compare diurnal hold using salt for thermal input with the baseline electrical heater

### Pretest Conditions:

- o Receiver - NA
- o TSS2; at least 40 percent of salt inventory in cold tank at temperature of 590<sup>0</sup>F or above
- o EPGS - NA
- o SGS2; diurnal shutdown

### Test Sequence:

1. SGS2 to SGS3; diurnal shutdown to cold salt flow
2. Establish drum level (LT-311) of 6 inches at drum pressure (PT-383) of 1200 psi
3. Isolate steam generator (shut FCV-341, FCV-411 and FCV-491), verify that FCV-301 is closed
4. Maintain bypass of electric heater (FCV-383 open, FCV-384 closed)
5. Monitor drum pressure (PT-383) and temperature (TE-383) and all salt loop temperatures on Acurex
6. Pulse salt flow through SGS by opening FCV-341 when any monitored Acurex temperature or TE-383 drops to 530<sup>0</sup>F (vary duration of pulse for different test runs)
7. Repeat step 6 for duration of test
8. SGS3 to SGS2; steam generator to normal diurnal shutdown

### Success Criteria:

- o Maintained warm diurnal shutdown condition for at least 6 hours using pulsed salt flow
- o Collected specified data for comparison with baseline case

Primary Data Requirements:

- o Ambient air temperature, barometric pressure, relative humidity, wind speed and direction

FOLLOWING DATA WILL BE TAKEN CONTINUOUSLY THROUGH TEST AT 1 MIN. INTERVALS

- o SGS salt lines, valve, and equipment shell temperatures on Acurex data logger (channels 200 through 274)
- o Cold salt storage tank level (LT-281)
- o Cold salt storage tank temperatures (TE-281, TE-282, and TE-283)
- o Cold salt sump pump temperature (TE-286)
- o Cold salt sump pump level (LT-201)
- o Superheater salt inlet temperature (TE-382)
- o Superheater salt inlet pressure (PT-382)
- o Evaporator salt inlet temperature (TE-301)
- o Evaporator salt outlet temperature (TE-384)
- o Evaporator salt outlet pressure (PT-384)
- o Superheater outlet steam pressure (PT-321)
- o Steam drum temperature (TE-383)
- o Steam drum pressure (PT-383)
- o Steam drum level (LT-311)

DATA TO BE RECORDED MANUALLY

- o Time, duration and current readings for salt pump operation
- o All SGS heat trace current readings
- o Current reading for BWCP

## 5.7 TEST II-6 - OPTIMUM OPERATING STRATEGY DEVELOPMENT

### Description:

- o Operate full MSEE to collect maximum net energy within the operating constraints identified in the preceding five tests

### Objectives:

- o Develop operating strategy which maximizes net plant output
- o Develop data to be used to specify requirements for plant configuration, components and controls which would improve net plant output

### Pretest Conditions:

- o To be determined from prior tests

### Test Sequence:

- o To be determined from prior tests

### Success Criteria:

- o Developed optimum operating strategy
- o Obtained data for improvement of plant output

### Primary Data Requirements:

#### DATA TO BE RECORDED AT 1 MINUTE INTERVALS

- o Pyroheliometer readings
- o Receiver salt inlet temperature (TE-101)
- o Receiver salt outlet temperature (TE-102)
- o Receiver salt flow rate (FT-101)
- o Downcomer salt exit temperature (TE-161)
- o Hot salt storage tank level (LT-291)
- o Hot salt storage tank temperatures (TE-291, TE-292, and TE-293)
- o Cold salt storage tank level (LT-281)
- o Cold salt storage tank temperatures (TE-281, TE-282, and TE-283)
- o SGS cold salt flow rate (FT-382)

- o SGS total salt flow rate (FT-321)
- o Superheater salt inlet temperature (TE-382)
- o Superheater salt inlet pressure (PT-382)
- o Evaporator salt inlet temperature (TE-301)
- o Evaporator salt outlet temperature (TE-384)
- o Evaporator salt outlet pressure (PT-384)
- o Feedwater flow rate (FT-411)
- o Feedwater temperature (TE-386)
- o Feedwater pressure (PT-386)
- o SGS steam exit temperature (TE-332)
- o SGS steam exit pressure (PT-321)
- o SGS steam exit flow rate (FT-311)
- o Turbine inlet steam temperature (TE-583)
- o Turbine inlet steam pressure (PT-581)
- o Condenser steam pressure (PT-502)
- o Deaerator pressure (PT-432)
- o Deaerator temperature (TE-451)
- o Generator output voltage (ET-581)
- o Generator speed (ST-582)
- o Generator output wattage (JT-581)
- o Generator current (IT-581)
- o Generator VARS (VT-581)
- o Generator power factor (PFT-581)

DATA TO BE RECORDED MANUALLY

- o Pyroheliometer readings
- o Ambient air temperature, barometric pressure, relative humidity, wind speed and direction
- o Number of heliostats on target
- o Receiver subsystem heat trace currents readings
- o TSS heat trace currents readings
- o SGS heat trace currents readings
- o HRFS heater currents readings
- o Receiver subsystem motor currents
- o TSS motor currents
- o SGS motor currents
- o HRFS motor currents
- o EPGS motor currents
- o Turbine outlet steam temperature (TI-581)

## 5.8 TEST II-7 - RECEIVER COLD FLOW

### Description:

- o Use warm-up heliostats on the receiver and flow cold salt through the receiver back to the cold salt tank.

### Objectives:

- o Verify operation of receiver loop equipment, controls, and EPS
- o Confirm that surge tank provides emergency coolant to the receiver under all conditions.
- o Confirm procedures to accomplish start-up, shutdown, and emergency shutdown.
- o Confirm operation and interfaces of data system.

### Pretest Conditions:

- o RS2; receiver drained with trace heat on
- o TSS2; hot and cold salt tanks warm and ready for operation
- o SGS not applicable
- o EPGS not applicable

### Test Sequence:

1. RS2 to RS3; pre-test checklists to warm-up heliostats
2. RS3 to RS4; warm-up heliostats to cold flow through receiver
3. RS4 to RS5; cold flow through receiver with receiver door closed
4. Increase flow to 30%, stabilize and confirm level controls of hot and cold surge tanks
5. Increase flow to 50%, restabilize and reconfirm level controls
6. Increase flow to 100%, restabilize and reconfirm level controls
7. RS5 to RS2; cold flow through receiver to receiver drained, confirm shutdown
8. Repeat steps 1 and 2
9. Increase flow to 100%, stabilize and confirm level controls of hot and cold surge tanks
10. Initiate EPS trip by shutting off salt pumps. Confirm conditions of system following trip.
11. Complete transition to shutdown (RS2).

Success Criteria:

- o Successful operation of equipment and controls
- o Safe shutdown by EPS
- o Data system operational

Primary Data Requirements:

- o Ambient air temperature, barometric pressure, relative humidity, wind speed and direction
- o Number of heliostats on target

DATA TO BE LOGGED THROUGH TEST

- o Cold salt storage tank heat trace currents
- o Receiver heat trace currents
- o Receiver hot and cold surge tank heat trace currents
- o Riser and downcomer heat trace currents
- o Cold salt pump and cold salt booster pump heat trace currents

DATA TO BE RECORDED ON 2 MIN UPDATES

- o Pyroheliometer readings
- o Cold salt pump outlet pressure (PT-280)
- o Boost pump outlet pressure (PT-180)
- o Cold salt surge tank pressure (PT-182)
- o Receiver salt inlet pressure (PT-181)
- o Receiver salt inlet temperature (TE-101)
- o Receiver salt inlet flow rate (FT-101)
- o Receiver salt outlet temperature (TE-102)
- o Cold salt surge tank level (LT-151)
- o Hot salt surge tank level (LT-161)



## 5.9 TEST II-8 - RECEIVER STEADY STATE OPERATION

### Description:

- o Focus heliostats on the receiver and heat salt from the cold tank through the receiver and return it to the hot salt tank

### Objectives:

- o Verify operation of receiver loop equipment, controls, and EMCON alarms at rated receiver outlet temperature.
- o Confirm automatic switchover of TSS storage tanks accepting receiver outlet flow.

### Pretest Conditions:

- o RS2; receiver drained with trace heat on
- o TSS2; hot and cold salt tanks warm and ready for operation (90% salt inventory in cold tank)
- o SGS not applicable
- o EPGS not applicable

### Test Sequence:

1. RS2 to RS3; pre-test checklists to warm-up heliostats
2. RS3 to RS4; warm-up heliostats to cold flow through receiver
3. Increase flow to 50%
4. Set EMCON alarm on salt outlet temperature to 700<sup>o</sup>F
5. Increase heliostat field to 12.5% and stabilize
6. Reduce flow in 10% increments until salt outlet temperature exceeds 700<sup>o</sup>F
7. Confirm function of alarm
8. Reset EMCON alarm to 1060<sup>o</sup>F
9. Increase flow to 100%
10. RS4 to RS6; increase heliostat field to 25% in 12.5% increments
11. Stabilize and confirm salt outlet temperature
12. Reduce flow to 50%
13. Stabilize and confirm salt outlet temperature and flow switchover to hot tank

14. Increase flow back to 100%
15. Stabilize and confirm salt outlet temp and flow switchback to cold tank
16. Increase heliostat field to 50% in 12.5% increments
17. Stabilize and confirm salt outlet temperature and flow switchover to hot tank
18. RS6 to RS7; input receiver outlet salt temperature setpoint of 850<sup>o</sup>F and stabilize
19. Increase setpoint to 950<sup>o</sup>F and stabilize
20. Increase heliostat field to 75% in 12.5% increments and stabilize
21. Increase setpoint to 1050<sup>o</sup>F and stabilize
22. Increase heliostat field to 100% in 12.5% increments and stabilize
23. RS7 to RS2; full flow temperature control to shutdown

Success Criteria:

- o Successful operation of equipment and controls
- o Successful automatic switchover of cold salt tank flow into hot salt tank flow
- o Confirmed functioning of receiver outlet temperature alarm

Primary Data Requirements:

- o Ambient air temperature, barometric pressure, relative humidity, wind speed and direction

DATA TO BE LOGGED THROUGHOUT TEST

- o Number of heliostats on target
- o Receiver subsystem heat trace circuits currents
- o TSS heat trace circuits currents
- o Cold sump pump and cold salt boost pump currents

DATA TO BE CONTINUOUSLY RECORDED AT 2 MIN. INTERVALS

- o Pyroheliometer readings
- o Receiver salt inlet temperature (TE-101)
- o Receiver salt inlet pressure (PT-181)
- o Receiver salt outlet temperature (TE-102)

- o Receiver back tube temperatures  
(TE-103 through TE-120, and TE-131 through TE-148)
- o Cold salt surge tank pressure (PT-182)
- o Cold salt surge tank temperature (TE-182)
- o Cold salt surge tank level (LT-151)
- o Hot salt surge tank temperature (TE-183)
- o Hot salt surge tank level (LT-161)
- o Downcomer salt exit temperature (TE-161)
- o Cold salt storage tank level (LT-281)
- o Cold salt storage tank temperatures  
(TE-281, TE-282, and TE-283)
- o Hot salt storage tank level (LT-291)
- o Hot salt storage tank temperatures  
(TE-291, TE-292, and TE-293)
- o Cold salt pump outlet pressure (PT-281)
- o Cold salt boost pump outlet pressure (PT-180)

## 5.10 TEST II - 9 - RECEIVER OPERATION WITH SIMULATED (SLOW) CLOUD

### Description:

- o During receiver loop operation, ramp heliostats off of the receiver and back on.

### Objectives:

- o Verify system operation through simulated cloud passage
- o Confirm control stability through transients

### Pretest Conditions:

- o RS2; Receiver drained with trace heat on
- o TSS2; Hot and cold salt tanks warm and ready for operation (at least 70% salt inventory in cold tank)
- o SGS Not applicable
- o EPGS Not applicable

### Test Sequence:

1. RS2 to RS3; pre-test checklists to warm-up heliostats
2. RS3 to RS4; warm-up heliostats to cold flow through receiver
3. Increase flow to 100%
4. RS4 to RS6; increase heliostat field to 50% in 12.5% increments
5. RS6 to RS7; input receiver outlet salt temperature setpoint to 950 F and stabilize
6. Decrease heliostat field to 25% in two steps of 12.5% per two minutes and stabilize
7. Increase heliostat field to 50% in two steps of 12.5% per two minutes and stabilize
8. RS7 to RS6; increase flow to 100%
9. Increase heliostat field to 75% in increments of 12.5% per 2 minutes
10. RS6 to RS7; input receiver outlet salt temperature setpoint of 950 F and stabilize
11. Decrease heliostat field to 25% in increments of 12.5% per two minutes and stabilize
12. Increase heliostat field back to 75% at 12.5% per two minutes and stabilize
13. RS7 to RS6; increase flow to 100%
14. Increase heliostat field to 100% in increments of 12.5% per two minutes

15. RS6 to RS7; input receiver outlet salt temperature setpoint of 1050 F and stabilize
16. Decrease heliostat field to 25% in increments of 12.5% per two minutes and stabilize
17. Increase heliostat field back to 100% at a rate of 12.5% per two minutes and stabilize
18. RS7 to RS2; full flow temperature control to shutdown

Success Criteria:

- o Successful operation of equipment
- o Maintains control stability through transient conditions

Primary Data Requirements:

THESE DATA SHOULD BE RECORDED AT 2 MIN. INTERVALS

- o Pyroheliometer readings
- o Receiver salt inlet temperature (TE-101)
- o Receiver salt inlet pressure (PT-181)
- o Receiver salt outlet temperature (TE-102)
- o Receiver back tube temperatures  
(TE-103 through TE-120 and TE-131 through TE-148)
- o Receiver salt flow control valve commanded position (IE-101, IE-102) and actual position (ZT-101, XT-102)
- o Receiver salt flow rate (FT-101)
- o Cold salt surge tank level (LT-151)
- o Riser salt flow control valve commanded position (IE-151) and actual position (ZT-151)
- o Hot salt surge tank level (LT-161)
- o Downcomer salt flow control valves commanded positions (IE-161, IE-162) and actual positions (ZT-161, ZT-162)
- o Downcomer salt exit temperature (TE-161)
- o Cold salt storage tank level (LT-281)
- o Cold salt storage tank temperatures  
(TE-281, TE-282, and TE-283)
- o Hot salt storage tank level (LT-291)

- o Hot salt storage tank temperatures  
(TE-291, TE-292, and TE-293)
- o Cold sump level (LT-201)
- o Cold sump level control valve positions commanded (IE-201) and actual  
(ZT-201)

RECORD THESE DATA IN TABLES

- o Number of heliostats on target
- o Ambient air temperature, barometric pressure, relative humidity, wind  
speed and direction

## 5.11 TEST II-10 - THERMAL STORAGE CHARGING WITH PROPANE HEATER

### Description:

- o Charge the hot salt tank with hot salt using the propane heater

### Objectives:

- o Verify operation of propane heater loop to provide hot salt to TSS hot tank

### Pretest Conditions:

- o RS not applicable (booster pump off, sump and lines warm and FCV-151 closed)
- o TSS2; hot and cold salt tanks warm and ready for operation (at least 50% salt inventory in cold tank)
- o SGS not applicable
- o EPGS not applicable

### Test Sequence:

1. TSS2 to TSS3; pre-test checklists to charging hot salt tank using propane heater
2. Charge hot tank to selected level and temperature
3. TSS3 to TSS2; charging hot salt tank to shutdown

### Success Criteria:

- o Successful operation of propane heater and controls
- o Salt flow from cold tank through heater to hot tank
- o Data system operational

### Primary Data Requirements:

- o Record ambient air temperature, barometric pressure, relative humidity, wind speed and direction

DATA TO BE CONTINUOUSLY RECORDED AT 2 MIN. INTERVALS

- o Cold salt storage tank level (LT-281)
- o Cold salt storage tank temperatures  
(TE-281, TE-282, and TE-283)
- o Hot salt storage tank level (LT-291)
- o Hot salt storage tank temperatures  
(TE-291, TE-292, and TE-293)



Success Criteria:

- o Successful operation of equipment and controls
- o Safe shutdown by EPS
- o Data system operational

Primary Data Requirements:

- o Record ambient air temperature, barometric pressure, relative humidity, wind speed and direction

DATA TO BE CONTINUOUSLY RECORDED AT 2 MIN. INTERVALS

- o Hot salt storage tank level (LT-291)
- o Hot salt storage tank temperatures (TE-291, TE-292, and TE-293)
- o Cold salt storage tank level (LT-281)
- o Cold salt storage tank temperatures (TE-281, TE-282, and TE-283)
- o Superheater salt inlet temperature (TE-382)
- o Superheater salt inlet pressure (PT-382)
- o Evaporator salt inlet temperature (TE-301)
- o Evaporator salt outlet temperature (TE-384)
- o Evaporator salt outlet pressure (PT-384)
- o SGS cold salt flow rate (FT-382)
- o SGS total salt flow rate (FT-321)
- o SGS feedwater inlet pressure (PT-386)
- o SGS feedwater inlet temperature (TE-386)
- o SGS feedwater inlet flow rate (FT-411)
- o SGS steam exit temperature (TE-332)
- o SGS steam exit pressure (PT-321)
- o SGS steam exit flow rate (FT-311)
- o Attemperator steam flow rate (FT-381)
- o Superheater exit steam temperature (TE-331)
- o Steam drum pressure (PT-385)
- o Steam drum temperature (TE-383)
- o Steam drum level (LT-311)

## 5.12 TEST II-11- STEAM GENERATOR AND HRFS STEADY STATE OPERATIONS

### Description:

- o Use hot salt from TSS hot tank to generate steam using SGS; reject through HRFS.

### Objectives:

- o Verify operation of SGS using hot salt from TSS.
- o Verify operation of HRFS to provide feedwater to SGS and to reject heat
- o Verify controls of these operations.
- o Verify that EPS functions and safes the system.
- o Confirm procedures to accomplish start-up, shutdown and emergency shutdown
- o Confirm operation and interfaces of data system.

### Pretest Conditions:

- o RS; Not applicable
- o TSS2; Hot and cold salt tanks warm and ready for operation (at least 60% salt inventory in hot tank and at least 30% in cold tank)
- o SGS2; SGS warm and salt drained (diurnal shutdown)
- o EPGS; Not applicable

### Test Sequence:

1. SGS2 to SGS3; warm and salt drained to cold salt flow through SGS and stabilize
2. SGS3 to SGS4; warm standby to operating in boiler following mode
3. Stabilize at 30% of rated output
4. Adjust steam drum level set point to high-high level (to initiate EPS trip)
5. Confirm EPS trip and confirm condition of system
6. Restart HRFS feedwater pump
7. Restart SGS and stabilize at 30% of rated output
8. Increase to 60% of rated output and stabilize
9. Increase to 100% of rated output and stabilize
10. SGS4 to SGS2; SGS operating in boiler following control to diurnal shutdown

## 5.13 TEST II-12- OPERATION OF FULL ELECTRIC LOOP

### Description:

- o Use hot salt from TSS to generate steam.
- o Flow steam through EPGS at various loads to generate electricity.

### Objectives:

- o Verify operation of turbine using steam from SGS, heat rejection through HRFS, and all auxiliary circuits.
- o Verify synchronization of turbine generator with utility grid
- o Confirm procedures for all operations including emergency shutdown
- o Confirm operation at 110% of rated output

### Pretest Conditions:

- o TSS2; hot and cold salt tanks warm and ready for operation (at least 60% salt inventory in hot tank at 950°F)
- o SGS2; SGS warm and salt drained (diurnal shutdown)
- o EPGS2; EPGS pumps on (turbine standby)

### Test Sequence:

1. SGS2 to SGS4; diurnal shutdown to SGS operating in automatic boiler following mode at 30% of rated output
2. EPGS2 to EPGS3; EPGS pumps on to operating in EPGS standby
3. EPGS3 to EPGS4; operating EPGS standby to operating EPGS on-line
4. Increase power to 225 kW<sub>e</sub> at a rate of 75 kW<sub>e</sub> per minute
5. SGS4 to SGS5; SGS operating in auto boiler following mode to operating in turbine following
6. Increase power from generator to 750 kW<sub>e</sub> at a rate of 75 kW<sub>e</sub> per minute and stabilize
7. Increase power to 825 kW<sub>e</sub> at a rate of 75 kW<sub>e</sub> per minute
8. Decrease power to 225 kW<sub>e</sub> at a rate of 75 kW<sub>e</sub> per minute
9. SGS5 to SGS4; SGS operating in turbine following to operating in auto boiler following
10. EPGS4 to EPGS2; decrease electric power to zero at 75 kW<sub>e</sub> per minute
11. SGS4 to SGS2; SGS operating in auto boiler following to diurnal
12. EPGS2 to EPGS1; EPGS pumps on to shutdown

### Success Criteria:

- o Successful operation of equipment and control
- o Data system operational

### Primary Data Requirements

#### DATA TO BE CONTINUOUSLY RECORDED AT 2 MIN. INTERVALS

- o Record air temperature, barometric pressure, relative humidity, wind speed and direction
- o Hot salt storage tank level (LT-291)
- o Hot salt storage tank temperatures (TE-291, TE-292, and TE-293)
- o Cold salt storage tank level (LT-281)
- o Cold salt storage tank temperatures (TE-281, TE-282, and TE-283)
- o Superheater salt inlet pressure (PT-382)
- o Superheater salt inlet temperature (TE-382)
- o Evaporator salt inlet temperature (TE-301)
- o Evaporator salt outlet pressure (PT-384)
- o Evaporator salt outlet temperature (TE-384)
- o SGS cold salt flow rate (FT-382)
- o SGS total salt flow rate (FT-321)
- o SGS feedwater flow rate (FT-411)
- o SGS feedwater temperature (TE-386)
- o SGS feedwater pressure (PT-386)
- o SGS outlet steam flow rate (FT311)
- o SGS outlet steam temperature (TE-332)
- o SGS outlet steam pressure (PT-321)
- o Steam drum level (LT-311)
- o Steam drum temperature (TE-383)
- o Steam drum pressure (PT-383)
- o Turbine steam inlet pressure (PT-581)
- o Turbine steam inlet temperature (TE-583)
- o Condensor steam pressure (PT-502)
- o Deaerator pressure (PT-432)

- o Deaerator temperature (TE-451)
- o Generator voltage (ET-581)
- o Generator output wattage (JT-581)
- o Generator current (IT-581)
- o Generator VARS (VT-581)
- o Generator power factor (PFT-581)
- o Generator speed (ST-582)

## 5.14 TEST II-13 - SYSTEM STEADY STATE OPERATION; (USING RECEIVER)

### Description:

- o With all subsystems operational and integrated, use full heliostat field to produce rated power in the receiver.
- o Use this hot salt to produce electricity.

### Objectives:

- o Confirm operation of full system through normal start-up, steady state, and shutdown operations.
- o Confirm subsystem interactions and interfaces
- o Verify MCS interlock automatic procedures
- o Confirm utility type operations

### Pretest Conditions:

- o RS2; receiver drained with trace heat on
- o TSS2; hot and cold salt tanks warm and ready for operation (at least 90% salt inventory in cold tank)
- o SGS2; SGS warm and salt drained (diurnal shutdown)
- o EPGS2; EPGS pumps on

### Test Sequence:

1. RS2 to RS3; pre-test checklists to warm-up heliostats
2. RS3 to RS4; warm-up heliostats to cold flow through receiver
3. Increase flow to 100%
4. RS4 to RS6; increase heliostat field to 100% in increments of 12.5% per two minutes
5. RS6 to RS7; set receiver outlet salt temperature setpoint to 10509F and stabilize
6. Charge hot salt tank
7. SGS2 to SGS4; diurnal shutdown to SGS operating in automatic boiler following mode at 30% of rated output
8. EPGS2 to EPGS3; EPGS pumps on to operating in EPGS standby
9. EPGS3 to EPGS4; operating EPGS standby to operating EPGS on-line
10. Increase power to 225 kW<sub>e</sub> at a rate of 75 kW<sub>e</sub> per minute
11. SGS4 to SGS5; SGS operating in boiler following mode to operating in turbine following mode

12. Increase power from generator to 750 kW<sub>e</sub> at a rate of 75 kW<sub>e</sub> per minute and stabilize
13. SGS5 to SGS4; SGS operating in turbine following to operating in auto boiler following
14. EPGS4 to EPGS2; decrease power from generator to zero at a rate of 75 kW<sub>e</sub> per minute to turbine
15. SGS4 to SGS2; SGS operating in auto boiler following to diurnal shutdown
16. EPGS2 to EPGS1; EPGS pumps on to shutdown
17. RS7 to RS2; Full flow temperature control to shutdown

Success Criteria:

- o Successful operation of all subsystems
- o Data system operational

Primary Data Requirements:

- o Record ambient air temperature, barometric pressure, relative humidity, wind speed and direction

DATA TO BE CONTINUOUSLY RECORDED AT 2 MIN. INTERVALS

- o Pyroheliometer reading
- o Receiver salt inlet temperature (TE-101)
- o Receiver salt inlet pressure (PT-181)
- o Receiver salt outlet temperature (TE-102)
- o Receiver salt flow (FT-101)
- o Receiver salt flow control valve positions
  - Commanded (IE-101, IE-102)
  - Actual (ZT-101, ZT-102)
- o Cold salt surge tank temperature (TE-182)
- o Cold salt surge tank level (LT-151)
- o Cold salt surge tank pressure (PT-182)
- o Hot salt surge tank temperature (TE-183)
- o Hot salt surge tank level (LT-161)
- o Downcomer salt exit temperature (TE-161)
- o Hot salt storage tank level (LT-291)
- o Hot salt storage tank temperatures (TE-291, TE-292, and TE-293)

- o Cold salt storage tank level (LT-281)
- o Cold salt storage tank temperatures (TE-281, TE-282, and TE-283)
- o Superheater salt inlet temperature (TE-382)
- o Superheater salt inlet pressure (PT-382)
- o Evaporator salt exit temperature (TE-384)
- o Evaporator salt exit pressure (PT-384)
- o SGS cold salt flow rate (FT-382)
- o SGS total salt flow rate (FT-321)
- o SGS feedwater inlet pressure (PT-386)
- o SGS feedwater inlet temperature (TE-386)
- o SGS feedwater inlet flow rate (FT-411)
- o SGS steam exit pressure (PT-321)
- o SGS steam exit temperature (TE-332)
- o SGS steam exit flow rate (FT-381)
- o Turbine steam inlet pressure (PT-581)
- o Turbine steam inlet temperature (TE-583)
- o Condensor steam pressure (PT-502)
- o Deaerator pressure (PT-432)
- o Deaerator temperature (TE-451)
- o Generator voltage (ET-581)
- o Generator output wattage (JT-581)
- o Generator current (IE-581)
- o Generator VARS (VT-581)
- o Generator power factor (PFT-581)
- o Generator speed (ST-582)



## 5.15 TEST II-14- HYBRID OPERATION (USING PROPANE HEATER)

### Description:

- o With all subsystems operational and integrated, except no insulation for the receiver, use the propane heater to generate hot salt to the hot tank
- o Use this hot salt to produce electricity

### Objectives:

- o Confirm operation of full system through normal start-up, steady state, and shutdown operations.
- o Confirm subsystem interactions and interfaces
- o Verify MCS interlock automatic procedures

### Pretest Conditions:

- o RS not applicable
- o TSS2; hot and cold salt tanks warm and ready for operation (at least 90% salt inventory in cold tank)
- o SGS2; SGS warm and salt drained (diurnal shutdown)
- o EPG2; turbine standby - pumps on

### Test Sequence:

1. TSS2 to TSS3; Pre-test checklists to charging hot salt tank using propane heater
2. SGS2 to SGS3; diurnal shutdown to SGS operating in automatic boiler following mode at 30% of rated output
3. EPG2 to EPG3; EPG pumps on to operating in EPG standby
4. EPG3 to EPG4; operating EPG standby to operating EPG on-line
5. Increase power to 225 kW<sub>e</sub> at a rate of 75 kW<sub>e</sub> per minute
6. SGS4 to SGS5; SGS operating in auto boiler following mode to operating in turbine following
7. Increase power from generator to 750 kW<sub>e</sub> at a rate of 75 kW<sub>e</sub> per minute and stabilize

8. SGS5 to SGS4; SGS operating in turbine following to operating in auto boiler following
9. EPGS4 to EPGS2; decrease power from generator to zero at a rate of 75 kW<sub>e</sub> per minute to turbine
10. SGS4 to SGS2; SGS operating in auto boiler following to diurnal shutdown
11. TSS3 to TSS2; charging hot salt tank to shutdown
12. EPGS2 to EPGS1; EPGS pumps on to shutdown

Success Criteria:

- o Successful operation of all subsystems
- o Data system operational

Primary Data Requirements:

- o Ambient air temperature, barometric pressure, relative humidity, wind speed and direction

DATA TO BE CONTINUOUSLY RECORDED AT 2 MIN. INTERVALS

- o Hot salt storage tank level (LT-291)
- o Hot salt storage tank temperatures (TE-291, TE-292, and TE-293)
- o Cold salt storage tank level (LT-281)
- o Cold salt storage tank temperatures (TE-291, TE-292, and TE-293)
- o Superheater salt inlet pressure (PT-382)
- o Superheater salt inlet temperature (TE-382)
- o Evaporator salt outlet pressure (PT-384)
- o Evaporator salt outlet temperature (TE-384)
- o SGS cold salt flow rate (FT-382)
- o SGS total salt flow rate (FT-321)
- o SGS feedwater flow rate (FT-411)
- o SGS feedwater temperature (TE-386)
- o SGS feedwater pressure (PT-386)
- o SGS outlet steam flow rate (FT-311)
- o SGS outlet steam temperature (TE-332)

- o SGS outlet steam pressure (PT-321)
- o Steam drum level (LT-311)
- o Steam drum temperature (TE-383)
- o Steam drum pressure (PT-383)
- o Turbine steam inlet pressure (PT-581)
- o Turbine steam inlet temperature (TE-583)
- o Condensor steam pressure (PT-502)
- o Deaerator pressure (PT-432)
- o Deaerator temperature (TE-451)
- o Generator voltage (ET-581)
- o Generator output wattage (JT-581)
- o Generator current (IT-581)
- o Generator VARS (VT-581)
- o Generator power factor (PFT-581)
- o Generator speed (ST-582)

## 5.16 TEST II-15 - SALT PROPERTIES AND STABILITY (supplied by Olin)

### Description:

During the MSEE molten salt will be sampled and analyzed to determine if the composition of the molten salt has been altered. Both hot salt (900-1000°F) and cold salt (590°F) samples will be analyzed on a monthly basis.

### Test Objectives

The test objectives are:

- a. Determine if the salt composition has been altered (i.e., sodium - potassium ratio changed).
- b. Determine if new components are building up in the salt (i.e., corrosion products).
- c. Determine if new components are being formed in the salt (i.e., carbonates and hydroxide).

Components to be analyzed:

Ni, Fe, Al, Mo, Cr<sup>+3</sup>, Cr<sup>+6</sup>, Ca, Mg, Si, Cl, SO<sub>4</sub>, CO<sub>3</sub>, OH, NaNO<sub>2</sub>,  
NaNO<sub>3</sub>, KNO<sub>3</sub>, CU

### Test Description

The salt sampling will be performed twice a month throughout Phase II. Two samples will be obtained of the salt, a hot salt sample of the Olin corrosion test loop, and a cold salt sample from the cold salt storage tank. The salt samples will be shipped to Olin for analysis. Results of the salt analysis will be reported at 6-month intervals.

To verify analysis of the molten salt, one set of samples will be sent to an independent laboratory.

## 5.17 TEST II -16 - SALT CORROSION (supplied by Olin)

### Description

The corrosion loop has been placed in the salt loop to provide corrosion data of various metal alloys in molten salt service. The corrosion rates of the metal alloys with hot salt (900-1000°F) will be tested.

### Test Objectives

- a. Determine the corrosion rate of various metal alloys in hot molten salt service (900-1000°F).
- b. Determine the effects of thermal cycling on the corrosion rate of the metal alloys.
- c. Determine the effects of molten salt velocity on the corrosion rate of the metal alloys.

Alloys to be tested:

Stainless Steels 316L, 304L, 430

Incoloy 800

Inconel 600, 625, 690

### Test Description

The corrosion test loop will operate throughout Phase II of the MSEE. The test loop is integrated with the hot salt pump so the loop will operate while the hot salt pump operates. During Phase II one corrosion box will be removed from the test loop and the metal samples analyzed.

## Section 6 SCHEDULE AND PRIORITIES

The schedule for Phase II tests is shown on Figure 6-1. It is based on completing Phase I by May 14, 1984. In the event that Phase I completion is delayed, the Phase II program will be shifted accordingly.

The Phase II tests are scheduled so that all engineering tests are completed prior to operation by the utility operator teams. The Part A tests, MSEE characterization, are scheduled for 12 weeks assuming an equipment availability of 0.5 (exclusive of solar availability). Part B and Part C tests are then developed and used for a trial team of engineers from the sponsors. Part B and Part C tests, incorporating improvements from the trial session, are then repeated for each of the four utility operator teams. All utility team operations is scheduled to be completed by November 16, 1984.

The Part A tests are grouped to provide alternative tests in the event of cloudy weather where possible. The performance tests under II-1 and II-2 can be intermixed so that test II-1 would be performed on sunny days and II-2 on cloudy days. Similarly, the overnight conditioning tests can be adjusted to match the sun's availability.

Part D, Salt Characteristics, tests are conducted throughout Phase II.

Part A, MSEE Characteristics, and Part D, Salt Characteristics, have been given first priority in this test program. This is due to:

1. The need to develop data on the performance and operating capability of the MSEE to support the technology development program for utility-scale power plants utilizing molten salt.
2. The desire of the utility sponsors to see reasonably reliable, routine operation prior to committing operator teams.

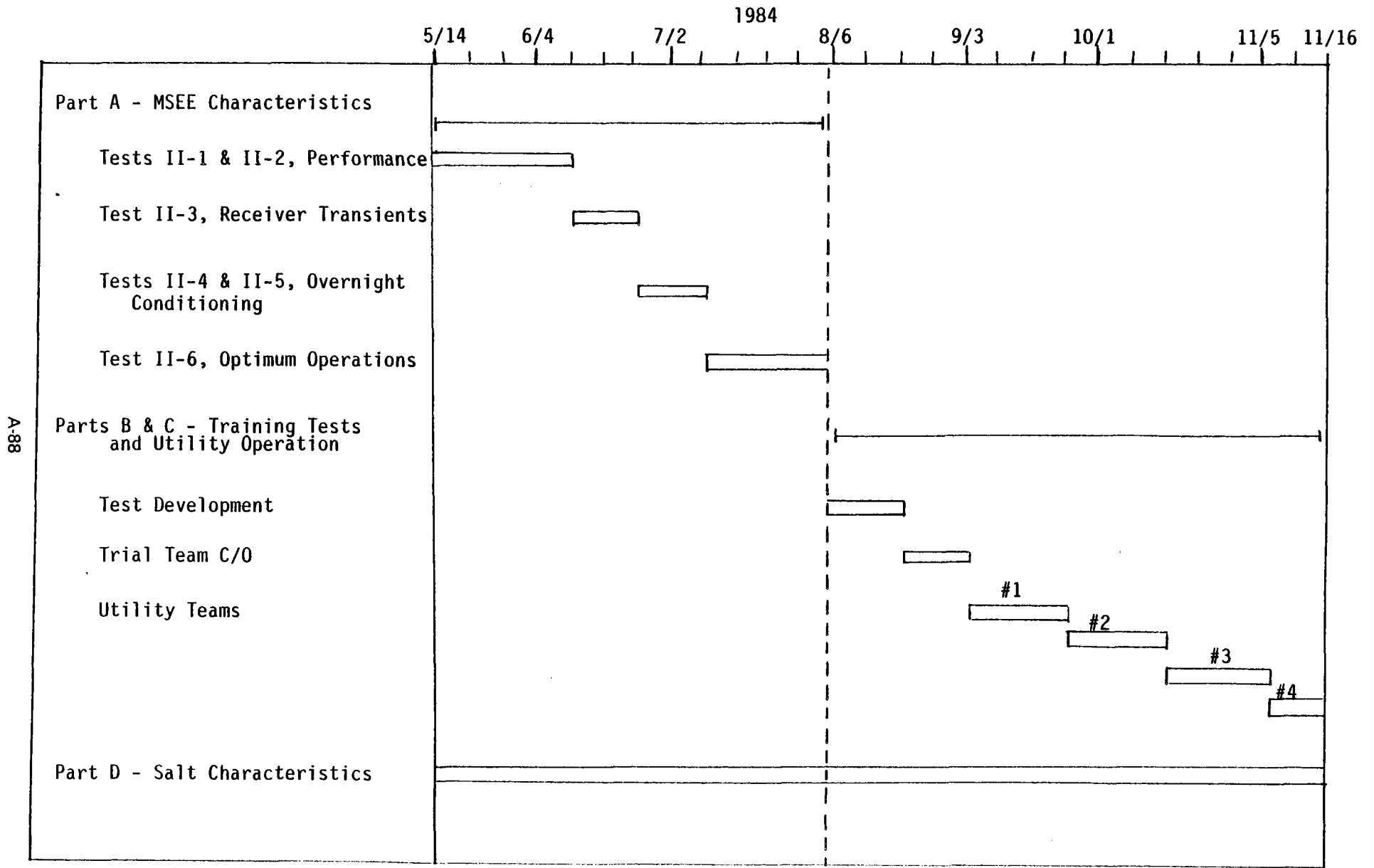

Figure 6-1. MSEE Phase II Test Schedule

Section 7  
TEST DOCUMENTATION

7.1 TEST RECORDS AND DAILY LOG

The Test Conductor shall maintain a chronological and historical record of all significant events that transpire during the test. Events are to be recorded on the spot and later extracted to become part of the test report. The Test Conductor shall also keep a daily log with details of test progress, anomalies, deviations, significant results, etc. Log entries shall be made on a continual basis while tests are in progress, and daily during test downtime.

Each utility operator will keep a log of his daily activities which will be turned in to the Test Conductor at the end of each day.

7.2 PREPARATION OF TECHNICAL MEMORANDUM

A test report documenting the results of the tests shall be prepared and shall include, but not be limited to, the following:

- A. Test hardware configuration
- B. Test objectives
- C. Description of test sequences
- D. List of equipment used
- E. Significant test data
- F. Analysis of test data



ADDENDUM B  
TEST PROCEDURES

COP #1 CONTROL ROOM PRETEST CHECKLIST

TEST DATE  
11/19/84

This Console operating procedure will be utilized to verify process control integrity prior to all tests. It is unnecessary to verify control integrity of subsystems not used (not applicable). This checklist shall be completed by the control room process console operator.

I. Test Description \_\_\_\_\_

		Start Time
II. Responsible operating personnel	Primary	Backup
Test Conductor (MDAC)	<u>Stan Saloff</u>	_____
Heliostat Operator	<u>Arleen Vance</u>	_____
Console Operator	<u>Evans/Nelson</u>	_____
Operation/Safety Engineer	<u>John Holmes</u>	_____
Subsystem Technicians		
RS	<u>Jerome Griego</u>	_____
TSS	<u>Matt Matthews</u>	_____
SGS	<u>Matt Matthews</u>	_____
HRFS	<u>Jay Holton</u>	_____
EPGS	<u>Jay Holton</u>	_____

COP #1 CONTROL ROOM PRETEST CHECKLIST

---

III. Safety Checklist

O/S

Complete this checklist for all operations.

1. Site occupants

A. Verify that all test personnel have been briefed on the scheduled test description, objectives, individual responsibilities, and expected response to emergencies \_\_\_\_\_

B. Communications established to all manned control points \_\_\_\_\_

C. Safety equipment in place:

1. OSHA protective gloves \_\_\_\_\_

2. Fire retardant coveralls \_\_\_\_\_

3. Hard hats/Face shields \_\_\_\_\_

4. Approved fire extinguishers \_\_\_\_\_

2. Solar only

A. "Test In Progress" lights on in the tower \_\_\_\_\_

B. Non-Test personnel informed and in secure location \_\_\_\_\_

C. Diesel-Generator on and frequency OK \_\_\_\_\_

D. Field monitor on call after solar start-up \_\_\_\_\_

E. Communications established \_\_\_\_\_

F. Tower top barricade up \_\_\_\_\_

G. Gates closed and posted with red lights or signs \_\_\_\_\_

H. Field clear and ready for start-up \_\_\_\_\_

3. Control Room locked \_\_\_\_\_

4. Beam up command shall be given only after above checklist is completed by O/S Engineer \_\_\_\_\_

<u>STEP</u>	<u>DESCRIPTION</u>	<u>VERIFICATION</u>
-------------	--------------------	---------------------

Notice

Four items that impact system start-up significantly and should be verified and/or corrected first are:

- a. Emcon operation
- b. Acurex temperatures (local heat trace control possible)
- c. D/D level and temp. (local fast fills possible)
- d. Steam drum level and temp. (local chem. feed op fill possible)

IV. MASTER CONTROL SUBSYSTEM

A. EMCON D/2 HOST START UP CHECKLIST

Complete this checklist for all operations.

1. Equipment powered up:

- a) Host cabinet
- b) Operator Console 1
- c) Operator Console 2
- d) (2) LA-120 Terminals
- e) VT-100 Terminal
- f) Tri-log printer

\_\_\_\_\_

2. Disk Packs (2) installed in drives, disk drives running with "READY" lamp lit.

\_\_\_\_\_

3. EMCON system booted and "START-UP" command file executed:

- a) Correct date and time
- b) Disk unit DLI mounted
- c) CCM, PCMs loaded (optional)
- d) EMCON host programs running

- |           |           |
|-----------|-----------|
| 1. SPNCOL | 5. CONSL2 |
| 2. POWER  | 6. CONSL1 |
| 3. ALRMMX | 7. SYSMON |
| 4. ALARMS | 8. TRACKR |

\_\_\_\_\_

4. MSSND program executing when data logging display is required on the Auxiliary Data Logging/Display System.

\_\_\_\_\_

5. Unlock Console to allow activation of operational alarms and Receiver Control Algorithm.

\_\_\_\_\_

28 6. Enable general alarms by turning GAL on.

\_\_\_\_\_

COP #1 CONTROL ROOM PRETEST CHECKLIST

STEP	DESCRIPTION	VERIFICATION
B.	<u>ACUREX START-UP CHECKLIST</u> Complete this checklist for all operations using salt.	
	1. Equipment powered up:	
	a) Host chassis - Autodate Ten/50 b) Electrohome monitor c) GT-100 Terminal d) Texas Instruments 820 R0 Terminal	_____
	2. Tape Cassette loaded in host drive.	_____
	3. Recent (within 60 minutes) logout of temperatures available on TI printer.	Last Print Time
	4. Set scan rate to every 60 minutes.	_____
C.	<u>AUXILIARY DATA LOGGING/DISPLAY SYSTEM</u> Data acquisition checklist completion optional as required.	
	1. Equipment powered up:	
	a) H-P 1000 Cabinet b) H-P 2645 Terminal c) H-P 2621 Terminal d) Tektronix 4014 Terminal e) Tektronix 463 hard-copy unit f) (6) Display CRTs g) Versatec Video Copier h) Versatec Printer i) H-P 7925 Disc Drive	_____
	2. Disk pack installed in drive, disc drive running with "READY" lamp lit.	_____
	3. System booted: a) Correct date and time b) Transfer file IMSRP executed	_____
	4. MSPAS program executing when data logging/display is required and MSSN2 has been started on the EMCON host.	_____
	5. Following support programs available for execut:	
	a) MSRTP b) MSPSU c) MSDSD d) MSSLI through MSSL6 e) MSCDT	_____
	6. Label file used: _____	_____
	7. Data file used: _____	_____

COP #1 CONTROL ROOM PRETEST CHECKLIST

STEP	DESCRIPTION	VERIFICATION
D.	<u>NETWORK 90 SETUP CHECKLIST</u> Complete this checklist for operation with SGS.	
	1. Verify equipment powered up and operational.	
	a) Bailey PCU	
	b) Operator Interface Drive Unit	
	*c) Keyboard Console	
	*d) Printer	
	*These components may be turned off when not in use.	_____
V.	<u>RS - RECEIVER SUBSYSTEM</u> Complete this checklist for operation with Receiver.	
	1. Verify acceptable limits on winds (less than 30 MPH), solar insolation (above 600 W/m <sup>2</sup> ) and cloud condition (partly cloudy or clear).	_____
	2. Verify TV cameras are on and operational.	_____
	3. Verify the Control Room SCRAM and EPS power supplies behind Weather Monitor Panel are On and set at 24VDC.	_____
02	4. Open the Receiver cavity door upon the request of the RS technician for the RS pretest check. Reclose or leave open as required. (DR.OPN/CLS).	_____
07	5. Verify Emcon RS header temperatures are above 480°F. (TE-188 inoperable).	_____
	6. Verify the Acurex RS trace heaters are operating and the temperatures are above 480°F (Table A). NOTE EXCEPTIONS. If required, heat tracing control can be taken over locally at the module control room.	_____
	7. Align/verify the following valve alignment; confirm valve temps are acceptable before moving. (to avoid bellows damage) Coordinate with Receiver technician. RCK 1 & RCK 3 may be used to auto align these, turning itself off when complete.	_____

Time

	Valve	Description	Position		
—	FCV-101	Salt flow control	Man/Open/N		
01	RCK1	FCV-102	Salt flow control	Man/Open/N	
		FCV-180-T89	Drain valves	On/Open/N	(ZSH180-189 On) 08
		*FCV-190-T98	Purge valves	On/Open/N	(ZSH190-198 On) 09
04	RCK3	CSP.EN	Enable CSP control	On	
		BP.EN	Enable BP control	On	

\*Purge valve group control only functional to open valves, will not close valves.

COP #1 CONTROL ROOM PRETEST CHECKLIST

STEP	DESCRIPTION	VERIFICATION																																													
VI.	TSS - THERMAL STORAGE SUBSYSTEM																																														
	Complete this checklist for all operations using salt.																																														
	1. Verify that the Acurex TSS trace heaters are operating and the temperatures are above 480°F (Table B). NOTE EXCEPTIONS. If req'd, heat tracing control can be controlled locally at salt storage control building.	_____ Time																																													
	2. If operating Propane Heater without SGS, verify that these Acurex SGS inlet trace heaters are above 480°F (Ref. Table C):	_____																																													
	<table border="1"> <thead> <tr> <th>Channel</th> <th>Channel</th> <th>Local Temp. Verific.</th> </tr> </thead> <tbody> <tr> <td>204</td> <td>255</td> <td>FCV-241</td> </tr> <tr> <td>205</td> <td>256</td> <td></td> </tr> <tr> <td>206</td> <td>257</td> <td></td> </tr> <tr> <td></td> <td>258</td> <td></td> </tr> </tbody> </table>	Channel	Channel	Local Temp. Verific.	204	255	FCV-241	205	256		206	257			258																																
Channel	Channel	Local Temp. Verific.																																													
204	255	FCV-241																																													
205	256																																														
206	257																																														
	258																																														
	3. Verify salt levels in storage tanks and sumps are commensurate with test requirements	_____																																													
—	LT-201 Cold Sump _____ in. (60" max)**@ _____ °F (Acurex Chan 124,125)																																														
03	LT-281 Cold Tank _____ in. (40" min)* @ _____ °F (Acurex Chan 110-112)																																														
—	LT-221 Hot Sump _____ in. (43" max)**@ _____ °F (Acurex Chan 126,127)																																														
—	LT-291 Hot Tank _____ in. @ _____ °F (Acurex Chan 134-136)																																														
	*Minimum level req'd to maintain cold sump level during fill operation																																														
	**Maximum levels automatically close FCV-211 and 231 thru Emcon and lockout may overridden by turning OVR3 on. Maximum levels require vent checks; advise technician.																																														
	4. Align/verify the following valves for system operation with RS, and SGS. Confirm valve temps are accept. before moving. Coordinate with thermal storage technician. TCK 'ON" may be used to auto align these, turning itself off when complete.																																														
	<table border="1"> <thead> <tr> <th>Valve</th> <th>Description</th> <th>Position</th> </tr> </thead> <tbody> <tr> <td>*FCV-151</td> <td>CST Level Control</td> <td>Man/Closed/N</td> </tr> <tr> <td>02</td> <td>FCV-161 HST Level Control(Hot)</td> <td>Man/Closed/N</td> </tr> <tr> <td></td> <td>FCV-162 HST Level Control(Cold)</td> <td>Man/Closed/N</td> </tr> <tr> <td></td> <td>FCV-199 Bypass Isolation valve</td> <td>Off/Open /N (ZSH199 or</td> </tr> <tr> <td>—</td> <td>FCV-201 Cold Sump Level Control</td> <td>Auto SP 23"/Closed/N</td> </tr> <tr> <td>04</td> <td>FCV-211 Cold Sump Isolation Valve</td> <td>Off/Closed/Locked (ZSL211 or</td> </tr> <tr> <td></td> <td>FCV-221 Hot Sump Level Control</td> <td>Auto SP 20"/Closed/N</td> </tr> <tr> <td></td> <td>FCV-231 Hot Sump Isolation Valve</td> <td>Off/Closed/Locked (ZSL231 or</td> </tr> <tr> <td>05</td> <td>FCV-241 Propane Heater Inlet</td> <td>Man/Closed/Locked</td> </tr> <tr> <td></td> <td>FCV-242 Propane Heater Isolation</td> <td>Off/Closed/Locked (ZSL242 or</td> </tr> <tr> <td>—</td> <td>FCV-301 Bypass Salt Flow</td> <td>Closed/N (MAN on, SP Auto 0%</td> </tr> <tr> <td>13</td> <td>FCV-341 Cold Salt Control Valve</td> <td>Closed/N (MAN on, SP Auto 0%</td> </tr> <tr> <td></td> <td>FCV-351 Hot Salt Control Valve</td> <td>Closed/N (MAN on, SP Auto 0%</td> </tr> <tr> <td>04</td> <td>CSP.EN Enable CSP Control</td> <td>On</td> </tr> </tbody> </table>	Valve	Description	Position	*FCV-151	CST Level Control	Man/Closed/N	02	FCV-161 HST Level Control(Hot)	Man/Closed/N		FCV-162 HST Level Control(Cold)	Man/Closed/N		FCV-199 Bypass Isolation valve	Off/Open /N (ZSH199 or	—	FCV-201 Cold Sump Level Control	Auto SP 23"/Closed/N	04	FCV-211 Cold Sump Isolation Valve	Off/Closed/Locked (ZSL211 or		FCV-221 Hot Sump Level Control	Auto SP 20"/Closed/N		FCV-231 Hot Sump Isolation Valve	Off/Closed/Locked (ZSL231 or	05	FCV-241 Propane Heater Inlet	Man/Closed/Locked		FCV-242 Propane Heater Isolation	Off/Closed/Locked (ZSL242 or	—	FCV-301 Bypass Salt Flow	Closed/N (MAN on, SP Auto 0%	13	FCV-341 Cold Salt Control Valve	Closed/N (MAN on, SP Auto 0%		FCV-351 Hot Salt Control Valve	Closed/N (MAN on, SP Auto 0%	04	CSP.EN Enable CSP Control	On	
Valve	Description	Position																																													
*FCV-151	CST Level Control	Man/Closed/N																																													
02	FCV-161 HST Level Control(Hot)	Man/Closed/N																																													
	FCV-162 HST Level Control(Cold)	Man/Closed/N																																													
	FCV-199 Bypass Isolation valve	Off/Open /N (ZSH199 or																																													
—	FCV-201 Cold Sump Level Control	Auto SP 23"/Closed/N																																													
04	FCV-211 Cold Sump Isolation Valve	Off/Closed/Locked (ZSL211 or																																													
	FCV-221 Hot Sump Level Control	Auto SP 20"/Closed/N																																													
	FCV-231 Hot Sump Isolation Valve	Off/Closed/Locked (ZSL231 or																																													
05	FCV-241 Propane Heater Inlet	Man/Closed/Locked																																													
	FCV-242 Propane Heater Isolation	Off/Closed/Locked (ZSL242 or																																													
—	FCV-301 Bypass Salt Flow	Closed/N (MAN on, SP Auto 0%																																													
13	FCV-341 Cold Salt Control Valve	Closed/N (MAN on, SP Auto 0%																																													
	FCV-351 Hot Salt Control Valve	Closed/N (MAN on, SP Auto 0%																																													
04	CSP.EN Enable CSP Control	On																																													

\*Bad signal (blue) can indicate EPS closure. Clear trips and reset EPS1 & EPS3 regain control.

COP #1 CONTROL ROOM PRETEST CHECKLIST

<u>STEP</u>	<u>DESCRIPTION</u>	<u>VERIFICATION</u>
5.	For operation with Propane Heater instead of Receiver OR for SGS alone, Modify the valve alignment of step 4 as follows:	_____
	<u>Valve</u> <u>Position</u>	
<u>02</u>	FCV-162	Man/Open/N
<u>05</u>	FCV-242	Neutral
6.	For operation without SGS, Modify the valve alignment of step 4 as follows:	_____
	<u>Valve</u> <u>Position</u>	
13	FCV-301	Locked
	FCV-341	Locked
04	7. Verify pump bearing temp's are less than 190°F (TE 180, 286, & 387 on EMCON) and alarms on.	_____

VII. SGS - STEAM GENERATION SUBSYSTEM

Complete this checklist for operation with SGS.

0.	Verify drum level is above -2" if hot either locally fill with chem. feed pump or start HRFS and fill (per step 3)	_____
1.	Verify that the Acurex SGS trace heaters are operating and the temperatures are above 480°F (Table C). NOTE EXCEPTIONS. If required, heat tracing control can be taken over locally at the salt storage control building Acurex cabinet back.	_____
2.	Align/verify the following valve positions. Confirm valve temps are accept. before moving. Coordinate with thermal storage technician. All SGS control valve MAN signals should be On. (Emcon commands not applicable from Net 90) SCK 'ON' may be used to auto align these, turning itself off when complete.	_____

Time

	<u>Emcon Command</u>	<u>Valve Description</u>	<u>Position</u>
—	SP-321 Auto 100%/MAN.321 On	Main Salt Flow	Open
	SP-331 Auto 10%/MAN.331 on	Steam Attemp.	10% Open
13	FCV-38182 On/MAN.38182 On	Salt Drain	Open
	FCV-384 On/*MAN.384 On	Circ Htr Supply	Open
	FCV-383 Off/*MAN.383 On	Circ Htr Bypass	Closed
<u>04</u>	HSP.EN	Enable HSP Control	On

\*Open FCV-384 before closing FCV-383 to avoid SGS Pump and Heater Shut-off



OP #1 CONTROL ROOM PRETEST CHECKLIST

---

<u>STEP</u>	<u>DESCRIPTION</u>	<u>VERIFICATION</u>
	Complete the following steps after completing HRFS startup. (Presuming SGS is in Diurnal Shutdown).	
3.	If SGS F.W. inlet pipe temp. (Acurex Channel 132) is below 200°F, increase bridge pipe feedwater temperature: <ul style="list-style-type: none"> <li>a) Verify D/D TE-451 is above 250°F</li> <li>b) Advise the SGS technician to open the bridge feedwater drain HV-370, then open FCV-411 to 20% (Emcon MAN.411 on/SP Auto 20%)</li> <li>c) Verify Acurex channel 132 increases above 200°F (Approx 5 min after opening FCV-411)</li> <li>d. Reclose HV-370 and FCV-411</li> </ul>	_____ _____ _____ _____
4.	Verify drum level LT-311 is at an appropriate level for start-up. If drum level is below -2.0 inches; open HV-488, then open FCV-411 to 20% and fill to -2.0". Close FCV-411 and HV-488 to avoid FW leakage into drum.	_____
5.	Verify that the boiler water circulation pump (BWCP) <u>is</u> running (ZSHBCP). If it is <u>not</u> running: <ul style="list-style-type: none"> <li>a) Review overnight data to determine reason and correct.</li> <li>b) Start BWCP</li> <li>c) Start circulation heater (pulse EHAC.ON)</li> </ul>	_____
6.	If freezing ambient temperatures have been experienced, resolve any suspicious instr. transmitter readings with the SGS technician. Be skeptical of all readings until proven.	_____

COP #1 CONTROL ROOM PRETEST CHECKLIST

STEP	DESCRIPTION	VERIFICATION
------	-------------	--------------

VIII. HRFS - HEAT REJECTION AND FEEDWATER SUBSYSTEM

Complete this checklist for all water system operations.

0. Verify that D/D level is adequate (15" normal). Locally conduct a fast fill if required.
  
1. Set/Verify the following control devices in the listed positions: HCK 'ON' may be used to auto align these, turning itself off when complete.

Identifier	Description	Command	Position
GSTAT	D/D Press Enable	Off (PT-431 control)	N/A
EH1	D/D Heater 1 Enable	Off	N/A
EH2	D/D Heater 2 Enable	Off	N/A
H1	D/D Heater 1	Auto SP 250 °F	Not Enabled
H2	D/D Heater 2	Auto SP 250°F	Not Enabled
FCV-401	FWP Press Recirc	Auto SP 1250 psi	Closed
FCV-411	Feedwater Delivery	MAN.411 On/SP-411 AUTO 0%	Closed
FCV-421	FWH Steam Supply	Man	Closed
FCV-431	D/D Steam Inlet	Auto/Casc to PT-431	Closed
PT-431	Steam Line Press	Auto SP 1080 psi	N/A
PT-432	D/D Press	Auto SP 225 psi	N/A
FCV-432	SWHX Divert	Auto SP 233 psi	Open to Bypass
FCV-471	T-G Condensate Return	Auto SP 0%	Closed
FY-472	CMUP Stroke Positioner	Auto SP 0%	Closed
FCV-491	SGS Steam Delivery	Auto SP 900 psi	Closed
ZSL-501	Main Steam Stop micro	On	Closed
TCPMS	EPGS Control Mode	Off (local)	N/A
CF1.EN	Cooling Fan 1 Enable	On	N/A
CF2.EN	' ' 2 '	On	N/A
CF3.EN	' ' 3 '	On	N/A
CF4.EN	' ' 4 '	On	N/A
CF5.EN	' ' 5 '	On	N/A
CF6.EN	' ' 6 '	On	N/A
CFP.EN	Cycle Fill Pump	Enable	N/A
CMP.EN	Cond. Make-up Pump	'	N/A
CWP.EN	Cooling Water Pump	'	N/A
SWP.EN	Spray Water Pump	'	N/A
FWP.EN	Feed Water Pump	'	N/A

IX. EPGS ELECTRIC POWER GENERATION SUBSYSTEM

Complete this checklist for all turbine-generator operations.

1. Verify RGP Gen Breaker green (open) light is on.
  
2. Verify that the Sync switch handle has been procured from the MSEE key box if synch is to be completed or observed from the control room.

T/C	DESCRIPTION	ACUREX CHANNEL	T/C	DESCRIPTION	ACUREX CHANNEL
TEH-190	Purge Valve #1	000	TEH-157	Receiver Outlet-Heater R	027
TEH-191	Purge Valve #2	001	TEH-158	Receiver Outlet-Heater R	028
TEH-192	Purge Valve #3	002	TEH-153	Hot Surge Tank Inlet-Heater N	029
TEH-193	Purge Valve #4	003	TEH-159	Hot Surge Tank Outlet-Heater N	030
TEH-194	Purge Valve #5	004	TEH-152	Cold Surge Tank Inlet-Heater O	031
TEH-195	Purge Valve #6	005	TEH-156	Cold Surge Tank-Heater O	032
TEH-196	Purge Valve #7	006	TEH-150	Receiver Inlet-Heater P	033
TEH-197	Purge Valve #8	007	TEH-151	Receiver Inlet-Heater P	034
TEH-198	Purge Valve #9	008	TEH-162	FCV-101-Heater Q	035
TEH-180	Drain Valve #1	009	TEH-163	FCV-102-Heater Q	036
TEH-181	Drain Valve #2	010	TEH-154	Drain Line-Heater T	037
TEH-182	Drain Valve #3	011	TEH-155	Drain Line-Heater T	038
TEH-183	Drain Valve #4	<u>012</u>	TEH-166	Hot Surge-Heater U	039
TEH-184	Drain Valve #5	013	TEH-167	Hot Surge-Heater U	040
TEH-185	Drain Valve #6	014	TEH-164	Cold Surge-Heater V	041
TEH-186	Drain Valve #7	015 (Bad)	TEH-165	Cold Surge-Heater V	<u>042</u>
TEH-187	Drain Valve #8	016	TEH-131	Riser-Heater H	300
TEH-188	Drain Valve #9	017	TEH-133	Riser-Heater I	301
TEH-189	Drain Valve #10	018	TEH-134	Riser-Heater I	302
TEH-160	Purge Line-Heater S	019	TEH-135	Riser-Heater J	303
TEH-161	Purge Line-Heater S	020	TEH-136	Riser-Heater J	304
TEH-176	Drain Line	021	TEH-130	Downcomer-Heater K	305
TEH-177	Drain Line	022	TEH-132	Downcomer-Heater L	306
TEH-172	Outlet of Pass #1 (Header)	023	TEH-137	Downcomer-Heater M	307
TEH-173	Pass #10	024	TEH-138	Downcomer-Heater M	308
TEH-174	Pass #11	<u>025</u>	TEH-139	Downcomer-Heater L	(Skip) 309
TEH-175	Pass #18	026			

TABLE A RS HEAT TRACE INSTRUMENTATION

T/C	DESCRIPTION	ACUREX CHANNEL	T/C	DESCRIPTION	ACUREX CHANNEL
TEH-218	Hot Tank Outlet	(B)100	TEH-207	Boost Pump Outlet - Heater A	122
TEH-216	FCV-221, Line X	(B)101	TEH-208	Boost Pump Outlet - Heater A	123
TEH-219	Hot Sump Outlet	(B)102	TEH-227	Cold Sump	*124
TEH-222	Hot Sump	(B)103	TEH-228	Cold Sump	*125
TEH-225	Cold Sump Outlet	104	TEH-220	Hot Sump	(B)*126
TEH-230	Cold Tank Inlet	105	TEH-221	Hot Sump	(B)*127
TEH-201	Boost Sump Drain - Heater D	106	TEH-211	Riser - Storage End - Heater H	128
TEH-202	Cold Pump Outlet - Heater C	107	TEH-241	FCV-151, Heater H	(A)129
TEH-265	Cold Sump Outlet	108	TEH-212	Downcomer - Storage - Heater K	130
TEH-229	Cold Sump Inlet	109	TEH-240	FCV-161, Heaters A-Y, K	131
TEH-233	Cold Tank #1, CT-1 thru 7	*110	TEH-213	Hot Tank #1	*134
TEH-234	Cold Tank #2, CT--1 thru 7	*111	TEH-214	Hot Tank #2	*135
TEH-235	Cold Tank #3, CT-1 thru 7	*112	TEH-215	Hot Tank #3	*136
TEH-231	FCV-201	113	TEH-217	Cold/Hot Tank Bypass-Heater AA	(A,B)137
TEH-232	Cold Tank Outlet	114	TEH-223	Propane Heater	(A)138
TEH-205	Boost Sump - Heater W	115	TEH-224	Propane Heater	(A)139
TEH-206	Boost Sump - Heater W	116	TEH-236	Cold/Hot Tank Bypass, Heater AA	(A,B)140
TEH-203	Boost Pump Bypass - Heater E	117	TEH-238	FCV-242	141
TEH-204	Boost Pump Outlet - Heater B	118	TEH-239	Propane Heater Outlet	(A)142
TEH-209	Cold Tank Inlet - Heater F	(B)119			
TEH-210	Cold Tank Bypass - Heater G	120	* <u>Record for TSS Step 2, stored salt temp's</u>		
TEH-237	FCV-162, Heater F	(B)121	(A) Normally not operating during system operation		
			(B) Not required for Propane Heater operation		

TABLE B TSS HEAT TRACE INSTRUMENTATION

T/C	DESCRIPTION	ACUREX CHANNEL	
TEH-305, 306	Hot Salt Inlet Lines	200, 201	
TEH-307, 308	Salt Piping Between SH and EV	202, 203	
TEH-309 thru 311	Cold Salt Inlet Lines	204 thru 206	
TEH-312 thru 314	EV Salt Outlet	207 thru 209	
TEH-315 thru 317	Salt Drain Lines	<u>210 thru 212</u>	
TEH-318, 319	SH and EV Outlet Overpressure	**213, 214	
TEH-320, 321	Superheater	215, 216	Open HV-487 (To trap T-482
TEH-322, 323	Evaporator	<u>217, 218</u>	-- to allow these to heat up, or HV-485 & HV-48
6005 thru 6009	Misc. Salt Lines (info.)	230 thru 234	233 (Skip)
6011 thru 6016	Superheater (info.)	##236 thru 241	234 (O.R.)
----	FCV-351 Body, Bonnet	<u>242, /243</u>	
6020 thru 6025	Evaporator (info.)	##245 thru 250	
6026 thru 6029	Hot Salt Inlet (info.)	251 thru 254	
6030, 6031	FCV-341 Body, Bonnet	<u>255, /256</u>	
6032, 6033	FCV-301 Body, Bonnet	257, 258	
6034, 6035	FCV-321 Body, Bonnet	259, 260	
6036, 6037	FCV-381 Body, Bonnet	261, 262	
6038, 6039	FCV-382 Body, Bonnet	263, 264	
6040 thru 6042	Salt Drain Lines (info.)	##265 thru 267	
6043	SH Drain (info.)	<u>**268</u>	
6044 thru 6053	Misc. Lines (info.)	269 thru 278	275 (Skip) 277 (O.R.)

\*\*These will normally be below salt freezing temperature (no problem).

##These may be below 480°F - But they should be above 400°F prior to salt flow.

TABLE C SGS HEAT TRACE INSTRUMENTATION

TABLE D GROUP ALARM LIST

28	<u>GAL</u>	GENERAL ALARMS						
29		LT-201	TE-180	TE-383	TE-508	LS-541	LV-281	AZT-581
		LT-221	TE-181	TE-387	TE-509	PS-281	LV-481	
		LT-281	TE-184	TE-388	TE-581	PS-485	N90.P5	
		LT-291	TE-211	TE-481		TS-501	N90.ALM	
		LT-311	TE-231	TE-484		TS-502		
		LT-471	TE-281	TE-486				
		LT-511	TE-286					
30	<u>RAL</u>	RECEIVER OPERATIONAL ALARMS						
		FT-101	LT-151	TE-101	PT-180	RMINT		
			LT-161	TE-102	PT-181	RMAXT		
				TE-161				
31	<u>SAL</u>	STEAM GENERATOR OPERATIONAL ALARMS						
		TE-301	TE-421	PT-321	PT-431			
		TE-331	TE-483	PT-382	PT-432			
		TE-332		PT-383	PT-483			
		TE-382		PT-384				
		TE-384		PT-386				
		TE-386						
33	<u>PAL</u>	ELECT. POWER OPERATIONAL ALARMS						
		ET-581	TT-501	TE-505	TT-521	PT-501	PT-531	
		ST-581	TT-502	TE-506	TT-583	PT-502	PT-581	
		ZSH-AEP	TE-503	TT-507			PT-583	

FIGURE 6.1 MSEE REMOTE OPERATED VALVE ALIGNMENT

10/5/84

VALVE	FUNCTION	PRETEST			OPERATION		POST TEST		
		BASIC FULL SYSTEM	MODIFICATION TO OPERATE 1. W/O RECVR 2. W/O OR W/O PROPANE HTR	MODIFICATION TO OPERATE 1. RECVR ONLY 2. PROPANE HTR ONLY	BASIC FULL SYSTEM	MODIFICATION TO OPERATE 1. W/O RECVR 2. W/PROPANE HTR			
FCV-101	RECVR FLOW CTRL	○ MAN			⊕ CASE 38 SALT SP 1000°F	○ MAN	○ MAN		
FCV-102	RECVR FLOW CTRL	○ MAN			⊕ CASE 38 SALT SP 1000°F	○ MAN	○ MAN		
FCV-151	CST LEVEL CTRL	● MAN	● L MAN	● L MAN (w/ HTR)	⊕ CASE LT-181 SP 87°F	● L MAN	○ MAN		
FCV-161	HST LEVEL CTRL	● MAN	● L MAN	● L MAN (w/ HTR)	⊕ AUTO SP 80°	● L MAN	○ MAN		
FCV-162	HST LEVEL CTRL	● MAN	○ MAN	○ MAN (w/ HTR)	● AUTO SP 80°	○ MAN	○ MAN		
FCV-180-189	RECVR DRAIN	○			●		●		
FCV-190-198	RECVR PURGE	○			●		●		
FCV-199	RECVR DRAIN & FILL	○			●		○		
FCV-201	COLD SUMP LEVEL CTRL	● AUTO SP 23°			⊕ AUTO SP 23°		● MAN		
FCV-211	COLD SUMP ISOLATE	● L			○		● L		
FCV-221	HOT SUMP LEVEL CTRL	● AUTO SP 80°			⊕ AUTO SP 80°		● MAN		
FCV-231	HOT SUMP ISOLATE	● L			○		● L		
FCV-241	PROPANE HTR FLOW CTRL	● L			● L	○ L MAN	●		
FCV-242	PROPANE HTR ISOLATE	● L	● (w/ HTR)	● (w/ HTR)	● L	○	●		
FCV-301	EVAP SALT TEMP CTRL	● MAN ON		● L MAN ON	⊕ MAN OFF NO CASE		● MAN ON		
FCV-321	SGS SALT FLOW CTRL	○ MAN ON			⊕ MAN OFF NO CASE		○ MAN ON		
FCV-331	STEAM TEMP CTRL	○ 10% MAN ON			⊕ MAN OFF NO CASE		○ 10% MAN ON		
FCV-341	SGS COLD SALT FILL CTRL	● MAN ON		● L MAN ON	● MAN ON		● MAN ON		
FCV-351	SGS HOT SALT FILL CTRL	● MAN ON			○ MAN ON		● MAN ON		
FCV-381	EVAP SALT DRAIN	○ MAN ON			○ MAN ON		● MAN ON		
FCV-382	SUPHTR SALT DRAIN	○			○		●		
FCV-383	START-UP HTR BYPASS	● MAN ON			○ MAN ON		● MAN ON		
FCV-384	START-UP HTR ISOLATE	○ MAN ON			● MAN ON		○ MAN ON		
FCV-401	FWP PRESSURE CTRL	● AUTO SP 1150			⊕ AUTO SP 1150		● AUTO SP 1150		
FCV-411	FEEDWTR FLOW CTRL	● MAN ON			⊕ MAN OFF NO CASE		● MAN ON		
FCV-421	FWM TEMP CTRL	○ AUTO SP 820°F			⊕ AUTO SP 820°F		○ AUTO SP 820°F		
FCV-431	DA & L STEAM PRESS CTRL	● CASE PT-431 SP 1080			⊕ CASE PT-431 SP 83.6		● CASE PT-431 SP 1080		
FCV-432	DA PRESSURE CTRL	○ AUTO SP 233			⊕ AUTO SP 233		○ AUTO SP 233		
FCV-471	DA LEVEL CTRL	● AUTO SP 0"			⊕ AUTO SP 18"		● AUTO SP 0"		
FCV-483	DA VENT NO. 1	○ LOCAL			○ LOCAL		● LOCAL		
FCV-484	DA VENT NO. 2	● LOCAL			● LOCAL		● LOCAL		
FCV-485	DEMIN WATER TANK FILL	● LOCAL			● LOCAL		● LOCAL		
FCV-491	START-UP STEAM CTRL	● AUTO SP 900			○ AUTO SP 900		● AUTO SP 900		
FCV-501	TURBINE STOP	●			○		●		
FCV-511	HOTWELL OUTFLOW	●			⊕		●		
FCV-512	HOTWELL MAKE-UP	●			⊕		●		
FCV-521	OIL COOLANT FLOW CTRL	● AUTO SP 150° F			⊕ AUTO SP 150° F		● MAN		
FCV-541	CHST MAKE-UP	● LOCAL CTRL			⊕ LOCAL CTRL		● LOCAL CTRL		
FCV-551	CONDENSATE RECIRC	●			●		●		
FCV-561	TURBINE TRIP	● ET OFF			● ET OFF		● ET OFF		
TVM	TURBINE THROTTLE	●			⊕		●		

● L LOCKED  
 ○ OPEN  
 ⊕ CONTROLLING  
 ○ CLOSED

COP #2 CONTROL ROOM POST-TEST CHECKLIST

Test Date  
10/17/84

This Console operating procedure will be utilized to secure the process controls following all tests. This checklist shall be completed by the Control Room process console operator.

<u>STEP</u>	<u>DESCRIPTION</u>	<u>VERIFICATION</u>
<u>I. HELIOSTAT SUBSYSTEM</u>		
	1. Verify system returned to a safe condition; (Heliostats, salt, steam, water)	_____
<u>II. RS RECEIVER SUBSYSTEM</u>		
	1. Verify the following valve alignment:	_____
01	FCV-101 Man/Open	
	FCV-102 Man/Open	
	FCV-180 thru 189 Off/Closed (ZSL's on)	08
	FCV-190 thru 198 Off/Closed (ZSL's on)	09
02	2. Verify the receiver cavity door is fully closed (ZSLDR on).	_____
	3. Verify RS secured from technician - post test checklist completed (ROP #4).	_____
<u>III. TSS THERMAL STORAGE SUBSYSTEM</u>		
	1. Verify the following valve alignment in MAN:	
02	FCV-151 Open 04 FCV-211 Closed/Locked	
	FCV-161 Open 04 FCV-221 Closed	
	FCV-162 Open 04 FCV-231 Closed/Locked	
	FCV-199 Open 05 FCV-241 Closed	
04	FCV-201 Closed 05 FCV-242 Closed	
	CSP.EN Off, BP.EN Off, HSP.EN Off	_____
	2. Record the following salt levels & temp's:	
	LT-201 Cold sump _____ in. @ _____ °F (Acurex Chan 124,125)	
03	LT-281 Cold tank _____ in. @ _____ °F (Acurex Chan 110-112)	
	LT-221 Hot sump _____ in. @ _____ °F (Acurex Chan 126,127)	
	LT-291 Hot tank _____ in. @ _____ °F (Acurex Chan 134-136)	
	3. Verify TSS secured from technician - post test checklist completed (TOP #4).	_____



COP #2 CONTROL ROOM POST-TEST CHECKLIST

<u>STEP</u>	<u>DESCRIPTION</u>	<u>VERIFICATION</u>
<u>IV. SGS STEAM GENERATION SUBSYSTEM</u>		
	1. Verify the following valve alignment:	_____
13	*FCV-301 Closed      MAN.384 On *FCV-321 Open        FCV.384 On (open) *FCV-331 10% Open    MAN.38182 On *FCV-341 Closed      FCV.38182 Off (closed) *FCV-351 Closed	_____
	*Emcon commands - MAN signals on with SP in Auto to the positions noted.	
	2. Verify SGS secured from technician - post test checklist completed (SOP #4).	_____
<u>V. HRFS HEAT REJECTION AND FEEDWATER SUBSYSTEM</u>		
	1. Verify the following device alignment:	
	EH1                    --                    Off	
	EH2                    --                    Off	
	GSTAT                --                    Off	
18	FCV-431 Closed      Casc	
	FCV-432 Open        Auto SP 233	
	FCV-471 Closed      Auto SP 0%	
	FY-472 Closed        Auto SP 0%	
	FCV-411 Closed      MAN.411 On/SP.411 Auto 0%	
	FCV-491 Closed      Auto Closed	
	FCV-501 Closed      Off/ZSL-501 On	
19	Pump EN Signals      Off	_____
20		_____
	2. Verify HRFS secured from technician - post test checklist completed (HOP #4).	_____
<u>VI. EPGS ELECTRIC POWER GENERATION SUBSYSTEM</u>		
21	1. Verify TCPMS is off.	_____
	2. If used, reset bkr control switch to green flag, remove the RGP Sync switch handle and return it to the MSEE key box. Set Run Volt and Speed controls down.	_____
	3. Verify EPGS secured from technician - post test checklist completed (POP #4).	_____
<u>VII. MCS MASTER CONTROL SUBSYSTEM</u>		
	1. Disable general alarms by turning GAL off.	_____
	2. Safe the Emcon and Net. 90 control consoles to eliminate any inadvertant control inputs. (Lock-up)	_____

<u>STEP</u>	<u>DESCRIPTION</u>	<u>VERIFICATION</u>
1.	EMCON System Shutdown	
	a) Terminate MSSND execution	_____
	b) Execute "SHUT UP" command file	
	1) No device modifications	_____
	c) Spin down disk drives	_____
	d) Turn off power to equipment	_____
2.	Acurex System Shutdown	
	a) Terminate host operation via key switch control	_____
	b) Turn off power to equipment	_____
3.	Data System Shutdown	
	a) Terminate programs	_____
	b) Spin down disc drive	_____
	c) Turn off power to equipment	_____
4.	Net-90	

This General Receiver Operating Procedure will be utilized as the manual, Emergency Shutdown Procedure during System Testing. It will cover two specific conditions: 1) Electrical or Power Loss, and 2) Process Control Module Failure (PCM 1 and PCM 3). Realize these are only two of many possible emergency conditions; therefore it is mandatory to be familiar with all shut down procedures. All actions are to be coordinated with the control room. The two failure modes identified above will, when encountered, require timely response and are incorporated into this procedure. Other failure modes, although quite possibly emergency in nature, will not be part of this procedure and, therefore, it is imperative the Test Conductor is intimately familiar with the total system.

#### NOTE

In the event of a facility commercial power failure or fire alarm in 9980 or 9981, verify that the heliostats are moving off the target to the stowed position. Test conductor will determine if control room is to be evacuated. If possible, all subsystems should be failsafe before evacuating.

If Acurex does not come back online, have heat trace put into local control for receiver heat tracing.

All control valves should be checked for temperatures above 430°F.

#### PART 1 - COMMERCIAL POWER LOSS

In the event of a commercial power loss, the individual subsystems will be failsafed. Any actions required will be performed by the field technician.

<u>STEP</u>	<u>DESCRIPTION</u>	<u>VERIFICATION</u>
I.	Receiver	
1.	In the event of a facility commercial power failure, the following events should automatically occur:	
	a) The EPS will initiate heliostat defocus.	_____
	b) The following valves will fail OPEN: FCV-101, 102, 161, 199.	_____
	c) The following valves will fail CLOSE: FCV-151, 162, 180 through 198, 231.	_____
	d) The salt pump motors will stop.	_____

COP #1A EMERGENCY SHUTDOWN

<u>STEP</u>	<u>DESCRIPTION</u>	<u>VERIFICATION</u>
-------------	--------------------	---------------------

	e) Back up battery power will come up for the Receiver Assembly (only for manual control) and the Main Grid Circuit Breaker.	_____
--	------------------------------------------------------------------------------------------------------------------------------	-------

2. The receiver tech will do the following:

a) Verify FCV-101/102 are open  
FCV-180 thru 198 are closed

b) Allow approximately 3 minutes for the cold surge tank to deplete to zero, then wait 30 seconds prior to continuing.

c) Manually open FCV 180-189, and FCV 190-198 from local control panel in tower. Note time \_\_\_\_\_.

d) Put heat trace in local and on.

NOTE

If receiver valve temperatures have dropped below 430°F, lock open purge and drain valves before continuing.

II. SGS/TSS

1) The following events should happen automatically:

a) All pumps will stop.

b) All control signals from Emcon and Net 90 will be lost.

c) Air compressors will stop.

d) The following valves will fail OPEN:  
FCV-301, 321, 331, 351, 383, 384;

e) The following valves will fail CLOSED:  
FCV-201, 211, 221, 231, 241, 242, 341, 381, 382;

f) All trace heater circuits will de-energize.

2) The SGS/TSS tech will do the following:

WARNING

Hot sump may overflow

COP #1A EMERGENCY SHUTDOWN (MANUAL)

<u>STEP</u>	<u>DESCRIPTION</u>	<u>VERIFICATION</u>
a)	Manually lock closed FCV-211/FCV-231	Time: _____
b)	Verify valves on top of hot tank are in correct failsafe position.  FCV 161 OPEN FCV 162 CLOSED FCV 151 CLOSED FCV 199 OPEN FCV 242 CLOSED	_____
c)	Twenty minutes after shutdown the following valves should be opened:  FCV 151 FCV 162	_____
d)	Turn off backup pneumatic air supply	_____
	NOTE The following two steps should be done if SGS was operating.	
e)	Manually open FCV 341, 381, 382	TIME: _____
f)	Thirty minutes after opening FCV 341 manually close FCV 301, 341, 381, 382, and place handwheels back to neutral.	_____
g)	Perform SGS/TSS post-test shutdown.	_____

III. HRFS

1) The following events should happen automatically:

- a) All pumps will stop; \_\_\_\_\_
- b) All control signals from Emcon will be lost; \_\_\_\_\_
- c) Air compressor will stop; \_\_\_\_\_
- d) The following valves will fail OPEN: FCV-421; \_\_\_\_\_
- e) The following valves will fail closed:  
FCV-411, 431, 471, 491, 432 (fail to SWH Ex.) \_\_\_\_\_

2) Perform HRFS post-test shutdown; \_\_\_\_\_

<u>STEP</u>	<u>DESCRIPTION</u>	<u>VERIFICATION</u>
IV.	EPGS	
	1) Trip will occur automatically and fail safe;	_____
	2) Perform EPGS post-test shutdown.	_____

PART II. Process Control Module Failure (PCM)

All PCMs are on an Uninterruptible Power Supply (UPS), so PCMs should stay on line. There is always a possibility of a failure, and the field technicians will be required to operate the controls from the back of the PCM or at the digital control panel. The control room will direct all operations.

I. PCM 1 Failure

NOTE

EPS will do the following:

- a) Defocus heliostats
- b) Close FCV 151.

1) RS technician will do the following:

- a) Verify FCV 151 is indicating closed at PCM 1 \_\_\_\_\_
- b) Place receiver control in local \_\_\_\_\_
- c) Close cavity door from receiver control panel \_\_\_\_\_
- d) Wait 3 minutes prior to continuing \_\_\_\_\_
- e) Verify FCV 101/102 are indicating open at PCM 1 \_\_\_\_\_
- f) Open drain valves FCV 180-189 from receiver control panel \_\_\_\_\_
- g) Open purge valves FCV 190-198 in 10 second intervals, from receiver control panel \_\_\_\_\_
- h) Perform RS post-test shutdown when required \_\_\_\_\_

2) Control room operator will do the following:

- a) Turn RS Man on \_\_\_\_\_

NOTE

Monitor Lt 201. If it goes above 30", have RS technician close FCV 151.

COP #1A EMERGENCY SHUTDOWN (MANUAL)

<u>STEP</u>	<u>DESCRIPTION</u>	<u>VERIFICATION</u>
b)	If hot salt (greater than 750) was being produced, deactivate FCV 161 and open.  Go to step d	TIME: _____
c)	If RS is in cold flow deactivate FCV 162 and open.	TIME: _____
d)	Turn off boost pump	_____
e)	Wait 3 minutes and open FCV 199	TIME: _____
f)	Shut down SGS if operating. Use SOP 3.	_____
g)	If RS is operating without SGS on line do the following:	
	1) Close FCV 211 and have it locked closed	_____
	2) Deactivate FCV 201 and close	_____
	3) Turn off cold pump	_____
	4) 30 minutes after step e, have RS technician close FCV 180-198	_____
	5) Have RS technician open FCV 151	_____
	6) Open FCV 162	_____
h)	If SGS was on line, FCV 151 and FCV 162 will have to be opened after pumps are shut off.	_____
i)	RS and TSS are shut down, have technician go through post-test shutdown.	_____
j)	Return all controls to REMOTE.	_____

II. PCM 3 Failure

EPS will do the following:

- a) Defocus heliostats
- b) After a time delay close FCV 211 and FCV 231

COP #1A EMERGENCY SHUTDOWN (MANUAL)

<u>STEP</u>	<u>DESCRIPTION</u>	<u>VERIFICATION</u>
	c) Stop salt pumps	
	d) Close FCV 501	
	N 90 will close FCV 341, 301, and 351. FCV 199 will fail open.	
1)	Control room operator will do the following:	
	a) Close FCV 101/102	
	b) Verify/close FCV 151	
	c) Have TSS/SGS technician take local control of FCV 162 and open, or FCV 161 and open. FCV 161 is opened when in hot salt flow.	_____
	d) Have TSS/SGS technician close 201/221	_____
	e) Close cavity door	TIME: _____
	f) Wait 3 minutes before continuing.	_____
	g) Open FCV 180-189	_____
	h) Open FCV 190-198	_____
	i) Open FCV 101/102	_____
2)	TSS/SGS Technician will be required to do the following:	
	NOTE	
	All operations will have to be coordinated with the control room.	
	a) Lock close FCV 211 and FCV 231	_____
	b) Take local control of FCV 161 or FCV 162 and open.	_____
	c) Take local control of FCV 201 and FCV 221 and close.	_____
	d) 30 minutes take local control of FCV 161 or FCV 162 and close.	_____
	e) Perform TSS/SGS post-test shutdown.	_____



## Emergency Situations

Besides commercial power failure and PCM failures, there are also other emergency situations which might occur. The following will cover possible emergency situations and the action required.

### 1) Cold Pump/Boost Pump Failure

RCVR - If possible refill cold sump and start CSP and BP.

SGS - If possible refill cold sump and restart CSP and BP if needed.

Propane Heater/Failure - Immediately shut FCV-241 and advise TSS tech to lower stack temp. to 600.

Refill cold sump and start CSP. If the pump will not start, you must drain the propane heater. If SGS is on-line drain most of its salt back to the hot sump.

### 2) High Sump Levels:

EMCON has an interlock to close either FCV-211 or 231 when either LT-201 or LT-221 read high. TSS tech. will need to lock these valves closed if a problem exists.

### 3) High Hot Surge Tank High (LT 161 70");

There are two interlocks for this situation, EPS or EMCON.

EMCON Interlock:

- 1) Closes FCV-101/102 (EL01B)
- 2) Opens FCV-161 (EL03A)
- 3) Closes FCV-199 (EL03A)

EPS

- 1) Close FCV-101/102
- 2) Opens FCV-161

System must be drained below 70" in hot surge tank (LT-161) before valves can be operated. If FCV 101/102 close with TE 102-750°F EPS will trip (TR 183).

### 4) Plug in Boost Pump Discharge

RCVR - If operating/filling RCVR stop operation and drain.  
- If possible, run CSP and BP and try to melt through the blockage.

### 5) Salt Downcomer Line Blockage

RCVR - This usually occurs when filling the RCVR. If cold surge tank (LT-151) shows level in less than two minutes when starting the fill sequence, a manual operation will be needed in filling/draining RCVR.

6) Boost Sump High Level

RCVR - EPS will scram heliostats and close FCV-151 and turn off BP

The RCVR must be drained..

SGS - If SGS is on-line with the RCVR leave CSP on and drain RCVR first ,  
then SGS, can be drained.

7) Feedwater Control Problems

- If drum level is not holding, or taking swings, it will sometimes be  
necessary to take manual control of FCV-411 from the Bailey and control  
drum level manually.

8) Spray Water Pump Problem

If pump loses mechanical seal, the system will need to be shut down. If SGS  
is on-line with HRFS, bring SGS down first and then bring HRFS down.

9) SGS Emergency Shutdown Due To Loss Of Salt Flow

If for any reason HSP or CSP turn off and can't be restarted, SGS should be  
bottled up and drained when TE-382 is less than 750°F.

This Receiver operating procedure will be utilized to verify RS integrity prior to all tests that use the Receiver. This checklist shall be completed by the RS technician.

<u>STEP</u>	<u>DESCRIPTION</u>	<u>VERIFICATION</u>
1.	Turn on the Tower Air Compressor in continuous duty. Verify pneumatic air is available at 80 psig min. Note it may already be on for HRFS or Facility.	_____
2.	Verify air is being supplied to the Cold Surge Tank and backup air supply for the Drain/Purge Valves (separate manifolds) as follows: a. Open valves on supply bottles. b. Verify supply bottles at 300 psig minimum. c. Adjust the backup air supply regulator to 65 psig	_____
3.	Verify the EPS and 2 each control panel power supplies are ON with each set to 24 volts.	_____
4.	Verify the receiver uninterruptable power supply (UPS) is ready and operational (battery gage greater than 90V).	_____
5.	Set up remote camera.	_____
6.	Verify/adjust the pneumatic activated valve air set on the Drain and Purge valves (FCV 180 - 198) to 30 psig outlet pressure (should be done with valves open).	_____

CAUTION

Verify valve temp's with control room prior to cycling.

NOTE

Heat tracing Auto control may be overridden from module control room and locally controlled if necessary.

7. Align/verify valve positions as specified - coordinate with EMCON operator; verify pneumatic pressure to the valves (FCVs)

FCV 101	Salt Flow Control	Open/N
FCV 102	Salt Flow Control	Open/N

8. Visually check the Receiver Cavity Door, Cavity Walls, and the door supports for evidence of scorching. Coordinate RS cavity door operation with Emcon operator.

ROP #1 RECEIVER PRETEST CHECKLIST

<u>STEP</u>	<u>DESCRIPTION</u>	<u>VERIFICATION</u>
9.	Align/verify valve positions as specified - coordinate with Emcon operator:  FCV 180-189    Drain Valves            Open/N FCV 190-198    Purge Valves            Open/N	_____
10.	Using a probe, verify the Hot Surge Tank Vent is free of frozen salt (not blocked).	_____
11.	Check Flux Gage Coolant Pump, and radiator for leaks. Verify level in radiator is within 2" of top.	_____
12.	Verify coolant flow through Flux Gages - indication on flowmeter.	_____
13.	Check for visual evidence of blown fuses, burned relays or burned electrical components in the power junction box and generally through out the receiver subsystem.	_____
14.	Inspect the salt system for evidence of leaks and insulation damage. This is a general inspection for any condition that appears abnormal. If a problem is detected (i.e. salt leak, etc.), a more thorough inspection will be required.  o RS tower piping o Surge Tanks (2 ea) o Valves (21 ea) o Receiver Assembly (Panel)	_____
15.	Advise the control room that the RS pre-test checklist has been completed.	_____

THE RECEIVER SUBSYSTEM IS READY FOR STARTUP

This Receiver operating procedure shall be performed by the Emcon operator. Periodically advise the RS technician of status.

<u>STEP</u>	<u>DESCRIPTION</u>	<u>VERIFICATION</u>
1.	Verify completion of the following checklists:  <ul style="list-style-type: none"> <li>o CS Pretest Activity (Heliostats to Line Bottom)</li> <li>o COP #1 Control Room Pretest Checklist</li> <li>o ROP #1 RS Pretest Checklist</li> <li>o TOP #1 TSS Pretest Checklist</li> </ul>	_____
<u>WARNING</u>		
<p>Only operating personnel are allowed in the salt storage and receiver areas while system is operating. Access is to be controlled by the test conductor. Protective clothing must be worn by personnel working in these areas during operation. All other personnel are to keep clear of these areas.</p>		
2.	Advise the Heliostat operator to Bring the Heliostat Field up to Far Standby.	_____
02 3.	Open the Receiver Cavity Door (DR.OPN). Verify visually and by micro indications (ZSHDR on).	_____
26 4.	Reset EPS Racks 1 and 3 (turn EPS1.RST and EPS3.RST on then off). Verify Emcon SCRAM disable signal is On.	_____
5.	Advise the Heliostat operator to Direct Warmup A Heliostat Group at the receiver. (Use CRTF's OP-78-03 for specific steps.)	_____

NOTE

Graphic 990 Receiver panel temperatures (TE-131 thru TE-148) must be greater than 450°F prior to opening FCV 151 (step 19) during manual startup or starting RS.Fill automatic sequence (step 11) during automatic startup.

CAUTION

- o Receiver maximum temperature: 1050°F
- If any receiver temperatures remain below 450°F, heliostats may need to be added to increase the temperature of that portion of the panel. Conversely, if any temperatures start approaching 1000°F, heliostats will have to be removed to limit the flux to that portion of the panel.

ROP #2 RECEIVER STARTUP

<u>STEP</u>	<u>DESCRIPTION</u>	<u>VERIFICATION</u>
-------------	--------------------	---------------------

	6. Advise the salt storage tech. to unlock FCV-211.	_____
--	-----------------------------------------------------	-------

04	7. When unlocked, open FCV 211, verify micros. (If Cold Sump level LT-201 is equal to or greater than 50 inches, this step should be delayed until just prior to starting the CSP to avoid leakage and possible sump overflow.	_____
----	--------------------------------------------------------------------------------------------------------------------------------------------------------------------------------------------------------------------------------	-------

	8. Enable cold sump level control and fill sump as follows to prime CSP for starting and provide an adequate salt reservoir for fill operations:	
--	--------------------------------------------------------------------------------------------------------------------------------------------------	--

	a. Activate FCV-201 with a SP of 48"	
04	b. Verify sump level is 50" min. (60" max.)	
	c. Reset FCV-201 SP to 45"	_____

	9. Reverify salt path temperatures are acceptable:	
--	----------------------------------------------------	--

GR 990	° Receiver Panel	TE-131 thru 148	
10	° Receiver Pass Outlet	TE-101 thru 120	
07	° Receiver Header	TE-182 thru 198	
	° Acurex RS	(COP #1 Table A)	
	° Acurex TSS	(COP #1 Table B)	_____

If FCV-161/FCV-162 PV does not read the same value as LT-161, verify that CA161 is on.

NOTE

11	The auto fill sequence starts here. Start-up can be accomplished using the auto start sequence (RF) or manually from the Emcon console.	
----	-----------------------------------------------------------------------------------------------------------------------------------------	--

GR 992	For auto fill verify TSO OFF	<u>MAN</u> <u>AUTO</u>
	For auto fill refer to page 6 for receiver auto fill sequence checklist.	

	10. Activate the FCV 161 Hot Surge Tank Level Control with a set point of 75 inches.	_____
--	--------------------------------------------------------------------------------------	-------

	11. Activate the FCV 162 Hot Surge Tank Level Control with a set point of 56 inches. In manual fill TSO must be enabled to permit a SP change different than 20".	_____
--	-------------------------------------------------------------------------------------------------------------------------------------------------------------------	-------

NOTE

TSO is available to override FCV-161/162's transfer control.

ROP #2 RECEIVER STARTUP

---

<u>STEP</u>	<u>DESCRIPTION</u>	<u>VERIFICATION</u>
12.	Start the Cold Salt Pump (CSP).	_____
13.	Start the Boost Pump (BP).	_____
14.	Enable pump pressure alarm PT180.	_____
15.	When the PT-180 Pump Outlet pressure is greater than 310 psi, incrementally open FCV 151 to 50% in 10% steps.	_____

NOTE

Monitor the Receiver sequential fill.  
Pipes fill (TE-161), CST level rises (LT-151),  
Flow starts (FT-101), HST level rises (LT-161).

16.	Close FCV-199 (FCV-199 on) when HST level LT-161 reaches 10" (after 50" CST level). Verify micro ZSL199 on.	_____
17.	When the LT-161 Hot Surge Tank level approaches 55 inches, Verify FCV-162 is in auto and maintaining 56 inches.	_____

NOTE

If HST level reaches 70", Emcon will close FCV-101,102, 151,199. This may be overridden on an individual PCM basis by OVR1, OVR2, or OVR3.

18.	Close drain valves FCV-180 thru 189 (off). Verify closure.	_____									
19.	Sequentially close the following Purge Valves at 10 sec. intervals (off) to establish serpentine flow. Verify closure.	_____									
	<table border="0"> <tr> <td>FCV-190</td> <td>FCV-193</td> <td>FCV-196</td> </tr> <tr> <td>FCV-191</td> <td>FCV-194</td> <td>FCV-197</td> </tr> <tr> <td>FCV-192</td> <td>FCV-195</td> <td>FCV-198</td> </tr> </table>	FCV-190	FCV-193	FCV-196	FCV-191	FCV-194	FCV-197	FCV-192	FCV-195	FCV-198	_____
FCV-190	FCV-193	FCV-196									
FCV-191	FCV-194	FCV-197									
FCV-192	FCV-195	FCV-198									

20.	Reset the FCV-162 Hot Surge Tank Level set point to 20".	_____
21.	Reset the FCV-201 Cold Sump Level set point to 23".	_____
22.	Establish Receiver manual salt flow control: <ul style="list-style-type: none"> <li>a. Take RCA off scan.</li> <li>b. Activate FCV-101/102 CASC control (from FD-101)</li> <li>c. Verify FD-101 is in auto and adjust SP to 30 Klb/hr. Verify flow below 35Klb/hr.</li> </ul>	_____
23.	Activate the FCV 151 casc. Cold Surge Tank Level Control, then update auto. LT 151 level control with a set point of 87 inches.	_____

ROP #2 RECEIVER STARTUP

---

<u>STEP</u>	<u>DESCRIPTION</u>	<u>VERIFICATION</u>
24.	Activate the Receiver Temperature Control by putting RCA on scan. (Temperature set point SP.SALT will automatically come up at 750°F. This will maintain a low salt flow rate through the receiver with only the warm-up Heliostats on target. FD-101 is automatically controlled from RCA.)	_____
30 25.	Enable Receiver operational alarms by turning RAL on.	_____
11 26.	Verify/Turn off RF if it was used. (Turns itself off when auto fill is complete).	_____

THIS IS THE END OF THE AUTOMATIC SEQUENCE. THE R.S. IS NOW OPERATIONAL (WARM STANDBY) AWAITING START OF SOLAR CHARGING ACTIVITY.

CAUTION

27 If FCV-101/FCV-102 are not controlling, verify that these blocks are ON: RD101, ALGPID, CA101C.

NOTE

Receiver minimum flow rate is auto limited to 30 klb/hr.

27.	To maintain the Warm Standby condition (cold flow) for an extended period of time:	
—	a. Deactivate the Receiver Control Algorithm by taking RCA off scan.	
01	b. Reset the FD-101 Salt Flow Control set point to 30 klb/hr or to desired flow rate.	
—	c. Remove the warm-up heliostats from the receiver.	
<u>02</u>	d. Close the receiver cavity door and verify.	Extended Warm Stdby

28.	Prepare for solar charging by verifying:	
	a. Receiver cavity door is open.	
	b. Warm-up Heliostats are on Receiver.	
	c. RCA Receiver temperature control algorithm is activated - scan on.	
	d. SP.SALT setpoint is initially set to 750°F.	_____

29.	Conduct solar charging by advising the Heliostat operator to direct incremental Heliostat groups onto the Receiver per operating condition requirements. (Eighth of the field increments are standard). Adjust/Step-up SP.SALT accordingly (1050°F max.) and be alert for cloud and process transients.	Solar Charging
-----	---------------------------------------------------------------------------------------------------------------------------------------------------------------------------------------------------------------------------------------------------------------------------------------------------------	----------------



<u>STEP</u>	<u>DESCRIPTION</u>	<u>VERIFICATION</u>
-------------	--------------------	---------------------

NOTE

To protect the receiver from cloud transients during charging conditions when temps and flows are above 925°F and 35Klb/hr, SP.SALT will automatically reset itself down to 925°F if flow drops to 35Klb/hr. (RCAR)

30. When individual heat trace thermocouple temperatures exceed 750°F, verify the following Acurex channels indicate CLSD (circuit automatically turned off):

<u>Channel</u>	<u>Area</u>
*063	Upper and Lower Headers
*064	Secondary Headers
065	Header East End
066	Receiver outlet
069	Hot Surge Tank
451	Downcomer and Hot Tank inlet

\*The switch on the Module Control Room local control panel must be in REMOTE to allow Acurex automatic control to turn these off.

---

THE RS IS NOW ON LINE IN SOLAR CHARGING CONFIGURATION.

NOTE

During RS Solar operations, intermittantly monitor these parameters:

- |                             |                                           |
|-----------------------------|-------------------------------------------|
| -- Solar Insolation         | - (CF) Control Room Weather Monitor Panel |
| above 600 W/M <sup>2</sup>  | - (TSS) Emcon 'SUN'                       |
| -- Cavity Door Temperatures | - Acurex channels 45,46, & 47             |
| -- Approaching Clouds       | - Step Outside                            |

ROP #2 RECEIVER STARTUP

---

RECEIVER AUTO FILL SEQUENCE CHECKLIST

<u>Step</u>	<u>Description</u>	<u>Verification</u>
1.	Cold Salt Pump ON	_____
2.	Boost Pump ON	_____
3.	Boost Pump Discharge Pressure PT-180 to 310 PSI	_____
4.	FCV-151 OPEN 50%	_____
5.	TE-161 Responds to Salt	_____
6.	Salt in Cold Surge Tank, 2 Min. after step 4.	_____
7.	TE-101 Responds to Salt FT-101 Starts Indicating Flow	_____
8.	Salt in Hot Surge Tank (when cold surge tank level LT-151 reaches 40-50 inches).	_____
9.	FCV-199 CLOSED (when hot surge tank level LT-161 reaches 10"	_____
10.	Drain Valves CLOSED (when hot surge tank level LT-161 reaches 56"	_____
11.	Purge Valves Sequentially Close (EMCON Group 09)	_____
12.	Hot Surge Tank Level LT-161 Decrease to 20" With FCV-162 Controlling	_____
13.	Cold Sump Level Controlling at 23"	_____
14.	FCV-101/102 Controlling Receiver Salt Flow at 30 Klb/hr	_____
15.	FCV-151 100% OPEN Increasing Cold Surge Tank Level LT-151 to 80-85"	_____
16.	Return to Step 26 of Receiver Startup Procedure ROP #2	_____

This Receiver operating procedure shall be performed by the Emcon operator. Periodically advise the RS and TSS technicians of status.

STEP	DESCRIPTION	VERIFICATION
	1. Defocus the heliostats.	_____
01	2. Verify/Adjust SP.SALT to 750°F, FCV-201 SP to 23".	_____
02	3. When FT-101 drops to less than 30 Klb/hr, close the receiver cavity door and verify micros.	_____
01 02	4. Deactivate the Receiver Control Algorithm (by taking RCA off scan) and set the FD-101 set point to 60 Klb/hr. Wait 3 minutes minimum and continue when TE-161 is less than 700°F. Verify FCV-162 is open and maintaining level in HST.	_____
02	5. Deactivate FCV-161 control and close.	_____
	6. Check Acurex Ch 000-018, if below 480°F advise RS technician to turn heat trace to local 'ON' until acceptable. When individual heat trace thermocouple temperatures drop below 700°F, verify the following Acurex channels indicate OPEN (circuit automatically turns on):	
	*063 Upper and Lower Headers	
	*064 SecondaryHeaders	
	065 Header East End	
	066 Receiver Outlet	
	069 Hot Surge Tank Inlet	
	*The switch on the Module Control Room local control panel must be in REMOTE to allow Acurex automatic control to turn these on.	_____
	THE RS IS NOW IN WARM STANDBY. SALT FLOW MAY BE VARIED TO PROVIDE DESIRED TEMPERATURE/FLOW THROUGH THE RECEIVER.	
	<u>NOTE</u>	
11 GR 992	The RD Auto Drain Sequence starts here. Shutdown can be accomplished using the Auto sequence or manually from the EMCON console. Note Auto seq. steps are not performed in the exact order that follows.	MAN AUTO
01	7. Set FD-101 setpoint to 30 Klb/hr. Wait for flowmeter FT-101 to stabilize at 30 Klb/hr + 3 Klb/hr, then cont.	_____

ROP #3 RECEIVER SHUTDOWN

---

<u>STEP</u>	<u>DESCRIPTION</u>	<u>VERIFICATION</u>									
8.	Open the following purge and drain valves (on). Verify open micros ZSH 180 thru 198 on.										
	<table border="0"> <thead> <tr> <th><u>Descriptor</u></th> <th><u>Tag</u></th> <th><u>Control</u></th> </tr> </thead> <tbody> <tr> <td>Drain Valves</td> <td>FCV-180 thru 189</td> <td>FCV 180T89</td> </tr> <tr> <td>Purge Valves</td> <td>FCV-190 thru 198</td> <td>FCV 190T98</td> </tr> </tbody> </table>	<u>Descriptor</u>	<u>Tag</u>	<u>Control</u>	Drain Valves	FCV-180 thru 189	FCV 180T89	Purge Valves	FCV-190 thru 198	FCV 190T98	
<u>Descriptor</u>	<u>Tag</u>	<u>Control</u>									
Drain Valves	FCV-180 thru 189	FCV 180T89									
Purge Valves	FCV-190 thru 198	FCV 190T98									
30 9.	Disable RAL by turning it off.										
10.	Deactivate FCV-101 & 102 auto control. Close FCV-101 & 102. Verify closed micros. Wait 30 seconds before continuing. (Note Auto sequence leaves these in Auto).										
11.	Change LT-151 set point to zero. Verify FCV-151 closed.										
12.	Deactivate FCV-151 auto control.										
13.	Verify FCV-162 closed (in Auto). <u>The RS is now bottled up and stagnant.</u>										

CAUTION

The next three steps initiate salt drain back to the Cold Salt Tank and must be accomplished following the sequence described. An early response could cause an overflow of the hot surge tank. A late response could cause damage to the receiver piping.

WARNING

Only operating personnel are allowed in the salt storage and receiver areas while system is draining. Access is to be controlled by the test conductor. All other personnel are to keep clear of these areas.

14.	To drain HST and downcomer, Deactivate FCV-162 auto control, ramp open FCV-162 to 100% in 20% increments 5 seconds apart, verify open micro, continue when LT-161 reaches 0" or stops decreasing.	
15.	Open FCV-199 to drain CST and riser, observe LT-151 at 15 inches, then wait 5 seconds.	
16.	Open FCV-101 & 102 5% to drain Receiver residual salt, Record time. (Ref. step 24).	

TIME

ROP #3 RECEIVER SHUTDOWN

---

<u>STEP</u>	<u>DESCRIPTION</u>	<u>VERIFICATION</u>
-------------	--------------------	---------------------

17.	Deleted.	
-----	----------	--

NOTE

If SGS is operating (ZSH.HSP ON), go to Step 24.

18.	Disable PT-180 pump pressure alarm.	_____
-----	-------------------------------------	-------

19.	Turn off boost pump.	_____
-----	----------------------	-------

20.	Turn off cold salt pump.	_____
-----	--------------------------	-------

21.	Change FCV-201 set point to zero, wait 15 seconds.	_____
-----	----------------------------------------------------	-------

22.	Put FCV-201 into manual.	_____
-----	--------------------------	-------

23.	Close FCV-211 and manually lock it closed.	_____
-----	--------------------------------------------	-------

24.	Open FCV-101 & 102 100%, approximately 2 minutes after completing Step 16.	_____
-----	----------------------------------------------------------------------------	-------

TIME

25.	Verify/Turn off RD (Turns itself off when Auto Drain is complete)	_____
-----	-------------------------------------------------------------------	-------

THIS IS THE END OF THE AUTOMATIC DRAIN SEQUENCE.  
THE RS IS AWAITING RESIDUAL SALT DRAINBACK.

02	26.	If the SGS is not in operation, 15 minutes after completing Step 24, open:	
		FCV-151	
		FCV-161 (only if hot tank has salt level)	_____

01	27.	If the SGS is not in operation, 20 minutes after completing Step 24, close the following valves:	
		FCV-180-189      FCV-194	
		FCV-190          FCV-195	
		FCV-191          FCV-196	
		FCV-192          FCV-197	
		FCV-193          FCV-198	_____

28.	Advise RS tech to turn trace heat back to remote, if turned on locally in step 6.	_____
-----	-----------------------------------------------------------------------------------	-------

29.	Advise the RS and TSS technicians to complete their post test checklists (ROP #4 & TOP #4). if no further RS or TSS operation planned.	
-----	----------------------------------------------------------------------------------------------------------------------------------------	--

THE RS IS NOW SHUTDOWN AND DRAINED.

ROP #4 RECEIVER POST TEST CHECKLIST

Test Date  
10/17/84

This Receiver operating procedure will be utilized to verify RS integrity following all tests that use the Receiver. This checklist shall be completed by the RS technician.

<u>STEP</u>	<u>DESCRIPTION</u>	<u>VERIFICATION</u>								
1.	Inspect the salt system for evidence of leaks and insulation damage. This is a general inspection for any condition that appears abnormal. If a problem is detected (i.e. salt leak, etc.), a more thorough inspection will be required.									
	<ul style="list-style-type: none"> <li>o RS tower piping</li> <li>o Surge Tanks (2 ea)</li> <li>o Valves (21 ea)</li> </ul>									
2.	Verify the following valve alignment. Coordinate with Emcon operator.									
	<table border="0"> <tr> <td>FCV-101</td> <td>OPEN</td> </tr> <tr> <td>FCV-102</td> <td>OPEN</td> </tr> <tr> <td>FCV-180 thru 189</td> <td>CLOSED</td> </tr> <tr> <td>FCV-190 thru 198</td> <td>CLOSED</td> </tr> </table>	FCV-101	OPEN	FCV-102	OPEN	FCV-180 thru 189	CLOSED	FCV-190 thru 198	CLOSED	
FCV-101	OPEN									
FCV-102	OPEN									
FCV-180 thru 189	CLOSED									
FCV-190 thru 198	CLOSED									
3.	Open the Receiver Cavity Door and inspect Receiver Assembly for evidence of leaks (white on black surface) and general condition. Close the door when the inspection is complete. Coordinate with Control Room.									
4.	Secure remote camera.									
5.	Verify with control room to switch heat tracing to remote.									
6.	Close the Cold Surge Tank and Receiver pneumatic backup supply bottles handvalves. Record values, CST = _____ p/Air = _____.									
7.	Turn off the Tower Air Compressor only after obtaining clearance from Control Room. (It may still be in use for HRFS or Facility).									
8.	Note any items or abnormalities encountered during test activities.									
9.	Advise the control room that RS post-test checklist has been completed and the RS is secure.									

A. LT-151 Calibration

This procedure will be utilized periodically to verify the calibration of LT-151 cold surge tank level control.

<u>STEP</u>	<u>DESCRIPTION</u>	<u>VERIFICATION</u>
1.	Verify completion of receiver start-up (GROP #2), defocus heliostats and close door.	_____
2.	Deactivate receiver control algorithm (by taking RCA off-scan).	_____
3.	Change the salt flow control setpoint (FD-101) to 60.0 Klbm/hr and wait for flowmeter to stabilize at 60.0 Klbm/hr.	_____
4.	Change the cold surge tank level (LT-151) setpoint to 95" and wait for C.S.T. level to stabilize.	_____
	Record LT-151 _____ (P <sub>1</sub> ) PT-182 _____ FT-101 _____	_____
5.	Change the cold surge tank level (LT-151) setpoint to 25" and wait for C.S.T. level to stabilize at 25".	_____
	Record (P <sub>2</sub> ) PT-182 _____ (L <sub>2</sub> ) LT-151 _____	_____
6.	Calculate a new surge tank level, using the following formula:  $L_1 = 99 - \frac{[P_2 + 12]}{[P_1 + 12]} (99 - L_2)$ $L_1 = \text{_____} \text{ in.}$	_____
7.	Change C.S.T. level (LT-151) setpoint to 95" and wait for C.S.T. level to stabilize.	_____
	Record (New L <sub>1</sub> ) LT-151 _____ (New P <sub>1</sub> ) PT-182 _____	_____
8.	Verify receiver subsystem is at warm standby and in a safe condition to allow personnel access to LT-151 level transmitter.	_____
9.	Change LT-151 span to match calculated value.	_____
10.	Repeat Steps 5, 6, 7 & 9 (minimum one time) as required.	_____
11.	Perform receiver shutdown (ROP #3).	_____
12.	Verify zero level on LT-151 at EMCON.	_____

B. FT-101 Calibration

This procedure will be utilized periodically to verify the calibration of FT-101 receiver salt flow control.

<u>STEP</u>	<u>DESCRIPTION</u>	<u>VERIFICATION</u>
1.	Set FT-101 to Zero prior to start-up.	_____
2.	Set receiver flow to 25 Klb/hr.	_____
3.	Change FCV-201 setpoint to 50". Continue when sump level rises to 50".	_____
4.	Deactivate FCV-101 and 102. Set both valves to <u>76</u> % closed. (This should maintain flow at 50 Klb/hr.)	_____
5.	Verify FCV-151 is fully open, then deactivate FCV-151. (This will maintain FCV-151 full open).	_____
6.	Deactivate ALGPID and set to 50% output. (Removes FD/FT compensation)	_____
7.	Check LT-151 is constant.	_____
8.	Close FCV-211.	_____
9.	Record change in sump level every 10 seconds.	_____
10.	When LT-201 reaches 30", open FCV-211.	_____
11.	If another measurement is to be made, allow sump to refill to 50". If measurement is complete, change FCV-201 setpoint to 23" and allow system to stabilize.	_____
12.	Compare FT-101 to calculated rate.	_____
13.	Adjust range as required.	_____
14.	Repeat steps 3 through 8, as required.	_____
15.	Activate FCV-151.	_____
16.	Verify sump level control is set at 23".	_____
17.	Activate FCV-101 and 102.	_____
18.	Activate ALGPID	_____
19.	Input desired flowrate into FD-101.	_____
20.	Allow system to stabilize.	_____



TOP #1 TSS PRETEST CHECKLIST

Test Date  
10/18/84

This Thermal Storage operating procedure will be utilized to verify TSS integrity prior to all tests that use Molten Salt. It shall be performed by the TSS tech.

<u>STEP</u>	<u>DESCRIPTION</u>	<u>VERIFICATION</u>
1.	Inspect the salt system for evidence of leaks and insulation damage. This is a general inspection for any condition that appears abnormal. If a problem is detected, a more thorough inspection will be required. <ul style="list-style-type: none"><li>o TSS salt piping</li><li>o Hot, Cold, and Booster Pumps and Sumps</li><li>o Vents</li><li>o Valves</li></ul>	_____
2.	Check for visual evidence of blown fuses, burned relays or burned electrical components in the power junction boxes and generally throughout the TSS.	_____
3.	Verify that the EPS Power Supply (lower part of rack) is set to 24 VDC and is ON.	_____
4.	Start/verify the air compressors are ON with a 80 psig supply pressure. Drain water from old compress tank.	_____
5.	Inspect the fan and louvers in the pump house for proper operation. Verify that the fan thermostat is set to 70°F.	_____
6.	Open the hand valve HV-284 at the old air compressor	_____
7.	Verify coolant flow through the HSP and BP bearings (piping will be cold with indication on the flow meter).	_____
8.	Verify the HSP, CSP and BP circuit breakers are off and the shafts of all three pumps are free. (Bump BP to verify freedom with C.B. On in local).	_____
9.	Turn on the HSP, CSP and BP circuit breakers and place the controls for the pumps in Auto. and verify air flow through the Cold Salt Pump bearings.	_____
10.	Using a probe, verify the C.S., C.T., H.S., H.T., and Booster Pump Sump vents are free of frozen salt. During routine operation, only intermittent verification is required. Particularly verify prior to restart after a shutdown or if pluggage is suspected from high salt levels (CS 60", HS 45").	_____

TOP #1 TSS PRETEST CHECKLIST

---

STEP      DESCRIPTION      VERIFICATION

11. Turn ON the TSS/SGS backup pneumatic air supply as follows:

- a) Verify supply bottles are at 300 psig minimum
  - b) Open the valves on the supply bottles and main isolation valve
  - c) Adjust the regulator to 50 psig
- 

12. Check coolant pumps and radiators for leaks and proper operation. Verify that HV-290, 291, 292, and 293 are open. At the beginning of each month, check the level in the radiators and fill if necessary.

---

CAUTION

Verify valve temps with control room prior to cycling.

NOTE

Heat tracing Auto Control may be overridden from Salt Storage Control Room and manually controlled, if required.

13. Align/verify the valve positions listed below. Coordinate with Emcon operator.

---

<u>Valve</u>	<u>Description</u>	<u>Position</u>	<u>Air Press.</u>
FCV-151	Cold Surge Level	Closed/N	
FCV-161	Hot Tank Inlet	Closed/N	
FCV-162	Cold Tank Inlet	Closed/N	
FCV-199	Bypass	Open/N	30 psi
FCV-201	Cold Sump Level	Closed/N	
FCV-211	Cold Sump Isolation	Closed/Locked	40 psi
FCV-221	Hot Sump Level	Closed/N	
FCV-231	Hot Sump Isolation	Closed/Locked	40 psi
FCV-241	Propane Heater Flow	Closed/Locked	
FCV-242	Propane Heater Isolation	Closed/Locked	30 psi
FCV-301	Bypass Salt Flow Control	Closed/N	
FCV-341	Cold Salt Isolation	Closed/N	
FCV-351	Hot Salt Isolation	Closed/N	

14. For operation with Propane Heater instead of Receiver, OR for SGS alone, Modify the valve alignment of step 13 as follows:

---

FCV-162      Open/N  
 FCV-242      Neutral

15. For operation without SGS, Modify the valve alignment of step 13 as follows:

---

FCV-301      Locked  
 FCV-341      Locked

TOP #1 TSS PRETEST CHECKLIST

<u>STEP</u>	<u>DESCRIPTION</u>	<u>VERIFICATION</u>
16.	Align/Verify the hand valve positions listed below: HV-280 HS/CS Tie Closed HV-281 HT/CT Tie Closed	_____
17.	Determine if the OLIN Salt Test Loop is to be used. If it is, align these HV's accordingly (with SGS only): HV-282 Salt Inlet Open HV-283 Salt Outlet Open	_____
18.	Set up the Eppley sun meter insolation instrument. It is located on a post south of the TSS. (Emcon 'SUN'). a) Rotate platform of tracker (by hand) to acquire sun. Fine adjust using azimuth and elev. screw adjust. (Sun dot should be in center of target on rear of instr.) b) Open door of timer box located on post. Rotate timer (turn on) to appropriate run time. (Adjust to approx. one half hour past shut-down). Close timer door c) Verify operation. Listen for tracker motor running. Recheck sun target on Eppley, readjust using thumb screws. Tighten lock screws.	_____
19.	Advise the Control Room that the TSS Pretest checklist has been completed.	_____

NOTE

Complete the SGS pretest checklist (SOP #1) and/or  
Local Propane Heater startup (TOP #2A) as required.

20. During Monday operations obtain hot and cold salt samples.  
Label each sample with Date, Time, Hot or Cold salt sample,  
Location where sample obtained, and any special or unusual  
conditions. Send samples to:

Monday Only

Olin Chemicals  
I-10 West/P.O. Box 2896  
Lake Charles, LA. 70602  
Attn: A. B. Quakenbush  
(318-491-3096)

The Propane Heater is used to charge hot salt when weather conditions do not allow adequate solar charging or when the Receiver or Collector subsystems are not on line.

This Thermal Storage operating procedure shall be performed by the Emcon operator. Periodically advise the TSS technician of status.

Turn on propane inlet and outlet lines trace heater circuits (TEH 223, TEH 224, and TEH 239 for temperature readings) a minimum of 10 hours prior to intended usage of the Propane Heater.

<u>STEP</u>	<u>DESCRIPTION</u>	<u>VERIFICATION</u>
1.	Verify completion of the following checklists: <ul style="list-style-type: none"> <li>◦ COP #1 Control Room pretest checklist</li> <li>◦ TOP #1 TSS pretest checklist</li> </ul>	_____
2.	Instruct/Confirm TOP #2A Local Propane Heater Start-up.	_____
3.	Record the time upon notification from the TSS technician that the Propane Heater is on Main Flame with 600°F stack outlet temperature. (Ref: steps 8 and 10).	_____
<u>CAUTION</u>		
Do not prolong heater warm-up past 20 minutes.		
05 4.	Verify Cold Tank level LT-281 is greater than 30 inches. If the SGS is operating (on-line) continue at step 9.	TIME _____
5.	Place FCV-211 in neutral and fully open; verify micros.	_____
6.	Verify/increase the Cold Sump Level to 50 inches, (60" max).	_____
7.	Activate the FCV-201 Cold Sump Level Control with a set point of 23 inches.	_____
04 8.	14 minutes after MAIN FLAME (step 3) start Cold Pump.	_____
9.	Verify Cold Pump outlet pressure PT-180 increases to greater than 170 psi.	_____

NOTE

The Hot Tank must be precharged to 750°F prior to introduction of any high temp. salt. During precharge, leave FCV-221/231 open until the Hot Sump level increases (40" max.), then quickly close FCV-221/231.

TOP #2 PROPANE HEATER PROCESS START-UP

---

<u>STEP</u>	<u>DESCRIPTION</u>	<u>VERIFICATION</u>
05 10.	Initiate salt flow through the Propane Heater 15 minutes after completing step 3; Unlock and open FCV-241 to to 50% open.	_____
05 11.	Open FCV-242. Record Time.	_____

Time

NOTE

It will take approximately 10 minutes for the salt to flow through the Propane Heater. Monitor Acurex channel 142 and LT-291 for verifying flow through the heater.

12. Advise the TSS technician to turn off the trace heater L6-1 and inlet to Hot Tank if TEH-239 salt temperature will be exceeding 750°F. Verify. \_\_\_\_\_
  
13. Adjust the Propane Heater for a 1050°F (or desired temperature) salt outlet temperature by accomplishing the following after salt flow into hot tank verified (LT-291 10 minutes later):
  - a. Advise the TSS technician to set the Burner Temperature control to 1100-1200°F stack temperature. \_\_\_\_\_
  - b. Use TEH-239 (Acurex channel 142) as the actual salt salt outlet temperature indication (1040°F max.). Actual temperature approximately 50°F higher than channel 142 read-out at high (1000 °F) temperatures; approximately 20°F higher at low (700°F) temperatures.
  - c. Adjust FCV 241 to TBD% (approximately 40 to 55% for 750-900 F salt and ~~35~~-40% for 900-1050 salt). If 1050 salt is desired place stack tempature at 1250 and start with FCV 241 at 50% and adjust accordingly. \_\_\_\_\_
  - d. Monitor Acurex channels 134/136 as hot tank salt temperature and EMCON TE-291.

THE PROPANE HEATER IS NOW ON-LINE AND CHARGING SALT

This Thermal Storage operating procedure will be utilized to locally operate the Propane Heater in conjunction with Emcon (Propane Heater) process operation. This procedure shall be performed by the TSS technician.

<u>STEP</u>	<u>DESCRIPTION</u>	<u>VERIFICATION</u>
1.	Place switch on local console to off position and temperature control to 200°F.	_____
2.	Check level of the Propane Tank and verify sufficient propane for present test - 15% or 900 gallons minimum.	_____
3.	Check/ignite pilot lights of propane evaporators:	
	A. If vaporizers are not lit, then remove small square cover on south side. Turn knob to pilot.	_____
	B. Open center cover (west side) to get to pilot. Pilot is located between metal cylinders at the bottom.	_____
	C. While holding knob on south side in full C.C.W. position, light pilot.	_____
	D. Hold in this position for 30 to 60 seconds, then turn to on position. Replace covers slowly or flame may go out.	_____
4.	Open all three evaporator outlet hand valves (top east side of evaporators) fully. Pressure gauge at Heater inlet should read 55 to 60 psi.	_____
5.	Check pressure gauge bottom north side of heater. The reading should be about 8 oz.	_____
6.	Place Burner switch on local console to preheat.	_____
7.	Turn on power switch - red power and timer light should come on.	_____
8.	Timer light will remain on for about 2 min. as system is purged prior to introduction of pilot flame gas. Timer light will then go off and about 20 sec. later both timer and pilot light will come on to ignite the pilot flame. If IR scanner does not detect a pilot flame within 6 sec., the start sequence will be stopped and the timer will reset and start over. When the pilot flame is achieved, the PILOT LIGHT will come on.	_____

TOP #2A LOCAL PROPANE HEATER START-UP

<u>STEP</u>	<u>DESCRIPTION</u>	<u>VERIFICATION</u>
	<p style="text-align: center;"><u>WARNING</u></p> <p style="text-align: center;">If pilot flame does not light after two tries, close valve on vaporizer and troubleshoot system.</p>	
9.	After pilot is lit for about 1 minute, switch to main flame, set temperature control to 250°F and allow to soak for three minutes minimum.	_____
10.	Slowly advance temperature control to 600°F - do this slowly to avoid screeching of heater. Main flame light should stay lit.	_____
11.	Notify Control Room that the Propane Heater is on Main Flame with a 600°F stack outlet temperature (awaiting 15 min. heat soak prior to process operation).	_____

WARNING

Proceed with propane heater operation within 15 minutes of heat soak or lower stack temperature back to 250 F. Return stack temperature to 600 F before charging salt.

TROUBLE SHOOTING GUIDE

Signs of trouble are:

1. Low or very high reading at pressure gauge.
2. Stack temperature varies or stays low.
3. Unit will not start, no pilot.

All the above can be caused by the vaporizers not being lit. Any vaporizer that is out can cause these troubles.

If the heater is running and frost can be noted on the fuel lines, DO NOT TURN HEATER OFF. Relight the vaporizer(s) that are out and continue to run at reduced temperature until the frost is gone.

If you cannot get the vaporizer to light, turn off the hand valve and let the heater run until frost has left the lines. Heater will run on one vaporizer at reduced output. Try to get at least one lit to help remove the liquid propane from the lines.

If the heater will not light, check to see if the ignition wire on bottom of the heater is on the plug.

This Thermal Storage operating procedure shall be completed by the Emcon operator. Periodically advise the TSS technician of status.

STEP      DESCRIPTION      VERIFICATION

NOTE

When shutting down the Propane Heater in conjunction with the SGS (both in operation), perform SOP #5 - not this procedure.

- 05 1. Advise the TSS technician to adjust the burner temperature Control to 600°F stack temperature when the Hot Tank level LT-291 is within 12 inches of the desired level (or within 7 inches of desired level in the Cold Tank). \_\_\_\_\_
- 05 2. Open FCV-241 to 60%. \_\_\_\_\_
- 04 3. When 2 inches from desired level, or when channel 142 reads 800°F, deactivate FCV-201 Cold Sump Level Control. \_\_\_\_\_
- 04 4. Close FCV-201 and FCV-211 (manually lock closed). \_\_\_\_\_
- 04 5. Turn off the Cold Pump when it cavitates. (PT-180 drops below 165 psig, LT-201 approx. 11.5"). Record Time. (Ref. steps 7 and 8). \_\_\_\_\_  
TIME
- 05 6. Open FCV-241 to 100% open. \_\_\_\_\_
- 02 7. Wait 2 minutes to allow salt drainage, then unlock and open FCV-151 and FCV 161. \_\_\_\_\_

NOTE

LT-201 will increase to approximately 58 inches during propane heater draining.

- 8. Advise the TSS technician to shutdown the Propane Heater 30 minutes after Cold Pump shutoff (step 5) with TOP #3A. \_\_\_\_\_
- 05 9. Close FCV-241, FCV-242. \_\_\_\_\_
- 10. Advise the TSS technician of the following days operating requirements for heat trace actuation. \_\_\_\_\_
- 11. Verify Propane Heater shutdown from TSS technician. \_\_\_\_\_
- 12. Advise the TSS tech to complete TOP #4 as required. \_\_\_\_\_



This Thermal Storage operating procedure will be utilized to locally shut down the Propane Heater after Emcon (Propane Heater) process operation. This procedure shall be performed by the TSS technician.

<u>STEP</u>	<u>DESCRIPTION</u>	<u>VERIFICATION</u>
1.	Turn stack temperature control to 600°F when directed to do so by Emcon operator.	_____
2.	After cold salt pump has been turned off, allow a minimum of 30 minutes to drain.	_____
<u>NOTE</u>		
If shutdown includes SGS, the Cold Pump may be restarted to deplete the cold sump. Allow full 30 minutes drain time.		
3.	Turn main flame/preheat switch to preheat.	_____
4.	Turn temperature to 200°F.	_____
5.	Turn power off.	_____
6.	Close the 3 evaporator outlet hand valves to avoid the collection of liquid propane in the line.	_____
7.	Adjust the Propane Heater heat tracing as follows:	
a.	For Propane Heater use the following day, Turn on the Propane Heater outlet line LG-1 and Hot Tank inlet heat trace.	_____
b.	If Propane Heater is not to be used the following day, turn off the Propane Heater inlet line heat trace (TEH-223, 224).	_____
8.	Advise the Control Room that the Propane Heater is shutdown.	_____

This Thermal Storage Operating procedure will be utilized to verify TSS integrity following all tests that use the TSS. This checklist shall be completed by the TSS technician.

<u>STEP</u>	<u>DESCRIPTION</u>	<u>VERIFICATION</u>
1.	Complete the SGS post test checklist SOP #4 (first) if no further SGS operation planned.	_____
2.	Inspect the salt system for evidence of leaks and insulation damage. This is a general inspection for any condition that appears abnormal. If a problem is detected, a more thorough inspection will be required. Particularly inspect: <ul style="list-style-type: none"> <li>◦ TSS salt piping</li> <li>◦ Hot, Cold, and Booster Pumps and Sumps</li> <li>◦ Vents</li> <li>◦ Valves</li> </ul>	_____
3.	Check for visible evidence of blown fuses, burned relays, or burned electrical components in the power junction boxes and generally throughout the TSS.	_____
4.	Verify with control room to switch and leave applicable heat tracing control to auto.	_____
5.	Close and Lock these valves, Verify. FCV-211 Close/Lock FCV-231 Close/Lock	_____
6.	If the Olin test loop was used, close HV-282 and HV-283.	_____
7.	Turn off the CSP, BP, and HSP local starter circuit breakers.	_____
8.	Turn off the CSP bearing cooling air HV-284.	_____
9.	Secure the TSS/SGS back-up pneumatic air by closing the supply bottles HV's.	_____
10.	Leave both Air Compressors On.	_____
11.	Leave TSS coolant pump and radiator On.	_____
12.	Advise the Control Room that the TSS post test checklist is complete and the TSS is secure.	_____

A. HOT TANK TO COLD TANKI. Gravity Transfer (700 F maximum)

1. Verify completion of the following checklists.  
Particularly verify TSS heat trace temp's and valve align.
  - COP #1 Control Room pretest checklist
  - TOP #1 TSS pretest checklist
2. Verify FCV-211 and 231 manually closed and locked.
3. Open HV-281.
4. Open FCV-201 and 221.

(Salt flow rate starts to lessen when LT-291 passes 50".  
Gravity transfer can take the Hot Tank down to approx. 30".)

II. C.S. Pumped Transfer to C.T.

1. Verify RS heat trace temps are OK ( COP #1 Table A ).
2. Start off with Gravity Transfer to ensure proper flow
3. Close FCV-101/102. (For safety - not really required)
4. Open FCV-162 and FCV-199 (verify micro's).
5. Unlock and place FCV 211-in neutral.
6. Ensure LT-201 is greater than 50" (Open/close FCV-211).
7. Start the CSP verify PT-180 increases to over 150 psi.
8. Close FCV-201.
9. Open FCV-211.
10. Incrementally open FCV-151 to approximately 40%.

NOTE

Maintain Cold Sump level at 25" by varying FCV-151 setting.  
(Setting will need to decrease as LT-291 decreases.)

III. Shutdown

11. When reaching desired LT-291 level, perform the next steps expeditiously:
  - a. Close FCV-151
  - b. Turn off the CSP and BP
  - c. Close FCV-221 and FCV-201
  - d. Close FCV-211 (and manually lock it).
  - e. Close HV-281.
12. After 2 minutes, Open FCV-151, 101, 102, (and FCV-161 if elbow is above 480°F) to drain back residual salt.
13. After 5 minutes, close FCV-151, 161, and 162.

B. HOT SUMP TO COLD TANKI. C.S. Pumped Transfer to C.T.

1. Valve Configuration per COP #1 Part VI TSS. \_\_\_\_\_
2. Verify transfer line and HV-280 are greater than 450°F by local T/C check. \_\_\_\_\_
3. Close FCV 101/102 (for safety not really required.) \_\_\_\_\_
4. Verify FCV-221 and 231 manual closed and lock FCV-231. \_\_\_\_\_
5. Open FCV-162 and FCV-199 (verify micros). \_\_\_\_\_
6. Place FCV-201 in Automatic Control with a set point of 50 inches. \_\_\_\_\_
7. Unlock and place FCV-211 in neutral. \_\_\_\_\_
8. Open FCV-211. \_\_\_\_\_
9. Ensure LT-201 is approximately 50 inches and change FCV-201 set point to 25 inches. \_\_\_\_\_
10. Start the CSP and BP and verify PT-180 increases to over 300 psi. \_\_\_\_\_
11. In 10% increments open FCV-151 to approximately 40%. \_\_\_\_\_

NOTE

Circulation of salt must stabilize at a sump level (LT-201) of approximately 25 inches. Monitor LT-151 and LT-161 levels.

II. H.S. Pumped Transfer to C.S.

12. Open HV-280. \_\_\_\_\_
13. Turn on Hot Salt Pump. \_\_\_\_\_

III. Shutdown

14. When reaching desired LT-221 level:
  - a) Turn off Hot Salt Pump
  - b) Close HV-280
 \_\_\_\_\_
15. When LT-201 stabilizes at approximately 25 inches:
  - a) Close FCV-151
  - b) Turn off BP and CSP
  - c) Close FCV-211 (and manually lock it)
  - d) Deactivate and manually close FCV-201
 \_\_\_\_\_
16. After 2 min., open FCV-151, 101, 102 (and FCV-161 if elbow is above 480°F) to drain back residual salt. \_\_\_\_\_
17. After 5 min., close FCV-151, 161 and 162. \_\_\_\_\_

This Steam Generation operating procedure will be utilized to verify SGS integrity prior to all tests that use the SGS. This checklist shall be completed by the SGS technician. This checklist presumes SGS is in Diurnal Shutdown.

<u>STEP</u>	<u>DESCRIPTION</u>	<u>VERIFICATION</u>										
1.	Verify completion of TOP #1 TSS pretest checklist.	_____										
2.	Inspect the salt system for evidence of leaks or damage. This is a general inspection for any condition that appears abnormal. If a problem is detected, a more thorough inspection will be required. <ul style="list-style-type: none"> <li>◦ All SGS salt piping</li> <li>◦ Valves</li> <li>◦ Superheater and Evaporator</li> </ul>	_____										
3.	Inspect the water/steam system similarly: <ul style="list-style-type: none"> <li>◦ SGS piping</li> <li>◦ Valves, traps</li> <li>◦ BWCP</li> <li>◦ Flange Connections</li> <li>◦ Drain Plugs</li> <li>◦ Superheater</li> <li>◦ Evaporator</li> <li>◦ Steam Drum</li> <li>◦ Attemperator</li> <li>◦ Drain and Blowdown Tank</li> </ul>	_____										
4.	Check for visual evidence of blown fuses, burned relays or burned electrical components in the power junction box and generally throughout the SGS.	_____										
5.	Intermittantly verify these amperages with a clamp-on Ammeter. Caution - 480V. <ul style="list-style-type: none"> <li>A. Circ. Heater               <table style="margin-left: 40px;"> <tr> <td>EH-1</td> <td>28A</td> </tr> <tr> <td>EH-2</td> <td>28A</td> </tr> <tr> <td>EH-3</td> <td>16A</td> </tr> <tr> <td>EH-4</td> <td>16A</td> </tr> <tr> <td>EH-5</td> <td>16A</td> </tr> </table> </li> <li>B. BWCP            Each Phase    7.8A</li> </ul>	EH-1	28A	EH-2	28A	EH-3	16A	EH-4	16A	EH-5	16A	_____
EH-1	28A											
EH-2	28A											
EH-3	16A											
EH-4	16A											
EH-5	16A											
6.	If freezing ambient temperatures have been experienced, Verify operability - Unthaw the following: <ul style="list-style-type: none"> <li>A. Instrument Transmitters - particularly LT-311 - open xmtr piping drain valves for 10-15 sec. intervals - work with system temp. increases.</li> <li>B. Steam Traps - T-481/HV-491 and T-482/HV-487 - open 1/4 turn and listen for flow. Externally heat as necessary. Open fully after 10 minutes.</li> </ul>	_____										

SOP #1 SGS PRETEST CHECKLIST

<u>STEP</u>	<u>DESCRIPTION</u>	<u>VERIFICATION</u>
7.	SGS water chemistry sampling -	
A.	Obtain a drum water sample by opening HV-386, flushing the sample station lines for 10 minutes, then filling a one liter sample bottle.	_____
B.	Analyze and Evaluate the sample per HOP #6.	_____
C.	Conduct a Millipore filter sampling and analysis for suspended iron. Results of this must be added to the HOP #6 dissolved iron determination for comparison to the 500 ppb limit.	_____
D.	Close HV-386 upon completion of sampling and Open the vent HV-384 located adjacent to HV-386 to drain the sample line, particularly to protect against freezing. Close the vent HV-384 after totally draining the line.	_____

8. SGS Phosphate injection -

- A. As determined by water chemistry sampling of step 7, phosphates can be added to the SGS with the chemical feed station on the SGS skid (HV-387/388). Injection should be started as early as possible. \_\_\_\_\_
- B. The phosphate injection mixture consists of 175 grams of granular Trisodium Phosphate and 50 grams of powdery Disodium Phosphate mixed with 2 and 1/2 gallons of demineralized water \_\_\_\_\_

CAUTION

Verify valve temps with control room prior to cycling.

NOTE

Heat tracing auto control may be overridden from Salt Storage Control Room Acurex cabinet and manually controlled, if req'd.

- 9. Align/Verify the valve positions listed below. Coordinate with Emcon operator.

<u>Valve</u>	<u>Description</u>	<u>Position</u>
FCV-321	Main Salt Flow	Open
FCV-331	Steam Attemperator	10% Open
FCV-381	Evap. Salt Drain	Open
FCV-382	Superhtr. Salt Drain	Open
FCV-383	Circ. Htr. Bypass	Closed
FCV-384	Circ. Htr. Supply	Open
FCV-491	Steam Delivery	Closed

SOP #1 SGS PRETEST CHECKLIST

<u>STEP</u>	<u>DESCRIPTION</u>	<u>VERIFICATION</u>
-------------	--------------------	---------------------

10. Align/Verify the following valve positions.

<u>Valve</u>	<u>Description</u>	<u>Position</u>
HV-370	Bridge Feedwater Drain	Closed
HV-371	Circ. Heater Drain	Closed
HV-372	BWCP Volute Drain	Closed
HV-373	BWCP Bearing Cavity	Closed
HV-375	SGS Air Supply	Open
HV-381	Drain	Closed
HV-382	Blowdown Control	Closed
HV-383	Blowdown Isolation	Closed
HV-384	Pump Isolation	Open/Locked
HV-385	Steam Drum Vent	Closed
HV-386	Sample Line Isolation	Closed
HV-387	Chemical Feed Metering	As needed
HV-388	Chemical Feed Isol.	As needed
HV-389	Chemical Feed Drain	Closed
HV-390	Drum N <sub>2</sub> Inlet	Closed
HV-481	Steam Delivery Isol.	Closed
HV-485	Steam Delivery Drain	Closed
HV-486	Steam Delivery Drain	Closed
HV-487	Trap Isolation	Open
HV-488	Feedwater Supply Isol.	Closed
HV-491	Steam Trap Isol.	Open

11. After HRFS start-up, coordinate with the Control Room to replenish SGS water. Particularly operate HV-370 and HV-488 as needed. Leave HV-370/488 closed. Alternatively, fill SGS with the chemical feed pump on the SGS skid.

12. Advise the Control Room operator that the SGS pretest checklist has been completed.

NOTE

After operation is established and consent obtained from the Control Room, Blowdown the steam drum to reduce high Iron and TDS concentrations found by the water chemistry analysis. The blowdown period using HV-382 and HV-383 shall be as follows:

<u>Iron (ppm)</u>	<u>TDS (ppm)</u>	<u>Blowdown Time</u>
200	50	0 Minute
200 to 300	50 to 100	1 Minute
300 to 500	100	2 Minute

Blowdown will only help remove dissolved solids Periodically drain certain dead legs in the SGS using HV-371 and HV-372 to remove suspended solids.

## SOP #1 SGS PRETEST CHECKLIST

### CHEMICAL FEED PUMP OPERATION

This pump is to be used for phosphate addition or make-up for drum level. The pump and holding tank will be drained for freeze protection.

- 1) If pump needs to be primed, the following should be done:
  - a) Close discharge valve HV-387
  - b) Open drain valve on pump
  - c) Allow water to flow from the holding tank through the pump and out the drain valve
  - d) Close drain valve once flow is established
  - e) Open discharge valve HV-387
- 2) The pump can be started after being primed. The following should be verified:
  - a) Discharge valves HV-387 and HV-388 are opened
  - b) Pump is primed
  - c) Holding tank is full
  - d) Door closed on pump cover
  - e) Start pump and have control room monitor drum level
- 3) Shutdown pump and drain it if necessary.

### OPERATION PRECAUTIONS

- 1) This is a high pressure discharge pump. Avoid leaving pump house door open when operating.
- 2) If pump is dead headed the unloader will relieve to the suction line.
- 3) Always man pump during any operation.



This Steam Generation Operating Procedure shall be performed by the Emcon operator. Periodically advise the SGS technician of status. This procedure assumes SGS is in Diurnal Shutdown.

<u>STEP</u>	<u>DESCRIPTION</u>	<u>VERIFICATION</u>
-------------	--------------------	---------------------

A. DIURNAL SHUTDOWN TO WARM STANDBY MODE

1. Verify completion of the following checklists:

- COP #1 Control Room pretest checklist
- TOP #1 TSS pretest checklist
- SOP #1 SGS pretest checklist
- HOP #1 HRFS pretest checklist and local startup
- HOP #2 HRFS startup

CAUTION

If freezing temperatures have been experienced, be aware of possible bad SGS instrument readings.

- |    |    |                                                                                                                                                          |  |
|----|----|----------------------------------------------------------------------------------------------------------------------------------------------------------|--|
| 18 | 2. | Verify D/D temp TE-451 (H1 or H2) is above 250 F, then position FCV-431 to Manual and open to start steam pipe heat-up with D/D steam.                   |  |
| 02 | 3. | If R.S. is not operational, check Acurex channels 121, 129, and 131 are above 480°F and reverify FCV-151 and 161 are closed and locked, FCV-162 is open. |  |
| 16 | 4. | Place/verify MAN.EHAC and EHAC are ON. This places the Circulation Heater in Automatic Pressure Control. Also, verify MAN.ESH-1 thru MAN.ESH-5 are off.  |  |
|    | 5. | Place/verify MAN.SDC is ON and SDC is OFF (These may have to be on to override Hi steam drum levels)                                                     |  |
|    | 6. | Place/verify FCV-321, and 331 are in cascade, at the N90 console Groups H & F, (Ready for N90 control after EMCON control deactivated)                   |  |
|    | 7. | Verify the following set points:                                                                                                                         |  |
| 13 |    | SP.EST 850°F Evaporator Salt Temperature (FCV-301)                                                                                                       |  |
|    |    | SP.SP 1100 psi Steam Delivery Pressure (FCV-321)                                                                                                         |  |
|    |    | SP.ST 970°F Steam Delivery Temperature (FCV-331)                                                                                                         |  |
|    |    | SP.DL -2.0" Steam Drum Level (FCV-411)                                                                                                                   |  |
| 18 | 8. | Verify D/D Feedwater temperature at TE-451 is at 250°F.                                                                                                  |  |

SOP #2 SGS START-UP (EMCON)

STEP	DESCRIPTION	VERIFICATION
9.	Note the Steam Drum Temperature at TE-383. The temperature must be above 500°F to initiate salt flow. If the temperature is below 500°F, wait for circulation heaters to increase the temperature above 500°F prior to proceeding.	_____
10.	Verify cold sump temp. Accurex channel 124 and 125 are within 100°F of TE-383 to prevent shocking the superheater. If difference is over 100°F, continue to heat SGS to within 100°F with circulation heaters.	_____
11.	Reverify salt path temperatures are acceptable Ref. COP #1 Table B & C.	_____
12.	Advise the SGS technician to open HV-481 (ahead of FCV-491) and Verify HV-488 is Open.	_____
13.	Activate FCV-411; Emcon MAN.411 OFF, Net 90 FCV-411 in cascade.	_____
14.	Have field technician unlock FCV-211.	_____
18 15.	Activate FCV-431 casc. control via PT-431 SP 1080 psi.	_____
16.	Reduce FCV-401 set point from 1250 to 1050 in two steps.	_____

NOTE (CONTROL ROOM)

Monitor PT-321 and reduce set point of FCV-491 as required to maintain a constant drum level during auto SGS.CF sequence.

NOTE (CONTROL ROOM)

If LT-311 reaches 6" turn SDC ON.

17. Close salt drain valves after verifying Acurex channel 261 thru 264 are above 480°F by turning FCV-38182 OFF and MAN. 38182 ON. Verify closure.

NOTE

The SGS cold flow auto sequence starts here. Monitor 'Control Room' Notes during auto sequence and perform as required.

12 18.  
GR 994

- Turn on SF to start cold flow auto sequence.

19. Open FCV-211, and activate FCV-201 with a level control set point of 50 inches. When level reaches 50 inches, change the setpoint to 23 inches, (60 inches max.)

20. Start the cold pump; PT-180 greater than 150 PSI before continuing.

21. Enable the following alarms:

PT-383      TE-301  
                 TE-384

SOP #2 SGS START-UP (EMCON)

<u>STEP</u>	<u>DESCRIPTION</u>	<u>VERIFICATION</u>
-------------	--------------------	---------------------

22. Set SP.341 to 100% to fully open FCV-341 and verify the position. This fills the SGS with cold salt in approx. 12 minutes.

NOTE (CONTROL ROOM)

1. Monitor LT-201 to maintain sump level above 12 inches. (Absolute minimum). Do not cavitate pumps.
2. If salt temps are low (550°F) turn on Net 90 heater 1 to protect against freezing. Heater 1 will turn off upon FCV-383/384 switchover.

TIME  
(REF STEP 23)

NOTE (CONTROL ROOM)

After opening FCV-341 monitor the SGS temperatures on Acurex and EMCON as listed below to verify that salt is flowing thru the SGS. Each Acurex chanel or EMCON Thermocouple read the same as the Cold Salt Temperature in the order listed:

	°F
	-----
	TE-382
	°F
TE382 (EMCON)	REF. COLD SALT TEMP
TE301 (EMCON)	(ACUREX CH 124/125)
TE384 (EMCON)	

If Channels 204, 255, 270, 254, 216, 215, 241, 203, 250, & 208 do not appear to be consistent with the Cold Salt Temperature, a blockage may exist. If so, OPEN FCV-301 fully to improve flow temporarily then CLOSE FCV-301 and monitor FT-321 to determine if the blockage has cleared.

NOTE (CONTROL ROOM)

When auto ramp is complete and LT-311 is below 7" turn SDC OFF

23. Once superheater is filled with salt, TE-301 should read cold salt temp (approx. 5 minutes after step 22). Open FCV-301 with SP.301 to 100% and verify position.

24. When FT-321 flow is greater than 10 Klb/hr., set SP.301 to 0% and turn MAN.301 OFF. Verify that FCV-301 closes.

NOTE

The SF cold flow auto sequence stops here. The next few steps will be performed manually.

12 25. Verify/turn off SF if it was used. (Turns itself off when auto start is complete).

<u>STEP</u>	<u>DESCRIPTION</u>	<u>VERIFICATION</u>
26.	Place FCV-301 in Cascade at the Network 90 to control Evaporator salt temperature at SP.EST.	_____
	<u>NOTE</u> Reactivate FCV-301 at Net 90 after any trip. SGS IS NOW IN WARM STANDBY (COLD FLOW) AWAITING INTRODUCTION OF HOT SALT	
<b>B. <u>WARM STANDBY TO THE ON-LINE CONDITION</u></b>		
	1. Verify FCV-221 is closed.	_____
13	2. Set MAN.331 to OFF to activate the FCV-331 Steam Delivery Temperature Control at SP.ST. Verify that FCV-331 closes and is in Casc. at Net. 90.	_____
	3. Verify/place FCV-231 in neutral.	_____
	<u>NOTE</u> The SGS auto ramp sequence starts here.	
12	4. Turn on SRU to start auto ramp sequence.	_____
	5. Set MAN.383 to ON and FCV-383 ON (Open) and verify Micro.	_____
	6. Set MAN.384 to ON and FCV.384 to OFF (Closed) and verify micro; verify that all circulation heater circuits are off.	_____
	7. Verify the CSP is operating and FCV-341 is open 100%	_____
	8. Activate the FCV-221 Hot Sump Level Control with a set point of 40 inches.	_____
	9. Open FCV-231, verify ZSL 231 is on.	_____
10.	When Hot Sump level reaches 40 inches, reset FCV-221 set point to 20 inches.	_____
	<u>NOTE</u> If hot sump level (LT-221) reaches 43", Emcon will automatically close FCV-231 and reopen it at 30". Lock-out may be overridden by turning OVR3 on.	
11.	Turn on the Hot Salt Pump.	_____

<u>STEP</u>	<u>DESCRIPTION</u>	<u>VERIFICATION</u>
-------------	--------------------	---------------------

NOTE

During the following activity of increasing salt temperature, verify the operation of FCV-432 so that deaerator pressure is held constant at 233 psi and all excess energy is being rejected by the cooling water circuit.

CAUTION

Monitor PT-382. If PT-382 pressure goes above 85 psig, close FCV-351.

12. Open FCV-351 then close FCV-341 in series using the following incremental steps to increase superheater inlet temperature (TE-382). The Operator shall monitor TE-382 to assure that TE-382 does not increase more than 100°F in any 6-minute period.

FCV-351 to 2% for 2 minutes	°F
" to 3% " " "	TE-382 TEMP
" to 4% " " "	
" to 5% " " "	°F
" to 6% " " "	Ref Hot Salt Temp
" to 7% " " "	(Acurex Ch 126/127)
" to 8% " " "	
" to 9% " " "	
" to 10% " " "	; maintains 10% position

FCV-341 to 80% for 1 minute	
" to 60% " " "	
" to 40% " " "	
" to 20% " " "	
" to 10% " " "	
" to 05% " " "	
" to 2.5% " " "	
" to 1.0% " " "	
" to 0% " " "	; maintain closed

13. Close FCV-321 to 50% by setting SP.321, wait 5 sec. then set SP.321 to 10%. Wait 5 sec., then set SP.351 to 50%. Wait 5 sec., then set SP.351 to 100%.
- 31 14. Enable the SGS operational alarms by turning SAL on and wait 30 seconds.

SOP #2 SGS START-UP (EMCON)

<u>STEP</u>	<u>DESCRIPTION</u>	<u>VERIFICATION</u>
15.	Set SP.321 to 20%, wait 20 seconds.	_____
16.	Set SP.321 to 30%, wait 20 seconds.	_____
17.	Set SP.321 to 40%, wait 20 seconds.	_____

NOTE

The SRU auto ramp sequence stops here

12	18. Verify/Turn off SRU if it was used. (Turns itself off when auto ramp-up is complete.	_____
18	19. Activate FCV-421 with a SP. of 520°F.	_____
13	20. Set drum level set point SP.DL to 0"	_____
18	21. Increase FCV-401 SP from 1050 to 1250 PSI in two steps.	_____

THE SGS IS NOW ON-LINE IN SALT FLOW CONTROL  
(FCV-321 manually controlling SGS salt flow  
and FCV-431 auto controlling HRFS steam pressure  
via PT-431 SP normally 1080 psi.)

22.	Advise the SGS technician that drum blowdown may now be performed if required. (As determined by his SGS pretest checklist water chemistry analysis.)	_____
-----	-------------------------------------------------------------------------------------------------------------------------------------------------------	-------

NOTE

The Turbine/Generator will normally be brought on line at this point (POP#2). To simulate the Turbine loading, complete the transfer from HRFS pressure control to SGS pressure control (next 2 steps) and manually position FCV-431 to vary the steam dump to the deaerator.

12	23. Set MAN.321 to OFF to activate SGS Steam Press. control. (FCV-321 auto controlling steam pressure at SP.SP 1100 psi.	_____
12	24. Deactivate the FCV-431 HRFS Steam Pressure Control and manually position valve to establish minimum steam flow (approx. 3 Klb/Hr.) and simulate steam loading.	_____

THE SGS IS NOW ON LINE IN AUTOMATIC BOILER FOLLOWING MODE.

This Steam Generation operating procedure shall be performed by the Emcon operator. Periodically advise the SGS technician of status.

<u>STEP</u>	<u>DESCRIPTION</u>	<u>VERIFICATION</u>
-------------	--------------------	---------------------

1. When steam demand has dropped to less than 3500 lbs/hr, switchover from SGS pressure control to flow control:
  - a) Set SP.321 value to the same value as shown on ZT321, or 50%.
  - b) Activate the FCV-431 HRFS Steam Pressure Control (using PT-431) with a set point of 1080 psig. Turn off GSTAT.
  - c. Deactivate the SGS Steam Pressure Control by turning MAN.321 ON.

NOTE

SRD auto ramp-down starts here

- |    |                                                                                                                                                                                                                                                                                                                                                                                                                                                                                                                                            |                                                                                                          |
|----|--------------------------------------------------------------------------------------------------------------------------------------------------------------------------------------------------------------------------------------------------------------------------------------------------------------------------------------------------------------------------------------------------------------------------------------------------------------------------------------------------------------------------------------------|----------------------------------------------------------------------------------------------------------|
| 12 | <ol style="list-style-type: none"> <li>2. Turn on SRD to start auto ramp-down sequence.</li> <li>3. Set SP.351 to 50% wait 5 seconds, then set SP. 351 to 10% wait 5 seconds, and set SP.321 to 50%, wait 5 seconds then set SP.321 to 100%.</li> <li>4. Open FCV-341 then close FCV-351 in series using the following incremental steps to decrease superheater inlet temperature (TE-382). The operator shall monitor TE-382 to assure that it does not decrease more than 100F° in any six minute period. Record start time.</li> </ol> | <hr/> <p style="text-align: center;">MAN    AUTO</p> <hr/> <p style="text-align: center;">Time</p> <hr/> |
|----|--------------------------------------------------------------------------------------------------------------------------------------------------------------------------------------------------------------------------------------------------------------------------------------------------------------------------------------------------------------------------------------------------------------------------------------------------------------------------------------------------------------------------------------------|----------------------------------------------------------------------------------------------------------|

SP.341 to 10% for 1 minute	
" " to 20% " " "	
" " to 30% " " "	
" " to 40% " " "	
" " to 50% " " "	
" " to 60% " " "	
" " to 70% " " "	
" " to 80% " " "	
" " to 90% " " "	
" " to 100% " " "	"; maintain open

°F  
TE-382

SP.351 to 6% for 1 minute	
" " to 4% " 3 "	
" " to 2% " " "	
" " to 1.5% " " "	
" " to 1% " " "	
" " to 0.5% " " "	
" " to 0% " " "	"; maintain closed

SOP #3 SGS SHUTDOWN (EMCON)

<u>STEP</u>	<u>DESCRIPTION</u>	<u>VERIFICATION</u>
04 5.	Turn off the Hot Salt Pump. N90 will hold FCV-351 closed if the Hot Salt Pump is not running.	_____
6.	Deactivate automatic control and close FCV-221. Verify closed.	_____
7.	Close FCV-231, and verify ZSL 231 is on. Have TSS tech. manually lock FCV-231 closed.	_____
13 8.	Deactivate the FCV-331 Steam Delivery Temperature Control by setting SP.331 to 10% and turning MAN.331 to ON.	_____
9.	Set FCV-384 to ON (Open) and verify the position on the micros.	_____
10.	Set FCV-383 to OFF (Close) and verify the position on the micros.	_____
<u>NOTE</u>		
SRD auto ramp-down stops here		
12 11.	Verify/turn off SRD if it was used. (Turns itself off when auto ramp-down is complete.	_____
12.	Verify MAN.EHAC ON, EHAC OFF and then back ON (pulse signal). TE-383 must be below 530°F.	_____

THE SGS IS NOW IN WARM STANDBY

NOTE

To maintain the Warm Standby condition accomplish the following:

- a) Verify salt system temperatures (COP #1 Tables A & B) are 480°F minimum.
- b) To maintain water/steam pressure at 1100 psig, reduce salt flow thru FCV-341 to lowest compatible with stable flow (still maintaining PT-383 at 1100 psig).

Extended Warm Stdby



SOP #3 SGS SHUTDOWN (EMCON)

<u>STEP</u>	<u>DESCRIPTION</u>	<u>NOTE</u>	<u>VERIFICATION</u>
		SS auto shutdown sequence starts here.	
12	13.	Turn on SS to start auto shutdown.	<u>MAN</u> <u>AUTO</u>
13	14.	Deactivate the FCV-301 Evaporator Salt Inlet Temperature Control by setting SP.301 at 0% and turning MAN.301 ON.	_____
15 18	15.	Disable the SGS operational Alarms by turning SAL off.	_____
04	16.	Turn off the boost pump and cold salt pump. Verify FCV-341 closed. N-90 will hold FCV-341 and FCV-301 closed if the Cold Salt Pump is not running.	_____
13	17.	Place/verify the following setpoints: SP.301           0% SP.341           0% SP.351           0%	_____
04	18.	Deactivate automatic control and close FCV-201.	_____
	19.	Close FCV-211, and verify ZSL 231 is on. Have TSS tech. manually lock FCV-211 closed.	_____
		<u>NOTE</u> The SS auto shutdown sequence stops here.	
12	20.	Verify/turn off CF.OFF if it was used. (Turns itself off when auto shutdown is complete).	_____
12	21.	Turn MAN.SDC and SDC ON. This <u>MUST</u> be accomplished to allow opening of the Salt Valves for drainage.	_____
	22.	Record sump levels and time prior to SGS drainback.  LT-201 Cold sump _____ , LT-221 Hot sump _____	_____
13	23.	Open the Cold Salt and Salt Drain Valves by setting the following controls and verify correct valve position. SP.301           100% SP.341           100% MAN.38182   On FCV-38182   On	_____
	24.	Wait 5 minutes from step 22 to allow drainage of salt to the Cold Sump prior to proceeding to step 21. Cold sump level should increase 6 to 10" during drainback.	_____

STEP	DESCRIPTION	VERIFICATION
12	25. Open the Hot Salt Valve by setting SP.351 to 100%. Verify the valve position and expect a hot sump level change of approximately 16 inches.	_____
12	26. Verify FCV-491 is closed in auto with a SP of 900 psi.	_____
	27. Fill the drum with Feedwater to a level of +15 inches by setting SP.411 to 20% and turning Man.411 ON. When the level has reached +15 inches, set SP.411 to 0%.	_____

NOTE

HRFS is no longer needed to support SGS and may be shutdown now if not separately required.

13	28. When no noticeable change in LT-201/LT-221 set controls to the following positions:	
	SP.341	0%
	SP.301	0%
	SP.351	0%
	FCV-38182	OFF

12	29. Turn SDC and MAN.SDC OFF.	_____
----	-------------------------------	-------

NOTE

If ambient temperature conditions either are or expected to be less than 32F°, assure that water side freeze protection circuits are operational and that no water/steam transmitter signals (particularly LT-311) are frozen prior to leaving the system unattended. If there is any indication that LT-311 may not provide a valid signal during unattended diurnal shutdown, due to freezing or any other reason, the circulation heater should be de-energized.

02	30. If FCV-151, FCV-161, and FCV-162 have not been manually locked closed during the SGS salt flow activity, an accumulation of salt will leak by and stagnate. Open FCV-151, FCV-161, and FCV-162 and allow the salt to drain.	_____
	31. Advise the SGS technician to complete the SGS posttest checklist (SOP #4) if no further SGS operation is planned, and the TSS posttest checklist (TOP #4) if no further TSS operation is on-going or planned.	_____

SGS IS NOW IN DIURNAL SHUTDOWN WITH THE SALT SYSTEM DRAINED.

NOTE

This procedure will not detail the steps to take the SGS from Diurnal Shutdown to the Empty Condition because it is not a planned part of the SGS testing. Refer to the SGS Manual Section 3.10 (Operating Procedures) for these detailed steps.

This Steam Generation operating procedure will be utilized to verify SGS integrity following all tests that use the SGS. It shall be performed by the SGS technician.

STEP	DESCRIPTION	CAUTION	VERIFICATION										
		Salt and water/steam temperatures will normally be maintained above 500°F. If repairs are required, a shut down to the Empty condition may be required.											
1.	Close the following isolation valves:												
	<table border="0"> <tr> <td>HV-481</td> <td>St. Deliv.</td> <td>HV-488</td> <td>Feedwater</td> </tr> <tr> <td>HV-487</td> <td>T-482</td> <td>HV-491</td> <td>T-481</td> </tr> </table>	HV-481	St. Deliv.	HV-488	Feedwater	HV-487	T-482	HV-491	T-481				
HV-481	St. Deliv.	HV-488	Feedwater										
HV-487	T-482	HV-491	T-481										
2.	Inspect the salt system for evidence of leaks and insulation damage. This is a general inspection for any condition that appears abnormal. If a problem is detected, a more thorough inspection will be required.												
	<ul style="list-style-type: none"> <li>o All SGS salt piping</li> <li>o Valves</li> <li>o Superheater and Evaporator</li> </ul>												
3.	Inspect the water/steam system for evidence of leaks and insulation damage. This is a general inspection for any condition that appears abnormal. If a problem is detected, a more thorough inspection will be required.												
	<table border="0"> <tr> <td>o SGS piping</td> <td>o Superheater</td> </tr> <tr> <td>o Valves, traps</td> <td>o Evaporator</td> </tr> <tr> <td>o BWCP</td> <td>o Steam Drum</td> </tr> <tr> <td>o Flange connections</td> <td>o Attemperator</td> </tr> <tr> <td>o Drain Plugs</td> <td>o Drain &amp; Blowdown Tank</td> </tr> </table>	o SGS piping	o Superheater	o Valves, traps	o Evaporator	o BWCP	o Steam Drum	o Flange connections	o Attemperator	o Drain Plugs	o Drain & Blowdown Tank		
o SGS piping	o Superheater												
o Valves, traps	o Evaporator												
o BWCP	o Steam Drum												
o Flange connections	o Attemperator												
o Drain Plugs	o Drain & Blowdown Tank												
4.	Check for visual evidence of blown fuses, burned relays or burned electrical components in the power junction box and generally throughout the SGS/TSS.												
5.	Verify with control room to switch and leave applicable heat tracing control to auto.												
6.	Verify operation of the SGS skid coolant pump and radiator.												
7.	Secure the boiler water sample station (HV-386).												
8.	Turn off/verify the chemical feed pump and close HV-387.												
9.	Note any abnormalities encountered during test activities.												
10.	Advise the Control Room that the SGS post test has been completed and the SGS is secure.												
11.	Complete the TSS post test checklist (TOP #4) if no further TSS operation is planned.												

This procedure will only be used for shutdown when the SGS and Propane Heater are in simultaneous operation. Due to the volume of salt that must be drained into the Cold Sump from the Propane Heater, salt will be bottled up in the SGS for approximately 20 minutes prior to drain. Perform steps 16 through 27 expeditiously.

STEP	DESCRIPTION	VERIFICATION
1.	Advise the TSS technician to adjust the Propane Heater stack temperature control to 600°F. Propane Heater salt outlet temperature (Acurex channel 142) will decrease over a period of time.	_____
13	<p>2. When steam demand has dropped to less than 3500 lbs/hr, switchover from SGS pressure control to flow control.</p> <p>a) Set SP.321 value to the same value as shown on ZT321.</p> <p>b) Activate the FCV 431 HRFS Steam Pressure Control (using PT-431) with a set point of 1100 psig.</p> <p>c) Deactivate the Steam Pressure Control by turning MAN.321 on.</p>	_____
3.	Close FCV 351 to 10% and open FCV 321 to 100% in the following steps: Set SP.351 to 50%, wait 5 seconds; then set SP.351 to 10%; after 5 seconds, set SP.321 to 50%; wait 5 seconds, then set SP.321 to 100%.	_____
4.	Open FCV 341; then close FCV 351 in series using the following incremental steps to decrease superheater inlet temperature (TE382). The operator will monitor TE382 to assure that TE382 does not decrease more than 100°F in any 6-minute period. Record start time.	_____
	<p>SP.341 to 10% for 1 minute</p> <p>" " to 20% for " "</p> <p>" " to 30% for " "</p> <p>" " to 40% for " "</p> <p>" " to 50% for " "</p> <p>" " to 60% for 1 minute</p> <p>" " to 70% for " "</p> <p>" " to 80% for " "</p> <p>" " to 90% for " "</p> <p>" " to 100% for " " ; maintain full open</p>	Time

SOP #5 SGS AND PROPANE HEATER SHUTDOWN

<u>STEP</u>	<u>DESCRIPTION</u>	<u>VERIFICATION</u>
	SP.351 to 6% for 1 minute	
	" " to 4% for 3 minutes	
	" " to 2% for 3 minutes	
	" " to 1.5% for 3 minutes	
	" " to 1% for 3 minutes	
	" " to 0.5% for 3 minutes	
	" " to 0% for 3 minutes; maintain closed	
04	5. Turn off the Hot Salt Pump. N90 will hold FCV351 closed if the Hot Salt Pump is not running.	
	6. Deactivate hot sump level control and close FCV 221. Verify closed.	
	7. Close FCV231. If sump level (LT-221) shows indication of leakage (slow rise), manually lock FCV231 closed.	
13	8. Deactivate the FCV331 Steam Delivery Temperature Control by setting SP.331 to 10% and turning MAN.331 On.	
13 14	9. Set FCV384 to ON (open) and verify the position on the micros.	
13	10. Set FCV383 to OFF (closed) and verify the position on the micros.	
	11. Verify MAN.EHAC ON. Turn EHAC off and then back on (pulse signal)	

SGS IS NOW IN WARM STANDBY

NOTE

To maintain the Warm Standby condition accomplish the following:

- a) Verify salt system temperatures (COP #1 Table A & B) are 480 F minimum.
- b) To maintain water/steam pressure at 1100 psig, reduce salt flow thru FCV341 to lowest compatible with stable flow (still maintaining PT-383 at 1100 psig).

Extended Warm Stdby

SOP #5    SGS AND PROPANE HEATER SHUTDOWN

---

<u>STEP</u>	<u>DESCRIPTION</u>	<u>VERIFICATION</u>
13	12. Deactivate the FCV-301 Evaporator Salt inlet temperature control by setting SP.301 at 0% and turning MAN.301 on.	_____
04	13. Deactivate cold sump level control and close FCV 201.	_____
	14. Close FCV 211 and manually lock it closed.	_____

CAUTION

The salt in the SGS will be bottled up until the cold salt valves are opened in Step 26. Do not delay in performing the following steps:

	15. Turn off the Cold Salt Pump and Boost Pump when the PT-180 pump outlet pressure drops below 150 psig (LT-201 approx. 11.5 in.) N90 interlock will close FCV 301 and FCV 341 - verify.	_____
05	16. Start Propane Heater drain by Opening FCV 241 to 100% open. Verify position.	_____

NOTE

There are two ways to deplete cold sump level after propane heater has been drained back to the cold sump. The best way is thru FCV-151, FCV-199, FCV-162 and back to the cold tank. The alternate way is to go thru SGS. Some if the following steps will have two parts; one for depleting the cold sump via FCV-151, or one for depleting cold sump via SGS.

	17. Place the FCV-151 handwheel in neutral. (This step isn't necessary if SGS will be used for depleting cold sump)	_____
	18. Continue to monitor LT-201. When it stabilizes at 55", close FCV 241 and manually lock it closed.	_____
04	19. Start the Cold Salt Pump and Boost Pump and verify PT-180 increases to greater than 170 psig.	_____
	20. Incrementally open FCV 151 to 40%.	_____

SOP #5 SGS AND PROPANE HEATER SHUTDOWN

<u>STEP</u>	<u>DESCRIPTION</u>	<u>VERIFICATION</u>
13	21. If SGS is used to deplete cold sump, Open FCV-301 and FCV-341.	_____
04	22. Turn off the Cold Salt Pump and Boost Pump when LT-201 reaches approx. 25".	_____
02	23. Close FCV 151, if used.	_____
	24. Turn MAN.SDC and SDC ON. This <u>MUST BE</u> accomplished to allow opening of the Salt Valves for drainage.	_____
13	25. Open the Salt and Salt Drain Valves by setting the following controls. Verify correct valve position.	_____
	MAN.301 On/SP.301 100%      MAN.38182 On MAN.341 On/SP.341 100%      FCV.38182 On	_____

NOTE

Monitor LT201 Cold Sump level during salt drainage. The level should increase by approx 6 inches.

- 26. Open the Hot Salt Valve by setting SP.351 to 100%. Verify the valve position and expect a hot sump level change of approximately 16 inches. Do not exceed 40" on LT-221. \_\_\_\_\_
- 27. Verify FCV491 is closed in auto with a SP of 1050 psi. \_\_\_\_\_
- 28. Fill the drum with Feedwater to a level of +15 inches, set SP.411 to 20% and turning MAN.411 ON. When the level has reached +15 inches, set SP.411 to 0%. \_\_\_\_\_

NOTE

HRFS is no longer needed to support SGS and may be shutdown now if not seperately required.

SOP #5 SGS AND PROPANE HEATER SHUTDOWN

<u>STEP</u>	<u>DESCRIPTION</u>	<u>VERIFICATION</u>
29.	Advise the TSS technician to complete TOP #3A Local Propane Heater Shutdown.	_____
13 02 05	30. Close the following valves as follows:  SP.341    0%       FCV 151    Closed SP.301    0%       FCV 162    Closed SP.351    0%       FCV 241    Closed FCV.38182 OFF    FCV 242    Closed	_____
31.	Lock the following valves closed:  FCV 301 FCV 341 FCV 241 FCV 242	_____
32.	Turn SDC and MAN.SDC OFF.	_____
<u>NOTE</u>		
If ambient temperature conditions either are or are expected to be less than 32 F, assure that water side freeze protection circuits are operational and that no water/steam transmitter signals (particularly LT-311) are frozen prior to leaving the system unattended. If there is any indication that LT-311 may not provide a valid signal during unattended diurnal shutdown, due to freezing or any other reason, the circ. heater should be deenergized.		
02	33. If FCV-151, FCV-161, & FCV-162 have not been manually locked closed during the SGS salt flow activity, an accumulation of salt will leak by and stagnate. Open FCV-151, 161, & 162 to allow the salt to drain.	_____
34.	Advise the TSS/SGS technicians to complete the SGS and TSS posttest checklists (SOP #4 & TOP #4) if no further TSS/SGS operation planned.	_____

SGS IS NOW IN DIURNAL SHUTDOWN WITH THE SALT SYSTEM DRAINED

NOTE

This procedure will not detail the steps to take the SGS from Diurnal Shutdown to the Empty Condition because it is not a planned part of the SGS testing. Refer to the SGS Manual Section 3.10 (Operating Procedures) for these detailed steps.



DIURNAL SHUTDOWN TO EMPTY CONDITION

Note

SGS will not have to be drained if ambient temperatures are above freezing.

1. Turn off the salt side heat trace, Ht.1-8.
2. Turn off the SGS circulation ht. 1-5. Wait until SGS is below 10 psi before continuing.
3. Open the following HV:
  - 485
  - 486
  - 487
  - 488
  - 489
  - 490
4. Open FCV-491, FCV-383
5. Let the system drain, when LT-311 is below -17 inches, do the following:
  - open HV-381/382/383
  - drain the SGS BWCP, the circulation heater, and adjacent piping.
6. Drain the following transmitters:
  - PT-383      FT-311      LT-311
  - PT-321      FT-381
  - PT-386      FT-411
7. After draining the water/steam transmitters, close the drain valves and isolation valves on the transmitters.
8. Drain the water sample line and the chemical feed station.
9. Assure the feedwater line is drained, but leave feedwater freeze protection on
10. Close all handvalves and drain plugs identified above.
11. Place SGS in the desired lay-up using an inert gas.

This Heat Rejection and Feedwater operating procedure will be utilized to verify HRFS integrity and establish its operation for all tests that use water/steam. The HRFS technician shall complete this checklist and coordinate HRFS start-up with the Control Room.

<u>STEP</u>	<u>DESCRIPTION</u>	<u>VERIFICATION</u>
1.	Inspect for evidence of leaks, insulation damage, or any condition that appears abnormal. If a problem is detected, a more through inspection will be required. Particularly check: <ul style="list-style-type: none"> <li>◦ D/D</li> <li>◦ SWHX</li> <li>◦ FWH</li> <li>◦ All Pumps</li> <li>◦ Valves</li> <li>◦ Piping</li> </ul>	_____
A. <u>Room 107</u>		
2.	Verify EPS cabinet 2 power is on.	_____
B. <u>East Donut - Tower Level 100'</u>		
3.	Verify that the following MCC motor controllers are enabled - circuit breakers closed and selector switches in the required control position - local, remote, or computer (preferred). <ul style="list-style-type: none"> <li>◦ CFP</li> <li>◦ CMUP</li> <li>◦ CWP</li> <li>◦ SWP</li> <li>◦ FWP</li> <li>◦ CF1 (4 fans ea.) thru CF6</li> </ul>	_____
4.	Turn the Tower Air Compressor on in continuous duty. Verify pneumatic air is available at 80 psig min. Note it may already be on for RS or Facility.	_____
5.	Turn off hydrazine pump (Left on overnight).	_____
6.	Complete the following to start the CFP - Cycle Fill Pump: <ul style="list-style-type: none"> <li>a. Start the CFP locally from the MCC - Motor Control Center. Verify outlet pressure is above 20 psi, and slowly open the discharge valve. Do not open discharge valve if pressure is low.</li> <li>b. Verify CFP not dead-headed and Demin. C. W. flow established thru Water Chemistry Table 2<sup>nd</sup> stage sample coolers by 30 GPM at FS-480 in rear of Water Chemistry Table.</li> </ul>	_____

<u>STEP</u>	<u>DESCRIPTION</u>	<u>VERIFICATION</u>
-------------	--------------------	---------------------

- |    |                                                                                                                                                                                                                                                                                                               |       |
|----|---------------------------------------------------------------------------------------------------------------------------------------------------------------------------------------------------------------------------------------------------------------------------------------------------------------|-------|
| 7. | Verify that the Demineralized Water Storage Tank is at least 80% full by LI-481 reading 96" minimum.                                                                                                                                                                                                          | _____ |
| a. | If make-up of demineralized water is needed, open the raw water handvalve and verify flow through FI-481 located at discharge of demin cartridges.                                                                                                                                                            | _____ |
| b. | If no flow is indicated, FCV-485 is closed. To open this valve, adjust conductivity meter CS-485 alarm level to 100%. Allow flow through the cartridges for 2 minutes, then readjust CS-485 alarm level to 30%. If the reading on CS-485 is above the 30% alarm level (6 mhos), have the cartridges replaced. | _____ |
| c. | If no make-up of demineralized water is needed, open the DI recirculating handvalve and circulate through the DI cartridges.                                                                                                                                                                                  | _____ |
| d. | Close raw water HV when makeup is not needed                                                                                                                                                                                                                                                                  | _____ |

8. Switch-over/Verify the 1500 GPM cooling loop is valved in and the 1 MW cooling loop is valved out by confirming the following valve positions:  
Ref. HOP #5 - HRFS cooling loop switching procedure.

NOTE

If these valves are not positioned properly, follow the order of HOP #5 to correct

<u>Outside East Door</u>		<u>NW Corner HRFS</u>		<u>Tower Chase</u>	
HV-400	Open/L	HV-411	Closed	HV-401	Closed
HV-440	Open/L	HV-420	Closed		
		HV-423	Closed		

- |    |                                                  |        |
|----|--------------------------------------------------|--------|
| 9. | Align/verify the following valve positions:      |        |
| a. | Tower Chase                                      |        |
|    | HV-501 Turbine Steam Isol.                       | Open   |
| b. | Spray Water Heat Exchanger                       |        |
|    | HV-450 SWHX Discharge                            | Open   |
|    | HV-451 SWHX Bypass                               | Open   |
| c. | Deaerator/Desuperheater                          |        |
|    | HV-410 FWH Return to D/D                         | Open   |
|    | HV-492 T-483 Isol.                               | Open   |
|    | HV-494 T-483 Isol.                               | Open   |
|    | FCV-483 D/D 1/4" Vent                            | Open   |
|    | FCV-484 D/D 1" Vent                              | Closed |
| d. | SGS - Coordinate positioning with SGS technician |        |
|    | HV-488 SGS Feedwater Inlet                       | Closed |
|    | HV-491 T-481 Isol.                               | Open   |

<u>STEP</u>	<u>DESCRIPTION</u>	<u>VERIFICATION</u>
10.	Confirm with the EMCON operator that he has set the following control devices in the listed positions per COP #1 Control Room pre-test check-list part VIII.	
	FCV 411 Man. closed	
	FCV 421 Auto open	
	FCV 431 Auto closed	
	FCV 432 Auto open (to bypass)	
	FCV 471 Auto closed	
	FY-472 Auto closed (CMUP stroke positioner)	
	FCV 491 Auto closed	
	D/D Htr N Off not enabled	
	D/D Htr S Off not enabled	

C. Donut Roof

- 11. Verify Wet Cooling Tower local disc. switch is on. \_\_\_\_\_
- 12. Ensure there is level in the Cooling Water Head Tank LI-402. Keep air out of system by venting air from HV-478, 433, 438, and 442 on the glycol cooling towers. There after these same valves should be vented again after every two hours of operation. \_\_\_\_\_
  - a. If there is no level, verify that C. W. has not drained into the C. W. Drain tank in the tower basement 50' level. \_\_\_\_\_
  - b. If level is low,
    - 1. Close HV-421 and bleed expansion tank to 0 psig.
    - 2. Start Glycol Booster Pump and add water until level is indicated on LI-402.
    - 3. Stop Glycol Booster Pump, close and lock HV-411. \_\_\_\_\_

D. CMUP Room - Tower Level 80'

- 13. Complete the following to start the CMUP - Condensate Make-up Pump:
  - a. Open the suction and discharge valves HV-453 & HV-461. \_\_\_\_\_
  - b. Adjust the accumulator stand pipe water level to mid-level or higher. \_\_\_\_\_
  - c. Start the CMUP. \_\_\_\_\_
  - d. Advise the Emcon operator to activate the FY-472 stroke positioner to maintain 15" D/D level (nominal) \_\_\_\_\_

HOP #1      HRF5 PRETEST CHECKLIST AND LOCAL START-UP

---

<u>STEP</u>	<u>DESCRIPTION</u>	<u>VERIFICATION</u>
14.	Request the D/D level read-out from the Emcon operator. If the level is low, determine if a 'fast fill' is required and/or possible (D/D press below 30 psig).	
	a. To conduct a 'fast fill' with the CFP:	
	1. Turn off the CMUP.	
	2. Close HV-453 in CMUP suction.	
	3. Open HV-402.	
	4. Close HV-448.	
	b. To stop the 'fast fill' and resume routine make-up with the CMUP when D/D level is sufficient, as monitored by the Emcon operator, perform the 4 steps of part a in reverse.	
15.	Verify the SWP local disc. switch is on (Ref. step 22).	
16.	Verify HV-456 and HV-452 are open.	
F.	<u>T-G Area - Tower Level 80'</u>	
17.	Determine from the Control Room what mode of FWP cooling is to be used.	
	a. For Wet Cooling Tower supplemental cooling, complete the following steps to start the CTP/CTF:	
	1. Verify HV-589 open.	
	2. Verify CTDI is full.	
	3. Verify CTP local disc. switch is on.	
	4. Determine T-G mode of operation.	
	5. Turn on CTP/CTF local starters.	
	6. Turn off FWP interlock by pass toggle switch.	
	7. Start CTP and CTF from T-G control location selected. Verify CTP starts acceptably.	
	8. Locally verify flow thru FI-584.	
	b. For domestic water cooling alone, turn on FWP interlock by pass toggle switch. (Mounted on CTP local starter)	
18.	Verify FCV-501 and Turbine Throttle Valve are closed by inspection.	

HOP #1 HRFS PRETEST CHECKLIST AND LOCAL START-UP

---

<u>STEP</u>	<u>DESCRIPTION</u>	<u>VERIFICATION</u>
G.	<u>Tower Level 60'</u>	
19.	Verify CWP local disc. switch is on.	_____
20.	Verify HV-415 and HV-419 are open.	_____
21.	Start CWP - Cooling Water Pump. Verify it starts acceptably.	_____
22.	Start SWP - Spray Water Pump. (Ref. steps 15 & 16).	_____
23.	Verify spray water flow at Emcon FT-482.	_____
24.	Complete the following steps to start the FWP - Feed Water Pump.	
	a. Verify correct valve alignment for cooling water mode selected. If wet cooling tower is used, the domestic cooling will also be needed.	
	1. Wet Cooling Tower	_____
	a. Open C.W. supply & return HV-577A & B.	
	2. Domestic cooling water	_____
	a. Open HV-517.	
	b. Verify hand valves on backflow preventers are open, should always be open.	
	c. Verify HV-518A and HV-518B are closed.	
	d. Open HV-519.	
	3. Domestic cooling water only	_____
	a. Close HV-577A and B.	
	b. Open HV-517, HV-518A and B, and HV-519.	
	c. Verify hand valves on backflow preventers are open, should always be open.	
	d. After cooling water has been valved in, verify flow through sight gages.	

<u>STEP</u>	<u>DESCRIPTION</u>	<u>VERIFICATION</u>
24.	FWP start-up (cont'd)	
	b. Conduct start-up.	
	1. Verify HV-465 and HV-471 are open.	_____
	2. Run oil charging pump (on FWP) for 2 minutes - verify TI-493 is above 170°F, oil is flowing and clean.	_____
	3. Advise Emcon operator to place FCV-401 in Auto. with a SP. of 1250 psi.	_____

NOTE

The FWP has a two stage starter with approx. 10 sec. delay between stages.

WARNING

Do not stand in FWP room during starting. Advise Control Room immediately if press. does not build up after second stage start or if any unusual noise is heard.

4.	Start FWP from Control Room and monitor discharge pressure. Confirm pressure stabilizes around 1250 psig.	_____
5.	Verify cooling water flow.	
	a. Wet Cooling Tower - Flow thru FI-484.	_____
	b. Domestic service water - cooling water discharge from drain.	_____

HOP #1 HRFS PRETEST CHECKLIST AND LOCAL START-UP

---

<u>STEP</u>	<u>DESCRIPTION</u>	<u>VERIFICATION</u>
G.	<u>East Donut - Tower Level 100'</u>	
25.	Verify glycol (CWP) flow thru Water Chemistry Table 1 <sup>st</sup> stage sample coolers by 35 - 40 GPM at FS-481 in rear of Water Chemistry Table.	_____
26.	Turn on the Dry Cooling Tower fans. List for repair any not operational.	_____
27.	Verify D/D Heater feeder circuit breakers and local disc's are closed.	_____
28.	Advise the Emcon operator that he may energize the D/D Heaters. If/when they are turned on, Advise him accordingly.	_____
29.	Conduct an HRFS water chemistry analysis every Monday. Advise the Control Room of unacceptable water quality. Ref. HOP #6 Water Chemistry Analysis.	_____
30.	As required, inject Hydrazine into the HRFS by locally turning on the Hydrazine Feed Pump. Advise the Control Room of HFP operation. (Normally to be on overnight, off during day)	_____
31.	Advise the Control Room that the HRFS pretest checklist and local start-up is complete.	_____

HRFS IS OPERATIONAL



This Heat Rejection and Feedwater operating procedure shall be completed by the Emcon operator in conjunction with local start-up by the HRFS technician.  
FOLLOW THE HRFS TECHNICIANS DIRECTION.

<u>STEP</u>	<u>DESCRIPTION</u>	<u>VERIFICATION</u>
1.	Verify CFP is on by ZSHCFP on.	_____
2.	Start CMUP when requested. Verify ZSHCMUP on.	_____
3.	Set FY-472 CMUP stroke positioner in Auto SP 15".	_____
4.	Advise technician of the D/D level LT-471. If level is significantly below requirements and pressure PT-432 is below 30 psig, Advise the technician to initiate a 'fast fill' of the D/D by valving out the CMUP and using the CFP alone. Monitor D/D level - When adequate level is attained, advise the tech to terminate the 'fast fill' and resume normal CMUP operation.	_____
5.	Advise technician of FWP cooling mode (Wet Cooling Tower or Domestic water) and T-G control mode desired (local/remote).	_____
6.	If Wet Cooling Tower FWP cooling is to be used, Verify correct T-G TCPMS control mode selection (Off- local, On - remote) and Start CTP and CTF as directed. Verify ZSH's on.	_____
7.	Start CWP as directed. Verify ZSH on and remote panel On light lit.	_____
8.	Start SWP. Verify ZSH on and remote panel On light lit. Verify FT-482 flow indication (approx 150K#/hr) and advise technician.	_____
9.	Verify FCV-432 Auto SP is 233 psi and open to Bypass SWHX cooling.	_____
10.	Enable D/D Heaters by doing the following: a. Turn on EH1, and EH2 b. Verify/Activate H1, and H2 with a SP. of 390°F.	_____

HOP #2 HRFS START-UP

<u>STEP</u>	<u>DESCRIPTION</u>	<u>VERIFICATION</u>
11.	Complete the following steps to start the FWP:	
	A. Verify/Close FCV-411; (Emcon MAN.411 On. SP.411 Auto 0%). Verify at Net 90.	_____
	B. Set FCV-401 to Manual 38% open.	_____
	C. Verify with technician that cooling water is being supplied to the pump.	
	D. Start FWP. Note the FWP has a two stage starter with approx. 10 sec. delay between stages (and remote panel light indication).	_____
	<u>CAUTION</u>	
	Verify FWP discharge pressure quickly builds, reaches, and stabilizes near 1250 psig.	
	E. Verify ZSHFWP on, remote panel On light lit, and PT-401 increasing to 1250 psig.	_____
	F. Activate FCV-401 with a SP of 1250 psig.	_____
12.	Turn on Dry Cooling Tower Fan groups CF1 thru CF6. Verify ZSHCF1 thru 6 are On.	_____
13.	Confirm HRFS pretest checklist and local start-up is complete when so advised by the HRFS technician.	_____
14.	Activate the following operational alarms:	_____
	PT-401 LT-471	
15.	Complete SGS Drum level make-up as required per COP #1 Control Room pretest checklist part VII.	

NOTE

D/D Temp. should start to rise within 15 minutes. If the system temp. is not rising check FCV-432, and D/D heaters for proper operation.

This Heat Rejection and Feedwater operating procedure shall be performed by the Emcon operator. Advise the HRFS technician of Pump/Fan/Heater Shut-off.

<u>STEP</u>	<u>DESCRIPTION</u>	<u>VERIFICATION</u>
1.	Verify SGS Steam Drum is filled adequately to compensate for Diurnal Shutdown water losses. Ref. COP #1 Control Room pretest checklist part VII for procedure.	_____
<u>NOTE</u>		
Motor shutdown location should coincide with the startup location.		
2.	Deactivate operational alarms: PT-401 LT-471	_____
3.	Disable D/D Heaters by turning off EH1, & EH2. This turns the heaters off and the HRFS tech. verifies they're off in his post test checklist.	_____
4.	Verify FCV-432 is open to bypass SWHX.	_____
5.	Turn off the FWP. Verify PT-401 pressure drops. Allow cooling water to continue for 30 minutes after FWP has been shut down.	_____
6.	Turn off the SWP. Verify FT-482 flow drops.	_____
7.	Turn off the CWP.	_____
8.	Turn off the Dry Cooling Tower fans.	_____
9.	Set FCV-471 Auto SP to 0% (close valve).	_____
10.	Set CMUP stroke positioner FY-472 Auto SP to 0% (closed).	_____
11.	Turn off CMUP.	_____
12.	If used for FWP cooling and EPGS pumps are not operating, Turn off CTP and CTF. Allow 30 min. after FWP has been shut down.	_____
13.	Advise the HRFS technician to complete the HRFS post test checklist (HOP #4).	_____

HOP #4 HRFS POST TEST CHECKLIST

Test Date  
9/22/84

This Heat Rejection and Feedwater operating procedure will be utilized to verify HRFS integrity following all tests that use the HRFS. This checklist shall be completed by the HRFS technician. \*STRICTLY LOCAL.

<u>STEP</u>	<u>DESCRIPTION</u>	<u>VERIFICATION</u>
1.	*Inspect HRFS for leaks or other abnormalities.	_____
2.	*Turn on Hydrazine Feed Pump if needed.	_____
3.	*Verify D/D Heater contactors are off.	_____
4.	*Close D/D vent FCV-483.	_____
5.	Verify/Turn off FWP, SWP, CWP.	_____
6.	Verify/Turn off Dry Cooling Tower Fans.	_____
7.	Verify/Turn off CMUP and accumulator air.	_____
8.	If used for FWP cooling and EPGS pumps are off, Verify/Turn off CTP and CTF, 30 minutes after FWP has been shut down.	_____
9.	*Turn off CFP and close the discharge valve.	_____
10.	*Turn off the Tower Air Compressor only after obtaining clearance from Control Room. (It may still be in use for RS or Facility).	_____
11.	Advise Control Room that HRFS post test is complete and HRFS secured.	_____

NOTE

If the HRFS is to be shutdown for a period of time, the high pressure steam line should be drained and blenketed with nitrogen. Nitrogen can be piped in at the 140 foot level through HV-468.

A. Glycol System Cooling

<u>STEP</u>	<u>DESCRIPTION</u>	<u>VERIFICATION</u>
-------------	--------------------	---------------------

1. 1500 GPM Cooling Loop to 1 MW Cooling Loop Switching Procedure

CAUTION: Steps must be performed in the order they are written! To do otherwise may result in serious damage to system components.

- a. Confirm that the 1500 GPM Cooling water pump is off and turn off disconnect in the sub-basement. \_\_\_\_\_
- b. Close HV-440 and HV-400 and lock out - located outside the east door to HRFS. \_\_\_\_\_
- c. With HRFS compressor switch in continuous run position, set pressure to 85 psig in expansion tank using ball valve HV-416 at top of tank. (Return compressor switch to off unless needed specifically for experiment.) \_\_\_\_\_
- d. Open HV-423 and HV-411 and HV-420 - located in the NW corner of HRFS. \_\_\_\_\_
- e. Open HV-401 located in east chase, level 100. \_\_\_\_\_
- f. Turn on disconnect to 1 MW pump in HRFS. \_\_\_\_\_

The 1 MW Cooling loop is now ready for operation. To provide cooling for the Working Receiver loop:

- a. Request 1 MW pump be turned on from control room Confirm it is operational. \_\_\_\_\_
- b. Turn on cooling towers from HRFS. \_\_\_\_\_

When cooling requirements are no longer needed, follow the procedure below:

2. 1 MW Cooling Loop to 1500 GPM Cooling Loop Switching Procedure

CAUTION: Again these steps must be performed in order!

- a. Request control room to turn off 1 MW Pump. Turn off disconnect and lock out. \_\_\_\_\_
- b. CLOSE HV-401 and lock out - located in east chase, level 100. \_\_\_\_\_
- c. CLOSE HV-411, HV-423, and HV-420 and lock out - located in NW corner of HRFS. \_\_\_\_\_

HOP #5 HRFS COOLING LOOP SWITCHING PROCEDURES

---

A. Glycol System Cooling (cont'd)

<u>STEP</u>	<u>DESCRIPTION</u>	<u>VERIFICATION</u>
d.	OPEN vents on cooling towers, HV-428, HV-433, HV-438, and bleed off air.	_____
e.	OPEN HV-400 and HV-440 and lock out - located outside east door to HRFS.	_____
f.	OPEN and bleed air through HV-412, HV-442, near spray water heat exchanger.	_____
g.	Shut off cooling towers from HRFS.	_____
h.	Turn on disconnect to 1500 GPM cooling water pump in sub-basement.	_____

1500 GPM Cooling Loop is now ready to operate according to the HRFS operating procedures.

HOP #5 HRFS COOLING LOOP SWITCHING PROCEDURES

---

B. FWP Cooling Water

<u>STEP</u>	<u>DESCRIPTION</u>	<u>VERIFICATION</u>
1.	Wet Cooling Tower	
a.	Close Cooling Tower service water valve.	_____
b.	Close HV-517 and HV-518 on line to FWP Drain.	_____
c.	Open cooling water supply and return HV-577A and HV-577B.	_____
d.	Verify HV-589 is open (CTP suction valve).	_____
e.	Verify Cooling Tower Drain Tank (CTDT) is full, open HV-590 and fill if needed.	_____
f.	Turn on Cooling Tower fan disconnect switch, located on top of East donut. This step can be accomplished when checking LI-402.	_____
g.	Determine Turbine-Generator mode of operation. Local (TCP) or remote (EMCON) and place selector accordingly.	_____
h.	Turn on CTP/CTF Local Starter, located by the turbine, fan will need to be run to keep TI-588 or TT-582 below 100°F.	_____
i.	Start CTP/CTF, either from TCP or from the EMCON.	_____
j.	Verify flow through FI-584.	_____

The Wet Cooling Tower is running and ready to deliver cooling water to FWP

NOTE

Once FWP is operating, verify cooling water flow through FI-484 located at FWP.

2.	Domestic Cooling Water	
a.	Close HV-577A and HV-577B.	_____
b.	Open HV-517 and HV-518 on FWP drain line.	_____
c.	Verify hand valves on backflow preventor are open, should always be open.	_____

Domestic cooling water is valved in and ready to supply cooling water to FWP

NOTE

Once FWP is operating, verify cooling water is being discharged to the drain.

Water chemistry analysis shall be performed at least once a day.

<u>STEP</u>	<u>DESCRIPTION</u>	<u>VERIFICATION</u>
-------------	--------------------	---------------------

NOTE

All HRFS water samples should be taken from the water chemistry table in the HRFS. Use the following sample lines:

- #3 - High Pressure Steam Line
- #4 - Effluent of Deaerator
- #5 - Feedwater Line to SGS

A. Operation of Water Chemistry Table:

1. Open the 10 sample inlet lines located in the back of the water chemistry table. \_\_\_\_\_
  
2. Open the following sample lines located on the front panel of the water chemistry table:
  - #3 - only for analysis of steam from SGS
  - #4 - analysis of HRFS
  - #5 - analysis of feedwater\_\_\_\_\_
  
3. After samples are taken, close the 10 inlet valves. \_\_\_\_\_

B. Sampling Operations After HRFS is in Operation:

1. For determination of deaerator water quality, use sample line #4. \_\_\_\_\_
  
2. For feedwater quality, use sample line # 4 or #5. \_\_\_\_\_
  
3. For steam quality, SGS must be providing steam to the deaerator. Use sample line #3. \_\_\_\_\_

NOTE

Results of the water chemistry analysis will be compared to the Water Conditioning Table provided on the next page. Record all results in the HRFS water chemistry log.



WATER CONDITIONING TABLE

<u>Parameter</u>	<u>SGS</u>	<u>Deaerator/Feedwater/Hotwell</u>
pH	9.5 - 10.5	8.0 - 9.5
Hydrazine	100 -200 ppb	200-300 ppb (.2-.3mg/l)
Iron	Max 500 ppb	Max 500 ppb
Conductivity	Max 30 umho	Max 30 umho
Phosphate	10 - 40 ppm	---
Dissolved Solids	Max 100 ppm(mg/l)	---
Silica	(A) Max 200 ppb	(B) Max 20 ppb
Chloride	(A) Max 10 ppm	(B) Max 2 mg/l
Hardness		(B) 0.0 mg/l

(A) Test required only on Mondays or as the need would indicate.

(B) These tests only need to be run when there is a problem with the demineralizers.

C. Chemical Analysis Procedure

PH Analysis (Hach Portable Colorimeter + Ph Electrode)

1. Connect Ph electrode to colorimeter. \_\_\_\_\_
2. Insert Ph card in colorimeter. \_\_\_\_\_
3. Place electrode in Ph buffer and calibrate colorimeter to buffer Ph by pressing the Ph switch. Adjust the colorimeter to the buffer Ph of 7 by using the standardize control knob. \_\_\_\_\_
4. Insert Ph electrode in sample and read Ph value. \_\_\_\_\_
5. Rinse Ph electrode with demin. water and store in its container. \_\_\_\_\_
6. Keep probe in vial to protect electrode. \_\_\_\_\_

Conductivity (Markson Conductivity Meter)

1. Place conductivity cell into the water sample. \_\_\_\_\_
2. Switch meter to read conductivity. \_\_\_\_\_
3. Adjust scale to read between 1 and 10. Multiply reading by the factor scale. This is the conductivity reading. \_\_\_\_\_

Iron (Hach Portable Colorimeter)

1. Fill sample bottle with 25 ml of sample water. Add one-half vial of sulfur and let sit for a minimum of 5 minutes. \_\_\_\_\_
2. Fill another sample bottle with 25 ml of demin. water. \_\_\_\_\_
3. Insert ferrozine card in colorimeter and adjust dial to 550 NM. \_\_\_\_\_
4. Calibrate meter by pressing colorimeter and adjusting to infinity mark with zero adjustment. \_\_\_\_\_
5. Press off button. \_\_\_\_\_
6. Insert demin. sample in colorimeter, rough side of sample bottles facing left and right. Close cover and press colorimeter and test button. Adjust zero reading using light control dial. \_\_\_\_\_
7. Press off button. \_\_\_\_\_
8. Insert water sample in colorimeter, press colorimeter and test button. The reading should be multiplied by 1000. This will be PPb. \_\_\_\_\_
9. Clean out sample bottle with demin. water. \_\_\_\_\_

Hydrazine (Hach Portable Colorimeter)

1. Fill sample bottle with 25 ml of demin. water. Add 1 ml of Hydrazine Reagent. \_\_\_\_\_
2. Fill another sample bottle with 25 ml of the sample water. Add 1 ml of Hydrazine Reagent and let sit for 12 to 20 minutes. \_\_\_\_\_
3. Insert hydrazine card in colorimeter and adjust dial to 450 NM. \_\_\_\_\_
4. With cover closed, push colorimeter button and adjust to infinity mark using the zero adjustment. \_\_\_\_\_
5. Insert demin. water sample with rough sides facing left to right in colorimeter, enable colorimeter button, press test button and adjust zero reading using light control dial. \_\_\_\_\_
6. Press off button. \_\_\_\_\_
7. Insert sample water in colorimeter. Close lid, push colorimeter button and hold the test button. The reading should be multiplied by 1000. This will be PPb. \_\_\_\_\_
8. Clean out sample bottle with demin. water. \_\_\_\_\_

Phosphate (Hach Portable Colorimeter)

1. Fill a sample bottle with 25 ml of sample water. \_\_\_\_\_
2. Add 1 ml of Molybdate Reagent and mix. Then add 1 ml Amino Acid Reagent and mix. Allow to sit for 10 minutes. \_\_\_\_\_
3. Insert the phosphate (Amino Acid Methol) card in colorimeter and adjust dial to 525 NM. \_\_\_\_\_
4. Press the colorimeter switch and adjust the needle to infinity with the zero adjust control. \_\_\_\_\_
5. Fill a second sample with 25 ml of sample water only and place in colorimeter. \_\_\_\_\_
6. Close lid and push test button. Adjust the needle to zero with the light control. Turn off colorimeter. \_\_\_\_\_
7. Place the prepared sample (Molybdate and Amino Acid added) into the colorimeter and hold down the test button. This value is PPM. \_\_\_\_\_
8. Rinse both sample bottles with demin. water. \_\_\_\_\_

HOP # 6 HRFS WATER CHEMISTRY ANALYSIS

---

Total Dissolved Solids (Chemtrix TDS-1)

1. Fill sample reservoir on TDS-1 with sample water. \_\_\_\_\_
2. Wait 10 to 15 seconds, then press 1000 PPM button. If there is no major movement, depress lower ppm buttons until value is read. \_\_\_\_\_
3. Dump out sample water and rinse with demin. water. \_\_\_\_\_

CAUTION

Avoid getting meter wet as it is not waterproof

Silica (0-3 PPM) (Hach Portable Colorimeter)

1. Fill sample bottle with 25 ml of sample water. Add contents of one Molybdate Reagent Pillow (for Silica). Add contents of one Acid Reagent powder Pillow (for Silica). Let sample stand for 10 minutes. \_\_\_\_\_
2. Add contents of one Citric Acid Pillow and mix. Allow to stand for 2 minutes. Then add contents of one Amino Acid Reagent Pillow and mix. A blue color will appear if silica exists. Wait 5 minutes for color to fully develop. \_\_\_\_\_
3. Insert the silica (Heteropoly Blue Method) meter scale into the colorimeter and adjust dial to 610 NM. \_\_\_\_\_
4. Close lid on colorimeter. Press colorimeter switch and adjust needle to infinity using zero adjustment knob. Turn off colorimeter. \_\_\_\_\_
5. Fill a sample bottle with 25 ml of sample water and place in colorimeter. Close the light shield and hold test switch and adjust needle to zero using light control knob. \_\_\_\_\_
6. Place prepared sample in colorimeter. Close lid and press test button. Value read is to be multiplied by 1000. this is PPb. \_\_\_\_\_

Chloride (Hach Digital Titrator)

1. Select a .2243 silver nitrate cartridge and install on the end of the titrator by rotating the cartridge 1/4 turn. \_\_\_\_\_
2. Remove vinyl cap from the end of the cartridge and insert red deliver tube into end of cartridge. Do not insert tube past inside end of cartridge. Make sure no burrs are on leading edge of tube. \_\_\_\_\_
3. Turn the course delivery knob until several drops of solution flow from the delivery tube. Reset the digital counter to zero and wipe the tip. \_\_\_\_\_
4. Fill a erlenmeyer flask with 50 ml of sample water. \_\_\_\_\_

HOP #6 HRFS WATER CHEMISTRY ANALYSIS

---

Chloride cont'd

5. Add contents of one chloride II mix. The color should be yellow. \_\_\_\_\_
6. Titrate the sample while swirling the flask until the color changes to red-brown. \_\_\_\_\_
7. Read the number of digits from the digital counter window. Divide the value by 10 to get PPM. \_\_\_\_\_
8. Rinse the erlenmeyer flask with demin. water after use. \_\_\_\_\_

This electric Power generation operating procedure will be utilized to verify EPGs integrity prior to all tests that use the EPGs. This checklist shall be completed by the EPGs technician.

<u>STEP</u>	<u>DESCRIPTION</u>	<u>VERIFICATION</u>
-------------	--------------------	---------------------

NOTE 1. Be advised that these valve positions are verified correct in HRFS check-lists:

HV-501	Main Steam Isolation (Open)
HV-577A & B	FWP Cooling Water (As Req'd)
FCV-471	Condensate Return (Closed from EMCON)

NOTE 2. Inspect for evidence of water and oil leaks or other abnormalities as you complete this checklist. (Verify none found in Step 34).

A. Condenser Platform - 60' Level

1. These valves remain closed. \_\_\_\_\_  
Check only if you suspect they have been opened.  
If CWP is on, bleed air from waterbox by venting.
  - a. HV-593 Condenser inlet waterbox vent
  - b. HV-594 Condenser inlet waterbox drain
  - c. HV-597 Condenser blind waterbox drain
  - d. HV-598 Condenser blind waterbox vent
2. Verify these valves are open: \_\_\_\_\_
  - a. HV-584 Hotwell outlet/CNP suction
  - b. HV-581 CNP discharge
  - c. HV-582 CNP discharge orifice recirculation
  - d. HV-583 Condenser vacuum exhaust isolation
  - e. HV-586 Turbine steam seal exhaust isolation (1 turn open)
3. Record hotwell level from sight glass LI-581, leave isolation HV-595 & 596 open. Lvl. \_\_\_\_\_"

B. 60' Level

4. Verify these valves are open: \_\_\_\_\_
  - a. HV-578 AEP separator tank make-up
  - b. HV-588A AEP cooler cooling water supply
  - c. HV-588B AEP cooler cooling water return
5. Verify AEP separator tank level is between 4 & 6" at sight glass LI-583 (auto LV-581 M-U) \_\_\_\_\_
6. Verify CNP and AEP local disconnect switches are closed. \_\_\_\_\_

POP #1 EPGS PRETEST CHECKLIST

STEP	DESCRIPTION	VERIFICATION
C.	<u>Control Area - 80' Level</u>	
7.	Verify EPGS UPS has 2 Green lights on.	_____
8.	Turn on exciter cabinets vent fans with switch on side of VRP. Verify vent fan operation at VRP, rectifier cabinet, resistor cabinet, and at isolation transformer enclosure (L4 Bkr. 12).	_____
9.	Verify generator breaker is racked in, charged, and open.	_____
10.	Verify electrical power is (always) on:	_____
	<ul style="list-style-type: none"> <li>a. TCP - Timer display on (L4 bkr 9)</li> <li>b. GCP - Generator Breaker green light on (L4 bkr 15)</li> <li>c. Generator heater - Local starter on/TCP sw in Auto</li> <li>d. Oil heater - Local starter on/TCP sw in Auto</li> </ul>	
11.	Close TCP sw.'s for FCV-501, 511, 512, 541, & 551 Place EOP selector switch in the 'HAND' position.	_____
12.	Determine where the EPGS will be operated from - 'local' at T-G or 'remote' at Emcon Console. Reposition mode select switch, if required, in the next step.	_____
13.	Determine if CTP is operating for HRFS/FWP (TCP red light) <ul style="list-style-type: none"> <li>a. CTP off - Position TCP mode select switch in the control mode determined in Step 12.</li> <li>b. CTP on - Verify TCP mode select sitch is positioned in agreement with Step 12. Correct switch position, if necessary, only with Emcon operator permission (to avoid FWP trip).</li> </ul>	Local    Remote _____ CTP off _____ CTP on _____
14.	Turn on all local starters except Exciter disc., 8 total, and verify 5 TCP indicating lights on.	_____
15.	Verify compressed air is available and controls functional by stroking FCV-521 from oper. mode cont'l location. Verify local air venting or valve motion and Emcon ZT-521 operation. Close FCV-521 and confirm after function check.	_____
16.	Assure turbine oil temperature is above 60°F. Conduct POP #1A Part A - Turbine oil temp. ck., if necessary, to determine oil temperature and/or warm oil.	_____

<u>STEP</u>	<u>DESCRIPTION</u>	<u>VERIFICATION</u>
D.	<u>T-G Platform - 80' Level</u>	
17.	Verify HV-592 steam line drain valve is closed.	_____
18.	Verify these valves are open:	_____
	a. HV-575      Steam line trap	
	b. HV-576      Steam seal (1/4 turn open)	
	c. HV-587      Generator cooling water supply	
	d. HV-521      Lube oil cooler oil diverting (open to cool.)	
	e. HV-574      Throttle Valve trap	
19.	Verify OST mechanism is reset.	_____
20.	Verify Throttle Valve is reset closed by inspection - no un-threaded rod showing on cylinder screw.	_____
21.	Verify FCV-501 is closed by inspection.	_____
22.	Verify EOP local disconnect switch is closed.	_____
23.	Verify turbine oil reservoir level is 2 1/2", + 1/2", above normal operating level mark at dipstick LI-582; or if EOP is on for oil heating, verify dipstick LI-582 normal operating level is maintained.	_____
24.	Verify excitor bearing oil reservoir is full by removing wing-nut reservoir plug & inspecting.	_____
25.	Verify duplex oil strainers are operational. Alternate strainer selection weekly.	_____
E.	<u>Tank Area - 80' Level</u>	
26.	Verify CTP local disconnect switch is closed.	_____
27.	These valves remain closed. Check only if you suspect they have been opened.	_____
	a. HV-580      CNST drain	
	b. HV-590      CTDT make-up	
	c. HV-591      CTDT drain	
	d. HV-599      CNST make-up isolation	
28.	Open these valves:	_____
	a. HV-579      Hotwell make-up	
	b. HV-585      Hotwell dump	
	c. HV-589      CTP suction	_____



POP #1 EPGs PRETEST CHECKLIST

---

STEP	DESCRIPTION	VERIFICATION
29.	Verify CTDt is full by overflow when M-U water is added thru HV-590; or if CTP is on for HRFS/FPW, verify CTDt maintains normal operating level of 18" between 16 and 20" at sight glass LI-585.	_____
30.	Assure hotwell water quality is acceptable. Conduct (HRFS) water chemistry analysis as necessary to insure iron is less than 500 ppb. Record, if measured. Drain and refill hotwell if required to correct, Ref. POP #1A Parts B & C.	_____
31.	Verify hotwell and CNST levels are correct. Conduct POP #1A Parts B & C, Hotwell and CNST level adjustment, if necessary, to correct.	ppb. Iron
	a. Hotwell level 12" (betw. 9 & 14") at condenser sight glass LI-581, initially recorded in Step 3.	_____
	b. CNST level between 12 & 30" at tank sight glass LI-584.	_____
	c. Verify agreement between TCP meter LT-511 and LI-581 sight glass hotwell level.	_____
F. <u>CMUP Room - 80' Level</u>		
32.	Verify FCV-471 is closed by inspection.	_____
33.	Open HV-406 condensate return to HRFS.	_____
34.	Verify no water or oil leaks or other abnormalities found.	_____
35.	Advise control room that EPGs Pre-test checklist has been completed. (Turbine oil temperature & hotwell are okay).	_____

"EPGS PRE-TEST CHECKLIST COMPLETE"

<u>STEP</u>	<u>DESCRIPTION</u>	<u>VERIFICATION</u>
A.	Turbine Oil Temperature Check, as Required. Reference EPGS Pretest Checklist Step 16.	
1.	Complete pretest checklist (Steps 10,14)	_____
2.	Verify Turbine oil reservoir level is 2 1/2" + 1/2" above normal operating level mark at dipstick LI-582	_____
3.	Verify EOP local disconnect switch is on.	_____
4.	Conduct the following operations from the control location selected at the TCP mode select switch (TCPMS).	Local Remote
5.	Start EOP.	_____
6.	Verify PT-501 oil pressure increases above 6 psi.	_____
7.	Wait 1 minute, then check TT-521 oil temperature. If desired, confirm locally at TI-586.	_____
8.	Check is complete if TT-521 oil temperature is above 70°F. Turn off EOP.	_____
9.	If TT-521 oil temperature is below 70°F, leave on EOP and oil heater until temperature increases above 70°F, then turn off EOP.	_____
<u>NOTE</u>		
Pre-test checks may be continued during oil heating.		
10.	Note in remote Emcon control, the oil heater auto control may be overridden and the heater forced on, if desired, by enabling 'OH.ON'.	Enable OH.ON
11.	Disable OH.ON and return heater control to auto after oil is warm.	Disable OH.ON

<u>STEP</u>	<u>DESCRIPTION</u>	<u>VERIFICATION</u>
B.	<u>Hotwell Level Adjust, as Required</u>	
1.	Complete pretest checklist (Steps 1 - 30)	_____
2.	Transfer record of hotwell level here from POP #1 EPGS Pretest checklist Step 3.	<u>Lvl.       "</u>
3.	Verify remote Emcon EN.HLC auto hotwell level control is off.	_____
4.	Make up Hotwell if less than 9"	_____
	a. Attempt to determine cause of level loss (leaky pipes, improperly opened valves, shutdown). Correct as required.	
	b. From TCP control location selected, open make-up FCV-512.	
	c. Fill till hotwell level sight glass LI-581 is 12".	
	d. If CNST did not have enough water to complete fill, close FCV-512, conduct CNST make-up (POP #1A Part C), then resume fill.	
	e. Close FCV-512.	
5.	Dump Hotwell if above 14".	_____
	a. Attempt to determine cause of level increase (improperly opened valves). Correct as required.	
	b. Start CNP.	
	c. Open FCV-511.	
	d. Dump till hotwell level sight glass LT-581 is 12"	
	e. Close FCV-511.	
	f. Stop CNP.	
6.	Alternate dump if above 14" or to correct water quality (wastes condensate). Open CNP inlet strainer S-581 HV till LI-581 is 12", or if draining, Zero".	_____
7.	Verify agreement between LT-511 TCP meter and LI-581 sight glass hotwell level. Record level as left.	<u>Lvl.       "</u>

<u>STEP</u>	<u>DESCRIPTION</u>	<u>VERIFICATION</u>
C.	<u>CNST Level Adjustment</u> , as Required	
1.	Verify CNST level is between 12 and 30" at sight glass LI-584.	_____
2.	Dump if above 30" by draining through HV-580 into floor drain. The preferred dump is into the hotwell (POP #1A Part B, Step 4), but it is assumed here that the hotwell level is already properly adjusted.	_____
3.	Fill if lower than 12".	_____

NOTE

This fill procedure will deplete the CMUP stand pipe. If CMUP is operating, do not allow this to happen by reducing the stand pipe air overpressure, either by relief valve manual blow-off or regulator adjustment.

- a. Verify HRFS/Cycle Fill Pump is on.
- b. Open CNST M-U FCV-541 with TCP switch.
- c. Open M-U HV-599.
- d. When filled, close HV-599 and FCV-541.
- e. Readjust CMUP stand pipe level.

NOTE

Hydrazine can be added to the CNST as determined from a Water Quality Analysis by filling a beaker at the HRFS Hydrazine Feed Tank drain and pouring it into the CNST LS-541 flange opening.

<u>STEP</u>	<u>DESCRIPTION</u>	<u>VERIFICATION</u>
A.	<u>EPGS PUMP S/U</u>	
1.	Verify: <ul style="list-style-type: none"> <li>◦ Flashlight as available to check bearing oil flow.</li> <li>◦ Synch sw. handle has been procured as required.</li> <li>◦ POP #1 EPGS Pretest Checklist is complete.</li> <li>◦ EPGS control is in local (Do not disrupt CNP oper.).</li> </ul>	_____
2.	Start CTP, if not already on. Verify on.	_____
3.	Start CTF if ambient temp. is above freezing. Verify.	_____
4.	Confirm LT-511 hotwell level is 12" (or between 9 & 14").	_____
5.	Open FCV-551 for CNP recirculation.	_____
6.	Start CNP. Verify on, LT-511 hotwell level will drop 1". Note EPS will lock this out upon prior SGS BCP shutdown. Advise the Emcon operator to reset EPS 3 and 2 to clear.	_____
7.	Start AEP. Verify on, PT-502 condenser pressure should decrease to less than 15" Hg.	_____
8.	Confirm oil cooling FCV-521 closed (Emcon ZT-521).	_____
9.	Place EOP select. sw. in auto. To start EOP. Verify on. PT-501 oil bearing pressure should increase above 10 psi.	_____
10.	Wait 1 minute, then verify TT-521 oil temperature is above 60°F.	_____
11.	Reset Emerg. trip ETR (FCV-561) and verify PT-531 Hydraulic oil pressure is above 50 psig.	_____

'EPGS PUMPS ON'

<u>STEP</u>	<u>DESCRIPTION</u>	<u>VERIFICATION</u>
<u>B. T-G SET-UP</u>		
1.	Verify from Emcon operator that condenser cooling water temp. TE-486 is below 100°F.	_____
2.	Verify <u>SGS</u> steam production from Emcon operator.	_____
	a. PT-431 Steam pressure above 1000 psi	_____
	b. TE-483 Steam temperature above 600°F and rising	_____
3.	Verify from Emcon operator that SGS is in manual salt flow control (5 klb/hr min. steam flow) and FCV-431 is controlling steam pressure.	_____
4.	Advise the Emcon operator to transfer primary D/D level control from CMUP to CNP by activating FCV-471 with a SP of 15" and resetting the SP of FY-472 to 14".	_____
5.	Close CNP recirc. FCV-551.	_____
6.	Verify <u>EPGS</u> turbine start-up readiness	
	a. (sight windows) FI-501 & 502 brg. oil flow	
	b. TT-521 oil temperature above 60°F	
	c. PT-501 brg. oil press above 8 psig	
	d. PT-502 condenser vacuum below 15" Hg.	
	e. LT-511 hotwell level at 12" (betw 9 & 14")	
	f. PT-531 hydraulic oil press above 50 psig	_____
7.	Drain steam pipe condensate by opening HV-592A & B until dry steam emerges. Reclose. Open Traps.	_____
8.	Verify TT-583 turb. steam temp. is 575°F.	_____
9.	Open FCV-501 to allow steam up to throttle valve.	_____
10.	Verify PT-581 turb. steam press. increases above 850 PSI.	_____
11.	Record time of day and wait 2 min. to warm pipe before starting turbine.	_____
12.	Establish LT-511 12" hotwell lvl. control betw. 9 & 14"	Time
	1. Continuously monitor LT-511 hotwell lvl.	
	2. Dump if LT-511 above 14" by opening FCV-511 until level drops to 12".	
	3. Make-up if LT-511 below 9" by opening FCV-512 until level rises to 11".	(Continuous)
13.	Establish FCV-521 120°F cool. oil temp. cont'l.	
	1. Continuously monitor TT-521 oil temp.	
	2. Adjust FCV-521 position to maintain TT-521 oil temp. at 120°F (betw. 110-130°)	(Continuous)

<u>STEP</u>	<u>DESCRIPTION</u>	<u>VERIFICATION</u>
-------------	--------------------	---------------------

WARNING

Clear non-involved personnel  
away from the T-G for safety.

CAUTION

Trip Turbine if operation abnormal with ET - Emerg. Trip

NOTES

1. Maintain coordination between T-G and Steam operations.
2. Verify proper turbine operation as follows:
  - a. Field monitor
    1. Turbine rolling
    2. No abnormal rubbing or noise (rod ck)
    3. No unusually excessive vibration
    4. FI-501 & 502 bearing oil flowing (sight windows)
  - b. Instruments
    1. ST-582 generator speed below 1250 rpm
    2. AZT-581 turbine vibration below 3G's  
(Emcon VIB.OVR override available, 5G trip)
    3. TT-501, 502, 507 (also TE-503, 505, 506  
at Emcon). Bearing oil temp.'s equalize  
within 20° of each other, within 50°  
of TT-521, and betw. 60 - 170°F limits.
    4. PT-502 cond'r vacuum below 15" Hg.
    5. PT-582 steam seal press. above     PSI.
    6. TT-583 steam temperature above 700°F
    7. PT-581 steam pressure above 850 PSI  
(Steam press & temp may be lower for start-up,  
but must remain above acceptable superheat)
  - c. Controls
    1. LT-511 hotwell level between 9 & 14"
    2. TT-521 cooling oil temp. between 60 & 130°F.
    3. EOP controlling hydraulic oil press. at 120 psi.  
(On at lo pressures, Off when shaft pump operating).
3. Verify ET/OST Turbine trips as follows:
  - a. PT-531 hydraulic oil press drops to '0' PSI (T.V. closed)
  - b. PT-581 press drop (stop V. closed)
  - c. ST-582 generator speed decreasing
  - d. Turbine audibly slowing down
4. Conduct the following 3 test trips to verify  
their functional operation & preheat the Turbine.

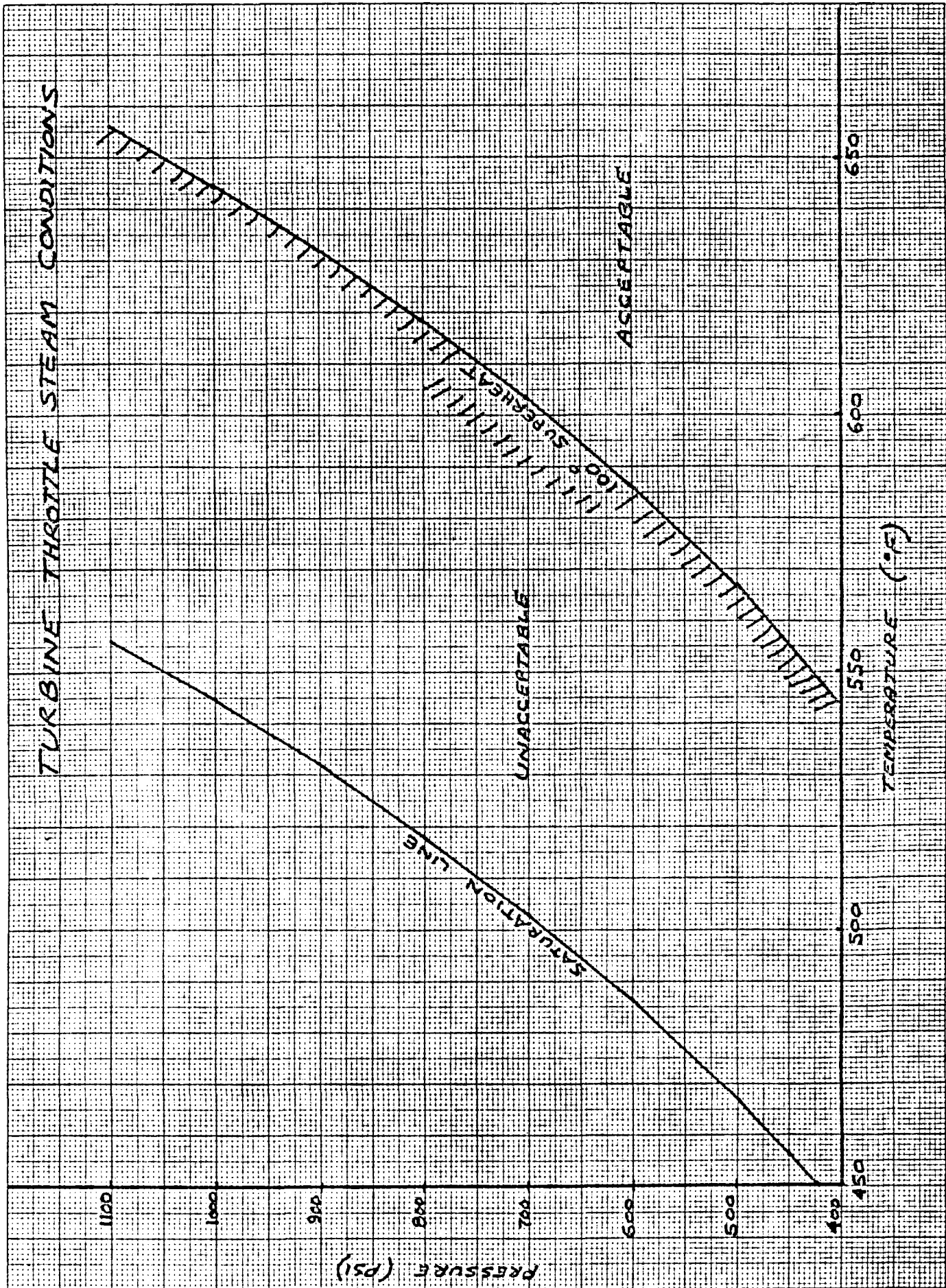



STEP	DESCRIPTION	VERIFICATION
<u>C. T-G START-UP</u>		
0.	Prewarm the Turbine after 2 min. pipe warming, by opening throttle valve manually until Turbine is just about ready to start rolling, has steam going thru it, but is <u>not</u> rolling. Wait 5 min.	_____
1.	Start the 1 <sup>st</sup> Turbine roll to half speed, after 5 minute turbine prewarming, by manually opening throttle valve until roll starts, then close slightly to roll-out very slowly and smoothly. Progressively and very slowly increase increase speed to 600 RPM. Verify proper Turbine operation (Note 2).	_____
2.	Conduct test trip 1 - Lo speed MOST (Man. Overspeed Trip):	
	a. Hit OST trip button on turbine	
	b. Verify turbine tripped (Note 3)	
	c. Reset OST mechanism	
	d. Reset throttle valve closed TVM.CLS, ZT-581 0% open	
	e. Reset EPS2.RST	
	f. Verify trip reset by PT-531 hydraulic oil pressure above 50 psi	_____
3.	Restart Turbine a 2 <sup>nd</sup> time to half speed, if trip functioned properly and before turbine stops, by reopening FCV-501 and throttle valve until generator again slowly reaches 600 RPM. Reverify proper Turbine operation (Note 2).	_____
4.	Conduct test trip 2 - Lo speed ET (Emerg. Trip):	
	a. Actuate ET Emerg. Trip	
	b. Verify Turbine tripped (Note 3)	
	c. Reset ETR FCV-561 (ET off)	
	d. Reset throttle valve closed TVM.CLS, ZT-581 0% open	
	e. Reset EPS2.RST	
	e. Verify trip reset by PT-531 hydraulic oil pressure above 50 psi	
5.	Restart Turbine a 3 <sup>rd</sup> time to full speed, if trip functioned properly and before turbine stops, by reopening FCV-501 and throttle valve until generator slowly reaches 1200 RPM. Locally guarantee ST-582 gen. speed does not exceed 1200 rpm and that govern. control holds it at 1200 rpm. Reverify proper turb. operation (Note 2). Do not prolong full speed operation unless TT-521 above 100°F	_____
6.	Conduct test trip 3 - Full speed trip. On alternate day start-ups, repeat either the MOST, the ET, or the EPS T-G trip (Control Room PB).	MOST ET PB
7.	Restart Turbine a 4 <sup>th</sup> time to full speed by reopening FCV-501 and throttle valve 100%. Locally guarantee ST-582 gen. speed holds at 1200 rpm.	_____

<u>STEP</u>	<u>DESCRIPTION</u>	<u>VERIFICATION</u>
-------------	--------------------	---------------------

- |    |                                                                                                                                       |       |
|----|---------------------------------------------------------------------------------------------------------------------------------------|-------|
| 8. | Reverify proper turbine operation (Note 2).<br>Continue manually controlling LT-511 and FCV-521.<br>Confirm CTF is on and EOP is off. | <hr/> |
|----|---------------------------------------------------------------------------------------------------------------------------------------|-------|

CAUTION

Do not continue full speed oper. unless TT-521  
oil temperature quickly increases above 110°F  
(within 5 minutes)

- |     |                                                                                                                                                                                                       |       |
|-----|-------------------------------------------------------------------------------------------------------------------------------------------------------------------------------------------------------|-------|
| 9.  | Locally turn on Exciter Disc. Sw. to start<br>Generator voltage build-up.                                                                                                                             | <hr/> |
| 10. | Verify generator no-load operation:<br><br>a. 460V at GCP meter or Emcon ET-581<br>b. 'O'A at GCP meter or Emcon IT-581<br>c. Generator air temperature below 120°F<br>(Local TI-580 or Emcon TE 508) | <hr/> |

CAUTION

Synchronize the generator ASAP after achieving  
turbine full speed and generator voltage to  
minimize high turbine exhaust temperatures.  
TI-581 or TE-581 should be kept below 150°F.

NOTES

1. A control transfer from local to Emcon may be done before or after syuch. Coordinate with Emcon operator and verify he has completed his control transfer checklist. Transfer by switching TCP key sw from local to remote.
2. During the turbine heat soak, SGS salt flow can be reduced to the minimum required to maintain 1100 psi steam (controlled by HRFS FCV-431) to conserve hot salt.

STEP	DESCRIPTION	VERIFICATION
D.	<u>GENERATOR SYNCHRONIZING / LOCAL OR EMCON</u>	
1.	Verify that T-G operation is established and then continue to complete this synch. procedure ASAP. A control transfer from local to Emcon may be done at this point.	Local <input type="checkbox"/> Emcon <input type="checkbox"/>
<u>NOTE</u>		
Synchronizing control location coincides with turbine control location (i.e., Local - GCP or Remote - RGP) as determined by TCPMS.		
2.	Advise the steam operator to prepare for Gen. Sync. by increasing SGS salt flow to 10 klbs/hr, (FCV-321 in flow control), and insuring that HRFS FCV-431 is in steam press. control. Verify that he has done so before proceeding.	_____
3.	Verify gen. speed above 1150 rpm and adjust to rated speed of 1200 rpm and freq. of 60 HZ with the governor control sw.	_____
4.	Adjust the generator sync voltage using the voltage control switch until the running volts equals incoming volts at approximately 120 v. + 2 V.	_____
5.	Install the sync sw handle and place the sync sw in the ON position. Verify sync LT's and synchroscope operation.	_____
6.	Adjust the generator speed with the governor control switch until the pointer on the synchroscope slowly rotates in a clockwise (fast) direct.	_____
<u>CAUTION</u>		
The generator must be in sync prior to closing the generator circuit breaker.		
7.	When the pointer is just before 12 o'clock with the sync lights out, close the generator circuit breaker.	_____
8.	Verify the generator C/B closes by red light on.	_____
9.	Partially load the generator to about 25 KW by raising the turb. gov. setting with the governor control switch.	_____
10.	Adjust the power factor between 1 and .8 lag with the voltage control switch ( 5 - 10 KVARs at VT-581).	_____
11.	Turn off the sync switch, record time and heat soak the Turbine for 15 minutes at this load. A control transfer from local to Emcon may be done at this point.	_____ Time
12.	Start conducting T-G hourly checks.	_____

CAUTION

On-line generator breaker trips automatically initiate a turbine trip by FCV-501 closure.

POP #2A EPGs HOURLY OPERATING CHECKLIST

TEST DATE  
UPDATED 11/14/84

RECORD AND CALCULATE KWH GENERATED BEFORE RUN \_\_\_\_\_ X 480 = \_\_\_\_\_  
 RECORD AND CALCULATE KWH GENERATED AFTER RUN \_\_\_\_\_ X 480 = \_\_\_\_\_  
 CALCULATE KWH GENERATED TODAY \_\_\_\_\_

Verify all Parameters 1/2 Hourly or Hourly as shown.  
 Record Values for Parameters indicated 'R'.  
 Primarily Monitor Gauge Values,  
 Compare & Confirm TCP & Emcon values

AREA	PARAMETER	LOCAL	TCP/EMC	EMCON	VALUE	V	TIME						
							1	2	3	4	5	6	
COND'R	COND'R VAC.	PI-584	PT-502		>15"vac R								
	TURB. COND'R EXH or (STEAM) TEMP	TI-581		TE-581	130-150°F R								
	HOTWELL (CONDENSATE) TEMP	TI-582			110-130°F R								
	HOTWELL LVL.	LI-581	LT-511		9-14"								
	COND'R GLYCOL C.W.	IN. TI-584 OUT. TI-583 IN. PI-586	TE-486 TE-484		<120°F R <120°F R 16 PSI R								
60' LVL	AEP EP. TK LVL.	LI-583			4-6"								
	AEP C.W. TEMP	TI-590			<120°F R								
	CNP SUCT. DISCH	PI-585 PI-589		PT-583	R 250-550 PSI R								
TANKS	CNT LVL.	LI-584			12-20"								
	CTP LVL	LI-585			16-20"								
	CTP	PI-588 PI-587			1" Hg V.16. 30-35 PSI R								
	C.W.			TE-582	<100°F R								

NOTE - ON THE FIRST ROUND OF THIS CHECK, BLEED OFF AIR FROM THE C.W. SYSTEM OF THESE HEAT EXCHANGERS:  
 - Condenser Water Exch. (HV-593 (HV-512))  
 - Turbine Oil Cooler  
 - Gen. Air Cooler

AREA	PARAMETER	LOCAL	TCP/EMC	EMCON	VALUE	V	1	2	3	4	5	6
TURB	OIL LVL.	DIPSTICK LI-582			OPER. LVL MARK							
	OIL FLOW	FI-501			FLOW							
		FI-502			FLOW							
	OIL PRESS	BRG. PI-581	PT-501		>6 PSI							
		HYD. PI-582	PT-531		>50 PSI							
	BRG OIL TEMP.			TT-501		140-150°F	R					
				TT-502		140-150°F	R					
					TE-503	140-150°F	R					
					TE-505	140-150°F	R					
					TE-506	140-150°F	R					
				TT-507		140-150°F	R					
	COOLER OIL TEMP.	TI-586	TT-521		80-130°F	R						
	COOLER C.W. TEMP.	IN TI-588			<100°F	R						
		OUT TI-587			<100°F	R						
	MAIN ST.			PT-581		850 PSI	R					
			TT-583		750°F	R						
ST. SEAL	PI-583				0-2 PSI	R						
	PI-580	PT-582			50-100 PSI	R						
GEN	AIR TEMP	TI-580		TE-508	<100°F <40°C	R						
	C.W. TEMP	TI-589			<120°F	R						
	STATOR TEMP				TT-510	<200°F	R					
					TT-511	<200°F	R					
					TT-512	<200°F	R					
					TT-513	<200°F	R					
				TT-514	<200°F	R						
				TT-515	<200°F	R						
GEN ELECT. ★	WATTS		JT-581		<750 KW	R						
	VARS		VT-581		<500 KVAR							
	VOLT		ET-581		460V							
	CURRENT		IT-581		<1200 A							
	POWER FACTOR		PET-581		1 Tr. .8 Lag							
FREQ		ST-581		60 Hz								

★ Instruments listed are at GCP/EMC.

STEP      DESCRIPTIONVERIFICATIONA.    LOCAL START-UP COORDINATION

Complete these items at the request of the local EPGS operator.

- |    |                                                                                                                                      |       |
|----|--------------------------------------------------------------------------------------------------------------------------------------|-------|
| 26 | 1. Momentarily enable EPS3.RST and EPS2.RST if required.                                                                             | _____ |
| 20 | 2. Verify Condenser C.W. temperature TE-486 is below 100°F.                                                                          | _____ |
| 18 | 3. Transfer primary D/D level control from CMUP to CNP by activating FCV-471 with a SP of 15" and resetting the SP of FY-472 to 14". | _____ |
|    | 4. Verify PT-431 above 1000 psi and TE-483 above 600°F.                                                                              | _____ |
|    | 5. Place/confirm SGS in manual salt flow control (5 klb/hr min. steam flow) with FCV-431 activated and MAN.321 on.                   | _____ |

B.    EPGS CONTROL TRANSFER CHECKLIST

Complete this checklist before transferring EPGS control from Local to Emcon (TCPMS 'OFF' to 'ON') after T-G operation is locally established (POP #2A). PCK may be used to auto align these, turning itself off when complete.

- |    |                                                                |       |
|----|----------------------------------------------------------------|-------|
| 22 | 1. Turn on FCV-501.                                            | _____ |
| 21 | 2. Enable the auto. hotwell level control EN.HLC.              | _____ |
| 21 | 3. Verify that lube oil cooling FCV-521 is in auto S.P. 120°F. | _____ |
| 21 | 4. Turn on the following enable and control signals:           |       |

CTP	CTF	CNP
CTP.EN	CTF.EN	CNP.EN
		AEP
		AEP.EN
		EOP
		EOP.EN

- |    |                                               |       |
|----|-----------------------------------------------|-------|
| 33 | 5. Enable <u>EPGS</u> operational alarms PAL. | _____ |
|----|-----------------------------------------------|-------|

NOTE

Control transfer may be completed before or after synchronizing. Follow POP #2A guidelines to synch.

- |    |                                                                                                              |       |
|----|--------------------------------------------------------------------------------------------------------------|-------|
| 6. | Coordinate transfer with EPGS technician, accomplished by him switching TCP key switch from local to remote. | _____ |
|----|--------------------------------------------------------------------------------------------------------------|-------|

STEP	DESCRIPTION	VERIFICATION
<u>C. STEAM CONTROL TRANSFER</u>		
24	1. Transfer SGS steam control from manual salt flow to boiler following mode. <ul style="list-style-type: none"> <li>a. Assure steam flow FT-311 is 5 klb/hr or more with FCV-321 in manual (SGS in manual flow control, FCV-431 is controlling steam line pressure).</li> <li>b. Load turbine generator to 50-100 KW, 10-20 KVARs.</li> <li>c. Verify FCV-321 is cascaded at Net 90 in preparation for it to assume control.</li> <li>d. Turn off MAN.321. This puts FCV-321 in auto, controlling steam pressure at 1100 psi. (SGS in boiler following mode). Note FCV-431 is also in auto SP 1080 psi at this time.</li> <li>e. Once FCV-321 has stabilized, (ZT-321 doesn't fluctuate too much), immediately continue on. (Otherwise deactivate FCV-431 &amp; manually control.)</li> </ul>	_____ _____ _____ _____ _____
24	2. Prepare for Gen. Loading by completing the following to actuate GSTAT (Gen. status). GSTAT is only used when the T-G is on-line. Its function is to shift FCV-431 casc. control from steam line pressure PT-431 to D/D press. PT-432. D/D overpress. is limited by FCV-432. <ul style="list-style-type: none"> <li>a. Verify PT-432 is in auto SP 225 psi. When PT-432 goes above 225 psi, turn on GSTAT.</li> <li>b. Continue to monitor FCV-321, FCV-431, FCV-432 to ensure GSTAT is functioning properly.</li> </ul>	_____ _____

D. GENERATOR LOADING

CAUTION

Coord. gen. load changes with the steam system and do not increase gen load faster than 75 kw/min. SGS load following cannot exceed a steam flow ramp rate of 10%/min.

1. Determine & adjust generator load to required load conditions using the gov. and volt. control switches.

CAUTION

Do not exceed rated load conditions of 750 KW at 0.8 P.F. lag (between 0.8 & 1.0 lag)

2. Monitor the attached list of T-G operating parameters. Verify the local T-G hourly checklist is being completed.

'ELECTRIC POWER PRODUCTION'

POP #2 EPGS OPERATION

---

Monitor these parameters intermittantly during T-G operation from Emcon:

<u>GROUP</u>	<u>PARAMETER</u>	<u>DESCRIPTION</u>	<u>VALUE</u>	<u>PARTICULARLY</u>
23	JT-581 VT-581	KW generation KVAR generation	0 - 750 KW 10 - 20 KVAR	Watch for creep Adjust with load
22	TT-501 TT-502 TE-503 TE-505 TE-506 TT-507	Brg. oil temps	110 - 160 °F	Establish stability
23	TT-510 TT-511 TT-512 TT-513 TT-514 TT-515	Gen. stator temps	150 - 200 °F	Establish stability
22	PT-581 TT-583	Steam pressure Steam temp.	above 750 psi above 750 °F	Trip parameter Trip parameter
call-up	TT-509	Gen. air temp	below 110 °F	Trip parameter
22	PT-502	Condenser vacuum	below 15 "Hg.	Affects KW generation
22 21	LT-511 FCV-521	Hotwell level Oil temp. control	9 - 14 " 120 °F	Controls check Controls check
call-up	TE-581	Turb. exh. temp	130 -150 °F	Minimize overtemp.



STEP    DESCRIPTION

VERIFICATION

A. T-G Manual Emerg. trip

NOTE

Initiate emerg shutdown only if necessary,  
but do not hesitate if emerg. conditions exist.  
Advise all operators of actions ASAP.  
If possible, try to reduce generator load  
before trip with governor control switch.

1.    Open generator breaker with breaker CS  
      or Actuate ET  
      or Actuate EPS T-G trip button from control room.  
      (Operate all 3 for safety)

C.S.    ET.    EPSTGT

CAUTION

Stay clear of T-G/generator breaker for safety.  
Expect HRFS & SGS safety relief valves to open.  
SGS salt flow will stop and HRFS will attempt  
to desuperheat steam.

2.    Verify trip; turbine speed decreasing, gen. breaker open. \_\_\_\_\_
3.    When safe and orderly, proceed with manual shutdown  
      Step 6. \_\_\_\_\_

B. T-G Normal Shutdown

1.    Establish communications with Emcon operator to coordinate  
      generator load shedding with steam reduction operations. \_\_\_\_\_
2.    Reduce generator load by lowering governor control switch  
      and voltage control switch. Do not reduce load faster  
      than 75 kw/min. (Do not exceed  
      an SGS steam flow reduction rate of 10%/min.)  
      A control transfer may be done here. \_\_\_\_\_

NOTE

Opening the gen. bkr CS automatically  
initiates a turb. trip by FCV-501 closure.

3.    Shutdown the T-G by opening the generator breaker with the  
      breaker control switch as generator load is reduced to zero  
      with the governor control switch. \_\_\_\_\_
4.    Verify generator breaker open by green light on. \_\_\_\_\_

<u>STEP</u>	<u>DESCRIPTION</u>	<u>VERIFICATION</u>
5.	Verify turbine trip by FCV-501 closure (Emcon ZSL501 on), turbine steam press PT-581 decrease to zero and generator speed ST-582 decreasing. Manually close FCV-501 control switches also.	_____
6.	Verify T-G speed ST-582 decreases to zero.	_____
7.	Verify throttle valve reset closed by ZT-581 0% open.	_____
18 8.	Emcon operator deactivate FCV-471 and change FY-472 SP to 15"	_____
9.	Record time of day to allow 20 min. turbine/condensor vapor extraction before AEP shutdown (Step 16). As req'd, continue with shutdown up to that step.	_____ Time
10.	Emcon operator turn off GSTAT and deactivate alarms (PAL off). A control transfer may be done at this point.	_____
<u>'T-G SHUTDOWN'</u>		
C. <u>EPGS Shutdown</u>		
11.	If operating locally, adjust LT-511 hotwell level to 12", then close TCP switches for FCV-501, 511, 512, 541, & 551.	_____
12.	Turn off CNP.	_____
13.	Insure 20 min. have elapsed after T-G shutdown (Step 10) before proceeding.	_____
14.	Close cooling oil temp control FCV-521.	_____
15.	Place sel. sw. in hand and turn off EOP.	_____
16.	Turn off AEP.	_____
17.	Turn off CTF.	_____
18.	Turn off CTP, unless still required for HRFS/FWP.	_____
19.	Complete the EPGS post test check-list.	_____ As req'd

This electric Power generation operating procedure will be utilized to verify EPGS integrity following all tests that use the EPGS. This checklist shall be completed by the EPGS technician.

<u>STEP</u>	<u>DESCRIPTION</u>	<u>VERIFICATION</u>
1.	If used, remove the GCP synchronizing switch handle and return it to the MSEE key box.	_____
2.	Turn off local starters. Do <u>not</u> turn off CTP if being used for HRFS/FWP.	_____
	a. CTF	
	b. CTP	
	c. AEP	
	d. EOP	
	e. CNP	
	f. Exciter Disconnect	
	g. Throttle Valve Disconnect	
3.	Verify oil heater and generator heater local starters are on, TCP switches are in auto, and Emcon 'OH.ON' is off.	_____
4.	Turn off Exciter cabinet vent fans.	_____
5.	Verify EPGS UPS has 2 green lights on.	_____
6.	Record, then Reset any trip functions.	_____
7.	Verify throttle valve is reset closed by inspection. No unthreaded rod showing on cylinder screw.	_____
8.	Verify FCV-501 is closed by inspection.	_____
9.	Close these valves:	_____
	a. HV-579 Hotwell make-up Tanks at 80' Level	
	b. HV-585 Hotwell dump Tank at 80' Level	
	c. HV-406 Condensate to HRFS CMUP room at 80'	
10.	Drain hotwell through CNP S-581 HV if extended shutdown planned (longer than 1 week).	_____
11.	Verify no evidence of leaks or other abnormalities found.	_____
12.	Notify control room that the EPGS post-test has been completed. (EPGS is secured), length of time on the grid, and KWH's generated today.	_____

EPGS  
MAINT.  
1/1

VI EPGs MAINT. SCHEDULE CHECKLIST UPDATED 3/27/84

EQUIP	MAINT.	T-G MAN.	DESCRIPTION	INTERVAL	PERFORM BY / DATE
TURB. TRIP. MECH.	TRIP CHECK	PG 36	SEE TRIP CHECK PROCED'S	3 MNTH	
STRAINERS	CLEAN		TURB. DUPLEX OIL STRAINER FLUSH OUT THRU HV: S-581 CNP SUCTION S-582 CTP SUCTION S-583 AEP CERER M-U	3 MNTH	
RELIEF VV's	INSPECT	PG 10 PG 18	Verify Free To Operate, NO Tampering / Kneeting evident RV-581 TURB 10 PSIG RV-582 AEP 26" Hg. RV-583 OIL 60 PSIG RV-584 COND'R 20 PSIG	3 MNTH	
INSTR'S	CALIB		Check f/or Recalib., Verify Meter/Emcon Indic. LT-511 HSTwell Lub ST-582 Gen. Speed	3 MNTH	
CONTROL VV's	CALIB		Check f/or Recalib. Air Reg, PosiT. (Zero & Span) Feedback Indic (P/I, RT, LMS) FCV-471 COND'T RET FCV-501 Main Steam FCV-521 Oil Cooling	3 MNTH	Sandia Plant
Oil Cool. Turb	CLEAN		Remove Debris & Sealing	3 MNTH	
GENER.	INSPECT	PG 41 PG 41	CHECK BRUSHES, MEGGER WINDINGS	3 MNTH	
TURB.	INSPECT	PG 26 PG 37	VERIFY ALIGNMENT: OST TRIGGER CLEARANCE GEAR TEETH CONTACT	3 MNTH	
STEAM STRAINER	INSPECT	PG 35	Behind T.V. Motor Oper.	1 YR.	
TURB. OIL	REPLACE	PG 40	CHEV. GST 46 60 GAL	1 YR	
MOTORS	GREASE	PG 35	SCHED. THRU SANDIA PLANT EOP CNP AEP CTP CTF T.V. Motor Oper. SYNG. MTR.	1 YR	
TURB. LINKAGES	OIL	PG 35	T.V. & GOV. VV. Link's	1 YR	
T-G	OVERHAUL	PG 34	REJUVINATE SET	2 YR	

VII. EPGS TRIP CHECK PROCEDURES

The Turbine must not be kept in service unless it is positively known that the entire trip system is in working order. Trip checks should be conducted every 3 months.

A. MGBT - Man. gen. bkr. trip. - Static check. Updated 4/24/84

As the normal T-G shutdown method, this trip will normally be verified during operation. It is included here to establish familiarity with the normal shutdown method and/or allow verification of its operation because of doubt or inoperation.

<u>STEP</u>	<u>DESCRIPTION</u>	<u>Test Date</u>
		<u>VERIFICATION</u>

WARNING

Verify no steam is present. Do not attempt to close gen. ckt. bkr. without racking it into the test position.

(Set-up)

- |    |                                                    |       |
|----|----------------------------------------------------|-------|
| 1. | Locally rack generator breaker into test position. | _____ |
| 2. | Reset all circuit breaker trips - EPS, ET.         | _____ |
| 3. | Locally close HV-501.                              | _____ |
| 4. | Open FCV-501.                                      | _____ |
| 5. | Open turbine throttle valve.                       | _____ |
| 6. | Install synchronized switch handle & turn on ss.   | _____ |
| 7. | Close generator breaker with C.S., verify closed.  | _____ |

(Trip Test)

- |     |                                                                                           |       |
|-----|-------------------------------------------------------------------------------------------|-------|
| 8.  | Open generator breaker with c.s., verify breaker open.                                    | _____ |
| 9.  | Verify FCV-501 closes (32X relay energized).                                              | _____ |
| 10. | Verify turbine throttle valve is driven closed, ZT-581 0% open.                           | _____ |
| 11. | Verify FCV-501 reopens (32X relay de-energizes when turbine throttle valve reset closed). | _____ |
| 12. | Return system to normal shutdown condition.                                               | _____ |

EPGS TRIP CHECK PROCEDURES

B. EPST - Equipment Protection System Trips - Static Check Updated 4/24/84

Each of these trips close 1) FCV-501 and 2) Gen ckt. bkr. They are simulated by placing the EPS cab. 2 & 3 key switch in test and selectively testing each trip by push buttons on the front of EPS 2 or 3. The circuit breaker & valve need only be test tripped once and thereafter only confirm the EPS/CBT & 501 relays in the back of TCP energize.

Test Date  
VERIFICATION

STEP    DESCRIPTION

WARNING

Verify no steam is present. Do not attempt to close gen ckt. bkr. without racking it into the test position.

(Set-Up)

- |    |                                                    |       |
|----|----------------------------------------------------|-------|
| 1. | Locally place EPS cab. 2 & 3 in test.              | _____ |
| 2. | Locally rack generator breaker into test position. | _____ |
| 3. | Reset all circuit breaker trips - EPS, ET.         | _____ |
| 4. | Locally close HV-501.                              | _____ |
| 5. | Open FCV-501.                                      | _____ |
| 6. | Install synchronized switch handle & turn on SS.   | _____ |
| 7. | Close generator breaker with CS, verify closed.    | _____ |

(Trip Test)

- |     |                                                                                                                                                                                              |       |
|-----|----------------------------------------------------------------------------------------------------------------------------------------------------------------------------------------------|-------|
| 8.  | Selectively test each trip in the chart following (setpoint provided for reference only) by pushing its test button at EPS 2 or 3; or alternatively, by actuating the top initiating device. | _____ |
| 9.  | Verify FCV-501 closes.                                                                                                                                                                       | _____ |
| 10. | Verify generator breaker opens.                                                                                                                                                              | _____ |
| 11. | Verify Emcon "TR" trip alarm operation.                                                                                                                                                      | _____ |
| 12. | Reset EPS 2 or 3.                                                                                                                                                                            | _____ |
| 13. | Reclose FCV-501.                                                                                                                                                                             | _____ |
| 14. | Repeat test for each trip in chart.                                                                                                                                                          | _____ |
| 15. | When complete, return system to normal shutdown condition including placing EPS 2 & 3 key switch back in operating position.                                                                 | _____ |

EPST  
T-G TEST TRIP LIST  
UPDATED  
4/24/84

EPS CAB.	TRIP I.D.	DESCRIPTION	INITIATING DEVICE	TRIP SETPOINT
1.	2	TR-583 TURB. OIL PRESS LO (ONLY ENABLED IF FCV-501 OPEN)	PS-501A (LUDE) or PS-531A (HYDR) and ZSL-501	Below 6 PSI Below 50 PSI
2.	2	TR-584 GEN. BRG TEMP. HI	TS-501A	Above 180°F
3.	2	TR-585 GEN AIR TEMP. HI	(TE-509) (TT-509) TS-502A	Above 122°F
4.	2	TR-586 GEN. CKT. BKR. TRIP	32X	MAN., U.V., O.V., G.F.
5.	2	TR-587 TURB. VIBRAT. HI (ONLY ENABLED IF VIB.OVR OFF)	AZT-581 and VIB.OVR. OFF	Above 5 G's
6.	2	TR-588 SUPERHEATED STEAM LOSS (ONLY ENABLED IF FCV-501 OPEN)	TT-332 or PT-581A and ZSL-501	Below 750°F Below 770 PSI
7.	2	— PCM-2 FAILURE & ST. PRESS. DECAY	PCM-2 & PT-581A	OFF & Below 850 PSI
8.	3	— PCM-3 FAILURE	PCM-3	OFF
9.	3	TR-381 (EGS) ST. DRUM LVL LO	NET. 90 (LT-311)	Below -15"
10.	3	TR-382 (EGS) CWCP FAILURE	NET. 90	OFF
11.	3	TR-383 (EGS) ST. DRUM LVL HI	NET. 90 (LT-311)	Above +17"
12.	3	TR-186 (TSS) BOOST. Pp. SUMP LVL HI	TE-181A	Above 450°F
13.	(2)	TR-582 MAN. T-G EMERG. TRIP	CONTROL ROOM P.E.	OPERATOR INITIATE *
14.	(3)	— MASTER TRIP	CONTROL ROOM P.E.	OPERATOR INITIATE *

NOTE TWO OTHER FAILURES INITIATE EPST T-G TRIPS  
BUT ARE NOT INCLUDED ABOVE - NO TESTING MEANS PROVIDED.  
THEY ARE CONT'L FAILURE (ALL PCM'S) & CCM FAILURE (PARALLELS EPS MT).  
\* ONLY TEST IF ALL MSEE SYSTEMS ARE NOT OPERATING.

\* Init. by  
RGP  
M. Tol. PB

EPGS TRIP CHECK PROCEDURES

---

C. OST - Overspeed Trip - Operating Check

Updated 4/24/84

When conducting this test, it is important that every precaution be taken to prevent the speed of the turbine from exceeding the correct tripping limitations. The turbine should be brought momentarily to tripping speed (19,187 turbine rpm, 1320 generator rpm) and no higher.

The attached procedure to be used is from the G.E. T-G Manual, page 36 and figure 27.

\_\_\_\_\_  
Test Date

\_\_\_\_\_  
Verification

D. BPT - BackPressure Trip

Updated 4/24/84



Operate the emergency trip by pressing on the trip button, seeing that the throttle-valve tripping device unlatches, and that the valve closes. When the above safety measure has been taken, to insure the set against damage through uncontrolled speeding, continue the test in the following manner:

1. Connect an accurate indicating tachometer to the generator end of the shaft. Have a man at the tachometer in direct communication with the man located at the throttle valve.

2. At the synchronizing device (Fig. 27), depress the pin (19) on the high-speed stop (5) and turn the handwheel (1) as far as it will go in the speed-increasing direction.

3. Start the turbine, and immediately after the rotor begins to turn, trip the emergency mechanism by pressing the trip button. If the throttle valve does not close promptly, investigate and correct the trouble before proceeding with the test. If the throttle valve does close promptly, turn the throttle handwheel to the closed position, reset the tripping mechanism, and then proceed with the test.

4. Open the throttle valve just enough to bring the turbine slowly up to tripping speed (19,187 rpm turbine speed or 1320 rpm generator speed). Do not accelerate or run above the tripping speed.

5. Take careful readings of the tachometer to determine the speed at which the emergency governor operates.

6. Be sure that the tripping mechanism closes the throttle valve when the emergency governor operates.

7. In case the emergency governor does not trip at the proper speed, make no adjustment to any part of the mechanism until the trouble has been located.

8. Always trip the emergency governor at least three times after setting the governor to be certain that the speed readings have been taken correctly and also that all parts are in proper working order.

9. Depress the pin (19, Fig. 27) to clear the projection on the bottom of the fulcrum (4) and turn the

handwheel (1) in the speed-decreasing direction until the fulcrum is again within the normal operating range.

10. Do not keep the turbine in service unless it is known that the emergency devices are accurately adjusted and are in operative condition.

EPG S  
TRIP CK.  
5/6

## ADJUSTMENT OF TRIPPING SPEED

The tripping speed is tested at the factory and should not be changed unless it is absolutely necessary. The correct speed is ten per cent above normal, corresponding to a turbine speed of about 19,187 rpm and a generator speed of about 1320 rpm. The plunger is contained in a transverse opening in the body (1, Fig. 29) that contains all parts of the emergency governor. These parts are held in position by the plug (6) which in combination with shim spacer (3) fixes the position of the plunger at speeds below the tripping speed. The speed at which the plunger trips the trigger is determined by the thickness of spacers. Check the tripping speed three times or more. Then restake the bushing to the body.

Take careful readings on a reliable tachometer for measuring the speed of the turbine when adjustment of the emergency governor is being made.

## ADJUSTMENT OF TRIGGER CLEARANCE

The clearance between the emergency governor plunger and the trigger (26, Fig. 30) when the turbine is at rest and the trigger is latched in position is 1/64 inch to 1/32 inch. To measure this clearance, remove the access cover from the outboard end of the turbine.

## JOURNAL BEARINGS

Bearing-lining halves are not interchangeable with those of other bearings. When ordering renewal parts, both the top and bottom halves of a bearing lining must be obtained. The turbine bearing is the thin liner type which normally cannot be rebabbitted. Spare should be used in case of replacement.

# SECTION 2

## Maintenance of Gear

### DISASSEMBLY

#### Upper-half Gear Casing

1. Remove the turbine valve gear levers (10 and 31, Fig. 21), lever (1, Fig. 25) and bushing (3, Fig. 25).

2. Remove all thermometers from the upper-half casing.

3. Remove the thrust bearing cover (6, Fig. 33) and disassemble the thrust bearing by removing the

EPGS  
TRIP CK.  
6/6

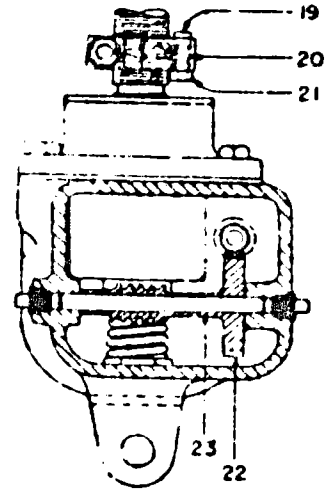
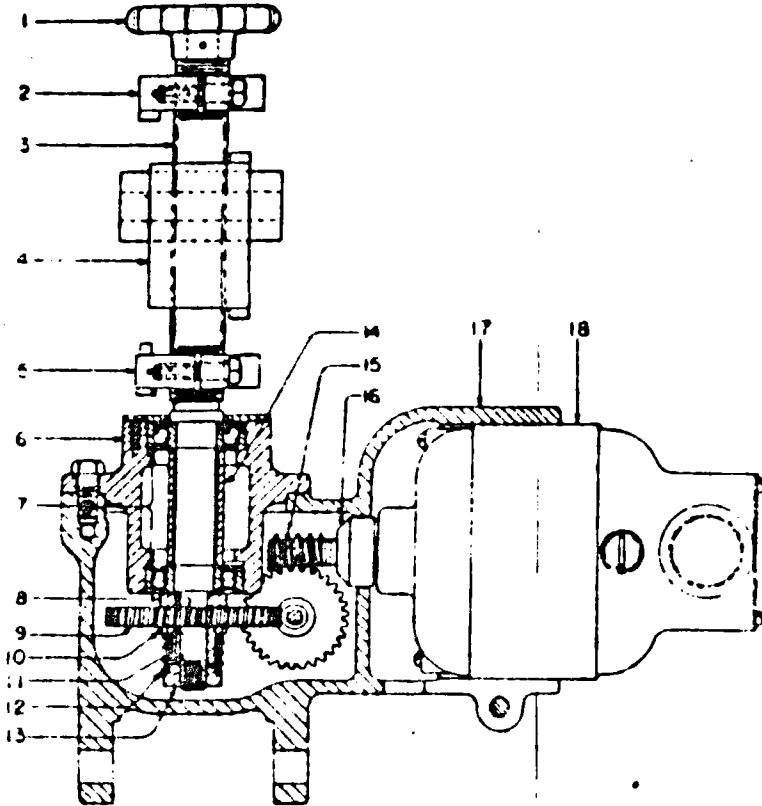
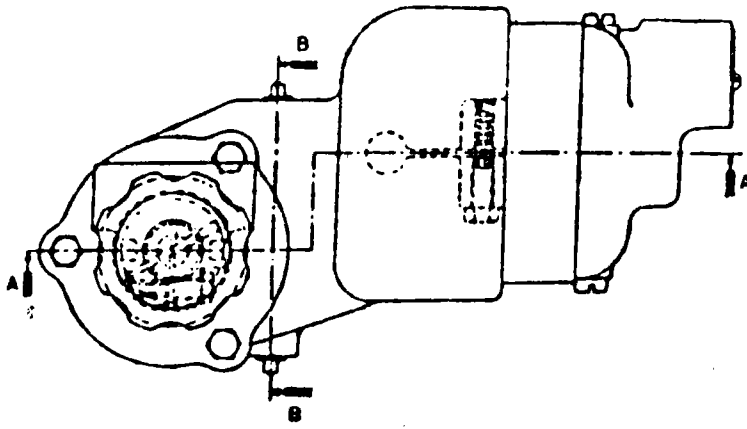

Section "B-B"

Section "A-A"

- |                                |                     |
|--------------------------------|---------------------|
| 1 Handwheel                    | 13 Adjusting collar |
| 2 Low-speed stop               | 14 Sleeve           |
| 3 Spindle                      | 15 Worm             |
| 4 Pulverum                     | 16 Collar           |
| 5 High-speed stop              | 17 Gear housing     |
| 6 Bearing housing              | 18 Motor            |
| 7 Ball bearing, MRC No. 204SP7 | 19 Pin              |
| 8 Thrust washer                | 20 Spring           |
| 9 Gear                         | 21 Collar           |
| 10 Thrust washer               | 22 Worm gear        |
| 11 Key                         | 23 Shaft            |
| 12 Spring                      |                     |

## A. Definitions

1. Turbine Trip - Immediate turbine steam shutoff - manual or auto.
2. Turbine Shut-Down - Gradual turbine steam shutoff - manual.
3. Generator Trip - Generator Circuit Breaker opened - manual or auto.

## B. Steam reactions to trips

1. Anticipated -- Steam control maintained manually or auto.
2. Upset - Reliance on auto steam control - SGS salt flow will stop and HRFS will attempt to desuperheat steam. Probable HRFS & SGS safety valve lifting if upset is uncontrolled.

## C. Trip Interlocks

1. A generator breaker trip always initiates a turbine SVC trip (auxilliary relay 32x closes FCV-501) and an EPST TR-586 (32x).
2. A generator breaker trip always initiates a turbine T.V. reset (auxilliary relay 32x resets T.V. closed) w/ZT-581 '0' % open.
3. A turbine T.V. reset and an EPS 2 & 3 reset will reopen FCV-501 unless manually closed (or tripped).

## D. All auto trips should be carefully reviewed - determine the cause of the trip and correct the problem before resuming operations.

T-G TRIP LIST

1/4

NO	MODE	DESIGNAT.	INITIATION	RESULT	FLAG	REACTION	FLAG	COMMENT
1	MAN	<u>EPS MT</u> EQUIP. PROT. SYST. MASTER TRIP	<u>CONT'L RM</u> <u>OPERATOR</u> EPS MT BUTTON HIT	<u>T-G TRIP</u> FCV-501 closes GEN. BKR. Trip	PT-581 Zero PSI 'G' BKR Open LT	Start T.V. Reset Redund EPST (32X)	ZT-581 Reset 0% Op. + ZSL501 actuated	
2	MAN.	<u>MGET</u> MAN GEN. BKR TRIP	<u>OPERATOR</u> BKR C.S. OPENED	G TRIP	'G' BKR Open LT.	<u>T Trip</u> FCV-501 closes Start T.V. Reset Redund EPST (32X)	PT-581 Zero PSI ZT-581 Reset 0% Op. ZSL-501 actuated	NORMAL T-G SHUTDOWN  NOT FUNCTIONAL UNLESS BREAKER IS CLOSED
3	MAN.	<u>ET</u> EMERG TRIP	<u>CONT'L LOCAT.</u> <u>OPERATOR</u> ET ACTUATED	<u>T-G TRIP</u> SOV FCV-501 opens To dump Hydr. Oil and Trip T.V. Gen. BKR. Trip	PT-581 Zero PSI 'G' BKR Open LT.	FCV-501 closes Start T.V. Reset Redund EPST (32X)	PT-581 Zero PSI ZT-581 Reset 0% Op. ZSL-501 actuated	REQUIRES MAN. ET, RESET
4	MAN	<u>EPSTGT</u> EQUIP. PROT SYST T-G TRIP	<u>CONT'L RM</u> <u>OPERATOR</u> EPS TGT BUTTON HIT	<u>T-G TRIP</u> SOV FCV-501 opens To dump Hydr Oil and Trip T.V. Gen. BKR. Trip.	PT-581 Zero PSI 'G' BKR Open LT.	FCV-501 closes Start T.V. Reset Redund EPST (32X)	PT-581 Zero PSI ZT-581 Reset 0% Op. ZSL-501 actuated	REQUIRES MAN EPSTGT RESET
5	MAN	<u>SVC</u> STOP VALVE CLOSURE	<u>CONT'L LOCAT.</u> <u>OPERATOR</u> FCV-501 CLOSED	<u>T-G TRIP</u> FCV-501 closes GEN BKR Trips	PT-581 Zero PSI 'G' BKR Open LT	Start T.V. Reset Redund EPST (32X)		
6	MAN.	<u>MOST</u> MAN. OVERSPEED TRIP	<u>LOCAL</u> <u>OPERATOR</u> OST MECHAN. BUTTON HIT	<u>T TRIP</u> OST Mechan. Dumps Hydr Oil and Trips T.V.	PT-581 zero PSI	G Trip Rev. Pur. GRT EPST Trip	'G' BKR. Open LT FCV-501 closes Redund. EPST (32X) 32 Relay Flag 86 Relay Trip	NOT NORM DONE W/ GEN. ON-LINE
7	MAN	<u>MTVC</u> MAN. THROTTLE VV. CLOSURE	<u>CONT'L LOCAT.</u> <u>OPERATOR</u> THROTTLE W CLOSED	<u>T SHUTDOWN</u> T.V. Closure SHOTS OFF Steam To Turb.	ZT-581 Decr. To 0's	G Trip Rev Pur GRT	'G' BKR Open LT. FCV-501 closes Redund EPST (32X) 32 Relay Flag 86 Relay Flag	NOT NORM. DONE W/ GEN ON-LINE  REQUIRES MAN 32 + 86 RESET

REQ'S  
MAN  
EPSTGT  
RESET

EPGS  
T-G  
TRIP LIST  
2/5

B-124

NO	MODE	DESIGNAT.	INITIATION	RESULT	FLAG	REACTION	FLAG	COMMENT
8	AUTO	<u>OST</u> OVER SPEED TRIP	EMERG. <u>GOVERNOR</u> 1320 GEN RPM	<u>T Trip</u> OST MECHAN. DUMPS Hydr Oil and Trips TV	PT-531 Zero PSI OST Mechan. Tripped	<u>G Trip</u> Rev. Pwr GET  EPS Trip	'G' Bkr Open LT. FCV-501 closes Redund. EPST (2X) 32 Relay Flag 86 Relay Flag	REQUIRES MAN OST RESET  REQUIRES MAN 32 f 86 Reset
9	AUTO	<u>EPT</u> BACK PRESSURE TRIP	<u>RPT</u> <u>DEVICE</u> 5 PSIG	<u>T Trip</u> EPT MECHAN DUMPS HYDR OIL and Trips TV	PT-531 Zero PSI	<u>G Trip</u> Rev. Pwr GET  EPS Trip	'G' Bkr Open LT. FCV-501 closes Redund EPST (2X) 32 Relay Flag 86 Relay Flag	REQUIRES MAN 32 f 86 Reset
10	AUTO	<u>SVT</u> STOP VALVE TRIP	A. <u>PS-501</u> Eng Oil Press below 6 PSI	<u>T-G Trip</u> FCV-501 closes	PT-531 Zero PSI ZSL501 Actuated	<del><u>G Trip</u></del> Redundant EPST or Rev. Pwr. GET	'G' Bkr Open LT. Redund. EPST (2X) T.V. Resets Till ZT-531 0% op.	
			B. <u>TS-501</u> Gen. Eng Temp above 180°F					
			C. <u>TS-502</u> Gen Air Temp above 120°F					
			D. <u>COMMER</u> <u>POWER LOSS</u>					
11	AUTO	<u>OPL</u> OIL PRESS LOSS	<u>OIL</u> <u>LEAK</u> / <u>PUMP</u> <u>FAILURE</u>	<u>T TRIP</u> Hydr Oil Press. Loss Trips TV & Eng Oil Press Loss Initiates SVC & EPST	PT-501 Press Lo PT-521 Press Lo	<u>G Trip</u> by EPST or Rev. PWR GET	'G' Bkr Open LT FCV-501 closes Redund. EPST (2X)	

REQ'S  
MAN  
EPST & 3  
Reset

EPST  
T-G  
TRIP LIST  
3/5

B-125

NO.	MODE	RECIPIENT	INITIATION	RESULT	FLAG	REACTION	FLAG	COMMENT
12	AUTO	<u>GBT</u> GEN. BKR. TRIP.	A. 32 Relay Rev. Pwr.	G Trip	'G' Bkr Open LT 32 Relay Flag 86 Relay Trip	<u>T TRIP</u> FCV-501 closes Redund EPST (32X) or OST	PT-581 Zero PSI ET-581 Reset 0% sp	REQUIRES MAN 32 & 86 RESET
			B. 59 Relay Overvlt GND Fault		'G' BKR Open LT 59 Relay Flag 86 Relay Trip			REQUIRES MAN. 59 & 86 Reset
			C. O.C. Trip Unit Over Current - INSTANT. - Long Time		'G' Bkr Open LT O.C. Trip Unit Indica.			MAN. RESET O.C. TRIP UNIT
13	AUTO	<u>EPST</u> Equip. Protect Syst. TRIP	A. TR-583 PS-501A BRG OIL PRESS below 6 PSI	T-G Trip FCV-501 closes Gen Bkr. Trips	PT-581 Zero PSI 'G' Bkr. Open LT.  EP52 KEM ON (T10)	Start T.V. Reset Redund EPST (32X)	ET-581 Reset 0% sp ZSL 501 actuated EP53 KAW ON (ST44) KBD.	
			B. TR-584 TS-501A GEN. Brg Temp above 180°F		EP52 KAX ON (T8)			
			C. TR-585 TS-502A GEN. Air Temp. above 120°F		EP52 KBB ON (T14)			
			D. TR-586 32X CKT. BKR Trip MAN, UV, OV, G.F.		EP52 KBB ON (T6)			MAY REQUIRE MAN. 32, 59, 86 RESET
			E. TR-587 AZT-581 TUBE VIB. HI		EP52 KAS ON (T6)			

REQ'S MAN EP52 & 3 Reset

REQUIRES MAN. 59 & 86 Reset

MAN. RESET O.C. TRIP UNIT

EP52  
T-G  
TRIP UNIT  
4/5

B-126

NR	MODE	DESIGNAT.	INITIATION	RESULT	FLAG	REACTION	FLAG	COMMENT
13 (CONT'D)	AUTO	<u>EPST</u> (CONT'D)	F <u>TR-588</u> TT-483A Main Steam Temp below 700°F	T-G Trip	PT-581 Zero PSI 'G' CKr Open LT	START TX. ReseT Redund EPST (J2X)	ZT-581 ReseT 0% Op. + ZSL 501 actuated EPS3 KAW ON (ST44) KRD	
			G. <u>TR-381</u> NET. 90 ST. DRUM LVL. LO-LO		EPS2 KAR ON (IT3)		EPS3 KAA ON (GT4) (NOT UNIQUE FLAG)	
			H. <u>TR-382</u> NET. 90 RWCP FAIL		EPS3 KKB ON (GT8)			
			I <u>TR-383</u> NET 90 ST DRUM LVL HI-HI		EPS3 KAA ON (GT4) (NOT UNIQUE FLAG)			
			J <u>TR-186</u> TE-181A BOOST PUMP SUMP LVL HI		EPS3 KJ OFF (ST34) (NOT UNIQUE FLAG)			
			K <u>PCM 2 Fail</u> PT-581A TURE. ST. PRESS below 850 PSI		EPS2 KRF ON (TTS1)			
			L <u>PCM 3 Fail</u>		EPS3 KKG OFF (GT38)			
			M <u>CONT'L FAIL</u> ALL PCM'S FAIL PT-581A TURE ST. PRESS below 850 PSI		EPS3 KAA ON (GT-4) (NOT UNIQUE FLAG)			
N. <u>CCM Fail</u>	AUTO. EPS MT							

REQ'S  
MAN  
EPS 2/3  
ReseT

EPGS  
T-G  
TRIP LIST  
5/5

B-127

These guidelines present items of concern to Fail-Safe the EPGS upon a major component failure, after a trip that did not function, or to back-up an auto trip. Intimate familiarity with these guidelines is mandatory before EPGS operation to insure safe operation, both from a personnel and equipment standpoint.

Ref. FMEA Failure Modes and Effects Analysis

Ref. GSOP #9 Manual Emergency Shutdown Procedure

Ref. EPGS T-G Trip List

Point 1. Three items are of major concern to Fail-Safe the EPGS and MSEE operating systems:

- a. Steam over-pressurization
- b. Turbine trip
- c. Generator trip

Point 2. Steam system reactions to turbine trips:

- a. Over-pressurization
- b. Possible HRFS/D-D & SGS/Steam drum safety valve lifting
- c. Desuperheating by HRFS/FCV-431 switch-over to steam control to dump steam to D/D
- d. FCV-432 D/D heat dump through SWHX & dry cooling tower

Point 3. Turbine tripping is redundant-designed and may be fully utilized with these four trips:

- a. Actuate ET emergency trip FCV-561 (oil trip)
- b. Open generator breaker with breaker C.S. (electric Trip)
- c. Actuate EPS T-G trip button from control room (EPS back-up)
- d. Manually close throttle valve with hand wheel (manual)

Point 4. Turbine-generator trip verification:

- a. ST-582 speed decreasing
- b. PT-532 hydraulic oil pressure decreasing (T.V. trip)
- c. PT-581 steam pressure drops to zero (FCV-501 trip)
- d. Generator breaker open - green light on

#### NOTE

EOP operation is not mandatory upon a turbine trip since the shaft driven oil pump provides adequate oil flow for turbine coast down.

Point 5. Generator trips are redundant-designed with turbine trips. Be aware that:

- a. EPGS UPS provides emergency back-up C/B trip power
- b. Exciter voltage shutdown local disconnect switch shuts down all of the generator electrical power.



ADDENDUM C  
TEST DATA

This addendum contains representative test data for approximately four hours of afternoon system operation. The time listed is DST and the receiver data can be assumed symmetrical about 13:00 DST.

DAY 263 1984 DATA.7:00-17:00

TIME DAY:HR:MI:SE	TE101 DEG F	TE102 DEG F	FT101 100 LB/H	FD101 K/LBS	FCV101 PERCENT	FCV102 PERCENT	TE103 DEG F	TE104 DEG F	TE105 DEG F	TE106 DEG F
263:12:56:13	575	1021	734	74	55	53	579	586	613	588
263:12:57:13	574	993	609	63	64	64	580	585	613	570
263:12:58:13	574	991	516	53	71	71	580	587	609	579
263:12:59:12	574	998	609	61	66	66	579	584	606	606
263:13:0:12	574	997	625	61	66	66	579	587	608	620
263:13:1:13	573	997	563	56	68	68	579	588	609	616
263:13:2:13	573	1004	578	57	67	66	579	590	611	615
263:13:3:14	573	1001	531	52	68	68	580	591	614	612
263:13:4:13	573	997	500	50	70	70	580	592	613	610
263:13:5:13	575	997	500	51	70	70	580	593	613	609
263:13:6:13	574	1000	516	51	70	70	580	591	613	609
263:13:7:12	575	997	516	51	69	69	581	593	615	610
263:13:8:13	574	1000	484	49	70	70	580	593	614	606
263:13:9:13	575	999	484	49	72	72	581	589	613	604
263:13:10:13	574	998	453	45	75	75	581	591	613	599
263:13:11:12	575	1013	547	52	70	70	581	590	616	569
263:13:12:13	574	1017	625	62	65	65	580	585	611	583
263:13:13:13	575	1000	906	85	42	42	577	583	602	594
263:13:14:13	575	971	891	88	40	40	577	582	605	581
263:13:15:13	574	944	563	54	68	68	580	588	614	603
263:13:16:13	574	970	531	53	68	68	580	589	612	617
263:13:17:13	574	973	500	52	70	70	580	588	612	614
263:13:18:13	575	968	500	53	70	70	581	593	612	616
263:13:19:13	575	968	500	52	72	72	580	591	612	619
263:13:20:13	574	984	578	61	69	69	580	590	608	614
263:13:21:13	574	990	688	67	62	62	579	590	611	614
263:13:22:12	574	993	641	64	63	63	581	593	615	614
263:13:23:12	574	1001	656	64	60	60	581	593	616	616
263:13:24:13	573	1002	656	64	62	62	580	589	616	610
263:13:25:13	574	999	641	64	62	62	581	593	617	611
263:13:26:13	573	997	641	63	62	62	580	593	616	618
263:13:27:13	573	999	609	60	65	65	581	589	616	608
263:13:28:13	573	1000	641	64	63	63	580	588	614	614
263:13:29:13	573	997	672	67	62	62	579	590	613	611
263:13:30:13	572	999	656	64	63	63	579	590	613	615
263:13:31:12	573	996	469	50	75	75	581	593	618	540
263:13:32:13	574	1005	578	60	68	68	581	589	614	562
263:13:33:13	573	1002	672	67	64	64	579	586	611	535
263:13:34:12	574	1003	688	67	63	63	580	584	612	521
263:13:35:13	573	991	672	66	61	61	579	588	611	593
263:13:36:13	573	995	656	64	61	61	580	589	617	583
263:13:37:13	573	1001	688	68	60	60	580	589	615	612
263:13:38:13	573	997	625	62	63	63	581	591	617	612
263:13:39:13	573	999	625	63	63	63	580	590	616	618
263:13:40:13	573	1003	656	64	62	62	580	591	615	617
263:13:41:13	573	1004	672	65	63	64	580	589	615	605
263:13:42:13	573	1009	625	63	64	64	580	592	615	612
263:13:43:13	573	1008	641	63	62	62	581	594	618	610
263:13:44:13	572	1009	641	64	62	62	580	593	617	615
263:13:45:13	573	1011	641	62	61	61	580	592	617	609
263:13:46:12	573	1010	625	63	63	63	580	592	617	614
263:13:47:13	574	1007	609	60	65	65	580	591	617	613
263:13:48:13	573	1010	609	61	65	65	581	593	617	613
263:13:49:13	574	1009	594	60	65	65	581	593	618	612
263:13:50:12	574	1013	625	62	63	63	581	593	617	606
263:13:51:12	573	1010	656	63	62	62	580	591	617	610

03

DAY 263 1984 DATA.7:00-17:00

TIME DAY:HR:MI:SE	TE101 DEG F	TE102 DEG F	FT101 100 LB/H	FD101 K/LBS	FCV101 PERCENT	FCV102 PERCENT	TE103 DEG F	TE104 DEG F	TE105 DEG F	TE106 DEG F
263:13:52:13	573	1010	609	60	65	65	580	590	617	611
263:13:53:13	573	1015	641	62	63	63	581	593	617	607
263:13:54:13	573	1016	609	60	64	64	581	590	618	608
263:13:55:12	573	1012	609	60	65	65	581	588	619	576
263:13:56:12	574	1016	625	61	66	66	581	593	616	605
263:13:57:13	573	1014	609	60	66	66	581	593	617	609
263:13:58:13	573	1021	625	61	65	65	580	591	616	600
263:13:59:13	574	1017	625	61	63	63	581	594	620	606
263:14:0:13	574	1015	563	57	67	67	582	593	621	600
263:14:1:13	573	1014	547	56	70	69	581	590	620	603
263:14:2:12	573	1018	563	57	69	69	581	591	616	608
263:14:3:13	573	1015	609	60	67	68	580	588	616	608
263:14:4:12	573	1020	594	60	68	68	581	587	616	608
263:14:5:13	573	1022	578	57	66	66	582	588	621	543
263:14:6:12	573	1024	609	61	64	64	581	587	621	522
263:14:7:13	574	1029	656	64	60	60	582	587	624	472
263:14:8:12	573	1021	609	61	65	65	582	589	621	507
263:14:9:13	573	1008	500	52	70	70	583	594	625	512
263:14:10:14	573	1018	656	64	62	62	581	592	617	593
263:14:11:12	573	1010	609	61	63	63	582	590	628	526
263:14:12:13	574	1021	578	60	66	66	581	589	620	605
263:14:13:12	575	1013	625	61	64	64	582	593	625	603
263:14:14:13	575	1032	625	59	64	61	584	589	632	477
263:14:15:12	575	1032	719	66	59	58	582	588	621	513
263:14:16:13	573	1012	641	61	62	62	582	589	625	483
263:14:17:13	575	1014	563	58	68	67	582	588	623	489
263:14:18:12	574	1017	516	56	70	70	582	589	619	553
263:14:19:13	574	1007	516	52	70	70	583	594	622	605
263:14:20:13	574	1009	469	50	73	73	583	591	620	607
263:14:21:12	573	1015	531	53	71	71	581	580	619	578
263:14:22:12	573	1021	500	52	70	70	582	592	621	583
263:14:23:12	573	1012	531	54	69	69	583	593	621	611
263:14:24:12	573	1016	578	56	67	67	582	595	625	593
263:14:25:13	573	1024	563	56	68	68	582	594	625	562
263:14:26:13	573	1015	578	57	68	69	581	592	618	608
263:14:27:13	573	1018	609	57	66	66	582	591	625	540
263:14:28:13	573	1028	641	61	65	65	581	590	618	575
263:14:29:13	573	1014	672	64	61	61	581	591	621	600
263:14:30:12	573	1017	625	60	66	66	580	592	618	618
263:14:31:12	575	1015	500	49	72	72	583	596	624	564
263:14:32:12	573	1018	422	45	76	76	583	598	619	616
263:14:33:13	573	1007	406	43	76	76	583	598	622	620
263:14:34:13	574	1017	438	46	75	75	584	597	624	617
263:14:35:12	573	1017	500	50	72	72	583	594	621	617
263:14:36:12	573	1022	516	52	70	70	582	590	621	609
263:14:37:13	575	1027	609	58	65	65	582	588	621	565
263:14:38:13	574	1026	734	70	58	58	580	586	619	600
263:14:39:12	575	1015	641	62	63	63	581	588	622	606
263:14:40:12	575	1023	641	61	64	64	582	590	621	616
263:14:41:13	575	1020	609	61	65	65	582	589	623	600
263:14:42:13	574	1020	625	60	65	65	582	591	619	621
263:14:43:13	575	1017	594	57	66	66	582	593	624	616
263:14:44:12	575	1023	563	54	66	65	583	598	627	606
263:14:45:13	574	1020	563	54	67	66	583	597	626	614
263:14:46:13	574	1017	516	52	69	69	583	598	625	616
263:14:47:13	573	1016	516	52	70	70	582	596	623	615

CA

TIME DAY:HR:MI:SE	TE101 DEG F	TE102 DEG F	FT101 100 LB/H	FD101 K/LBS	FCV101 PERCENT	FCV102 PERCENT	TE103 DEG F	TE104 DEG F	TE105 DEG F	TE106 DEG F
263:14:48:13	573	1020	516	53	71	71	582	595	621	612
263:14:49:12	573	1017	531	54	72	71	582	592	620	611
263:14:50:12	574	1019	531	53	70	71	582	595	620	613
263:14:51:12	575	1017	516	53	70	70	583	596	622	617
263:14:52:12	574	1021	563	56	70	70	582	595	620	610
263:14:53:12	574	1018	547	56	72	72	581	594	620	612
263:14:54:12	574	1018	563	56	70	70	582	595	620	616
263:14:55:14	574	1023	594	58	68	68	581	594	620	614
263:14:56:13	574	1020	578	56	68	68	582	595	622	618
263:14:57:13	574	1019	500	56	66	66	587	603	636	554
263:14:58:13	573	923	719	72	59	59	579	586	605	603
263:14:59:13	574	904	578	57	65	65	582	595	618	597
263:15:0:13	573	930	656	64	62	62	580	591	612	608
263:15:1:13	573	919	656	66	61	61	580	587	613	595
263:15:2:12	573	927	672	69	61	61	579	586	610	612
263:15:3:12	573	931	688	67	63	64	579	584	608	560
263:15:4:12	572	918	609	64	66	66	580	588	609	583
263:15:5:12	572	918	625	64	65	65	579	588	610	614
263:15:6:13	572	923	656	66	63	63	578	588	609	615
263:15:7:12	572	925	672	67	62	62	578	587	609	615
263:15:8:12	572	923	656	65	61	61	578	588	609	615
263:15:9:13	572	924	641	65	64	64	578	589	609	607
263:15:10:14	572	925	688	66	62	63	578	588	608	605
263:15:11:12	572	920	609	60	67	67	578	585	609	611
263:15:12:12	573	934	625	64	66	66	579	584	609	596
263:15:13:12	572	937	625	62	67	67	579	590	612	609
263:15:14:12	572	951	641	63	67	67	578	589	611	613
263:15:15:12	572	956	641	61	66	66	579	590	614	615
263:15:16:12	572	962	609	60	67	67	579	589	617	610
263:15:17:12	572	968	594	58	67	67	580	593	618	617
263:15:18:13	572	981	750	73	56	56	578	590	615	614
263:15:19:12	572	991	766	74	56	56	578	586	619	541
263:15:20:12	573	987	656	66	63	63	579	588	619	548
263:15:21:12	572	984	719	69	59	60	578	587	617	592
263:15:22:13	572	985	688	66	61	61	578	589	615	616
263:15:23:12	573	996	578	58	66	66	580	591	621	573
263:15:24:13	572	1006	703	67	60	60	579	589	622	535
263:15:25:13	572	994	672	66	61	61	579	590	620	370
263:15:26:12	572	991	641	62	64	64	579	592	618	608
263:15:27:12	572	997	641	62	64	64	578	591	617	615
263:15:28:12	572	1003	656	63	64	64	578	589	615	614
263:15:29:12	572	1003	656	64	63	63	577	583	615	600
263:15:30:12	571	1005	688	66	63	63	577	583	614	581
263:15:31:13	571	997	594	62	68	68	578	588	613	613
263:15:32:13	572	1001	594	61	68	68	579	590	615	614
263:15:33:12	571	999	609	59	68	68	578	591	616	615
263:15:34:12	572	1002	625	62	66	66	578	591	616	615
263:15:35:13	572	1001	656	63	63	63	578	589	617	618
263:15:36:12	571	1003	609	60	65	65	578	586	618	598
263:15:37:12	571	1000	563	56	68	68	578	587	617	590
263:15:38:13	571	997	578	59	69	69	577	589	611	606
263:15:39:13	571	997	531	54	72	72	578	590	613	607
263:15:40:13	571	1001	531	53	71	71	578	589	613	590
263:15:41:12	571	1002	484	52	72	72	578	591	613	592
263:15:42:13	571	999	531	57	70	70	578	590	613	594
263:15:43:13	571	999	547	55	71	71	578	589	613	598

C-5

DAY 263 1984 DATA.7:00-17:00

TIME DAY:HR:MI:SE	TE101 DEC F	TE102 DEC F	FT101 100 LB/H	FD101 K/LBS	FCV101 PERCENT	FCV102 PERCENT	TE103 DEC F	TE104 DEC F	TE105 DEC F	TE106 DEC F
263:15:44:14	571	999	563	57	70	70	578	588	614	599
263:15:45:13	571	1001	594	58	68	68	578	589	616	593
263:15:46:13	571	1001	594	57	66	66	578	589	617	585
263:15:47:13	571	1000	578	57	66	66	578	590	617	595
263:15:48:13	572	1000	578	56	66	66	579	589	620	598
263:15:49:13	572	998	578	57	66	66	579	593	620	600
263:15:50:12	572	998	547	54	69	69	579	586	618	582
263:15:51:12	571	1001	625	60	67	67	577	588	614	602
263:15:52:13	571	999	625	60	66	66	578	588	617	605
263:15:53:12	572	999	547	54	68	68	579	591	620	604
263:15:54:13	572	1000	516	52	69	68	580	594	622	598
263:15:55:12	571	997	500	50	70	70	579	594	622	585
263:15:56:13	571	999	500	50	70	70	579	593	621	588
263:15:57:12	571	995	484	50	73	73	579	593	618	596
263:15:58:13	572	996	453	47	73	73	580	594	620	594
263:15:59:12	572	1000	469	49	73	73	579	593	620	583
263:16: 0:12	571	1000	469	49	73	73	578	591	616	582
263:16: 1:12	571	1000	500	52	71	71	578	591	618	576
263:16: 2:13	571	999	484	49	71	71	579	593	621	572
263:16: 3:13	571	996	469	49	72	72	579	594	621	588
263:16: 4:13	571	993	453	47	74	74	579	593	620	598
263:16: 5:13	571	995	438	46	75	75	579	591	617	602
263:16: 6:13	571	1000	453	46	74	74	578	593	618	597
263:16: 7:13	571	959	313	30	84	84	569	568	571	591
263:16: 8:12	570	815	313	30	83	83	568	566	568	574
263:16: 9:13	569	662	297	30	85	85	568	566	567	569
263:16:10:13	571	589	313	30	85	84	569	568	569	569
263:16:11:13	570	571	625	59	67	67	568	567	568	568
263:16:12:13	570	571	609	60	68	69	569	568	569	569
263:16:13:13	571	573	609	60	68	68	569	568	568	569
263:16:14:13	571	573	594	60	68	68	569	569	569	569
263:16:15:13	571	572	609	60	66	66	569	568	569	568
263:16:16:13	571	572	609	60	66	67	569	568	569	569
263:16:17:13	571	572	297	31	86	86	568	568	569	569
263:16:18:12	572	575	0	30	98	99	568	568	569	569
263:16:19:13	571	573	0	30	98	99	568	566	569	568
263:16:20:13	571	575	0	30	98	99	568	566	569	566
263:16:21:12	574	577	0	30	95	95	568	566	570	567
263:16:22:12	574	580	0	30	95	95	568	564	570	566
263:16:23:13	575	582	0	30	0	0	568	564	570	566
263:16:24:13	575	584	0	30	0	0	569	563	570	565
263:16:25:11	575	586	0	30	0	0	569	562	570	565
263:16:26:13	575	588	0	30	0	0	569	560	570	564
263:16:27:12	575	589	0	30	0	0	568	546	569	558
263:16:28:13	575	591	0	30	0	0	565	529	566	545
263:16:29:13	576	594	0	30	0	0	563	522	563	536
263:16:30:13	578	595	0	30	0	0	562	518	562	532
263:16:31:13	579	597	0	30	0	0	560	517	561	529
263:16:32:12	579	598	0	30	0	0	558	515	558	528
263:16:33:13	581	600	0	30	0	0	557	514	557	526
263:16:34:12	582	601	0	30	0	0	556	514	556	525
263:16:35:12	583	603	0	30	0	0	555	513	555	525
263:16:36:12	585	604	0	30	0	0	555	513	555	525
263:16:37:12	585	604	0	30	0	0	553	512	553	524
263:16:38:12	587	606	0	30	0	0	553	511	553	524
263:16:39:11	588	606	0	30	0	0	551	511	551	523

6

## DAY 263 1984 DATA.7:00-17:00

TIME DAY:HR:MI:SE	TE107 DEC F	TE108 DEC F	TE109 DEC F	TE110 DEC F	TE111 DEC F	TE112 DEC F	TE113 DEC F	TE114 DEC F	TE115 DEC F	TE116 DEC F
263:12: 0:13	579	578	579	579	580	573	580	578	579	576
263:12: 1:13	579	578	579	579	580	573	580	578	579	576
263:12: 2:14	579	579	579	579	580	573	580	578	579	576
263:12: 3:13	579	578	578	578	580	573	579	576	579	576
263:12: 4:13	578	578	578	578	580	573	579	576	579	576
263:12: 5:13	575	575	575	574	576	571	575	572	575	572
263:12: 6:13	575	573	572	572	574	569	571	569	571	568
263:12: 7:14	590	590	589	583	581	574	585	585	580	583
263:12: 8:13	639	648	662	670	681	613	708	729	700	714
263:12: 9:13	658	678	713	732	773	648	831	855	858	889
263:12:10:13	635	648	672	681	714	719	761	778	806	825
263:12:11:13	652	669	695	711	742	714	796	817	831	855
263:12:12:13	649	666	693	709	745	744	800	820	849	872
263:12:13:14	650	669	696	712	749	720	803	824	849	871
263:12:14:13	658	678	708	726	764	734	822	844	869	894
263:12:15:14	656	676	706	722	763	728	822	842	872	895
263:12:16:13	657	675	708	725	766	687	827	849	879	903
263:12:17:13	656	674	705	722	761	738	823	845	876	899
263:12:18:13	658	678	711	725	770	684	834	857	889	911
263:12:19:13	645	661	695	710	766	647	831	851	897	913
263:12:20:13	650	669	702	720	766	677	830	851	888	908
263:12:21:13	664	683	720	733	778	653	841	862	892	914
263:12:22:13	654	672	708	719	773	626	838	860	900	922
263:12:23:13	654	672	706	717	768	666	829	851	887	909
263:12:24:13	654	671	705	719	765	712	827	849	883	905
263:12:25:13	648	666	699	714	766	723	829	851	893	913
263:12:26:13	650	668	700	716	763	729	825	847	885	905
263:12:27:12	653	673	705	725	770	757	832	853	890	911
263:12:28:13	654	676	709	729	773	768	835	857	892	913
263:12:29:13	656	678	711	731	773	765	837	858	893	916
263:12:30:12	656	677	709	729	771	757	834	856	891	911
263:12:31:13	654	675	706	725	770	759	833	854	891	912
263:12:32:13	656	678	709	727	773	753	836	857	893	915
263:12:33:12	653	673	705	724	768	758	830	851	889	909
263:12:34:14	655	677	708	729	772	758	834	855	891	910
263:12:35:13	656	678	709	728	773	757	835	856	894	915
263:12:36:13	654	677	709	728	776	749	841	861	903	923
263:12:37:13	659	680	715	733	782	690	846	866	905	926
263:12:38:12	654	674	707	726	770	754	832	852	893	911
263:12:39:13	660	682	716	736	782	757	848	869	907	928
263:12:40:13	661	683	717	738	782	759	846	866	906	926
263:12:41:12	661	683	719	740	786	758	852	873	914	934
263:12:42:13	662	685	719	740	785	752	850	871	910	931
263:12:43:13	665	687	721	740	786	748	849	871	908	929
263:12:44:12	661	684	723	742	797	653	866	886	930	951
263:12:45:13	662	683	720	737	784	649	849	869	907	927
263:12:46:13	663	683	720	736	783	653	851	871	909	930
263:12:47:13	660	681	717	733	784	657	852	873	916	937
263:12:48:14	660	681	715	733	775	750	838	859	896	916
263:12:49:13	659	679	719	733	790	698	857	872	918	938
263:12:50:13	647	666	700	716	776	733	845	862	916	932
263:12:51:13	657	678	715	733	782	727	847	867	905	924
263:12:52:13	666	689	728	749	799	680	868	890	926	949
263:12:53:13	666	686	722	735	782	664	844	865	901	920
263:12:54:13	662	681	720	736	783	675	849	871	912	934
263:12:55:13	666	686	724	737	791	639	858	879	919	940

C7

DAY 263 1984 DATA.7:00-17:00

TIME DAY:HR:MI:SE	TE107 DEC F	TE108 DEC F	TE109 DEC F	TE110 DEC F	TE111 DEC F	TE112 DEC F	TE113 DEC F	TE114 DEC F	TE115 DEC F	TE116 DEC F
263:12:56:13	658	678	716	732	783	649	848	866	908	927
263:12:57:13	655	674	707	721	767	721	827	847	887	905
263:12:58:13	652	671	703	716	763	729	825	846	885	904
263:12:59:12	647	665	696	713	763	758	827	846	889	908
263:13:0:12	651	672	703	721	768	770	829	846	887	903
263:13:1:13	653	675	708	729	773	765	834	853	892	912
263:13:2:13	656	678	711	730	774	763	836	855	895	915
263:13:3:14	659	681	712	730	773	757	837	858	895	916
263:13:4:13	659	681	712	732	773	754	835	856	892	913
263:13:5:13	657	678	709	730	771	751	836	857	894	915
263:13:6:13	657	679	709	728	772	753	837	856	894	915
263:13:7:12	660	682	713	732	774	752	838	859	896	916
263:13:8:13	659	680	711	729	770	745	834	854	891	913
263:13:9:13	658	680	711	729	773	743	838	860	895	917
263:13:10:13	659	681	714	733	774	732	838	858	895	916
263:13:11:12	663	687	721	741	790	700	859	881	916	938
263:13:12:13	654	675	708	725	773	736	837	856	901	920
263:13:13:13	637	658	692	709	761	748	813	824	884	893
263:13:14:13	644	665	699	716	765	725	817	830	872	879
263:13:15:13	659	680	708	723	758	726	810	828	853	871
263:13:16:13	656	677	706	722	765	752	828	849	884	905
263:13:17:13	654	674	701	716	757	743	819	839	873	893
263:13:18:13	655	675	704	721	760	753	820	839	872	891
263:13:19:13	654	674	703	720	761	754	823	845	878	898
263:13:20:13	647	666	695	715	759	752	822	842	881	899
263:13:21:13	651	673	704	721	769	752	832	852	891	908
263:13:22:12	661	683	716	737	781	757	842	862	896	915
263:13:23:12	661	684	717	738	781	761	844	865	902	921
263:13:24:13	663	687	719	736	782	749	845	865	902	922
263:13:25:13	662	686	718	739	781	752	844	865	901	920
263:13:26:13	662	687	717	737	779	761	842	862	899	920
263:13:27:13	662	687	717	735	781	747	844	865	902	922
263:13:28:13	659	682	712	730	774	749	838	858	898	917
263:13:29:13	656	677	709	730	776	756	840	861	901	918
263:13:30:13	658	681	714	735	779	761	842	861	900	918
263:13:31:12	666	687	722	740	785	653	851	872	906	924
263:13:32:13	656	677	708	719	769	693	834	856	898	917
263:13:33:13	653	674	708	727	779	654	845	864	907	924
263:13:34:12	654	674	709	726	778	646	841	859	902	918
263:13:35:13	654	674	707	725	772	742	833	853	892	909
263:13:36:13	666	689	725	745	791	733	854	875	907	927
263:13:37:13	658	680	714	733	778	766	839	859	899	918
263:13:38:13	664	687	721	741	785	762	848	868	904	923
263:13:39:13	662	685	716	734	779	765	842	863	902	920
263:13:40:13	659	682	716	736	782	770	846	866	906	925
263:13:41:13	660	684	717	739	784	765	847	866	906	924
263:13:42:13	662	686	721	744	789	765	853	873	911	930
263:13:43:13	666	690	724	744	788	765	853	874	913	931
263:13:44:13	666	689	723	745	788	768	852	872	911	931
263:13:45:13	665	689	724	746	790	758	856	876	916	934
263:13:46:12	664	688	721	743	787	764	852	871	910	929
263:13:47:13	665	690	723	744	789	761	853	875	912	931
263:13:48:13	664	687	720	740	785	764	849	870	909	929
263:13:49:13	666	690	723	740	787	751	853	874	912	932
263:13:50:12	665	688	721	742	787	755	852	872	912	931
263:13:51:12	665	689	720	741	788	753	855	875	916	934

CG

TIME DAY:HR:MI:SE	TE107 DEC F	TE108 DEC F	TE109 DEC F	TE110 DEC F	TE111 DEC F	TE112 DEC F	TE113 DEC F	TE114 DEC F	TE115 DEC F	TE116 DEC F
263:13:52:13	665	690	723	745	786	761	851	871	909	928
263:13:53:13	665	689	724	745	792	753	858	879	919	938
263:13:54:13	666	691	723	741	789	750	855	876	915	934
263:13:55:12	667	693	725	742	791	745	857	878	916	936
263:13:56:12	661	684	717	739	784	755	848	869	911	929
263:13:57:13	665	688	722	742	791	757	856	877	917	936
263:13:58:13	663	688	723	745	791	758	857	878	919	938
263:13:59:13	667	692	727	748	793	754	859	881	921	939
263:14:0:13	671	696	729	751	793	758	860	881	918	938
263:14:1:13	669	693	726	744	789	752	855	878	918	939
263:14:2:12	662	686	720	737	786	751	853	874	915	935
263:14:3:13	661	687	719	737	787	754	854	875	916	935
263:14:4:12	662	687	720	739	791	750	857	878	919	938
263:14:5:13	671	698	732	749	801	747	868	891	927	948
263:14:6:12	670	695	729	746	794	726	859	881	921	941
263:14:7:13	678	704	744	762	814	634	882	902	941	963
263:14:8:12	671	694	729	742	789	647	852	871	914	933
263:14:9:13	677	699	736	754	800	643	866	888	923	944
263:14:10:14	663	687	720	740	786	748	852	872	917	936
263:14:11:12	683	708	747	766	813	720	879	901	929	953
263:14:12:13	670	694	727	745	789	753	852	874	916	936
263:14:13:12	675	701	733	753	801	763	866	888	924	944
263:14:14:13	690	715	755	770	823	646	891	912	947	968
263:14:15:12	671	694	731	746	797	668	861	881	927	947
263:14:16:13	679	702	740	753	802	716	865	885	921	941
263:14:17:13	674	697	733	749	796	724	859	881	919	939
263:14:18:12	669	692	727	744	793	744	858	880	920	940
263:14:19:13	671	694	726	742	788	755	853	877	913	934
263:14:20:13	667	690	723	739	787	751	853	876	913	934
263:14:21:12	668	693	727	744	794	747	861	884	920	941
263:14:22:12	670	694	729	747	796	747	862	887	921	943
263:14:23:12	671	694	727	745	790	771	856	879	916	935
263:14:24:12	676	700	737	756	805	744	871	893	927	948
263:14:25:13	678	702	739	759	806	713	874	897	932	953
263:14:26:13	667	689	722	741	786	779	849	871	911	930
263:14:27:13	681	707	747	766	817	688	885	906	939	960
263:14:28:13	666	687	724	742	790	730	853	872	918	936
263:14:29:13	667	692	729	750	801	766	866	886	924	943
263:14:30:12	669	694	730	751	797	786	859	878	918	936
263:14:31:12	677	702	740	761	806	728	872	894	928	949
263:14:32:12	666	687	725	746	788	782	855	878	917	937
263:14:33:13	672	696	730	752	795	780	862	885	917	941
263:14:34:13	674	698	730	751	795	781	863	887	922	943
263:14:35:12	669	693	725	746	793	780	861	884	923	943
263:14:36:12	671	696	732	749	800	759	867	889	926	946
263:14:37:13	671	698	733	750	803	753	869	889	929	948
263:14:38:13	670	690	726	747	799	765	862	879	925	941
263:14:39:12	675	704	740	757	805	751	865	884	921	940
263:14:40:12	669	696	732	751	800	761	864	883	925	944
263:14:41:13	674	702	737	754	805	756	869	888	926	944
263:14:42:13	669	695	730	751	799	783	862	881	921	939
263:14:43:13	677	701	737	759	805	779	870	889	926	945
263:14:44:12	682	708	745	765	810	775	874	895	931	953
263:14:45:13	679	705	740	761	803	770	868	889	925	945
263:14:46:13	677	701	737	758	800	781	863	885	922	943
263:14:47:13	674	700	733	753	799	777	865	888	925	945



DAY 263 1984 DATA.7:00-17:00

TIME DAY:HR:MI:SE	TE107 DEC F	TE108 DEC F	TE109 DEC F	TE110 DEC F	TE111 DEC F	TE112 DEC F	TE113 DEC F	TE114 DEC F	TE115 DEC F	TE116 DEC F
263:14:48:13	671	695	729	748	796	771	861	882	922	942
263:14:49:12	668	694	728	750	796	773	860	881	919	938
263:14:50:12	669	693	728	752	798	778	862	883	921	940
263:14:51:12	673	699	733	756	801	783	865	886	922	941
263:14:52:12	670	695	731	753	799	780	863	884	923	942
263:14:53:12	669	694	729	750	798	776	861	881	921	939
263:14:54:12	670	696	730	753	799	782	863	884	924	943
263:14:55:14	670	695	732	756	803	783	866	887	925	944
263:14:56:13	674	702	737	760	805	784	867	887	925	944
263:14:57:13	697	724	762	779	827	733	893	913	944	966
263:14:58:13	638	654	677	687	722	747	765	774	820	822
263:14:59:13	662	683	714	733	769	728	821	837	859	873
263:15:0:13	651	670	698	713	749	733	801	816	851	862
263:15:1:13	654	675	703	719	757	726	806	821	853	865
263:15:2:12	649	671	697	709	751	740	802	818	853	866
263:15:3:12	647	666	695	709	753	674	805	820	855	867
263:15:4:12	648	666	692	706	744	722	793	810	844	856
263:15:5:12	649	669	695	712	749	750	799	816	847	861
263:15:6:13	649	669	696	713	750	749	801	817	851	865
263:15:7:12	648	669	696	711	751	749	801	817	851	863
263:15:8:12	650	670	698	713	752	748	803	819	852	865
263:15:9:13	649	669	696	713	750	733	801	816	849	862
263:15:10:14	647	667	694	710	750	729	802	818	852	865
263:15:11:12	650	671	697	711	750	740	799	817	847	861
263:15:12:12	649	671	698	713	756	744	810	826	860	874
263:15:13:12	654	675	704	723	763	744	817	834	865	879
263:15:14:12	654	675	707	725	769	756	824	841	874	888
263:15:15:12	659	683	715	736	777	761	832	849	880	895
263:15:16:12	665	689	720	739	779	761	835	854	887	903
263:15:17:12	666	690	722	741	781	768	838	857	891	908
263:15:18:13	665	691	725	746	793	768	852	871	906	923
263:15:19:12	674	700	740	753	803	660	859	875	911	930
263:15:20:12	669	692	727	743	786	696	844	863	898	915
263:15:21:12	662	687	723	741	788	747	847	865	903	920
263:15:22:13	665	691	725	746	789	770	847	865	900	917
263:15:23:12	675	701	738	757	803	742	864	884	916	936
263:15:24:13	671	696	734	752	800	683	862	881	920	938
263:15:25:13	674	699	735	753	797	717	857	875	911	929
263:15:26:12	668	693	728	747	791	773	851	870	907	924
263:15:27:12	669	694	730	753	795	779	858	877	915	933
263:15:28:12	665	690	726	747	793	781	855	874	915	932
263:15:29:12	662	689	725	742	795	758	857	876	917	934
263:15:30:12	663	689	724	740	793	753	852	870	911	927
263:15:31:13	659	684	717	737	785	775	847	866	905	920
263:15:32:13	663	688	723	744	791	771	855	875	913	930
263:15:33:12	667	692	726	748	794	777	857	877	913	930
263:15:34:12	667	692	726	747	793	770	857	877	916	934
263:15:35:13	668	695	726	745	795	778	858	877	916	932
263:15:36:12	671	700	734	750	800	756	863	883	919	938
263:15:37:12	669	695	728	745	792	752	853	873	911	929
263:15:38:13	657	681	715	736	783	771	847	867	909	925
263:15:39:13	661	684	719	740	787	771	851	872	909	926
263:15:40:13	662	684	720	740	788	754	852	872	913	928
263:15:41:12	660	683	717	739	786	750	851	872	911	927
263:15:42:13	661	685	719	738	785	750	850	870	909	925
263:15:43:13	661	685	718	736	785	751	849	871	910	926

C-10

TIME DAY:HR:MI:SE	TE107 DEC F	TE108 DEC F	TE109 DEC F	TE110 DEC F	TE111 DEC F	TE112 DEC F	TE113 DEC F	TE114 DEC F	TE115 DEC F	TE116 DEC F
263:15:44:14	662	687	720	741	789	756	852	873	911	927
263:15:45:13	665	690	726	747	793	747	857	876	916	931
263:15:46:13	669	694	729	750	796	746	859	878	918	933
263:15:47:13	670	694	730	750	796	751	859	878	917	934
263:15:48:13	672	699	733	748	797	751	859	879	917	935
263:15:49:13	672	697	732	749	795	754	858	878	917	934
263:15:50:12	670	698	730	746	795	747	858	878	916	934
263:15:51:12	663	688	722	740	790	758	853	873	916	932
263:15:52:13	669	693	728	745	795	759	856	875	915	931
263:15:53:12	674	700	735	751	798	755	861	881	918	935
263:15:54:13	675	702	736	753	798	754	861	882	919	938
263:15:55:12	676	702	735	756	798	748	863	883	920	936
263:15:56:13	672	698	732	753	796	749	861	882	920	937
263:15:57:12	670	693	728	750	792	760	855	876	913	931
263:15:58:13	672	695	730	752	795	758	861	883	918	936
263:15:59:12	670	695	728	748	793	749	858	879	917	934
263:16: 0:12	666	690	724	745	792	745	856	877	916	931
263:16: 1:12	670	694	729	749	795	738	859	879	916	932
263:16: 2:13	674	700	734	754	799	736	863	884	919	935
263:16: 3:13	671	696	729	748	793	745	858	879	916	933
263:16: 4:13	672	698	730	751	793	753	858	878	914	931
263:16: 5:13	671	696	728	749	793	768	859	881	917	935
263:16: 6:13	669	694	727	744	793	756	859	881	917	935
263:16: 7:13	582	595	617	634	716	756	737	750	816	821
263:16: 8:12	568	570	570	571	615	673	608	609	672	667
263:16: 9:13	565	568	566	564	588	629	575	569	599	585
263:16:10:13	567	569	568	566	582	608	571	565	586	572
263:16:11:13	567	569	568	566	580	596	571	565	581	569
263:16:12:13	568	571	569	569	580	592	573	568	582	572
263:16:13:13	568	571	569	568	579	588	572	567	580	571
263:16:14:13	568	571	569	569	578	586	572	567	580	571
263:16:15:13	568	571	568	568	577	583	571	567	578	570
263:16:16:13	568	571	569	568	576	581	571	567	578	570
263:16:17:13	568	571	568	568	576	580	571	568	577	570
263:16:18:12	569	569	569	568	576	579	572	568	579	572
263:16:19:13	569	569	570	567	577	578	574	568	580	572
263:16:20:13	569	568	571	568	578	577	576	569	582	573
263:16:21:12	571	566	573	568	580	577	578	569	585	575
263:16:22:12	571	564	572	567	580	576	579	569	586	575
263:16:23:13	571	562	573	566	581	575	581	569	587	575
263:16:24:13	571	561	573	566	581	575	581	568	588	575
263:16:25:11	572	560	574	565	582	574	582	568	589	575
263:16:26:13	572	556	575	563	582	573	583	566	589	575
263:16:27:12	570	540	572	543	580	568	580	548	588	560
263:16:28:13	566	524	569	526	578	556	577	531	585	543
263:16:29:13	564	517	565	518	575	545	575	525	582	536
263:16:30:13	562	514	563	515	572	538	572	522	580	534
263:16:31:13	560	511	562	514	570	536	570	522	578	533
263:16:32:12	558	510	560	512	568	533	569	521	576	533
263:16:33:13	557	509	558	511	566	532	568	521	575	532
263:16:34:12	556	507	557	511	565	531	566	520	574	533
263:16:35:12	555	507	556	511	564	531	565	521	573	532
263:16:36:12	554	506	555	511	564	531	565	521	572	533
263:16:37:12	553	505	554	510	562	530	563	521	571	532
263:16:38:12	552	505	553	510	562	530	562	521	569	533
263:16:39:11	550	503	551	510	560	529	561	520	568	532

C-11

## DAY 263 1984 DATA.7:00-17:00

TIME DAY:HR:MI:SE	TE117 DEG F	TE118 DEG F	TE119 DEG F	TE120 DEG F	LT151 INCH	FCV151 PERCENT	LT161A INCH	PT181 PSI	PT182 PSI	TE131 DEG F
263:12:0:13	579	577	579	576	82	100	20	17	141	500
263:12:1:13	579	577	579	576	82	100	20	17	142	580
263:12:2:14	579	577	579	575	82	100	20	18	142	500
263:12:3:13	578	576	578	575	82	100	20	18	141	580
263:12:4:13	578	576	578	575	82	100	20	17	142	500
263:12:5:13	574	572	575	573	82	100	20	17	141	579
263:12:6:13	569	568	570	570	82	100	20	17	142	580
263:12:7:14	591	589	587	574	82	100	20	18	142	580
263:12:8:13	736	694	690	613	82	100	20	18	142	584
263:12:9:13	918	901	902	761	80	100	23	53	124	587
263:12:10:13	853	866	895	867	79	100	21	56	111	585
263:12:11:13	895	895	908	874	80	100	16	43	123	506
263:12:12:13	904	915	934	909	78	100	16	61	110	586
263:12:13:14	904	913	931	915	78	100	23	60	110	586
263:12:14:13	926	936	952	931	78	100	20	60	115	586
263:12:15:14	928	940	961	945	79	100	21	55	115	585
263:12:16:13	938	940	968	952	79	100	19	40	118	585
263:12:17:13	935	938	969	955	79	100	21	40	121	583
263:12:18:13	948	944	977	958	79	100	20	38	122	583
263:12:19:13	949	950	993	976	79	100	16	41	116	582
263:12:20:13	941	948	980	971	79	100	20	47	117	582
263:12:21:13	952	948	980	964	79	100	22	47	125	582
263:12:22:13	957	963	995	979	79	100	19	51	119	581
263:12:23:13	944	951	983	978	79	100	22	56	117	581
263:12:24:13	938	947	971	969	79	100	18	44	119	581
263:12:25:13	947	960	987	981	78	100	20	47	115	581
263:12:26:13	937	950	975	977	78	100	19	48	116	580
263:12:27:12	944	957	981	978	78	100	21	52	117	580
263:12:28:13	946	959	982	980	78	100	21	52	118	579
263:12:29:13	949	962	986	982	78	100	20	47	120	579
263:12:30:12	947	959	984	983	78	100	21	45	120	580
263:12:31:13	947	957	984	983	78	100	21	51	118	580
263:12:32:13	949	962	986	984	78	100	20	49	119	579
263:12:33:12	944	958	984	984	78	100	19	46	119	580
263:12:34:14	944	958	983	983	78	100	20	48	119	580
263:12:35:13	950	963	987	985	78	100	21	49	119	580
263:12:36:13	957	970	998	995	77	100	19	67	110	580
263:12:37:13	959	963	997	982	77	100	21	67	112	580
263:12:38:12	945	959	989	987	77	100	19	59	110	580
263:12:39:13	963	974	1000	991	77	100	20	62	111	580
263:12:40:13	961	973	1001	995	77	100	21	60	112	580
263:12:41:12	969	983	1009	1003	77	100	19	61	113	580
263:12:42:13	967	981	1006	1004	77	100	22	61	113	581
263:12:43:13	965	971	1003	999	77	100	21	58	114	580
263:12:44:12	986	989	1025	1009	77	100	20	74	110	581
263:12:45:13	962	964	1001	995	77	100	21	61	113	580
263:12:46:13	965	966	1004	991	77	100	19	57	114	580
263:12:47:13	972	977	1013	999	77	100	22	63	111	580
263:12:48:14	950	958	991	990	77	100	21	58	111	580
263:12:49:13	971	977	1011	993	77	100	19	58	111	580
263:12:50:13	964	980	1016	1013	76	100	16	69	104	580
263:12:51:13	957	961	992	987	76	100	20	59	110	580
263:12:52:13	981	984	1019	1002	77	100	21	73	112	581
263:12:53:13	956	957	995	992	77	100	19	50	115	580
263:12:54:13	971	971	1010	999	77	100	21	54	115	580
263:12:55:13	973	980	1012	1003	76	100	22	66	114	580

C-12

TIME DAY:HR:MI:SE	TE117 DEG F	TE118 DEG F	TE119 DEG F	TE120 DEG F	LT151 INCH	FCV151 PERCENT	LT161A INCH	PT181 PSI	PT182 PSI	TE131 DEG F
263:12:56:13	960	965	1004	1001	76	100	20	63	111	500
263:12:57:13	938	949	979	985	77	100	19	46	118	580
263:12:58:13	937	945	979	981	77	100	21	31	124	500
263:12:59:12	939	955	983	986	77	100	18	41	121	580
263:13:0:12	935	951	980	986	77	100	19	42	122	580
263:13:1:13	944	958	984	985	77	100	19	36	125	580
263:13:2:13	949	965	991	991	78	100	20	42	125	580
263:13:3:14	949	964	989	990	78	100	21	39	127	580
263:13:4:13	948	962	987	987	78	100	21	35	129	500
263:13:5:13	949	962	985	987	78	100	21	34	128	500
263:13:6:13	949	963	989	989	78	100	21	36	127	581
263:13:7:12	950	963	986	987	78	100	22	38	127	581
263:13:8:13	949	963	989	989	78	100	21	33	128	500
263:13:9:13	951	964	987	990	78	100	20	32	128	581
263:13:10:13	952	955	987	987	78	100	20	29	131	580
263:13:11:12	971	969	1004	991	78	100	22	41	129	581
263:13:12:13	954	965	1001	999	77	100	21	47	123	581
263:13:13:13	919	935	978	985	76	100	24	74	107	581
263:13:14:13	904	915	954	960	76	100	28	88	108	580
263:13:15:13	902	907	935	941	77	100	26	41	126	581
263:13:16:13	938	949	968	957	77	100	20	41	127	580
263:13:17:13	929	940	963	965	77	100	20	37	127	580
263:13:18:13	924	935	958	962	77	100	22	36	127	581
263:13:19:13	930	934	960	961	77	100	20	33	127	581
263:13:20:13	933	945	971	970	77	100	18	38	123	581
263:13:21:13	940	950	975	977	76	100	21	52	116	581
263:13:22:12	949	958	982	980	76	100	21	49	119	581
263:13:23:12	954	966	990	986	76	100	21	54	119	581
263:13:24:13	955	967	991	989	76	100	20	52	120	581
263:13:25:13	953	964	988	988	76	100	20	53	120	581
263:13:26:13	953	963	988	986	76	100	21	51	120	581
263:13:27:13	955	967	990	988	76	100	20	48	121	581
263:13:28:13	950	963	987	989	76	100	21	49	118	581
263:13:29:13	950	962	985	987	76	100	19	52	117	580
263:13:30:13	951	962	987	987	76	100	20	49	118	580
263:13:31:12	959	955	987	980	76	100	19	28	127	581
263:13:32:13	952	955	991	989	76	100	21	40	121	581
263:13:33:13	955	951	990	986	76	100	20	47	118	581
263:13:34:12	949	951	989	988	76	100	19	50	117	581
263:13:35:13	940	946	977	982	76	100	19	53	116	580
263:13:36:13	959	960	989	981	76	100	22	56	122	581
263:13:37:13	949	957	987	987	76	100	19	56	118	581
263:13:38:13	956	967	989	986	76	100	21	51	121	582
263:13:39:13	953	964	987	988	76	100	21	49	120	581
263:13:40:13	957	967	993	991	76	100	20	52	119	580
263:13:41:13	956	964	992	992	76	100	20	49	119	581
263:13:42:13	964	975	999	995	76	100	19	49	120	581
263:13:43:13	965	975	997	996	76	100	22	54	122	581
263:13:44:13	963	974	999	997	76	100	20	52	121	581
263:13:45:13	968	979	1002	998	76	100	22	51	121	581
263:13:46:12	961	973	999	999	76	100	20	49	120	582
263:13:47:13	965	976	999	997	76	100	20	45	122	582
263:13:48:13	963	973	999	1000	76	100	20	46	121	582
263:13:49:13	966	977	999	998	76	100	21	46	122	582
263:13:50:12	966	978	1003	1001	76	100	21	49	121	582
263:13:51:12	967	978	1001	1000	76	100	20	51	120	581

C13

100

DAY 263 1984 DATA.7:00-17:00

TIME DAY:HR:MI:SE	TE117 DEG F	TE118 DEG F	TE119 DEG F	TE120 DEG F	LT151 INCH	FCV151 PERCENT	LT161A INCH	PT181 PSI	PT182 PSI	TE131 DEG F
263:12: 0:13	579	577	579	576	82	100	20	17	141	580
263:12: 1:13	579	577	579	576	82	100	20	17	142	580
263:12: 2:14	579	577	579	575	82	100	20	18	142	580
263:12: 3:13	578	576	578	575	82	100	20	18	141	580
263:12: 4:13	578	576	578	575	82	100	20	17	142	580
263:12: 5:13	574	572	575	573	82	100	20	17	141	579
263:12: 6:13	569	568	570	570	82	100	20	17	142	580
263:12: 7:14	591	589	587	574	82	100	20	18	142	580
263:12: 8:13	736	694	690	613	82	100	20	18	142	584
263:12: 9:13	918	901	902	761	80	100	23	53	124	587
263:12:10:13	853	866	895	867	79	100	21	56	111	585
263:12:11:13	895	895	908	874	80	100	16	43	123	586
263:12:12:13	904	915	934	909	78	100	16	61	110	586
263:12:13:14	904	913	931	915	78	100	23	60	110	586
263:12:14:13	926	936	952	931	78	100	20	60	115	586
263:12:15:14	928	940	961	945	79	100	21	55	115	585
263:12:16:13	938	940	968	952	79	100	19	40	118	585
263:12:17:13	935	938	969	955	79	100	21	40	121	583
263:12:18:13	948	944	977	958	79	100	20	38	122	583
263:12:19:13	949	950	993	976	79	100	16	41	116	582
263:12:20:13	941	948	980	971	79	100	20	47	117	582
263:12:21:13	952	948	980	964	79	100	22	47	125	582
263:12:22:13	957	963	995	979	79	100	19	51	119	581
263:12:23:13	944	951	983	978	79	100	22	56	117	581
263:12:24:13	938	947	971	969	79	100	18	44	119	581
263:12:25:13	947	960	987	981	78	100	20	47	115	581
263:12:26:13	937	950	975	977	78	100	19	48	116	580
263:12:27:12	944	957	981	978	78	100	21	52	117	580
263:12:28:13	946	959	982	980	78	100	21	52	118	579
263:12:29:13	949	962	986	982	78	100	20	47	120	579
263:12:30:12	947	959	984	983	78	100	21	45	120	580
263:12:31:13	947	957	984	983	78	100	21	51	118	580
263:12:32:13	949	962	986	984	78	100	20	49	119	579
263:12:33:12	944	958	984	984	78	100	19	46	119	580
263:12:34:14	944	958	983	983	78	100	20	48	119	580
263:12:35:13	950	963	987	985	78	100	21	49	119	580
263:12:36:13	957	970	998	995	77	100	19	67	110	580
263:12:37:13	959	963	997	982	77	100	21	67	112	580
263:12:38:12	945	959	989	987	77	100	19	59	110	580
263:12:39:13	963	974	1000	991	77	100	20	62	111	580
263:12:40:13	961	973	1001	995	77	100	21	60	112	580
263:12:41:12	969	983	1009	1003	77	100	19	61	113	580
263:12:42:13	967	981	1006	1004	77	100	22	61	113	581
263:12:43:13	965	971	1003	999	77	100	21	58	114	580
263:12:44:12	986	989	1025	1009	77	100	20	74	110	581
263:12:45:13	962	964	1001	995	77	100	21	61	113	580
263:12:46:13	965	966	1004	991	77	100	19	57	114	580
263:12:47:13	972	977	1013	999	77	100	22	63	111	580
263:12:48:14	950	958	991	990	77	100	21	58	111	580
263:12:49:13	971	977	1011	993	77	100	19	58	111	580
263:12:50:13	964	980	1016	1013	76	100	16	69	104	580
263:12:51:13	957	961	992	987	76	100	20	59	110	580
263:12:52:13	981	984	1019	1002	77	100	21	73	112	581
263:12:53:13	956	957	995	992	77	100	19	50	115	580
263:12:54:13	971	971	1010	999	77	100	21	54	115	580
263:12:55:13	973	980	1012	1003	76	100	22	66	114	580

C-12

500

TIME DAY:HR:MI:SE	TE117 DEG F	TE118 DEG F	TE119 DEG F	TE120 DEG F	LT151 INCH	FCV151 PERCENT	LT161A INCH	PT181 PSI	PT182 PSI	TE131 DEG F
263:13:52:13	962	973	999	1000	76	100	20	45	121	581
263:13:53:13	972	983	1005	1001	76	100	21	50	121	582
263:13:54:13	968	980	1004	1003	76	100	20	47	121	581
263:13:55:12	969	979	1002	1002	76	100	21	46	122	582
263:13:56:12	964	977	1003	1004	75	100	19	43	120	582
263:13:57:13	969	980	1003	1002	76	100	20	45	122	582
263:13:58:13	971	984	1009	1007	75	100	21	47	121	582
263:13:59:13	973	984	1007	1005	76	100	21	49	122	582
263:14: 0:13	972	984	1007	1004	76	100	20	42	124	582
263:14: 1:13	973	984	1007	1004	76	100	20	38	125	582
263:14: 2:12	970	982	1006	1007	75	100	20	39	124	581
263:14: 3:13	969	979	1003	1005	75	100	20	41	123	581
263:14: 4:12	971	983	1009	1007	75	100	19	43	122	582
263:14: 5:13	981	990	1013	1010	76	100	20	47	125	582
263:14: 6:12	976	985	1013	1010	76	100	22	49	124	582
263:14: 7:13	996	996	1024	1012	76	100	21	60	123	583
263:14: 8:12	966	971	1008	1007	76	100	21	40	123	582
263:14: 9:13	980	974	1006	996	76	100	20	39	128	583
263:14:10:14	968	976	1007	1003	75	100	22	54	119	582
263:14:11:12	983	985	1008	999	76	100	22	54	127	583
263:14:12:13	970	983	1010	1007	75	100	20	45	124	582
263:14:13:12	977	984	1007	1003	76	100	22	52	124	583
263:14:14:13	1001	1003	1029	1014	76	100	25	58	124	584
263:14:15:12	979	985	1020	1016	75	100	24	63	119	583
263:14:16:13	973	981	1006	1002	75	100	22	55	121	583
263:14:17:13	972	983	1007	1004	75	100	20	41	126	583
263:14:18:12	974	985	1009	1007	75	100	20	37	125	583
263:14:19:13	967	977	999	1001	75	100	22	37	126	582
263:14:20:13	967	978	1001	1002	75	100	19	33	127	583
263:14:21:12	975	983	1006	1005	75	100	21	34	126	582
263:14:22:12	977	986	1011	1010	75	100	19	37	127	583
263:14:23:12	968	977	1003	1006	75	100	22	38	126	583
263:14:24:12	981	981	1010	1004	75	100	21	45	128	583
263:14:25:13	986	986	1017	1009	75	100	22	44	128	583
263:14:26:13	962	969	1002	1006	75	100	20	40	124	582
263:14:27:13	991	990	1015	1004	75	100	20	46	126	583
263:14:28:13	967	971	1010	1011	75	100	21	43	122	582
263:14:29:13	973	977	1006	1003	75	100	20	54	121	582
263:14:30:12	967	976	1006	1005	75	100	19	42	124	583
263:14:31:12	982	981	1010	1003	75	100	19	30	129	583
263:14:32:12	972	983	1009	1010	75	100	19	28	129	583
263:14:33:13	975	977	1001	1003	75	100	21	27	132	582
263:14:34:13	977	981	1009	1009	75	100	21	30	131	583
263:14:35:12	976	980	1007	1009	75	100	21	33	128	583
263:14:36:12	978	990	1012	1012	75	100	20	37	127	583
263:14:37:13	980	991	1016	1016	75	100	22	47	123	584
263:14:38:13	971	985	1013	1015	74	100	20	61	121	583
263:14:39:12	970	982	1005	1006	75	100	20	51	125	583
263:14:40:12	975	989	1012	1010	74	100	19	49	123	583
263:14:41:13	976	987	1010	1011	74	100	21	47	124	584
263:14:42:13	971	983	1009	1010	74	100	19	46	123	583
263:14:43:13	976	987	1009	1009	74	100	21	44	125	584
263:14:44:12	984	997	1018	1014	74	100	22	48	129	585
263:14:45:13	979	990	1011	1011	75	100	22	44	128	583
263:14:46:13	976	988	1010	1010	74	100	20	38	128	583
263:14:47:13	978	989	1009	1009	74	100	21	36	127	583

C12

DAY 263 1984 DATA.7:00-17:00

TIME DAY:HR:MI:SE	TE117 DEG F	TE118 DEG F	TE119 DEG F	TE120 DEG F	LT151 INCH	FCV151 PERCENT	LT161A INCH	PT181 PSI	PT182 PSI	TE131 DEG F
263:14:48:13	975	987	1010	1012	74	100	20	35	127	583
263:14:49:12	970	982	1006	1010	74	100	19	33	127	583
263:14:50:12	972	985	1009	1010	74	100	19	34	127	583
263:14:51:12	973	984	1007	1009	74	100	20	35	128	583
263:14:52:12	974	986	1010	1011	74	100	21	38	126	583
263:14:53:12	972	984	1007	1009	74	100	19	35	126	583
263:14:54:12	975	986	1009	1009	74	100	20	37	126	584
263:14:55:14	974	986	1011	1011	74	100	20	42	125	583
263:14:56:13	976	985	1010	1010	74	100	20	42	126	583
263:14:57:13	1000	1002	1021	1011	73	100	24	81	124	585
263:14:58:13	847	861	903	955	71	100	23	53	105	580
263:14:59:13	901	900	910	917	73	100	19	55	122	581
263:15: 0:13	890	898	921	927	72	100	24	54	116	580
263:15: 1:13	892	896	917	920	72	100	18	53	118	581
263:15: 2:12	893	902	922	922	72	100	21	52	116	581
263:15: 3:12	894	898	923	923	72	100	17	50	116	580
263:15: 4:12	882	887	911	918	72	100	20	44	114	580
263:15: 5:12	887	893	912	913	72	100	21	48	116	580
263:15: 6:13	891	899	917	917	72	100	19	50	116	580
263:15: 7:12	890	898	917	918	72	100	21	52	116	579
263:15: 8:12	892	899	917	917	72	100	19	51	117	580
263:15: 9:13	889	897	916	917	72	100	21	47	118	579
263:15:10:14	891	899	918	917	72	100	19	51	116	579
263:15:11:12	888	894	912	915	72	100	20	42	117	579
263:15:12:12	900	907	926	921	72	100	18	42	117	580
263:15:13:12	906	912	930	926	73	100	20	43	121	580
263:15:14:12	915	923	941	935	73	100	18	45	121	580
263:15:15:12	922	929	949	941	73	100	21	48	123	581
263:15:16:12	931	938	956	947	73	100	20	46	124	581
263:15:17:12	937	944	962	953	73	100	21	46	125	581
263:15:18:13	951	957	976	962	72	100	22	67	118	581
263:15:19:12	958	959	985	969	73	100	23	66	121	581
263:15:20:12	945	949	977	970	73	100	19	56	122	581
263:15:21:12	949	954	977	968	72	100	22	60	119	580
263:15:22:13	945	955	976	971	72	100	18	52	119	580
263:15:23:12	967	970	990	978	73	100	21	50	124	581
263:15:24:13	968	969	998	987	72	100	22	62	120	580
263:15:25:13	957	958	986	980	72	100	20	59	120	580
263:15:26:12	954	962	983	979	72	100	20	48	122	580
263:15:27:12	962	971	989	982	72	100	20	47	122	580
263:15:28:12	959	971	992	988	72	100	20	50	121	580
263:15:29:12	964	974	993	988	72	100	20	49	121	579
263:15:30:12	956	967	991	990	72	100	18	49	119	579
263:15:31:13	949	958	982	985	72	100	18	37	123	580
263:15:32:13	959	967	990	986	72	100	20	40	124	580
263:15:33:12	959	966	988	986	72	100	20	42	123	579
263:15:34:12	963	971	992	988	72	100	20	46	123	580
263:15:35:13	962	971	992	989	72	100	20	51	122	580
263:15:36:12	967	976	995	990	72	100	20	48	124	579
263:15:37:12	960	969	990	990	72	100	20	40	125	579
263:15:38:13	955	965	986	986	72	100	17	33	124	579
263:15:39:13	957	964	985	986	72	100	19	31	122	579
263:15:40:13	960	969	990	988	72	100	19	29	123	579
263:15:41:12	959	968	990	989	72	100	18	30	124	579
263:15:42:13	957	966	986	986	72	100	20	32	124	579
263:15:43:13	957	967	987	987	72	100	19	34	124	579

C-15

TIME DAY:HR:MI:SE	TE117 DEC F	TE118 DEC F	TE119 DEC F	TE120 DEC F	LT151 INCH	FCV151 PERCENT	LT161A INCH	PT181 PSI	PT182 PSI	TE131 DEC F
263:15:44:14	957	966	987	987	72	100	20	36	124	580
263:15:45:13	962	971	990	987	72	100	21	40	124	579
263:15:46:13	964	973	992	987	72	100	20	45	125	579
263:15:47:13	965	973	992	987	72	100	21	43	125	579
263:15:48:13	966	975	992	986	72	100	22	44	126	580
263:15:49:13	966	975	992	986	72	100	21	43	126	580
263:15:50:12	965	973	991	986	72	100	21	40	127	580
263:15:51:12	962	971	991	987	72	100	19	45	124	579
263:15:52:13	961	971	990	985	72	100	21	47	124	580
263:15:53:12	966	974	992	985	72	100	21	42	128	580
263:15:54:13	969	977	993	986	72	100	22	41	129	580
263:15:55:12	967	974	991	984	72	100	21	38	129	580
263:15:56:13	969	975	993	985	72	100	21	36	128	580
263:15:57:12	962	969	987	984	72	100	20	32	128	579
263:15:58:13	969	975	990	984	72	100	20	32	129	580
263:15:59:12	965	972	991	986	72	100	21	30	127	580
263:16: 0:12	964	971	991	985	72	100	19	30	127	579
263:16: 1:12	964	972	991	985	72	100	20	33	127	579
263:16: 2:13	967	973	991	984	72	100	21	36	128	579
263:16: 3:13	964	971	988	983	72	100	21	33	128	580
263:16: 4:13	963	970	986	981	72	100	20	30	129	579
263:16: 5:13	966	969	987	982	72	100	20	29	130	579
263:16: 6:13	965	972	991	985	72	100	20	30	129	579
263:16: 7:13	843	876	910	949	73	100	21	17	137	575
263:16: 8:12	683	719	770	852	73	100	21	17	139	569
263:16: 9:13	589	605	641	740	73	100	20	17	140	569
263:16:10:13	574	578	594	669	73	100	20	18	140	569
263:16:11:13	570	571	583	636	72	100	17	45	126	568
263:16:12:13	573	573	583	621	71	100	21	43	124	569
263:16:13:13	572	572	581	611	71	100	8	44	123	569
263:16:14:13	572	572	580	605	71	100	18	44	123	569
263:16:15:13	572	571	580	599	71	100	20	45	123	569
263:16:16:13	572	572	579	596	71	100	20	45	122	569
263:16:17:13	572	571	578	592	72	100	17	17	135	569
263:16:18:12	575	573	580	592	74	100	18	3	151	569
263:16:19:13	578	575	583	590	43	0	3	0	69	568
263:16:20:13	580	577	586	588	4	0	2	0	24	568
263:16:21:12	584	579	588	588	0	0	2	0	13	569
263:16:22:12	585	579	590	587	0	0	2	0	5	569
263:16:23:13	587	580	592	586	0	0	2	0	0	569
263:16:24:13	588	581	594	585	0	0	2	0	0	569
263:16:25:11	589	581	595	584	0	0	2	0	0	569
263:16:26:13	590	581	596	583	0	0	2	0	0	569
263:16:27:12	589	568	595	578	0	0	2	0	0	569
263:16:28:13	586	553	593	568	0	0	2	0	0	567
263:16:29:13	583	546	591	560	0	0	2	0	0	565
263:16:30:13	581	543	589	554	0	0	2	0	0	563
263:16:31:13	580	542	588	550	0	0	2	0	0	561
263:16:32:12	578	541	587	548	0	0	2	0	0	560
263:16:33:13	576	541	586	547	0	0	2	0	0	558
263:16:34:12	575	541	584	546	0	0	2	0	0	557
263:16:35:12	575	541	583	544	0	0	2	0	0	556
263:16:36:12	574	542	583	544	0	0	2	0	0	556
263:16:37:12	572	541	581	543	0	0	2	0	0	555
263:16:38:12	571	541	581	542	0	0	2	0	0	554
263:16:39:11	569	541	579	541	0	80	2	0	0	553

C-16

103



DAY 263 1984 DATA.7:00-17:00

TIME DAY:HR:MI:SE	TE132 DEC F	TE133 DEC F	TE134 DEC F	TE135 DEC F	TE136 DEC F	TE137 DEC F	TE138 DEC F	TE139 DEC F	TE140 DEC F	TE141 DEC F
263:12:0:23	582	581	575	582	579	580	579	579	644	579
263:12:1:23	581	580	574	581	579	579	579	579	644	579
263:12:2:24	582	581	575	582	579	580	579	579	645	579
263:12:3:23	581	580	574	581	578	580	579	578	644	578
263:12:4:24	581	580	574	581	578	578	578	578	645	578
263:12:5:23	579	580	571	578	575	576	575	575	644	575
263:12:6:23	578	578	568	573	572	576	575	572	645	572
263:12:7:23	588	578	583	586	578	585	593	587	644	580
263:12:8:23	625	590	634	711	645	582	636	668	645	654
263:12:9:22	665	619	753	859	804	578	649	723	644	824
263:12:10:23	641	645	733	813	892	582	625	675	644	809
263:12:11:23	655	658	741	841	890	590	642	700	644	819
263:12:12:23	656	671	754	857	922	592	641	700	644	839
263:12:13:23	656	680	742	857	925	584	639	700	644	837
263:12:14:24	662	687	763	877	940	586	644	713	644	855
263:12:15:23	662	692	765	879	952	582	643	712	644	856
263:12:16:23	666	700	791	885	961	580	646	716	644	865
263:12:17:23	667	706	799	885	967	591	647	712	645	866
263:12:18:23	671	712	812	892	971	581	650	720	644	877
263:12:19:23	665	720	818	898	990	572	635	709	644	884
263:12:20:24	663	723	807	895	981	581	641	712	644	873
263:12:21:23	672	724	817	901	976	572	652	727	644	878
263:12:22:23	663	727	804	908	989	564	639	715	644	881
263:12:23:22	662	727	792	897	985	568	639	713	645	867
263:12:24:23	662	725	786	891	973	568	638	710	645	861
263:12:25:22	660	726	789	900	984	570	634	707	645	870
263:12:26:23	661	725	784	893	978	576	637	707	645	864
263:12:27:24	665	724	797	899	979	583	643	714	644	872
263:12:28:23	668	725	806	902	980	583	644	716	644	877
263:12:29:23	669	726	803	903	983	586	649	719	644	878
263:12:30:23	668	727	792	901	983	583	646	717	644	876
263:12:31:23	669	728	806	902	983	583	646	715	644	877
263:12:32:23	667	727	796	903	984	582	645	717	644	877
263:12:33:23	668	727	799	899	984	586	647	714	644	875
263:12:34:23	671	729	807	902	983	587	649	718	645	878
263:12:35:24	669	730	803	904	986	584	647	717	645	880
263:12:36:23	671	731	807	913	995	581	647	720	644	886
263:12:37:23	677	733	830	911	993	581	654	727	644	888
263:12:38:23	670	735	811	903	992	586	647	716	645	880
263:12:39:23	677	737	819	917	995	586	651	725	645	891
263:12:40:23	679	739	823	916	999	589	655	727	645	891
263:12:41:23	680	740	820	924	1005	590	655	727	645	898
263:12:42:23	679	740	821	921	1005	588	652	727	645	894
263:12:43:23	679	741	824	918	1002	585	655	728	645	892
263:12:44:23	679	746	850	937	1017	575	651	737	645	912
263:12:45:23	677	746	838	913	1005	578	654	730	644	891
263:12:46:23	677	747	839	914	1003	578	654	729	645	893
263:12:47:23	675	748	823	923	1009	576	648	725	644	895
263:12:48:23	674	746	824	907	995	581	651	723	644	882
263:12:49:23	676	749	823	924	1003	566	642	724	645	901
263:12:50:23	669	750	824	925	1018	574	639	715	644	898
263:12:51:22	675	748	831	913	997	583	650	725	645	888
263:12:52:24	681	750	837	935	1010	579	656	737	645	905
263:12:53:23	674	748	814	911	1000	572	654	729	645	885
263:12:54:24	675	748	831	921	1007	577	654	728	644	893
263:12:55:23	674	750	812	927	1009	564	650	730	645	894

C-17

601

TIME DAY:HR:MI:SE	TE132 DEC F	TE133 DEC F	TE134 DEC F	TE135 DEC F	TE136 DEC F	TE137 DEC F	TE138 DEC F	TE139 DEC F	TE140 DEC F	TE141 DEC F
263:12:56:23	674	749	826	919	1008	574	647	722	645	890
263:12:57:22	665	745	796	896	986	570	641	712	645	866
263:12:58:23	664	741	802	895	980	572	639	709	645	865
263:12:59:23	662	740	797	900	984	575	634	706	645	869
263:13: 0:23	665	738	798	896	983	579	639	711	645	869
263:13: 1:23	670	737	817	903	982	582	644	717	645	876
263:13: 2:23	672	739	818	906	989	585	647	719	645	880
263:13: 3:23	670	737	796	905	986	583	646	720	645	877
263:13: 4:23	674	737	813	903	985	583	651	719	644	877
263:13: 5:23	671	738	804	905	985	585	649	717	645	878
263:13: 6:23	671	737	803	905	987	585	648	719	645	879
263:13: 7:23	672	738	807	907	986	583	650	720	645	880
263:13: 8:23	671	736	791	904	987	585	649	719	644	876
263:13: 9:23	672	737	806	909	988	586	650	720	645	880
263:13:10:23	672	737	821	905	987	586	650	719	644	879
263:13:11:23	680	744	842	923	997	584	656	733	645	899
263:13:12:23	669	745	817	911	1002	576	644	719	645	885
263:13:13:23	661	744	815	890	989	580	628	698	645	877
263:13:14:24	660	738	800	876	961	576	630	703	645	854
263:13:15:23	666	730	786	868	938	581	645	714	644	840
263:13:16:23	665	732	791	894	958	580	643	714	645	866
263:13:17:23	660	730	782	883	962	580	639	704	645	857
263:13:18:22	665	730	796	884	960	587	646	709	645	859
263:13:19:23	666	732	806	888	959	581	645	711	645	865
263:13:20:23	665	733	807	892	969	586	644	707	645	870
263:13:21:23	668	735	809	901	976	585	644	713	645	877
263:13:22:23	674	738	811	908	980	587	651	725	645	884
263:13:23:23	675	740	816	912	987	588	652	726	645	888
263:13:24:23	673	741	802	913	987	581	650	726	645	885
263:13:25:23	674	741	813	911	988	587	653	726	645	885
263:13:26:23	675	742	815	911	986	587	652	726	644	886
263:13:27:23	672	743	800	912	987	580	650	725	645	884
263:13:28:23	669	742	800	908	988	580	645	720	644	881
263:13:29:22	670	742	812	911	986	586	648	720	644	885
263:13:30:22	676	743	831	911	986	589	653	724	645	888
263:13:31:23	679	745	824	904	985	581	657	732	645	892
263:13:32:23	670	748	821	908	995	578	645	715	646	887
263:13:33:23	671	750	838	914	991	575	643	722	645	892
263:13:34:23	669	750	828	909	991	573	645	721	645	885
263:13:35:23	670	747	821	903	982	581	645	716	645	877
263:13:36:23	679	748	833	918	984	581	654	732	645	892
263:13:37:23	677	749	832	908	989	585	648	722	645	888
263:13:38:23	675	748	810	913	985	588	653	729	645	885
263:13:39:23	674	747	814	912	987	585	650	724	645	885
263:13:40:23	675	747	821	917	991	588	650	726	645	891
263:13:41:23	678	749	830	917	992	587	652	727	645	893
263:13:42:23	680	749	835	922	996	590	654	732	645	898
263:13:43:23	682	751	834	924	996	590	656	732	645	898
263:13:44:23	684	751	841	923	996	594	661	732	645	898
263:13:45:22	681	751	823	926	998	587	655	735	645	899
263:13:46:23	681	751	827	921	999	590	656	732	645	897
263:13:47:23	678	750	817	924	997	586	654	732	645	898
263:13:48:22	678	750	821	921	999	588	654	729	645	897
263:13:49:23	678	751	814	924	999	587	653	731	645	896
263:13:50:23	678	750	810	922	1001	588	653	730	645	895
263:13:51:23	678	750	815	926	1000	587	654	727	645	898

81.0

110

DAY 263 1984 DATA.7:00-17:00

TIME DAY:HR:MI:SE	TE132 DEC F	TE133 DEC F	TE134 DEC F	TE135 DEC F	TE136 DEC F	TE137 DEC F	TE138 DEC F	TE139 DEC F	TE140 DEC F	TE141 DEC F
263:13:52:23	680	750	818	920	999	586	654	730	645	895
263:13:53:23	679	751	815	930	1001	587	656	733	645	902
263:13:54:23	678	751	813	926	1004	583	652	732	645	898
263:13:55:23	679	751	811	926	1002	581	653	733	645	897
263:13:56:23	677	751	815	922	1004	589	652	728	645	897
263:13:57:23	679	751	818	928	1003	587	653	732	645	901
263:13:58:23	680	753	821	930	1008	587	654	733	645	904
263:13:59:24	682	753	819	931	1006	589	656	737	645	903
263:14:0:23	683	753	821	929	1005	590	660	738	645	903
263:14:1:24	679	753	817	929	1005	584	656	733	645	902
263:14:2:24	678	753	813	926	1008	585	651	728	645	900
263:14:3:23	676	753	815	926	1005	582	651	728	645	899
263:14:4:23	678	754	816	929	1009	582	650	730	645	901
263:14:5:23	682	755	818	936	1010	578	654	740	645	903
263:14:6:23	680	755	819	931	1013	575	654	736	645	898
263:14:7:23	688	759	836	950	1016	573	663	755	646	915
263:14:8:22	678	758	825	924	1011	575	655	737	645	895
263:14:9:24	689	759	846	929	1002	579	666	747	645	906
263:14:10:23	679	760	843	924	1007	584	653	729	645	900
263:14:11:23	688	761	834	942	1003	578	660	749	645	903
263:14:12:22	678	759	809	926	1009	579	652	731	645	894
263:14:13:23	686	759	828	935	1004	586	660	742	645	901
263:14:14:23	694	762	838	955	1017	573	669	761	645	917
263:14:15:23	682	762	832	935	1020	576	655	738	645	903
263:14:16:23	683	760	820	931	1005	573	655	742	645	894
263:14:17:23	681	759	814	929	1005	575	654	740	645	893
263:14:18:23	677	758	813	931	1006	578	656	736	645	894
263:14:19:23	678	757	811	923	1001	585	654	731	645	891
263:14:20:23	677	756	808	924	1001	583	651	728	645	892
263:14:21:23	680	757	819	931	1005	580	652	734	644	898
263:14:22:22	682	758	819	932	1010	580	654	736	644	899
263:14:23:23	681	759	820	928	1005	585	657	735	645	898
263:14:24:22	690	761	860	937	1008	586	666	747	645	911
263:14:25:22	691	764	861	940	1012	585	667	748	645	915
263:14:26:23	682	764	843	923	1009	588	656	732	645	901
263:14:27:23	693	767	859	947	1007	582	669	759	644	919
263:14:28:23	683	767	857	924	1015	587	657	734	645	903
263:14:29:24	687	766	855	932	1006	587	657	740	645	906
263:14:30:23	686	766	845	929	1006	587	657	739	645	904
263:14:31:22	694	767	852	940	1007	590	667	751	645	913
263:14:32:23	682	766	833	928	1010	592	654	729	646	905
263:14:33:24	687	764	842	929	1003	595	661	738	644	905
263:14:34:23	689	766	845	934	1008	595	663	738	646	910
263:14:35:23	687	766	846	934	1009	587	659	736	645	909
263:14:36:23	683	766	824	937	1011	582	656	739	645	906
263:14:37:23	682	766	825	938	1015	573	651	739	646	904
263:14:38:23	679	766	824	930	1013	578	646	732	646	900
263:14:39:22	687	762	818	932	1005	582	661	747	645	897
263:14:40:22	685	764	825	936	1009	583	657	742	646	903
263:14:41:23	686	763	824	936	1010	582	658	743	646	903
263:14:42:23	684	763	836	931	1010	587	656	740	645	904
263:14:43:23	688	765	833	937	1007	590	661	746	646	908
263:14:44:23	690	765	832	943	1013	589	665	750	645	911
263:14:45:22	690	763	828	936	1010	591	665	747	645	906
263:14:46:23	690	763	832	934	1009	594	666	742	646	907
263:14:47:22	687	762	827	937	1007	590	662	741	645	909

C-11

111

TIME DAY:HR:MI:SE	TE132 DEG F	TE133 DEG F	TE134 DEG F	TE135 DEG F	TE136 DEG F	TE137 DEG F	TE138 DEG F	TE139 DEG F	TE140 DEG F	TE141 DEG F
263:14:48:22	684	762	825	933	1010	590	659	738	645	907
263:14:49:23	683	762	822	930	1008	586	656	737	645	904
263:14:50:23	687	763	827	933	1009	589	657	738	645	907
263:14:51:22	690	763	837	935	1007	590	661	743	645	909
263:14:52:23	688	765	838	934	1010	590	661	741	645	911
263:14:53:22	687	765	839	934	1009	589	659	740	645	908
263:14:54:23	690	766	841	936	1009	593	662	742	646	911
263:14:55:22	688	766	837	938	1011	591	662	744	645	913
263:14:56:23	692	766	842	937	1010	594	666	748	645	912
263:14:57:23	700	768	843	954	1014	588	674	765	645	920
263:14:58:23	651	754	763	831	947	581	633	686	645	836
263:14:59:23	671	747	793	877	910	589	651	721	645	839
263:15: 0:23	667	742	798	862	924	588	644	705	645	839
263:15: 1:23	668	740	797	862	918	585	647	711	645	838
263:15: 2:22	661	737	779	865	921	575	639	704	645	839
263:15: 3:23	662	736	793	865	924	577	638	705	645	841
263:15: 4:23	660	734	779	856	917	580	639	700	646	834
263:15: 5:23	660	732	774	859	914	580	641	704	645	833
263:15: 6:23	661	730	770	862	917	580	640	703	645	837
263:15: 7:23	658	729	771	862	919	580	639	703	645	836
263:15: 8:23	659	728	772	862	917	581	641	704	645	836
263:15: 9:24	660	728	765	860	918	581	639	704	645	835
263:15:10:23	660	728	768	863	919	580	639	702	645	837
263:15:11:23	659	727	765	859	916	579	639	704	645	833
263:15:12:23	662	729	781	870	923	582	640	706	646	843
263:15:13:23	668	730	791	876	929	588	647	714	645	848
263:15:14:23	672	735	802	885	938	586	648	719	646	860
263:15:15:22	675	737	809	891	945	587	653	726	646	866
263:15:16:22	678	740	813	897	951	590	656	729	646	873
263:15:17:23	678	742	819	902	958	585	657	730	646	878
263:15:18:23	682	748	833	913	968	588	654	733	646	891
263:15:19:22	682	752	839	918	977	576	653	740	645	894
263:15:20:22	681	753	829	907	977	580	659	733	646	884
263:15:21:22	681	753	830	913	973	580	656	734	646	888
263:15:22:22	680	753	819	911	975	587	654	733	646	885
263:15:23:22	687	754	833	927	983	585	663	746	646	898
263:15:24:22	687	757	851	926	993	578	660	744	645	902
263:15:25:22	687	759	846	919	985	580	661	741	646	896
263:15:26:22	688	759	834	917	983	587	657	735	646	894
263:15:27:22	687	759	830	926	985	589	660	740	646	901
263:15:28:22	684	758	829	926	992	589	657	737	646	901
263:15:29:22	680	757	817	927	992	579	650	735	646	897
263:15:30:22	678	757	819	922	993	579	648	730	646	892
263:15:31:22	681	757	827	916	987	587	652	728	645	892
263:15:32:22	682	757	829	924	989	587	653	732	646	898
263:15:33:23	686	759	833	925	989	588	657	736	646	899
263:15:34:23	687	760	845	928	991	589	660	738	646	904
263:15:35:22	686	760	834	927	992	587	657	739	646	903
263:15:36:23	684	759	820	930	992	579	657	740	645	901
263:15:37:22	679	758	817	922	992	576	653	735	645	893
263:15:38:23	679	759	826	920	989	588	652	727	645	897
263:15:39:22	684	759	837	922	988	589	658	732	645	898
263:15:40:22	687	760	824	925	991	591	651	729	645	895
263:15:41:24	679	759	806	922	993	586	649	728	646	897
263:15:42:23	680	757	807	921	991	585	649	728	645	894
263:15:43:22	680	756	812	921	990	585	650	727	646	895

C20

112

DAY 263 1984 DATA.7:00-17:00

TIME DAY:HR:MI:SE	TE132 DEC F	TE133 DEC F	TE134 DEC F	TE135 DEC F	TE136 DEC F	TE137 DEC F	TE138 DEC F	TE139 DEC F	TE140 DEC F	TE141 DEC F
263:15:44:22	680	757	819	923	990	582	651	729	646	897
263:15:45:22	684	757	788	926	992	589	647	734	646	890
263:15:46:23	682	757	804	927	993	585	652	736	646	897
263:15:47:22	685	756	813	928	992	586	651	737	646	898
263:15:48:23	686	756	813	927	992	586	659	740	646	898
263:15:49:24	685	756	806	927	991	586	658	739	646	898
263:15:50:22	682	756	811	927	991	581	656	737	646	898
263:15:51:23	679	756	819	925	992	582	649	731	646	897
263:15:52:22	682	756	813	925	991	585	654	737	646	897
263:15:53:22	685	757	811	929	991	586	657	741	646	899
263:15:54:22	687	756	814	930	991	587	659	741	646	901
263:15:55:23	688	756	815	930	991	590	662	743	646	897
263:15:56:22	686	757	817	931	991	588	658	740	646	899
263:15:57:23	687	757	825	925	990	591	663	738	646	896
263:15:58:22	689	758	828	931	990	592	662	740	646	899
263:15:59:23	686	758	801	929	993	591	654	736	646	895
263:16: 0:22	683	757	786	927	993	590	651	734	646	890
263:16: 1:22	683	757	779	927	993	589	653	738	645	891
263:16: 2:22	684	756	779	929	992	588	654	739	646	892
263:16: 3:23	684	755	807	925	991	588	654	738	645	895
263:16: 4:23	685	756	813	925	988	587	660	738	646	897
263:16: 5:23	686	757	832	929	989	588	661	738	646	902
263:16: 6:23	684	757	817	929	992	586	656	738	646	900
263:16: 7:22	616	737	717	813	950	521	580	605	646	828
263:16: 8:23	589	702	620	694	853	515	571	543	646	730
263:16: 9:23	580	666	583	612	727	548	569	557	646	641
263:16:10:22	578	639	580	593	645	580	571	565	647	601
263:16:11:22	575	624	576	587	609	543	571	555	646	585
263:16:12:22	576	616	575	587	597	539	572	551	647	581
263:16:13:22	575	609	571	585	591	538	571	548	646	578
263:16:14:23	575	605	572	584	589	562	571	566	647	578
263:16:15:23	573	602	571	582	587	564	572	565	646	576
263:16:16:22	573	598	569	581	586	547	571	551	646	575
263:16:17:23	573	596	568	581	584	541	571	550	646	575
263:16:18:23	574	595	567	583	585	534	569	542	647	575
263:16:19:23	574	594	562	584	587	527	569	540	646	575
263:16:20:23	574	593	564	586	589	557	568	563	646	575
263:16:21:23	575	591	563	588	591	559	568	563	647	575
263:16:22:22	574	591	562	589	594	560	566	562	646	575
263:16:23:23	574	590	562	590	595	561	566	561	646	575
263:16:24:22	575	590	561	591	596	561	565	558	646	575
263:16:25:23	575	590	560	592	598	555	564	549	646	575
263:16:26:23	575	591	548	593	599	534	562	525	646	574
263:16:27:23	571	589	549	588	599	537	545	529	647	568
263:16:28:23	564	586	546	580	598	524	529	522	647	556
263:16:29:23	557	581	542	576	596	518	523	517	646	547
263:16:30:24	554	577	539	574	595	516	521	515	646	541
263:16:31:22	551	573	536	571	592	515	518	514	646	537
263:16:32:23	549	569	535	569	591	516	518	514	646	535
263:16:33:23	548	568	533	568	590	516	517	514	646	533
263:16:34:23	548	566	531	566	588	516	517	513	646	532
263:16:35:22	547	564	531	565	588	517	517	513	646	532
263:16:36:22	546	563	530	564	587	518	518	514	646	531
263:16:37:23	545	561	529	563	586	518	517	513	646	529
263:16:38:22	544	560	529	563	585	518	518	505	646	530
263:16:39:22	543	559	525	561	583	516	516	504	646	529

TIME DAY:HR:MI:SE	TE142 DEG F	TE143 DEG F	TE144 DEG F	TE145 DEG F	TE146 DEG F	TE147 DEG F	TE148 DEG F	RMAXT DEG F	RMINT DEG F	TE182 DEG F
263:12:0:23	579	580	579	581	582	579	579	644	575	582
263:12:1:23	579	580	579	581	582	578	578	644	575	582
263:12:2:24	579	580	579	581	582	578	578	644	575	583
263:12:3:23	578	579	580	581	581	578	578	644	574	582
263:12:4:24	578	580	573	581	581	578	577	645	573	583
263:12:5:23	575	579	571	576	577	575	574	644	571	583
263:12:6:23	570	579	572	575	574	571	570	645	568	582
263:12:7:23	584	579	593	596	596	576	582	644	573	582
263:12:8:23	666	580	630	684	720	668	657	694	578	582
263:12:9:22	846	580	637	728	799	792	819	859	578	582
263:12:10:23	852	580	624	683	741	817	898	898	580	582
263:12:11:23	873	580	638	713	776	834	895	895	580	582
263:12:12:23	898	580	633	711	774	847	934	931	580	582
263:12:13:23	902	580	636	713	777	852	937	937	580	582
263:12:14:24	921	580	641	724	793	870	950	944	580	582
263:12:15:23	927	579	639	724	795	879	964	961	579	582
263:12:16:23	918	578	638	723	795	885	956	961	578	583
263:12:17:23	929	578	640	724	796	889	950	967	578	583
263:12:18:23	930	576	637	724	799	893	952	970	576	582
263:12:19:23	924	575	627	711	788	898	964	991	571	582
263:12:20:24	934	575	635	721	798	897	961	983	573	582
263:12:21:23	924	573	638	730	806	901	955	975	573	582
263:12:22:23	948	573	629	718	797	902	975	989	564	582
263:12:23:22	946	573	630	719	793	892	973	985	568	582
263:12:24:23	937	573	629	719	793	892	967	973	571	582
263:12:25:22	951	573	627	718	796	903	981	983	569	582
263:12:26:23	941	573	632	720	796	898	977	982	573	582
263:12:27:24	945	573	637	725	801	899	985	984	573	582
263:12:28:23	943	573	637	727	805	893	987	987	573	582
263:12:29:23	947	572	640	729	807	892	991	991	572	582
263:12:30:23	950	573	640	728	805	889	995	995	573	582
263:12:31:23	949	572	638	727	803	885	984	985	572	582
263:12:32:23	953	572	639	729	806	890	994	994	572	582
263:12:33:23	944	573	635	725	799	889	994	994	573	582
263:12:34:23	946	573	638	728	803	887	993	993	573	582
263:12:35:24	953	573	640	729	804	891	997	997	573	582
263:12:36:23	962	573	638	732	810	901	998	998	573	582
263:12:37:23	947	572	639	733	812	909	965	993	572	582
263:12:38:23	949	573	639	727	803	903	985	992	573	582
263:12:39:23	966	574	642	737	816	908	984	992	574	582
263:12:40:23	963	573	641	737	815	905	994	999	573	582
263:12:41:23	969	573	636	736	816	906	1014	1011	573	582
263:12:42:23	966	573	643	738	818	905	1014	1015	573	582
263:12:43:23	965	573	645	740	817	907	992	1002	573	583
263:12:44:23	960	572	639	738	824	924	995	1017	572	583
263:12:45:23	941	571	641	735	813	912	976	1008	571	582
263:12:46:23	943	571	641	733	813	913	971	1003	571	583
263:12:47:23	959	571	638	733	815	918	984	1007	569	582
263:12:48:23	941	571	641	732	809	912	971	997	571	582
263:12:49:23	963	571	631	726	810	922	985	1003	572	582
263:12:50:23	975	571	629	723	809	925	1008	1018	571	583
263:12:51:22	947	572	639	734	814	916	967	997	572	582
263:12:52:24	964	571	641	742	828	927	989	1010	571	583
263:12:53:23	944	572	639	733	812	916	977	1002	572	582
263:12:54:24	959	571	642	734	815	924	985	1005	571	582
263:12:55:23	972	571	633	732	812	917	996	1007	566	582

C22

119

DAY 263 1984 DATA.7:00-17:00

TIME DAY:HR:MI:SE	TE142 DEC F	TE143 DEC F	TE144 DEC F	TE145 DEC F	TE146 DEC F	TE147 DEC F	TE148 DEC F	RMAXT DEC F	RMINT DEC F	TE182 DEC F
263:12:56:23	954	571	632	726	806	911	987	1008	571	583
263:12:57:22	943	571	633	724	798	903	977	986	570	583
263:12:58:23	940	571	631	720	796	901	974	981	571	583
263:12:59:23	949	571	629	718	797	904	988	988	571	582
263:13:0:23	944	572	635	723	798	900	990	990	572	582
263:13:1:23	944	572	634	728	804	898	991	991	572	582
263:13:2:23	947	572	636	730	806	896	997	999	572	582
263:13:3:23	955	572	640	732	806	897	998	997	572	582
263:13:4:23	945	572	641	731	806	890	996	996	572	582
263:13:5:23	952	572	639	729	805	889	996	996	572	582
263:13:6:23	951	572	638	730	805	888	997	997	572	582
263:13:7:23	950	572	641	732	806	890	997	996	572	582
263:13:8:23	955	572	641	732	804	887	1000	998	571	582
263:13:9:23	954	572	638	733	808	893	997	998	572	582
263:13:10:23	950	572	639	732	806	890	984	987	572	582
263:13:11:23	956	571	643	741	823	917	981	997	571	582
263:13:12:23	959	571	635	727	803	915	995	1002	571	582
263:13:13:23	930	571	621	705	781	903	974	995	571	582
263:13:14:24	905	571	624	709	781	883	953	964	571	582
263:13:15:23	902	572	641	727	791	868	939	939	572	581
263:13:16:23	939	572	640	727	800	888	966	959	572	582
263:13:17:23	930	572	637	719	790	888	972	972	572	582
263:13:18:22	923	573	639	721	791	878	968	968	573	582
263:13:19:23	921	573	635	722	793	877	966	966	573	582
263:13:20:23	936	572	632	717	793	880	977	976	572	582
263:13:21:23	943	572	638	726	802	890	983	985	572	582
263:13:22:23	948	572	644	738	812	895	987	987	572	582
263:13:23:23	950	572	641	736	812	900	995	994	572	582
263:13:24:23	959	572	645	740	814	905	997	997	572	582
263:13:25:23	957	572	646	739	814	902	996	996	572	582
263:13:26:23	950	572	646	740	814	900	992	992	572	582
263:13:27:23	959	572	644	740	817	908	995	995	571	582
263:13:28:23	955	571	641	733	807	905	997	997	572	582
263:13:29:22	954	572	639	731	807	898	995	996	571	582
263:13:30:22	944	572	641	735	811	897	994	993	571	582
263:13:31:23	941	571	641	735	813	901	973	985	571	582
263:13:32:23	947	571	636	721	798	912	985	995	571	582
263:13:33:23	927	569	634	726	806	913	982	991	569	582
263:13:34:23	930	570	633	725	802	907	983	992	570	583
263:13:35:23	937	570	637	726	802	905	980	984	569	583
263:13:36:23	940	570	641	740	820	917	977	981	571	582
263:13:37:23	941	571	641	733	812	913	983	989	571	582
263:13:38:23	957	572	647	742	818	916	990	990	572	582
263:13:39:23	955	571	645	737	812	912	995	995	571	582
263:13:40:23	955	571	643	738	816	911	997	997	571	582
263:13:41:23	952	572	641	740	816	910	993	993	572	582
263:13:42:23	957	571	640	742	823	915	1000	997	571	582
263:13:43:23	959	571	642	741	819	911	1004	1003	572	582
263:13:44:23	956	571	645	742	820	910	1003	1003	571	582
263:13:45:22	969	571	646	745	822	909	1007	1007	571	582
263:13:46:23	960	571	644	744	820	906	1007	1007	571	582
263:13:47:23	968	571	647	746	822	910	1005	1004	571	583
263:13:48:22	964	571	647	742	819	911	1007	1006	571	582
263:13:49:23	970	572	648	745	819	908	1007	1007	572	582
263:13:50:23	970	572	644	741	817	906	1010	1010	572	582
263:13:51:23	971	571	644	740	817	909	1010	1010	571	582

C-23

120

TIME DAY:HR:MI:SE	TE142 DEC F	TE143 DEC F	TE144 DEC F	TE145 DEC F	TE146 DEC F	TE147 DEC F	TE148 DEC F	RMAXT DEC F	RMINT DEC F	TE182 DEC F
263:13:52:23	966	571	648	744	819	905	1009	1009	571	582
263:13:53:23	976	571	647	745	822	906	1011	1011	571	582
263:13:54:23	973	571	648	746	820	904	1013	1013	571	582
263:13:55:23	973	571	645	748	823	916	1010	1010	572	582
263:13:56:23	971	571	645	740	817	909	1014	1014	572	582
263:13:57:23	975	571	647	744	823	909	1013	1011	571	582
263:13:58:23	977	571	647	746	824	907	1018	1018	571	582
263:13:59:24	977	571	650	748	825	906	1016	1016	571	583
263:14: 0:23	975	571	652	751	827	909	1014	1014	571	582
263:14: 1:24	977	571	649	749	825	917	1013	1013	571	582
263:14: 2:24	976	571	647	744	820	909	1017	1017	571	582
263:14: 3:23	974	571	645	744	821	917	1014	1014	571	582
263:14: 4:23	977	571	643	746	826	925	1017	1017	571	582
263:14: 5:23	982	571	645	752	835	938	1015	1013	571	582
263:14: 6:23	980	571	644	747	826	935	1015	1015	571	581
263:14: 7:23	990	570	647	758	839	933	1014	1014	570	582
263:14: 8:22	953	569	643	741	816	920	1004	1013	569	581
263:14: 9:24	954	569	649	749	829	926	989	1001	569	581
263:14:10:23	961	570	643	739	817	926	997	1007	569	581
263:14:11:23	979	570	649	758	841	936	1000	1000	570	581
263:14:12:22	973	571	647	747	823	932	1014	1014	571	582
263:14:13:23	976	572	653	756	836	935	1006	1006	572	582
263:14:14:23	997	571	654	765	847	939	1016	1017	571	582
263:14:15:23	975	571	642	744	821	932	1015	1020	571	581
263:14:16:23	975	570	645	750	829	927	1002	1004	570	582
263:14:17:23	974	571	646	750	828	928	1006	1004	571	581
263:14:18:23	976	571	643	750	827	931	1010	1010	571	582
263:14:19:23	969	572	649	747	823	927	1007	1007	572	581
263:14:20:23	971	572	646	745	825	929	1009	1009	572	582
263:14:21:23	977	571	645	749	832	934	1010	1010	571	581
263:14:22:22	980	571	640	753	834	936	1014	1014	571	581
263:14:23:23	968	572	650	750	829	931	1006	1007	572	582
263:14:24:22	959	571	653	756	839	938	1002	1006	571	582
263:14:25:22	963	570	653	756	839	944	1004	1012	570	581
263:14:26:23	962	570	647	743	822	933	1001	1009	570	581
263:14:27:23	961	570	654	763	846	944	1000	1007	570	581
263:14:28:23	964	570	642	740	819	937	1006	1015	570	581
263:14:29:24	967	570	646	748	831	936	998	1005	570	581
263:14:30:23	966	571	648	751	831	935	1002	1006	570	582
263:14:31:22	969	571	657	764	845	943	1000	1005	571	581
263:14:32:23	971	571	649	753	825	931	1013	1014	571	581
263:14:33:24	962	571	654	753	835	925	1002	1003	571	581
263:14:34:23	972	573	655	753	836	927	1008	1008	573	582
263:14:35:23	967	572	652	751	833	931	1008	1010	572	581
263:14:36:23	982	572	648	754	838	938	1017	1017	572	582
263:14:37:23	981	572	642	749	832	939	1020	1021	572	582
263:14:38:23	976	572	638	743	827	936	1017	1018	572	582
263:14:39:22	976	571	651	761	839	934	1012	1012	571	582
263:14:40:22	983	572	650	756	834	938	1016	1016	572	582
263:14:41:23	982	572	648	758	839	938	1016	1016	572	582
263:14:42:23	974	572	649	751	832	932	1014	1013	572	582
263:14:43:23	979	573	654	759	839	929	1015	1014	573	582
263:14:44:23	987	572	656	761	840	931	1022	1020	573	581
263:14:45:22	983	572	656	758	838	921	1019	1019	572	581
263:14:46:23	977	572	658	756	833	919	1017	1017	572	582
263:14:47:22	982	572	655	754	834	920	1016	1016	572	581

C-24



DAY 263 1984 DATA.7:00-17:00

TIME DAY:HR:MI:SE	TE142 DEC F	TE143 DEC F	TE144 DEC F	TE145 DEC F	TE146 DEC F	TE147 DEC F	TE148 DEC F	RMAXT DEC F	RMINT DEC F	TE182 DEC F
263:14:48:22	982	572	653	751	829	917	1020	1020	572	581
263:14:49:23	977	572	650	753	830	917	1016	1016	572	581
263:14:50:23	979	572	652	752	831	918	1018	1018	572	582
263:14:51:22	974	572	653	757	834	919	1016	1016	572	581
263:14:52:23	979	571	648	753	831	921	1018	1018	571	581
263:14:53:22	976	571	650	753	831	919	1016	1016	571	582
263:14:54:23	976	572	651	753	832	918	1016	1016	572	581
263:14:55:22	979	571	651	754	835	920	1020	1020	571	581
263:14:56:23	978	571	654	760	838	919	1015	1017	571	581
263:14:57:23	991	571	662	774	856	941	1016	1010	571	581
263:14:58:23	865	571	632	699	753	865	939	965	571	581
263:14:59:23	885	571	638	733	797	855	918	912	571	581
263:15:0:23	890	571	632	714	773	848	931	931	571	581
263:15:1:23	889	571	636	720	781	839	923	923	571	581
263:15:2:22	898	570	632	714	778	842	927	927	570	581
263:15:3:23	885	569	631	713	779	856	930	930	570	581
263:15:4:23	879	570	636	712	775	858	922	923	569	582
263:15:5:23	891	569	639	716	779	852	920	919	569	581
263:15:6:23	897	570	637	715	779	848	924	923	570	581
263:15:7:23	896	570	635	715	779	843	925	925	570	582
263:15:8:23	897	569	637	716	779	840	923	923	569	581
263:15:9:24	893	569	636	716	774	834	924	924	569	581
263:15:10:23	896	569	634	713	775	829	926	925	569	582
263:15:11:23	893	569	637	717	779	827	922	922	569	581
263:15:12:23	905	569	634	719	784	843	931	931	570	581
263:15:13:23	907	569	632	725	788	846	936	936	569	581
263:15:14:23	913	569	635	727	795	858	946	946	569	582
263:15:15:22	921	569	642	737	806	861	953	953	569	582
263:15:16:22	929	569	641	740	806	867	959	959	569	581
263:15:17:23	932	569	644	740	809	876	965	965	569	581
263:15:18:23	946	569	640	740	817	894	973	971	569	582
263:15:19:22	938	568	639	743	823	907	977	975	568	582
263:15:20:22	931	569	647	741	814	908	977	977	569	582
263:15:21:22	933	568	645	744	820	915	976	976	568	581
263:15:22:22	948	569	646	745	821	909	981	981	569	581
263:15:23:22	956	569	651	756	834	924	989	986	569	581
263:15:24:22	946	569	645	748	825	928	993	993	569	581
263:15:25:22	933	568	646	745	823	923	984	986	569	582
263:15:26:22	949	569	647	746	823	911	986	986	569	581
263:15:27:22	959	569	650	751	831	913	993	993	569	581
263:15:28:22	962	569	647	747	827	913	999	999	569	581
263:15:29:22	968	569	642	747	825	922	1000	1000	569	581
263:15:30:22	964	569	639	742	823	924	1000	1000	569	581
263:15:31:22	950	569	645	741	821	912	993	996	569	581
263:15:32:22	963	569	648	745	826	915	996	995	569	581
263:15:33:23	962	569	646	746	827	911	995	995	569	581
263:15:34:23	959	569	647	748	829	911	998	998	569	581
263:15:35:22	963	569	648	751	829	909	999	999	569	581
263:15:36:23	969	569	648	754	832	920	1000	1000	569	581
263:15:37:22	964	569	645	746	823	919	999	1000	569	581
263:15:38:23	961	569	645	739	819	911	996	997	569	582
263:15:39:22	954	569	647	744	824	906	995	996	569	581
263:15:40:22	962	569	636	742	820	886	999	998	569	581
263:15:41:24	963	568	633	740	817	897	999	1000	568	582
263:15:42:23	960	567	645	740	818	891	997	997	567	581
263:15:43:22	962	567	645	740	817	889	997	997	567	581

C-25

TIME DAY:HR:MI:SE	TE142 DEG F	TE143 DEG F	TE144 DEG F	TE145 DEG F	TE146 DEG F	TE147 DEG F	TE148 DEG F	RMAXT DEG F	RMINT DEG F	TE182 DEG F
263:15:44:22	962	568	645	744	820	891	997	997	568	582
263:15:45:22	964	568	634	747	819	889	998	999	568	582
263:15:46:23	966	566	641	748	823	885	999	999	566	581
263:15:47:22	968	566	644	748	823	887	999	999	566	581
263:15:48:23	969	566	653	753	826	889	998	998	566	582
263:15:49:24	969	567	651	750	823	894	997	997	567	581
263:15:50:22	968	568	646	751	828	901	997	997	568	581
263:15:51:23	966	567	645	743	819	900	999	999	567	581
263:15:52:22	966	568	647	747	824	895	997	997	568	582
263:15:53:22	968	569	651	752	826	893	997	997	569	581
263:15:54:22	970	569	656	753	826	896	999	999	569	581
263:15:55:23	966	568	645	753	828	886	997	997	568	581
263:15:56:22	969	566	650	751	827	889	997	997	566	581
263:15:57:23	961	566	645	749	823	890	995	995	566	581
263:15:58:22	967	568	646	753	827	901	996	996	566	581
263:15:59:23	967	567	639	750	823	895	999	999	568	581
263:16:0:22	966	566	636	748	819	889	999	999	566	581
263:16:1:22	966	565	635	749	821	881	998	998	565	581
263:16:2:22	965	564	641	753	825	884	997	997	564	581
263:16:3:23	965	564	653	749	823	887	996	996	564	581
263:16:4:23	965	564	654	752	827	891	993	993	564	581
263:16:5:23	959	565	653	753	830	905	995	994	565	581
263:16:6:23	968	566	654	751	825	903	998	998	566	581
263:16:7:22	858	564	575	633	689	848	943	965	518	581
263:16:8:23	731	564	568	583	598	753	834	853	515	581
263:16:9:23	616	564	569	574	573	651	700	727	548	580
263:16:10:22	584	565	571	574	571	604	624	654	562	581
263:16:11:22	577	564	569	575	571	583	597	646	549	581
263:16:12:22	578	565	571	575	572	579	590	646	539	582
263:16:13:22	577	565	569	575	571	575	587	647	540	581
263:16:14:23	577	566	572	575	572	573	586	647	550	582
263:16:15:23	576	565	571	575	572	572	583	646	564	581
263:16:16:22	575	565	570	575	571	571	582	646	547	581
263:16:17:23	575	565	569	574	571	569	581	646	543	581
263:16:18:23	578	565	566	575	567	568	581	647	535	581
263:16:19:23	581	562	563	574	563	564	581	646	523	582
263:16:20:23	582	560	565	574	562	563	582	646	556	591
263:16:21:23	585	558	564	573	559	563	583	647	558	575
263:16:22:22	585	556	563	572	555	562	583	646	555	569
263:16:23:23	586	554	562	571	552	560	583	646	552	566
263:16:24:22	586	553	561	571	547	558	582	646	547	570
263:16:25:23	587	550	558	569	541	556	582	646	542	575
263:16:26:23	587	548	554	568	535	554	582	646	535	576
263:16:27:23	575	540	538	548	515	545	575	646	518	579
263:16:28:23	562	528	521	532	499	530	563	646	500	580
263:16:29:23	557	519	514	526	493	522	556	646	493	581
263:16:30:24	554	511	510	523	489	514	552	646	489	581
263:16:31:22	551	506	508	521	487	510	549	646	487	581
263:16:32:23	550	503	508	519	486	508	548	646	486	582
263:16:33:23	550	501	507	518	486	507	547	646	487	582
263:16:34:23	549	499	506	517	487	507	546	646	487	582
263:16:35:22	549	499	506	517	487	506	545	646	487	582
263:16:36:22	550	498	507	517	488	507	545	646	488	582
263:16:37:23	548	496	507	516	488	506	543	646	488	582
263:16:38:22	548	496	505	516	488	507	543	646	488	583
263:16:39:22	548	495	503	516	485	505	543	646	485	582

C26

DAY 263 1984 DATA.7:00-17:00

TIME DAY:HR:MI:SE	TE183 DEC F	TE184 DEC F	TE185 DEC F	TE186 DEC F	TE187 DEC F	TE188 DEC F	TE189 DEC F	TE190 DEC F	TE191 DEC F	TE192 DEC F
263:12:0:23	580	316	586	583	584	166	587	582	589	583
263:12:1:23	580	317	585	583	584	166	586	582	589	583
263:12:2:24	579	316	585	583	584	166	586	582	589	582
263:12:3:23	579	316	585	582	583	166	586	582	588	582
263:12:4:24	579	317	585	583	584	167	586	582	589	582
263:12:5:23	579	317	584	581	582	166	583	579	587	579
263:12:6:23	575	316	583	580	581	166	581	576	584	576
263:12:7:23	573	318	587	588	586	167	588	587	590	587
263:12:8:23	582	318	597	608	609	173	625	648	644	674
263:12:9:22	660	326	603	621	634	179	674	712	716	764
263:12:10:23	915	324	598	608	625	176	662	679	704	723
263:12:11:23	906	314	600	614	627	177	667	692	709	741
263:12:12:23	939	347	602	615	632	178	674	698	720	750
263:12:13:23	944	357	600	615	630	177	674	699	720	751
263:12:14:24	950	341	602	618	633	179	680	708	728	764
263:12:15:23	968	336	601	617	635	180	682	708	729	765
263:12:16:23	974	329	600	617	634	180	683	710	733	768
263:12:17:23	985	339	599	616	633	179	682	708	733	766
263:12:18:23	985	332	599	617	635	180	686	714	738	774
263:12:19:23	1003	330	598	614	636	179	687	713	743	775
263:12:20:24	1003	344	598	615	635	180	685	712	739	772
263:12:21:23	991	338	598	618	635	180	686	717	740	777
263:12:22:23	997	335	598	615	635	179	686	715	743	779
263:12:23:22	1004	338	597	614	633	179	683	710	737	771
263:12:24:23	992	332	597	614	632	179	681	708	735	768
263:12:25:22	995	336	597	614	634	180	684	711	740	773
263:12:26:23	997	332	596	613	632	179	682	707	736	768
263:12:27:24	991	332	596	614	633	179	684	712	738	773
263:12:28:23	993	329	596	615	633	180	685	713	740	775
263:12:29:23	994	329	595	615	633	180	686	713	739	775
263:12:30:23	997	330	595	614	632	179	684	713	738	774
263:12:31:23	997	329	594	614	631	179	684	712	738	774
263:12:32:23	996	328	594	615	632	180	685	714	738	775
263:12:33:23	997	325	594	614	632	180	683	711	737	772
263:12:34:23	996	328	595	615	632	180	686	714	738	775
263:12:35:24	997	327	595	616	633	181	687	715	740	776
263:12:36:23	1004	323	594	615	633	181	688	717	742	781
263:12:37:23	1005	328	595	616	634	181	688	720	742	783
263:12:38:23	1009	336	595	615	634	181	686	714	740	775
263:12:39:23	1002	333	595	616	636	182	690	721	745	784
263:12:40:23	1011	342	595	616	636	182	691	721	746	784
263:12:41:23	1014	334	594	617	636	182	693	723	748	788
263:12:42:23	1018	333	594	617	636	182	692	723	747	787
263:12:43:23	1016	335	594	618	636	183	692	722	746	785
263:12:44:23	1019	337	596	620	641	183	700	733	758	801
263:12:45:23	1024	344	595	617	636	182	691	722	747	785
263:12:46:23	1015	336	596	617	637	182	692	723	748	786
263:12:47:23	1017	339	596	616	637	182	693	723	751	788
263:12:48:23	1013	345	595	615	635	182	688	717	744	779
263:12:49:23	1010	341	597	616	638	182	694	727	754	791
263:12:50:23	1031	343	597	617	640	183	696	725	757	792
263:12:51:22	1014	349	596	616	636	182	691	721	748	785
263:12:52:24	1014	349	597	619	641	183	698	732	758	799
263:12:53:23	1019	343	596	619	636	182	690	720	747	782
263:12:54:24	1017	346	597	617	638	183	693	723	752	788
263:12:55:23	1019	339	596	617	638	183	694	726	754	792

C27

TIME DAY:HR:MI:SE	TE183 DEC F	TE184 DEC F	TE185 DEC F	TE186 DEC F	TE187 DEC F	TE188 DEC F	TE189 DEC F	TE190 DEC F	TE191 DEC F	TE192 DEC F
263:12:56:23	1021	347	596	615	637	182	692	720	751	785
263:12:57:22	1007	340	596	614	633	181	684	711	740	770
263:12:58:23	992	353	596	613	633	182	684	709	738	770
263:12:59:23	993	341	596	613	633	181	686	711	740	772
263:13:0:23	994	342	596	613	633	182	685	711	737	770
263:13:1:23	991	339	595	614	633	182	686	714	739	775
263:13:2:23	995	342	595	615	633	182	687	715	740	777
263:13:3:23	997	343	595	615	633	182	687	714	739	776
263:13:4:23	997	344	594	615	632	182	685	713	736	774
263:13:5:23	997	343	593	615	632	182	686	713	737	774
263:13:6:23	997	342	593	615	632	182	686	714	737	775
263:13:7:23	997	342	594	616	632	182	686	715	737	775
263:13:8:23	997	336	594	616	632	182	686	714	736	774
263:13:9:23	999	339	594	615	632	182	686	715	737	777
263:13:10:23	999	336	593	615	632	182	687	714	737	775
263:13:11:23	1000	340	596	618	637	183	694	726	749	792
263:13:12:23	1011	339	596	616	634	183	689	716	742	779
263:13:13:23	1008	353	596	613	634	182	686	708	738	769
263:13:14:24	979	383	595	614	632	181	681	705	728	761
263:13:15:23	950	384	595	614	628	181	675	704	720	755
263:13:16:23	951	371	596	615	631	182	682	710	732	769
263:13:17:23	973	365	594	612	628	181	678	703	727	760
263:13:18:22	973	364	594	613	628	181	678	704	726	761
263:13:19:23	970	355	595	614	629	182	681	707	729	766
263:13:20:23	975	349	594	613	631	182	683	708	733	768
263:13:21:23	986	354	595	616	633	182	687	714	738	774
263:13:22:23	987	348	596	618	635	183	689	720	742	782
263:13:23:23	994	351	596	618	635	183	690	721	744	783
263:13:24:23	996	348	596	618	636	182	690	721	744	783
263:13:25:23	999	348	597	618	635	182	690	720	743	782
263:13:26:23	996	346	596	618	635	182	689	720	742	781
263:13:27:23	997	347	597	618	636	182	690	720	744	783
263:13:28:23	999	347	596	617	635	181	688	717	742	779
263:13:29:22	997	343	595	617	635	182	689	718	743	781
263:13:30:22	997	346	596	618	636	182	691	721	745	784
263:13:31:23	996	342	596	619	636	182	693	722	745	785
263:13:32:23	1005	360	596	616	635	181	688	715	744	778
263:13:33:23	1003	353	598	618	638	183	693	722	750	787
263:13:34:23	1003	358	597	617	638	182	692	720	748	783
263:13:35:23	997	355	597	616	636	182	688	716	744	777
263:13:36:23	988	355	599	620	639	182	694	726	750	789
263:13:37:23	998	350	598	618	637	182	691	720	747	782
263:13:38:23	994	355	598	620	637	183	692	723	747	785
263:13:39:23	997	355	597	618	637	182	690	720	745	782
263:13:40:23	998	348	597	619	637	182	692	723	748	786
263:13:41:23	1001	348	597	619	638	183	694	724	749	787
263:13:42:23	1001	349	597	620	638	183	695	727	751	791
263:13:43:23	1005	352	597	621	638	183	695	726	750	791
263:13:44:23	1005	348	597	621	639	183	695	726	749	790
263:13:45:22	1005	355	597	621	638	183	695	727	750	792
263:13:46:23	1009	347	596	621	638	184	694	725	749	789
263:13:47:23	1006	353	597	621	638	184	695	727	751	792
263:13:48:22	1009	354	597	621	638	184	694	725	750	789
263:13:49:23	1007	353	597	621	638	184	695	726	750	791
263:13:50:23	1009	347	597	621	638	184	695	726	750	790
263:13:51:23	1009	346	596	621	639	185	696	727	751	792

C28

130

DAY 263 1984 DATA.7:00-17:00

TIME DAY:HR:MI:SE	TE183 DEG F	TE184 DEG F	TE185 DEG F	TE186 DEG F	TE187 DEG F	TE188 DEG F	TE189 DEG F	TE190 DEG F	TE191 DEG F	TE192 DEG F
263:13:52:23	1010	351	597	621	638	184	694	725	749	709
263:13:53:23	1007	351	597	621	639	185	696	729	753	795
263:13:54:23	1013	349	596	621	638	185	696	727	751	792
263:13:55:23	1012	352	597	622	639	185	696	729	751	793
263:13:56:23	1014	345	597	620	639	185	695	725	751	790
263:13:57:23	1011	348	597	621	639	185	698	729	753	794
263:13:58:23	1014	350	597	621	639	185	698	730	754	796
263:13:59:24	1016	352	597	622	640	185	699	731	753	796
263:14: 0:23	1014	350	597	623	640	185	698	731	753	795
263:14: 1:24	1014	351	596	621	639	185	697	728	752	793
263:14: 2:24	1017	348	596	621	639	185	696	727	752	792
263:14: 3:23	1017	348	597	621	640	185	697	727	753	793
263:14: 4:23	1017	346	597	621	641	185	698	729	756	796
263:14: 5:23	1018	348	599	623	642	187	702	734	758	801
263:14: 6:23	1021	353	600	623	641	185	699	731	755	796
263:14: 7:23	1020	354	603	628	647	187	707	745	767	813
263:14: 8:22	1025	357	600	622	642	185	698	729	754	793
263:14: 9:24	1013	355	602	625	643	186	700	735	759	801
263:14:10:23	1016	355	600	621	642	185	698	727	757	792
263:14:11:23	1010	356	603	627	646	187	706	742	765	809
263:14:12:22	1016	359	601	622	642	186	699	729	757	793
263:14:13:23	1014	365	602	625	644	187	701	735	760	800
263:14:14:23	1014	374	606	631	650	188	710	749	771	817
263:14:15:23	1029	383	602	624	645	187	702	733	762	799
263:14:16:23	1018	383	603	626	645	187	702	736	760	800
263:14:17:23	1012	379	602	624	644	187	701	733	760	798
263:14:18:23	1015	378	602	623	643	186	700	731	759	797
263:14:19:23	1015	381	601	621	641	187	697	727	755	791
263:14:20:23	1011	371	601	621	642	186	699	728	757	793
263:14:21:23	1012	377	601	622	643	187	701	733	760	799
263:14:22:22	1018	373	602	623	644	187	702	733	761	800
263:14:23:23	1018	376	602	623	642	187	700	730	757	795
263:14:24:22	1014	376	603	626	646	187	705	740	765	806
263:14:25:22	1017	376	603	625	646	187	707	740	766	807
263:14:26:23	1022	369	601	621	643	186	700	729	759	793
263:14:27:23	1011	370	605	628	650	188	712	748	772	816
263:14:28:23	1023	369	602	621	645	186	702	732	762	796
263:14:29:24	1016	365	603	625	647	187	706	738	766	804
263:14:30:23	1014	366	603	625	647	188	705	736	765	801
263:14:31:22	1012	370	604	626	647	187	707	741	768	809
263:14:32:23	1019	373	601	621	643	187	701	728	761	795
263:14:33:24	1017	378	600	623	643	186	701	732	760	798
263:14:34:23	1016	381	601	624	644	187	703	733	763	800
263:14:35:23	1019	380	601	624	645	187	703	733	762	800
263:14:36:23	1018	376	602	625	646	187	706	737	766	805
263:14:37:23	1022	375	603	625	647	188	707	739	767	806
263:14:38:23	1023	372	603	624	647	188	707	737	766	802
263:14:39:22	1016	383	604	627	647	188	705	740	762	803
263:14:40:22	1013	380	603	626	647	188	707	740	766	805
263:14:41:23	1016	384	603	626	647	188	706	740	765	805
263:14:42:23	1017	374	603	625	646	187	706	737	765	803
263:14:43:23	1014	381	603	627	647	188	707	741	766	807
263:14:44:23	1015	382	603	627	648	188	708	742	768	809
263:14:45:22	1019	377	601	626	646	187	705	737	763	805
263:14:46:23	1018	380	600	625	644	187	704	735	761	800
263:14:47:22	1015	380	600	625	645	187	705	737	763	803

C29

TIME DAY:HR:MI:SE	TE183 DEG F	TE184 DEG F	TE185 DEG F	TE186 DEG F	TE187 DEG F	TE188 DEG F	TE189 DEG F	TE190 DEG F	TE191 DEG F	TE192 DEG F
263:14:48:22	1018	375	600	625	644	187	704	736	762	801
263:14:49:23	1019	371	599	624	644	187	704	736	761	801
263:14:50:23	1017	372	600	624	645	188	706	737	764	803
263:14:51:22	1016	375	600	625	645	188	706	738	763	805
263:14:52:23	1016	369	599	625	645	188	706	737	764	803
263:14:53:22	1018	366	600	625	646	188	707	738	764	804
263:14:54:23	1016	370	599	625	645	188	707	738	765	805
263:14:55:22	1017	371	599	625	646	188	708	741	766	807
263:14:56:23	1017	369	600	626	646	188	707	741	765	806
263:14:57:23	1015	389	603	632	650	190	713	752	772	819
263:14:58:23	986	383	593	610	628	184	674	687	717	735
263:14:59:23	908	410	597	619	634	186	684	714	732	768
263:15:0:23	926	413	594	614	630	184	679	702	725	754
263:15:1:23	921	396	594	616	630	185	680	706	725	759
263:15:2:22	923	392	593	614	629	185	680	704	725	757
263:15:3:23	929	389	594	614	630	185	681	705	727	760
263:15:4:23	926	391	595	613	629	184	676	699	721	751
263:15:5:23	918	388	594	614	629	184	676	701	721	753
263:15:6:23	921	379	594	613	629	185	678	702	724	754
263:15:7:23	924	382	594	613	629	185	678	703	724	755
263:15:8:23	922	373	593	612	629	184	678	702	723	754
263:15:9:24	923	373	592	612	628	184	677	702	722	753
263:15:10:23	924	373	591	613	629	185	679	703	724	755
263:15:11:23	923	371	591	612	628	184	677	702	721	753
263:15:12:23	926	371	591	612	630	185	681	705	727	759
263:15:13:23	933	374	593	615	633	185	683	711	730	765
263:15:14:23	939	365	593	616	635	187	688	715	736	772
263:15:15:22	948	373	594	618	636	187	691	720	740	778
263:15:16:22	953	368	594	619	637	187	692	722	741	779
263:15:17:23	961	374	595	619	638	187	693	723	744	780
263:15:18:23	968	372	596	621	642	188	700	730	753	791
263:15:19:22	979	376	595	621	644	188	703	735	757	797
263:15:20:22	986	384	595	618	641	187	696	725	748	784
263:15:21:22	980	396	595	619	641	187	698	728	753	788
263:15:22:22	981	388	595	618	641	187	698	728	752	788
263:15:23:22	983	391	596	621	644	188	703	737	759	799
263:15:24:22	996	390	596	621	645	188	704	737	761	800
263:15:25:22	996	386	596	621	644	187	702	733	758	795
263:15:26:22	990	380	596	619	643	187	700	730	756	791
263:15:27:22	989	383	595	621	644	187	702	734	759	797
263:15:28:22	996	375	595	620	642	187	702	733	759	797
263:15:29:22	997	374	595	620	642	187	702	733	759	798
263:15:30:22	1000	373	595	619	641	187	701	732	758	796
263:15:31:22	997	376	595	618	641	187	699	728	755	792
263:15:32:22	994	380	595	620	641	187	700	732	758	796
263:15:33:23	997	376	595	620	642	187	702	733	759	797
263:15:34:23	996	374	595	621	642	187	702	733	759	799
263:15:35:22	997	373	595	621	642	187	703	735	760	800
263:15:36:23	997	371	596	622	643	187	704	737	761	801
263:15:37:22	1000	374	595	621	641	187	700	733	757	795
263:15:38:23	998	372	595	618	641	187	700	729	757	793
263:15:39:22	996	384	594	618	641	187	700	730	756	794
263:15:40:22	997	376	593	620	641	187	700	733	758	797
263:15:41:24	1000	383	592	619	639	187	699	729	754	793
263:15:42:23	999	380	591	618	639	187	700	729	754	793
263:15:43:22	997	376	591	618	639	187	699	729	754	793

C30

132

DAY 263 1984 DATA.7:00-17:00

TIME DAY:HR:MI:SE	TE183 DEG F	TE184 DEG F	TE185 DEG F	TE186 DEG F	TE187 DEG F	TE188 DEG F	TE189 DEG F	TE190 DEG F	TE191 DEG F	TE192 DEG F
263:15:44:22	998	377	593	620	640	187	700	731	756	795
263:15:45:22	997	374	593	621	641	187	702	733	757	798
263:15:46:23	997	370	592	621	641	187	702	735	757	799
263:15:47:22	997	373	593	621	641	188	702	735	757	798
263:15:48:23	997	376	593	622	640	187	701	734	755	797
263:15:49:24	997	371	593	621	640	187	700	733	754	795
263:15:50:22	997	369	593	620	641	187	700	733	754	795
263:15:51:23	997	363	593	619	641	187	700	732	756	794
263:15:52:22	997	367	594	621	642	187	703	735	757	797
263:15:53:22	996	367	593	621	642	187	702	735	757	797
263:15:54:22	997	372	593	621	641	188	702	733	756	796
263:15:55:23	997	369	592	621	641	187	702	735	756	797
263:15:56:22	997	369	591	621	641	187	701	733	755	797
263:15:57:23	998	367	591	620	639	187	699	730	752	792
263:15:58:22	996	367	591	621	641	187	702	733	756	797
263:15:59:23	999	366	591	621	641	187	702	733	755	796
263:16: 0:22	999	363	589	619	639	187	700	731	753	795
263:16: 1:22	999	361	590	620	641	187	702	733	754	797
263:16: 2:22	998	364	589	620	640	187	702	735	754	798
263:16: 3:23	998	366	589	620	639	187	700	732	753	794
263:16: 4:23	996	364	590	620	640	187	700	732	753	795
263:16: 5:23	995	365	591	620	641	188	700	732	754	796
263:16: 6:23	997	365	591	620	641	187	701	733	756	796
263:16: 7:22	997	367	575	583	602	179	652	652	695	703
263:16: 8:23	962	363	567	572	563	173	593	589	616	610
263:16: 9:23	853	361	564	569	550	171	576	573	578	577
263:16:10:22	726	361	566	571	557	172	572	571	569	572
263:16:11:22	645	353	566	571	555	171	571	571	568	571
263:16:12:22	588	364	566	572	554	172	572	572	568	573
263:16:13:22	573	352	566	571	554	171	571	572	567	572
263:16:14:23	573	377	567	571	554	172	571	572	566	573
263:16:15:23	573	375	566	571	554	172	569	572	565	572
263:16:16:22	573	372	567	571	556	172	570	571	565	572
263:16:17:23	572	358	566	571	553	172	569	571	565	572
263:16:18:23	573	330	566	572	551	172	569	572	565	573
263:16:19:23	575	286	564	573	547	172	569	573	564	575
263:16:20:23	578	240	563	575	548	172	569	575	565	578
263:16:21:23	582	393	562	579	550	173	569	578	566	582
263:16:22:22	586	534	562	580	548	172	569	580	567	583
263:16:23:23	590	558	561	583	545	173	569	582	568	587
263:16:24:22	593	490	561	587	541	174	571	586	569	591
263:16:25:23	596	443	561	591	537	174	572	589	569	596
263:16:26:23	599	411	561	595	533	175	574	593	569	600
263:16:27:23	602	382	561	598	533	175	576	596	569	604
263:16:28:23	604	383	562	602	537	176	579	599	572	608
263:16:29:23	606	382	564	605	536	177	582	602	573	612
263:16:30:24	607	379	564	608	532	177	583	605	574	616
263:16:31:22	608	378	564	611	530	177	586	608	575	620
263:16:32:23	609	377	564	615	531	179	588	611	575	623
263:16:33:23	611	374	566	618	531	179	591	614	576	627
263:16:34:23	612	372	565	621	524	180	593	617	576	630
263:16:35:22	612	371	565	623	524	180	595	620	576	634
263:16:36:22	613	370	566	627	525	182	598	623	578	638
263:16:37:23	614	369	567	629	525	182	600	625	578	641
263:16:38:22	615	367	568	633	520	183	603	628	579	645
263:16:39:22	615	392	565	635	511	183	604	630	577	648

C31

133

TIME DAY:HR:MI:SE	TE193 DEC F	TE194 DEC F	TE195 DEC F	TE196 DEC F	TE197 DEC F	TE198 DEC F	SP.SALT DEC F	PT401 PSI	TE421 DEC F	PT431 PSI
263:12:0:33	583	582	582	582	580	586	924	1265	517	999
263:12:1:33	583	582	582	581	580	585	924	1271	525	996
263:12:2:33	582	582	581	581	580	585	924	1222	530	1006
263:12:3:33	583	581	581	581	580	584	924	1260	528	1000
263:12:4:34	583	581	582	581	579	584	924	1251	525	1000
263:12:5:33	581	579	580	578	579	582	924	1262	520	1000
263:12:6:33	577	575	576	574	575	579	924	1264	517	1001
263:12:7:33	579	581	582	581	580	584	924	1249	516	997
263:12:8:33	644	681	669	669	645	641	924	1243	517	1000
263:12:9:33	779	851	847	866	825	815	924	1257	520	1000
263:12:10:32	784	820	835	865	858	888	924	1260	522	1001
263:12:11:33	791	832	844	869	851	888	950	1243	523	1014
263:12:12:32	815	858	873	900	855	921	950	1232	522	1002
263:12:13:33	817	856	872	899	852	925	950	1256	522	989
263:12:14:33	828	872	889	915	866	938	975	1259	520	1006
263:12:15:33	836	878	897	924	877	953	985	1236	520	1008
263:12:16:32	843	886	905	933	897	961	985	1235	519	1001
263:12:17:33	845	887	906	935	898	967	995	1236	519	1000
263:12:18:33	852	894	914	942	919	971	1000	1257	518	1000
263:12:19:33	863	906	928	959	956	989	1000	1269	520	971
263:12:20:33	857	897	918	947	951	983	1000	1255	517	1056
263:12:21:33	854	896	918	945	952	977	1000	1232	500	1112
263:12:22:33	863	896	920	957	966	989	1000	1241	517	1082
263:12:23:33	855	893	917	945	956	984	1000	1249	524	1077
263:12:24:33	852	890	910	938	940	974	1000	1260	526	1061
263:12:25:33	860	900	922	951	947	984	1000	1233	522	1056
263:12:26:32	854	891	913	942	929	980	1000	1252	514	1062
263:12:27:33	856	895	917	945	911	980	1000	1231	511	1062
263:12:28:33	858	898	918	947	899	981	1000	1230	514	1054
263:12:29:33	858	899	920	949	891	983	1000	1258	518	1063
263:12:30:32	857	898	918	948	876	984	1000	1235	521	1060
263:12:31:33	858	898	919	949	883	984	1000	1230	524	1055
263:12:32:33	857	898	919	949	881	984	1000	1236	523	1063
263:12:33:33	856	896	917	948	876	984	1000	1256	521	1063
263:12:34:33	856	897	917	947	866	983	1000	1261	519	1071
263:12:35:33	858	900	920	951	871	986	1005	1239	519	1073
263:12:36:32	863	907	927	958	897	995	1005	1249	523	1074
263:12:37:33	865	909	930	958	931	994	1010	1245	525	1077
263:12:38:33	862	902	923	954	913	993	1015	1233	524	1072
263:12:39:33	866	910	931	960	907	994	1015	1222	522	1070
263:12:40:33	868	911	931	963	899	999	1020	1229	518	1070
263:12:41:33	873	918	938	969	887	1004	1020	1254	515	1071
263:12:42:33	872	916	936	968	891	1005	1020	1261	516	1069
263:12:43:33	870	913	934	965	914	1002	1020	1235	519	1070
263:12:44:33	884	930	951	982	970	1017	1020	1229	521	1077
263:12:45:33	872	912	935	966	969	1007	1020	1265	522	1072
263:12:46:34	873	914	936	966	973	1004	1020	1243	521	1068
263:12:47:33	878	921	944	973	979	1009	1020	1232	520	1070
263:12:48:33	867	904	927	956	957	997	1020	1251	519	1061
263:12:49:33	878	921	943	971	975	1005	1020	1229	515	1061
263:12:50:33	881	920	944	975	979	1016	1020	1248	511	1053
263:12:51:33	871	909	931	958	962	997	1020	1278	513	1065
263:12:52:33	882	926	948	977	981	1010	1020	1234	518	1063
263:12:53:34	871	907	931	960	970	1002	1020	1252	524	1067
263:12:54:32	878	919	942	971	979	1008	1020	1267	528	1070
263:12:55:33	880	922	944	972	982	1009	1020	1227	529	1070

C32

139



DAY 263 1984 DATA.7:00-17:00

TIME DAY:HR:MI:SE	TE193 DEC F	TE194 DEC F	TE195 DEC F	TE196 DEC F	TE197 DEC F	TE198 DEC F	SP.SALT DEC F	PT401 PSI	TE421 DEC F	PT431 PSI
263:12:56:32	876	913	937	967	980	1007	1020	1261	525	1068
263:12:57:33	860	893	918	944	951	987	1000	1238	520	1066
263:12:58:33	857	891	915	943	943	982	1000	1282	511	1070
263:12:59:33	861	897	919	948	935	985	1000	1238	510	995
263:13:0:32	857	892	915	944	915	985	1000	1231	502	959
263:13:1:33	859	897	918	947	892	984	1000	1221	503	918
263:13:2:33	861	900	921	952	887	989	1000	1238	508	893
263:13:3:33	859	899	920	951	882	989	1000	1260	513	882
263:13:4:34	857	898	918	949	871	987	1000	1196	516	903
263:13:5:33	858	899	918	948	862	986	1000	1274	521	961
263:13:6:33	858	898	919	950	866	987	1000	1258	531	1071
263:13:7:33	857	899	919	949	865	987	1000	1242	544	1078
263:13:8:32	856	897	918	950	859	989	1005	1237	543	1053
263:13:9:33	857	901	920	951	870	988	1005	1240	528	1061
263:13:10:32	859	901	921	952	884	989	1005	1243	513	1045
263:13:11:32	873	910	937	967	944	999	1010	1230	506	1043
263:13:12:33	869	909	931	964	947	1001	1015	1255	509	1038
263:13:13:33	861	896	918	949	941	992	1000	1253	514	1033
263:13:14:33	841	873	895	923	921	964	950	1245	521	1041
263:13:15:33	825	857	876	902	884	941	975	1234	524	1039
263:13:16:33	845	885	904	931	889	958	975	1268	524	1038
263:13:17:33	843	880	900	929	880	965	975	1242	521	1037
263:13:18:33	841	878	898	925	866	962	975	1256	520	1035
263:13:19:32	843	881	899	927	869	962	980	1263	517	1037
263:13:20:33	849	889	908	938	867	970	990	1261	518	1037
263:13:21:33	855	896	915	944	877	977	990	1269	518	1036
263:13:22:33	858	901	919	948	880	980	1000	1269	520	1035
263:13:23:33	863	906	925	954	884	986	1000	1267	520	1037
263:13:24:33	865	907	926	956	888	989	1000	1234	520	1036
263:13:25:33	865	906	925	954	885	989	1000	1237	520	1036
263:13:26:33	863	905	924	954	887	987	1000	1243	520	1035
263:13:27:33	865	906	926	955	895	989	1000	1256	520	1032
263:13:28:33	863	904	925	954	889	990	1000	1257	519	1032
263:13:29:32	865	906	925	953	875	987	1000	1283	518	1026
263:13:30:32	865	906	925	955	874	988	1000	1225	518	1027
263:13:31:33	869	913	931	958	921	989	1000	1267	519	1042
263:13:32:32	869	907	929	959	948	994	1000	1255	521	1032
263:13:33:33	872	912	933	960	960	993	1000	1242	520	1035
263:13:34:32	869	908	930	958	965	992	1000	1229	519	1021
263:13:35:32	864	900	921	949	942	985	1000	1276	519	1023
263:13:36:32	869	910	930	956	950	984	1000	1239	517	1036
263:13:37:32	868	905	926	955	941	989	1000	1271	520	1045
263:13:38:33	867	907	927	955	921	987	1000	1238	524	1060
263:13:39:34	867	907	927	955	907	989	1005	1251	526	1052
263:13:40:33	871	911	931	960	904	992	1005	1232	528	1032
263:13:41:33	872	912	931	960	900	993	1005	1253	518	946
263:13:42:33	874	916	936	965	904	996	1008	1245	501	971
263:13:43:32	875	917	936	965	891	997	1008	1257	501	1003
263:13:44:33	873	916	935	965	890	997	1010	1246	516	1013
263:13:45:33	875	919	937	967	878	999	1010	1238	525	1007
263:13:46:32	873	916	935	966	882	999	1010	1412	528	1007
263:13:47:33	875	918	936	966	889	997	1010	1342	526	1012
263:13:48:33	875	916	936	966	894	1000	1010	1298	522	1028
263:13:49:33	874	917	936	965	883	999	1012	1255	519	1043
263:13:50:33	874	917	937	968	882	1002	1012	1241	518	1048
263:13:51:33	876	920	939	968	885	1001	1012	1257	520	1046

C33

041

TIME DAY:HR:MI:SE	TE193 DEG F	TE194 DEG F	TE195 DEG F	TE196 DEG F	TE197 DEG F	TE198 DEG F	SP.SALT DEG F	PT401 PSI	TE421 DEG F	PT431 PSI
263:13:52:33	873	915	935	965	880	1000	1014	1254	520	1029
263:13:53:33	877	922	941	970	876	1002	1014	1244	520	1027
263:13:54:33	876	920	939	970	883	1004	1014	1251	518	1021
263:13:55:33	877	921	940	969	898	1003	1016	1250	517	1014
263:13:56:32	877	919	939	969	884	1005	1018	1235	517	1002
263:13:57:33	878	922	941	970	882	1003	1018	1242	517	996
263:13:58:33	879	923	944	975	883	1008	1018	1258	518	990
263:13:59:33	879	924	943	973	881	1007	1018	1233	517	989
263:14:0:33	877	922	942	972	883	1006	1018	1224	519	990
263:14:1:32	879	923	944	973	896	1006	1018	1270	520	981
263:14:2:33	879	923	943	973	890	1009	1018	1258	520	968
263:14:3:32	879	922	943	972	902	1006	1020	1244	517	965
263:14:4:33	881	925	945	975	910	1009	1020	1221	517	965
263:14:5:33	885	931	952	980	929	1011	1020	1262	517	966
263:14:6:33	883	925	947	977	944	1013	1020	1263	519	964
263:14:7:33	893	940	959	987	979	1018	1020	1228	520	967
263:14:8:33	883	922	945	976	979	1013	1020	1245	520	966
263:14:9:34	884	926	947	973	977	1004	1020	1240	520	966
263:14:10:33	885	923	945	974	973	1008	1020	1276	520	965
263:14:11:33	887	930	949	975	971	1004	1020	1251	519	965
263:14:12:33	884	922	945	975	952	1010	1020	1228	519	967
263:14:13:33	885	926	947	975	951	1006	1020	1247	520	970
263:14:14:32	897	943	962	990	981	1016	1020	1234	520	971
263:14:15:32	893	933	955	985	990	1020	1020	1284	521	969
263:14:16:33	884	924	945	973	975	1007	1020	1229	520	972
263:14:17:33	884	923	945	973	968	1005	1020	1226	520	974
263:14:18:33	886	925	947	975	958	1009	1020	1259	519	974
263:14:19:32	881	919	940	967	931	1002	1020	1260	519	973
263:14:20:32	883	921	941	970	927	1003	1020	1243	519	970
263:14:21:33	885	925	945	973	935	1006	1020	1243	519	976
263:14:22:32	888	927	948	977	943	1011	1020	1250	520	978
263:14:23:32	884	922	944	971	933	1007	1020	1238	521	983
263:14:24:33	889	930	950	978	957	1009	1020	1253	521	982
263:14:25:33	894	936	956	984	979	1014	1020	1253	520	986
263:14:26:32	884	918	941	970	962	1008	1020	1253	520	985
263:14:27:33	897	940	955	985	983	1011	1020	1244	520	985
263:14:28:33	891	927	950	981	984	1017	1020	1257	518	982
263:14:29:33	890	928	948	975	972	1007	1020	1236	518	980
263:14:30:33	888	925	947	975	961	1008	1020	1256	520	983
263:14:31:33	892	932	952	979	964	1008	1020	1247	520	981
263:14:32:33	889	926	948	977	937	1011	1020	1233	519	983
263:14:33:32	887	926	945	973	923	1005	1020	1250	520	983
263:14:34:32	890	928	949	977	928	1010	1020	1248	520	982
263:14:35:32	890	929	949	977	935	1010	1020	1249	520	986
263:14:36:32	891	931	952	980	939	1013	1020	1244	521	972
263:14:37:32	893	933	954	982	948	1016	1020	1232	518	955
263:14:38:32	891	929	950	979	945	1014	1020	1239	517	946
263:14:39:32	885	924	945	973	931	1007	1020	1250	516	942
263:14:40:32	889	928	949	977	930	1010	1020	1295	517	940
263:14:41:33	889	929	949	977	930	1010	1020	1279	518	938
263:14:42:33	888	927	948	977	925	1010	1020	1274	519	941
263:14:43:32	889	930	949	977	915	1008	1020	1280	521	944
263:14:44:33	891	933	953	983	907	1013	1020	1266	520	944
263:14:45:32	888	929	949	978	898	1011	1020	1231	521	943
263:14:46:32	886	926	947	977	894	1010	1020	1205	520	947
263:14:47:32	887	930	949	978	892	1009	1020	1211	520	943

C-34

141

DAY 263 1984 DATA.7:00-17:00

TIME DAY:HR:MI:SE	TE193 DEC F	TE194 DEC F	TE195 DEC F	TE196 DEC F	TE197 DEC F	TE198 DEC F	SP.SALT DEC F	PT401 PSI	TE421 DEC F	PT431 PSI
263:14:48:32	887	928	948	979	895	1011	1020	1242	519	944
263:14:49:33	885	925	945	976	901	1010	1020	1239	519	945
263:14:50:33	887	928	947	977	898	1011	1020	1280	521	946
263:14:51:32	886	928	947	976	898	1010	1020	1256	520	946
263:14:52:32	888	930	949	979	897	1011	1020	1231	519	946
263:14:53:32	887	928	947	977	894	1010	1020	1270	520	947
263:14:54:33	887	929	948	977	892	1010	1020	1237	519	944
263:14:55:33	889	932	951	981	899	1012	1020	1282	520	952
263:14:56:33	888	930	949	979	898	1010	1020	1289	519	953
263:14:57:33	894	941	959	987	939	1013	924	1239	520	947
263:14:58:33	832	842	871	894	876	955	924	1229	519	939
263:14:59:33	828	860	873	891	838	916	924	1274	517	926
263:15: 0:33	827	857	872	898	819	926	924	1226	518	922
263:15: 1:32	824	857	871	895	816	920	924	1195	517	907
263:15: 2:32	825	859	873	898	830	923	924	1225	516	899
263:15: 3:32	827	861	876	901	872	926	924	1187	517	891
263:15: 4:32	821	851	868	891	873	920	924	1266	517	888
263:15: 5:33	820	852	867	890	851	916	924	1278	518	885
263:15: 6:32	823	855	871	894	839	918	924	1207	518	881
263:15: 7:33	823	855	870	894	835	919	924	1289	519	880
263:15: 8:32	822	855	870	894	836	917	924	1203	520	879
263:15: 9:32	821	853	869	892	819	917	924	1308	520	880
263:15:10:32	823	857	871	895	815	918	924	1202	520	886
263:15:11:32	819	851	866	890	822	915	935	1270	521	892
263:15:12:32	828	862	878	901	842	921	935	1214	521	896
263:15:13:32	832	867	883	906	831	927	950	1290	521	897
263:15:14:32	840	877	892	917	842	937	960	1202	521	895
263:15:15:32	844	883	898	923	852	944	960	1291	520	894
263:15:16:33	851	889	905	930	857	949	965	1212	519	896
263:15:17:32	853	893	910	936	878	955	975	1293	518	897
263:15:18:33	865	906	923	948	903	964	975	1235	519	896
263:15:19:32	871	912	931	956	940	973	985	1206	520	896
263:15:20:32	865	902	922	948	947	973	990	1228	520	895
263:15:21:33	868	905	924	948	943	971	990	1201	520	901
263:15:22:33	867	903	924	948	924	972	990	1307	519	903
263:15:23:32	876	916	935	959	940	979	995	1297	521	905
263:15:24:32	883	922	943	968	964	990	995	1199	521	907
263:15:25:33	878	913	935	959	962	984	1000	1278	520	906
263:15:26:33	875	910	931	955	927	979	1000	1189	520	908
263:15:27:32	880	918	937	962	913	983	1000	1249	520	906
263:15:28:33	880	917	938	964	912	990	1000	1261	519	902
263:15:29:32	881	921	940	966	916	991	1000	1193	519	898
263:15:30:32	880	919	938	965	919	993	1000	1276	518	899
263:15:31:32	876	912	932	958	906	989	1000	1256	520	901
263:15:32:32	879	919	937	963	909	989	1000	1264	520	903
263:15:33:32	880	919	937	963	904	990	1000	1223	520	909
263:15:34:33	881	921	939	966	895	992	1000	1239	521	919
263:15:35:32	880	920	938	965	898	992	1000	1266	522	956
263:15:36:32	881	923	941	967	904	993	1000	1281	525	1011
263:15:37:32	878	918	937	964	909	993	1000	1239	531	1057
263:15:38:32	879	918	937	964	893	991	1000	1250	533	1061
263:15:39:32	877	917	935	962	879	989	1000	1263	529	1040
263:15:40:32	879	921	937	965	852	992	1000	1252	523	1047
263:15:41:32	876	919	936	965	853	993	1000	1208	517	1102
263:15:42:32	875	918	934	962	857	991	1000	1265	520	1073
263:15:43:33	876	918	-999	963	861	990	1000	1259	536	1081

C35

171

DAY 263 1984 DATA.7:00-17:00

TIME DAY:HR:MI:SE	TE193 DEC F	TE194 DEC F	TE195 DEC F	TE196 DEC F	TE197 DEC F	TE198 DEC F	SP.SALT DEC F	PT401 PSI	TE421 DEC F	PT431 PSI
263:15:44:32	876	918	935	963	871	991	1000	1230	541	1093
263:15:45:33	876	921	937	965	848	992	1000	1260	535	1081
263:15:46:32	876	922	937	966	844	992	1000	1245	532	1081
263:15:47:32	877	922	938	967	854	992	1000	1254	523	1082
263:15:48:32	876	921	938	966	868	992	1000	1267	513	1078
263:15:49:33	876	919	937	965	867	990	1000	1261	506	1080
263:15:50:32	876	919	937	964	884	989	1000	1222	505	1070
263:15:51:32	879	920	939	965	888	990	1000	1255	508	1065
263:15:52:33	878	919	938	964	885	988	1000	1282	520	1078
263:15:53:33	878	920	938	964	882	987	1000	1258	543	1079
263:15:54:32	879	921	939	966	877	988	1000	1236	550	1094
263:15:55:32	878	922	938	965	858	987	1000	1230	551	1082
263:15:56:33	879	923	939	968	868	990	1000	1250	539	1077
263:15:57:33	876	917	936	963	872	987	1000	1252	510	1076
263:15:58:32	879	921	939	965	869	986	1000	1273	485	1064
263:15:59:32	879	921	939	966	855	989	1000	1256	477	1068
263:16: 0:32	877	920	937	965	847	989	1000	1273	503	1054
263:16: 1:32	876	920	937	965	845	989	1000	1262	536	1040
263:16: 2:32	876	922	938	965	845	987	1000	1248	542	1022
263:16: 3:32	876	919	936	964	866	986	1000	1248	542	1006
263:16: 4:33	875	917	935	962	874	984	1000	1254	540	994
263:16: 5:32	878	921	939	964	891	985	1000	1249	540	985
263:16: 6:32	879	921	939	965	884	988	1000	1256	539	1038
263:16: 7:33	823	834	865	892	815	949	924	1244	538	1057
263:16: 8:33	693	691	712	750	690	834	924	1250	536	1070
263:16: 9:33	605	605	608	634	591	710	924	1252	537	1080
263:16:10:32	580	584	578	595	548	642	924	1244	536	1072
263:16:11:32	562	576	558	581	521	605	924	1251	536	1074
263:16:12:32	556	578	554	580	513	593	924	1250	536	1072
263:16:13:32	552	576	551	579	510	587	924	1244	536	1072
263:16:14:33	550	576	551	578	510	585	924	1267	518	1072
263:16:15:32	549	575	550	576	511	582	924	1263	510	1082
263:16:16:32	548	575	549	576	510	581	924	1236	508	1083
263:16:17:33	546	575	547	576	506	580	924	1251	510	1031
263:16:18:32	541	576	545	578	501	581	924	1251	510	993
263:16:19:33	535	579	540	581	493	585	924	1249	522	953
263:16:20:33	538	582	546	585	503	588	924	1250	529	915
263:16:21:32	540	586	548	591	506	593	924	1249	529	885
263:16:22:32	539	590	546	596	501	597	924	1225	525	859
263:16:23:32	537	594	543	601	496	601	924	1232	523	792
263:16:24:33	535	598	541	605	491	605	924	1243	524	662
263:16:25:32	532	604	537	610	482	609	924	1220	507	637
263:16:26:33	529	609	534	615	478	614	924	1398	456	395
263:16:27:34	531	614	536	620	484	618	924	1213	424	215
263:16:28:33	540	619	544	624	500	623	924	1089	406	206
263:16:29:33	540	624	545	629	499	627	924	1367	401	202
263:16:30:33	538	628	541	633	492	630	924	1293	400	199
263:16:31:32	538	632	541	636	492	634	924	1262	401	195
263:16:32:33	539	636	542	639	495	637	924	205	402	194
263:16:33:33	541	641	543	644	498	641	924	204	406	193
263:16:34:32	539	646	540	647	491	644	924	203	411	192
263:16:35:32	539	650	539	650	491	648	924	203	413	192
263:16:36:33	541	654	541	654	496	651	924	202	418	192
263:16:37:33	542	659	541	658	496	654	924	201	420	191
263:16:38:32	540	662	538	661	490	658	924	201	423	191
263:16:39:32	535	666	533	664	483	660	924	201	426	190

C36

743

DAY 263 1984 DATA.7:00-17:00

TIME DAY:HR:MI:SE	FT432 PSI	FCV431 PERCENT	LT471 INCH	FY472 INCH	TE451 DEC F	PT321 PSI	TT521 DEC F	IE401 PERCENT	IE421 PERCENT	IE432 PERCENT
263:12:0:33	159	51	16	16	362	1021	96	37	27	100
263:12:1:33	170	58	16	16	363	1024	97	38	27	100
263:12:2:33	178	54	16	16	366	1024	99	35	24	100
263:12:3:33	185	55	16	16	369	1022	99	39	21	100
263:12:4:34	193	56	16	16	372	1024	100	39	19	100
263:12:5:33	204	60	16	16	375	1021	101	40	19	100
263:12:6:33	212	56	16	16	379	1026	102	41	19	100
263:12:7:33	220	54	16	16	383	1022	103	39	20	100
263:12:8:33	228	53	16	16	386	1024	105	40	21	100
263:12:9:33	236	53	16	16	389	1024	107	41	21	99
263:12:10:32	243	53	16	16	392	1028	108	41	21	95
263:12:11:33	242	43	16	16	394	1036	110	43	20	95
263:12:12:32	243	63	16	16	395	1022	113	40	19	92
263:12:13:33	241	55	16	16	395	1013	114	42	18	92
263:12:14:33	238	56	16	16	395	1028	115	40	18	94
263:12:15:33	238	48	16	16	395	1030	116	40	18	95
263:12:16:32	240	50	16	16	395	1022	118	40	18	94
263:12:17:33	238	36	16	16	396	1019	120	41	18	96
263:12:18:33	239	35	16	16	395	1019	122	42	19	96
263:12:19:33	250	87	16	15	395	1026	122	42	19	90
263:12:20:33	244	57	15	15	396	1096	118	38	18	92
263:12:21:33	239	52	15	15	396	1140	125	36	21	94
263:12:22:33	237	51	15	15	396	1113	127	39	23	95
263:12:23:33	237	52	15	15	395	1110	129	38	22	95
263:12:24:33	240	58	15	15	396	1101	131	41	21	93
263:12:25:33	240	63	15	15	395	1103	133	37	19	95
263:12:26:32	241	61	16	16	395	1103	135	38	20	93
263:12:27:33	239	62	16	16	396	1109	113	37	22	95
263:12:28:33	242	61	16	16	395	1103	112	35	24	93
263:12:29:33	239	61	16	16	396	1107	110	37	25	94
263:12:30:32	239	62	16	16	396	1103	109	37	25	95
263:12:31:33	241	62	17	17	396	1103	108	34	24	94
263:12:32:33	240	61	17	17	396	1105	108	36	22	94
263:12:33:33	239	60	17	17	396	1105	108	37	22	94
263:12:34:33	241	56	17	17	396	1108	107	37	21	92
263:12:35:33	241	50	17	17	396	1105	107	37	22	92
263:12:36:32	239	52	17	17	396	1105	107	40	21	94
263:12:37:33	241	50	17	17	396	1105	107	39	20	92
263:12:38:33	241	52	17	17	396	1103	106	38	19	93
263:12:39:33	241	51	17	17	396	1105	106	39	18	92
263:12:40:33	240	54	16	16	396	1101	106	37	18	94
263:12:41:33	238	53	16	16	396	1105	106	38	19	94
263:12:42:33	242	51	16	16	395	1103	106	42	20	91
263:12:43:33	242	53	16	16	395	1105	106	38	20	93
263:12:44:33	237	54	16	16	396	1108	114	38	20	95
263:12:45:33	240	51	16	16	396	1103	123	41	20	91
263:12:46:34	243	53	15	16	396	1103	126	39	19	92
263:12:47:33	237	55	16	16	396	1105	129	37	19	95
263:12:48:33	242	60	16	16	395	1105	132	40	19	92
263:12:49:33	239	63	16	16	395	1110	134	35	20	94
263:12:50:33	242	60	16	16	395	1101	137	36	22	92
263:12:51:33	238	60	16	16	396	1105	124	40	24	93
263:12:52:33	240	59	16	16	396	1105	129	36	25	93
263:12:53:34	242	53	16	16	396	1103	131	39	24	91
263:12:54:32	238	53	16	16	396	1105	132	41	22	93
263:12:55:33	241	54	16	16	396	1103	132	37	20	93

C37

149

TIME DAY:HR:MI:SE	FT432 PSI	FCV491 PERCENT	LT471 INCH	FY472 INCH	TE451 DEC F	PT321 PSI	TT521 DEC F	IE401 PERCENT	IE421 PERCENT	IE432 PERCENT
263:12:56:32	239	54	16	16	396	1101	126	40	18	92
263:12:57:33	238	62	16	16	396	1105	132	37	17	94
263:12:58:33	242	56	16	16	396	1103	133	40	18	91
263:12:59:33	238	58	16	16	395	1065	128	39	21	94
263:13:0:32	238	63	16	16	395	1039	128	33	26	94
263:13:1:33	241	65	16	16	395	1005	131	36	31	92
263:13:2:33	239	66	16	16	396	978	132	41	35	94
263:13:3:33	239	66	16	16	395	965	129	39	37	94
263:13:4:34	238	61	16	16	396	978	129	26	38	94
263:13:5:33	237	43	16	16	395	1019	129	39	38	95
263:13:6:33	233	25	16	16	395	1119	130	34	36	100
263:13:7:33	231	32	16	16	394	1132	131	35	30	100
263:13:8:32	232	45	16	16	393	1113	131	35	23	100
263:13:9:33	233	40	16	16	393	1115	130	35	19	100
263:13:10:32	233	43	16	16	394	1103	130	35	20	100
263:13:11:32	233	45	16	16	393	1105	130	33	23	100
263:13:12:33	233	44	16	16	393	1103	130	36	26	100
263:13:13:33	233	43	16	16	393	1102	122	36	29	100
263:13:14:33	233	43	16	16	393	1107	121	34	29	100
263:13:15:33	233	43	16	16	394	1107	121	35	28	100
263:13:16:33	233	43	16	16	393	1105	122	38	27	100
263:13:17:33	233	43	16	16	394	1105	125	35	26	100
263:13:18:33	233	43	16	16	393	1103	126	36	26	100
263:13:19:32	233	43	16	16	394	1105	128	35	26	100
263:13:20:33	233	43	16	16	393	1105	129	38	26	100
263:13:21:33	233	43	16	16	393	1103	131	36	27	100
263:13:22:33	233	43	16	16	393	1103	131	36	27	100
263:13:23:33	233	42	16	16	393	1105	132	36	27	100
263:13:24:33	233	42	16	16	393	1105	130	34	27	100
263:13:25:33	233	42	16	16	393	1105	130	34	27	100
263:13:26:33	233	42	16	16	393	1105	130	34	27	100
263:13:27:33	233	42	16	16	393	1103	130	35	27	100
263:13:28:33	233	44	16	16	393	1103	130	35	27	100
263:13:29:32	235	45	16	16	393	1101	130	37	27	100
263:13:30:32	232	45	16	16	393	1101	128	33	28	100
263:13:31:33	232	39	16	16	393	1111	124	37	28	100
263:13:32:32	232	45	16	16	393	1105	122	36	28	100
263:13:33:33	235	43	16	16	393	1108	122	34	27	99
263:13:34:32	232	46	16	16	393	1096	121	34	27	100
263:13:35:32	236	45	16	16	393	1098	120	34	27	99
263:13:36:32	231	42	16	16	393	1105	120	35	28	100
263:13:37:32	236	23	16	16	394	1105	119	34	28	100
263:13:38:33	235	0	15	15	394	1109	119	36	27	100
263:13:39:34	231	1	15	15	394	1101	119	36	25	100
263:13:40:33	225	46	15	15	393	1100	119	35	23	100
263:13:41:33	234	64	15	15	392	1039	119	36	22	100
263:13:42:33	234	53	15	15	393	1052	119	37	25	100
263:13:43:32	233	44	15	15	393	1079	119	36	31	100
263:13:44:33	233	44	15	15	393	1092	119	34	34	100
263:13:45:33	233	45	15	15	393	1086	119	32	33	100
263:13:46:32	233	46	16	16	393	1084	119	1	31	100
263:13:47:33	233	46	16	16	393	1090	119	31	29	100
263:13:48:33	233	45	16	16	393	1105	120	36	27	100
263:13:49:33	233	45	16	16	393	1121	120	34	27	100
263:13:50:33	233	43	16	16	393	1124	120	34	27	100
263:13:51:33	233	43	16	16	393	1121	120	37	28	100

C38

150

DAY 263 1984 DATA.7:00-17:00

TIME DAY:HR:MI:SE	PT432 PSI	FCV431 PERCENT	LT471 INCH	FY472 INCH	TE451 DEC F	PT321 PSI	TT521 DEC F	IE401 PERCENT	IE421 PERCENT	IE432 PERCENT
263:13:52:33	233	44	16	16	393	1105	120	35	28	100
263:13:53:33	233	44	16	16	393	1105	120	35	28	100
263:13:54:33	233	43	16	16	393	1103	120	35	28	100
263:13:55:33	233	44	16	16	393	1098	120	34	28	100
263:13:56:32	233	44	16	16	393	1088	120	33	29	100
263:13:57:33	233	44	16	16	393	1083	119	34	29	100
263:13:58:33	233	44	16	16	393	1077	120	35	30	100
263:13:59:33	233	44	16	16	393	1079	120	33	31	100
263:14:0:33	233	44	16	16	393	1077	120	34	31	100
263:14:1:32	233	44	16	16	393	1071	120	38	31	100
263:14:2:33	233	45	16	16	393	1059	120	37	31	100
263:14:3:32	233	46	16	16	393	1057	120	35	31	100
263:14:4:33	233	45	16	16	393	1057	120	36	32	100
263:14:5:33	233	44	16	16	393	1059	120	38	32	100
263:14:6:33	233	44	16	16	393	1057	120	36	32	100
263:14:7:33	233	44	16	16	393	1059	120	30	32	100
263:14:8:33	233	44	16	16	393	1059	120	30	32	100
263:14:9:34	233	45	16	16	393	1059	120	32	32	100
263:14:10:33	233	44	16	16	393	1059	120	39	32	100
263:14:11:33	233	44	16	16	393	1057	120	36	32	100
263:14:12:33	233	44	16	16	393	1057	120	34	32	100
263:14:13:33	233	44	16	16	393	1063	120	34	32	100
263:14:14:32	233	44	16	16	393	1063	120	35	32	100
263:14:15:32	233	44	16	16	393	1061	120	31	32	100
263:14:16:33	233	44	16	16	393	1063	120	30	32	100
263:14:17:33	233	44	16	16	393	1067	120	30	32	100
263:14:18:33	233	44	16	16	393	1067	120	37	32	100
263:14:19:32	233	44	16	16	393	1067	120	35	32	100
263:14:20:32	233	44	16	16	393	1065	120	36	32	100
263:14:21:33	233	44	16	16	393	1068	120	36	32	100
263:14:22:32	233	43	16	16	393	1070	120	27	32	100
263:14:23:32	233	43	16	16	393	1077	120	34	32	100
263:14:24:33	233	44	16	16	393	1077	120	34	31	100
263:14:25:33	233	44	16	16	393	1081	120	35	31	100
263:14:26:32	233	43	16	16	393	1081	120	36	31	100
263:14:27:33	233	44	16	16	393	1079	120	38	31	100
263:14:28:33	233	44	16	16	393	1077	120	33	31	100
263:14:29:33	233	44	16	16	393	1079	120	35	31	100
263:14:30:33	233	44	16	16	393	1077	120	32	31	100
263:14:31:33	233	43	16	16	393	1077	120	34	31	100
263:14:32:33	233	44	16	16	393	1078	120	34	31	100
263:14:33:32	233	44	16	16	393	1077	120	35	31	100
263:14:34:32	233	44	16	16	393	1076	120	35	31	100
263:14:35:32	233	43	16	16	393	1081	120	34	31	100
263:14:36:32	233	43	16	16	393	1069	120	36	31	100
263:14:37:32	233	45	16	16	393	1055	120	31	31	100
263:14:38:32	233	46	16	16	393	1046	120	35	32	100
263:14:39:32	233	45	16	16	393	1044	120	38	33	100
263:14:40:32	233	45	16	16	393	1041	120	40	34	100
263:14:41:33	233	45	16	16	393	1039	120	31	34	100
263:14:42:33	233	44	16	16	393	1044	120	32	35	100
263:14:43:32	233	44	16	16	393	1044	120	33	34	100
263:14:44:33	233	45	16	16	393	1046	120	32	34	100
263:14:45:32	233	45	16	16	393	1046	120	26	34	100
263:14:46:32	233	45	16	16	393	1048	120	28	34	100
263:14:47:32	233	45	16	16	393	1044	120	33	33	100

C39

151

TIME DAY:HR:MI:SE	PT432 PSI	FCV431 PERCENT	LT471 INCH	FY472 INCH	TE451 DEC F	PT321 PSI	TT521 DEC F	IE401 PERCENT	IE421 PERCENT	IE432 PERCENT
263:14:48:32	233	45	16	16	393	1046	120	38	34	100
263:14:49:33	233	45	16	16	393	1048	120	37	34	100
263:14:50:33	233	45	16	16	393	1048	120	41	34	100
263:14:51:32	233	45	16	16	393	1048	120	30	34	100
263:14:52:32	233	45	16	16	393	1046	120	28	34	100
263:14:53:32	233	45	16	16	393	1046	120	34	33	100
263:14:54:33	233	45	16	16	393	1044	120	36	33	100
263:14:55:33	233	44	16	16	393	1050	120	42	34	100
263:14:56:33	233	44	16	16	393	1050	120	33	34	100
263:14:57:33	233	44	16	16	393	1044	120	31	34	100
263:14:58:33	233	45	16	16	393	1037	120	27	34	100
263:14:59:33	233	45	16	16	393	1028	120	37	34	100
263:15:0:33	233	45	16	16	393	1022	120	34	34	100
263:15:1:32	233	45	16	16	393	1011	120	28	35	100
263:15:2:32	233	46	16	16	393	1003	120	31	36	100
263:15:3:32	233	47	16	16	393	994	120	22	37	100
263:15:4:32	233	46	16	16	393	990	120	38	37	100
263:15:5:33	233	47	16	16	393	986	120	42	38	100
263:15:6:32	233	47	16	16	393	982	120	22	38	100
263:15:7:33	233	47	16	16	393	982	120	37	38	100
263:15:8:32	233	47	16	16	393	980	120	21	38	100
263:15:9:32	233	47	16	16	393	980	120	40	38	100
263:15:10:32	233	47	16	16	393	986	120	26	38	100
263:15:11:32	233	46	16	16	393	990	120	34	38	100
263:15:12:32	233	46	16	16	393	994	120	37	38	100
263:15:13:32	233	46	16	16	393	994	120	22	37	100
263:15:14:32	233	46	16	16	393	992	120	42	37	100
263:15:15:32	233	46	16	16	393	992	120	21	36	100
263:15:16:33	233	46	16	16	393	992	120	42	37	100
263:15:17:32	233	46	16	16	393	996	120	23	37	100
263:15:18:33	233	46	16	16	393	992	120	38	37	100
263:15:19:32	233	46	16	16	393	994	120	30	37	100
263:15:20:32	233	46	16	16	393	990	120	38	37	100
263:15:21:33	233	44	16	16	393	996	120	34	37	100
263:15:22:33	233	43	16	16	393	995	120	23	37	100
263:15:23:32	233	43	16	16	393	1000	120	42	37	100
263:15:24:32	233	43	16	16	393	1001	120	33	37	100
263:15:25:33	233	44	16	16	393	1001	120	30	36	100
263:15:26:33	233	44	15	15	393	1001	120	34	36	100
263:15:27:32	233	44	15	16	393	1002	120	22	36	100
263:15:28:33	233	45	16	16	393	998	120	45	37	100
263:15:29:32	233	46	16	16	393	996	120	31	37	100
263:15:30:32	233	46	16	16	393	994	120	38	37	100
263:15:31:32	233	45	16	16	393	998	120	25	37	100
263:15:32:32	233	45	16	16	393	1000	120	42	37	100
263:15:33:32	233	45	16	16	393	1003	120	26	37	100
263:15:34:33	233	45	16	16	393	1013	120	41	37	100
263:15:35:32	233	43	16	16	393	1040	120	27	37	100
263:15:36:32	233	40	16	16	393	1086	120	30	36	100
263:15:37:32	233	37	16	16	393	1129	120	34	33	100
263:15:38:32	233	38	16	16	393	1130	120	35	29	100
263:15:39:32	233	40	16	16	393	1108	120	36	26	100
263:15:40:32	233	41	16	16	393	1105	120	37	24	100
263:15:41:32	233	39	16	16	393	1132	120	31	24	100
263:15:42:32	234	34	16	16	394	1098	120	41	25	100
263:15:43:33	233	32	16	16	393	1103	118	40	22	100

C40

152



DAY 263 1984 DATA.7:00-17:00

TIME DAY:HR:MI:SE	PT432 PSI	FCV431 PERCENT	LT471 INCH	FY472 INCH	TE451 DEC F	PT321 PSI	TT521 DEC F	IE401 PERCENT	IE421 PERCENT	IE432 PERCENT
263:15:44:32	232	34	16	16	393	1110	117	39	16	100
263:15:45:33	237	51	16	16	393	1098	116	42	11	98
263:15:46:32	240	54	17	17	394	1096	112	42	7	97
263:15:47:32	245	57	17	17	395	1098	112	43	5	94
263:15:48:32	243	54	17	17	396	1094	109	42	5	91
263:15:49:33	242	54	17	17	396	1098	107	42	9	91
263:15:50:32	238	49	17	17	396	1086	101	41	13	92
263:15:51:32	236	16	17	17	395	1074	98	43	17	96
263:15:52:33	235	0	17	17	395	1086	97	45	18	99
263:15:53:33	238	10	17	17	395	1086	95	47	14	99
263:15:54:32	241	30	17	17	395	1103	94	46	6	98
263:15:55:32	245	54	17	17	395	1096	92	46	1	93
263:15:56:33	241	52	17	17	396	1090	91	43	1	93
263:15:57:33	239	48	17	17	396	1086	89	43	1	94
263:15:58:32	238	39	17	17	396	1073	89	45	9	94
263:15:59:32	237	8	17	17	395	1079	87	44	21	96
263:16: 0:32	235	0	16	16	395	1061	86	48	30	100
263:16: 1:32	237	0	17	17	395	1048	85	47	28	100
263:16: 2:32	239	0	17	17	395	1030	85	47	22	100
263:16: 3:32	239	0	17	17	395	1013	94	47	15	100
263:16: 4:33	240	0	17	17	395	1001	98	48	9	100
263:16: 5:32	240	0	17	17	395	990	97	47	3	100
263:16: 6:32	235	0	17	17	395	1044	96	47	1	100
263:16: 7:33	232	0	17	17	395	1061	96	47	1	100
263:16: 8:33	229	0	17	17	393	1075	96	47	1	100
263:16: 9:33	227	0	17	17	393	1086	96	47	1	100
263:16:10:32	226	3	17	17	392	1077	95	47	1	100
263:16:11:32	223	1	17	17	391	1079	94	47	1	100
263:16:12:32	222	4	17	17	391	1077	94	47	1	100
263:16:13:32	220	3	17	17	390	1079	94	45	1	100
263:16:14:33	220	5	16	16	389	1079	94	44	1	100
263:16:15:32	216	6	16	16	389	1088	94	46	3	100
263:16:16:32	214	1	16	16	388	1088	94	46	6	100
263:16:17:33	215	0	16	16	387	1037	94	47	9	100
263:16:18:32	215	0	16	16	387	1000	94	47	12	100
263:16:19:33	216	0	16	16	387	961	94	46	13	100
263:16:20:33	216	0	17	17	387	920	94	46	11	100
263:16:21:32	216	0	17	17	387	892	94	47	8	100
263:16:22:32	216	0	17	17	387	867	94	47	6	100
263:16:23:32	215	0	16	16	387	851	94	42	5	100
263:16:24:33	211	0	16	16	387	876	94	42	4	100
263:16:25:32	209	0	16	16	386	857	94	40	5	100
263:16:26:33	207	0	15	15	385	855	94	23	16	100
263:16:27:34	203	0	14	14	385	859	94	26	40	100
263:16:28:33	199	0	13	13	383	887	94	7	71	100
263:16:29:33	195	0	12	12	382	961	94	35	100	100
263:16:30:33	192	0	12	12	380	986	94	40	100	100
263:16:31:32	189	0	12	12	379	955	94	42	100	100
263:16:32:33	187	0	12	12	378	936	94	0	100	100
263:16:33:33	187	0	13	13	377	918	94	0	100	100
263:16:34:32	186	0	13	13	377	905	94	0	100	100
263:16:35:32	186	0	13	13	376	889	94	0	100	100
263:16:36:33	185	0	13	13	376	876	93	0	100	100
263:16:37:33	185	0	13	13	376	867	93	0	100	100
263:16:38:32	184	0	13	13	375	853	94	0	100	100
263:16:39:32	184	0	13	13	375	843	93	0	100	100

C41

153

TIME DAY:HR:MI:SE	CA432B PERCENT	IE435 PERCENT	IE471 PERCENT	IE472 PERCENT	IE451 PERCENT	IE452 PERCENT	IE491 PERCENT	IE521 PERCENT	ZT581 PERCENT	CT480 MIO/CM
263:12: 0:33	0	0	23	0	0	0	100	0	39	0
263:12: 1:33	0	0	16	0	0	0	100	0	0	0
263:12: 2:33	0	0	7	0	0	0	100	0	38	0
263:12: 3:33	0	0	1	0	0	0	100	0	38	0
263:12: 4:34	0	0	1	0	0	0	100	0	38	0
263:12: 5:33	0	0	1	0	0	0	100	0	20	0
263:12: 6:33	0	0	1	0	0	0	100	0	38	0
263:12: 7:33	0	0	2	0	0	0	100	0	38	0
263:12: 8:33	0	0	1	0	0	0	100	0	38	0
263:12: 9:33	0	0	1	0	0	0	100	0	38	0
263:12:10:32	3	0	1	0	0	0	100	0	38	0
263:12:11:33	4	0	2	0	0	0	100	0	39	0
263:12:12:32	7	1	2	0	0	0	100	0	26	0
263:12:13:33	8	0	3	0	0	0	100	0	37	0
263:12:14:33	8	0	5	0	0	0	100	0	38	0
263:12:15:33	5	0	9	0	0	0	100	0	70	0
263:12:16:32	5	0	14	0	0	0	100	0	99	0
263:12:17:33	5	0	20	0	0	0	100	0	99	0
263:12:18:33	4	0	29	0	0	0	100	0	99	0
263:12:19:33	5	6	38	0	0	0	100	0	99	0
263:12:20:33	6	1	49	0	0	0	100	0	99	0
263:12:21:33	7	0	63	0	0	0	100	0	99	0
263:12:22:33	9	0	79	0	0	0	100	0	99	0
263:12:23:33	9	0	98	5	0	0	100	0	99	0
263:12:24:33	6	1	100	0	0	0	100	0	99	0
263:12:25:33	6	0	100	0	0	0	100	0	99	0
263:12:26:32	7	0	100	0	0	0	100	0	99	0
263:12:27:33	7	0	100	0	0	0	100	0	99	0
263:12:28:33	5	1	99	0	0	0	100	0	99	0
263:12:29:33	7	0	93	0	0	0	100	0	99	0
263:12:30:32	6	0	83	0	0	0	100	0	99	0
263:12:31:33	6	1	70	0	0	0	100	0	99	0
263:12:32:33	6	0	52	0	0	0	100	0	99	0
263:12:33:33	7	0	31	0	0	0	100	0	99	0
263:12:34:33	7	0	11	0	0	0	100	0	99	0
263:12:35:33	8	0	1	0	0	0	100	0	99	0
263:12:36:32	6	0	1	0	0	0	100	0	99	0
263:12:37:33	8	0	1	0	0	0	100	0	99	0
263:12:38:33	6	1	1	0	0	0	100	0	99	0
263:12:39:33	8	1	1	0	0	0	100	0	99	0
263:12:40:33	6	1	1	0	0	0	100	0	99	0
263:12:41:33	9	0	1	0	0	0	100	0	99	0
263:12:42:33	8	2	1	0	0	0	100	0	99	0
263:12:43:33	6	0	3	0	0	0	100	0	99	0
263:12:44:33	9	0	7	0	0	0	100	100	99	0
263:12:45:33	9	2	14	0	0	0	100	100	99	0
263:12:46:34	7	2	24	0	0	0	100	100	99	0
263:12:47:33	9	0	32	0	0	0	100	100	99	0
263:12:48:33	5	2	36	0	0	0	100	99	99	0
263:12:49:33	6	0	36	0	0	0	100	97	99	0
263:12:50:33	6	1	34	0	0	0	100	94	99	0
263:12:51:33	8	0	29	0	0	0	100	95	99	0
263:12:52:33	8	0	23	0	0	0	100	97	99	0
263:12:53:34	7	2	21	0	0	0	100	97	99	0
263:12:54:32	9	0	22	0	0	0	100	96	99	0
263:12:55:33	7	1	25	0	0	0	100	94	99	0

CAN

DAY 263 1984 DATA.7:00-17:00

TIME DAY:HR:MI:SE	CA432B PERCENT	IE435 PERCENT	IE471 PERCENT	IE472 PERCENT	IE451 PERCENT	IE452 PERCENT	IE491 PERCENT	IE521 PERCENT	ZT581 PERCENT	CT480 MHO/CM
263:12:56:32	7	1	27	0	0	0	100	96	99	0
263:12:57:33	8	0	25	0	0	0	100	96	99	0
263:12:58:33	7	1	26	0	0	0	100	95	99	0
263:12:59:33	9	0	27	0	0	0	100	94	99	0
263:13:0:32	7	0	27	0	0	0	100	96	99	0
263:13:1:33	6	1	20	0	0	0	100	96	99	0
263:13:2:33	6	0	27	0	0	0	100	95	99	0
263:13:3:33	7	0	25	0	0	0	100	94	99	0
263:13:4:34	8	0	27	0	0	0	100	95	99	0
263:13:5:33	6	0	27	0	0	0	100	96	99	0
263:13:6:33	1	0	27	0	0	0	100	95	99	0
263:13:7:33	0	0	27	0	0	0	100	95	99	0
263:13:8:32	0	0	26	0	0	0	100	94	99	0
263:13:9:33	0	0	27	0	0	0	100	94	99	0
263:13:10:32	0	0	28	0	0	0	100	94	99	0
263:13:11:32	0	0	28	0	0	0	100	94	99	0
263:13:12:33	0	0	29	0	0	0	100	93	99	0
263:13:13:33	0	0	30	0	0	0	100	70	99	0
263:13:14:33	0	0	31	0	0	0	100	76	99	0
263:13:15:33	0	0	30	0	0	0	100	81	99	0
263:13:16:33	0	0	30	0	0	0	100	86	99	0
263:13:17:33	0	0	31	0	0	0	100	91	99	0
263:13:18:33	0	0	31	0	0	0	100	93	99	0
263:13:19:32	0	0	30	0	0	0	100	95	99	0
263:13:20:33	0	0	31	0	0	0	100	96	99	0
263:13:21:33	0	0	30	0	0	0	100	95	99	0
263:13:22:33	0	0	29	0	0	0	100	95	99	0
263:13:23:33	0	0	29	0	0	0	100	94	99	0
263:13:24:33	0	0	29	0	0	0	100	93	99	0
263:13:25:33	0	0	29	0	0	0	100	93	99	0
263:13:26:33	0	0	29	0	0	0	100	93	99	0
263:13:27:33	0	0	29	0	0	0	100	92	99	0
263:13:28:33	0	0	28	0	0	0	100	92	99	0
263:13:29:32	0	0	27	0	0	0	100	92	99	0
263:13:30:32	0	0	25	0	0	0	100	86	99	0
263:13:31:33	0	0	26	0	0	0	100	82	99	0
263:13:32:32	0	0	25	0	0	0	100	80	99	0
263:13:33:33	1	0	26	0	0	0	100	79	99	0
263:13:34:32	0	0	26	0	0	0	100	78	99	0
263:13:35:32	1	0	26	0	0	0	100	78	99	0
263:13:36:32	0	0	28	0	0	0	100	78	99	0
263:13:37:32	0	0	37	0	0	0	100	78	99	0
263:13:38:33	0	0	55	0	0	0	100	79	99	0
263:13:39:34	0	0	87	100	0	0	100	79	99	0
263:13:40:33	0	0	100	100	0	0	100	80	99	0
263:13:41:33	0	0	100	89	0	0	100	81	99	0
263:13:42:33	0	0	100	14	0	0	100	82	99	0
263:13:43:32	0	0	100	0	0	0	100	82	99	0
263:13:44:33	0	0	100	0	0	0	100	83	99	0
263:13:45:33	0	0	100	0	0	0	100	84	99	0
263:13:46:32	0	0	100	0	0	0	100	84	99	0
263:13:47:33	0	0	100	0	0	0	100	85	99	0
263:13:48:33	0	0	100	0	0	0	100	85	99	0
263:13:49:33	0	0	100	0	0	0	100	85	99	0
263:13:50:33	0	0	100	0	0	0	100	85	99	0
263:13:51:33	0	0	100	0	0	0	100	85	99	0

C43

160

TIME DAY:HR:MI:SE	CA432B PERCENT	IE435 PERCENT	IE471 PERCENT	IE472 PERCENT	IE451 PERCENT	IE452 PERCENT	IE491 PERCENT	IE521 PERCENT	ZT581 PERCENT	CT480 MHO/CM
263:13:52:33	0	0	100	0	0	0	100	85	99	0
263:13:53:33	0	0	100	0	0	0	100	85	99	0
263:13:54:33	0	0	100	0	0	0	100	85	99	0
263:13:55:33	0	0	100	0	0	0	100	84	99	0
263:13:56:32	0	0	100	0	0	0	100	84	99	0
263:13:57:33	0	0	100	0	0	0	100	85	99	0
263:13:58:33	0	0	99	0	0	0	100	85	99	0
263:13:59:33	0	0	99	0	0	0	100	86	99	0
263:14: 0:33	0	0	98	0	0	0	100	86	99	0
263:14: 1:32	0	0	97	0	0	0	100	86	99	0
263:14: 2:33	0	0	95	0	0	0	100	86	99	0
263:14: 3:32	0	0	94	0	0	0	100	86	99	0
263:14: 4:33	0	0	92	0	0	0	100	86	99	0
263:14: 5:33	0	0	92	0	0	0	100	85	99	0
263:14: 6:33	0	0	92	0	0	0	100	85	99	0
263:14: 7:33	0	0	92	0	0	0	100	85	99	0
263:14: 8:33	0	0	91	0	0	0	100	85	99	0
263:14: 9:34	0	0	91	0	0	0	100	85	99	0
263:14:10:33	0	0	91	0	0	0	100	86	99	0
263:14:11:33	0	0	91	0	0	0	100	86	99	0
263:14:12:33	0	0	90	0	0	0	100	85	99	0
263:14:13:33	0	0	92	0	0	0	100	85	99	0
263:14:14:32	0	0	92	0	0	0	100	85	99	0
263:14:15:32	0	0	92	0	0	0	100	85	99	0
263:14:16:33	0	0	93	0	0	0	100	85	99	0
263:14:17:33	0	0	94	0	0	0	100	85	99	0
263:14:18:33	0	0	95	0	0	0	100	85	99	0
263:14:19:32	0	0	95	0	0	0	100	85	99	0
263:14:20:32	0	0	97	0	0	0	100	85	99	0
263:14:21:33	0	0	98	0	0	0	100	85	99	0
263:14:22:32	0	0	99	0	0	0	100	85	99	0
263:14:23:32	0	0	100	0	0	0	100	85	99	0
263:14:24:33	0	0	100	0	0	0	100	85	99	0
263:14:25:33	0	0	100	0	0	0	100	85	99	0
263:14:26:32	0	0	100	0	0	0	100	85	99	0
263:14:27:33	0	0	100	0	0	0	100	85	99	0
263:14:28:33	0	0	100	0	0	0	100	85	99	0
263:14:29:33	0	0	100	0	0	0	100	85	99	0
263:14:30:33	0	0	100	0	0	0	100	85	99	0
263:14:31:33	0	0	100	0	0	0	100	85	99	0
263:14:32:33	0	0	100	0	0	0	100	85	99	0
263:14:33:32	0	0	100	0	0	0	100	85	99	0
263:14:34:32	0	0	100	0	0	0	100	85	99	0
263:14:35:32	0	0	100	0	0	0	100	85	99	0
263:14:36:32	0	0	100	0	0	0	100	84	99	0
263:14:37:32	0	0	100	0	0	0	100	84	99	0
263:14:38:32	0	0	100	0	0	0	100	85	99	0
263:14:39:32	0	0	100	0	0	0	100	85	99	0
263:14:40:32	0	0	100	0	0	0	100	85	99	0
263:14:41:33	0	0	100	0	0	0	100	85	99	0
263:14:42:33	0	0	100	0	0	0	100	85	99	0
263:14:43:32	0	0	100	0	0	0	100	85	99	0
263:14:44:33	0	0	100	0	0	0	100	85	99	0
263:14:45:32	0	0	100	0	0	0	100	84	99	0
263:14:46:32	0	0	100	0	0	0	100	84	99	0
263:14:47:32	0	0	100	0	0	0	100	84	99	0

CA4

DAY 263 1984 DATA.7:00-17:00

TIME DAY:HR:MI:SE	CA432B PERCENT	IE435 PERCENT	IE471 PERCENT	IE472 PERCENT	IE451 PERCENT	IE452 PERCENT	IE491 PERCENT	IE521 PERCENT	ZT581 PERCENT	GT480 MHO/CM
263:14:48:32	0	0	100	0	0	0	100	84	99	0
263:14:49:33	0	0	100	0	0	0	100	84	99	0
263:14:50:33	0	0	100	0	0	0	100	84	99	0
263:14:51:32	0	0	100	0	0	0	100	84	99	0
263:14:52:32	0	0	100	0	0	0	100	84	99	0
263:14:53:32	0	0	100	0	0	0	100	84	99	0
263:14:54:33	0	0	100	0	0	0	100	84	99	0
263:14:55:33	0	0	100	0	0	0	100	84	99	0
263:14:56:33	0	0	100	0	0	0	100	84	99	0
263:14:57:33	0	0	100	0	0	0	100	83	99	0
263:14:58:33	0	0	100	0	0	0	100	84	99	0
263:14:59:33	0	0	100	0	0	0	100	84	99	0
263:15:0:33	0	0	100	0	0	0	100	84	99	0
263:15:1:32	0	0	100	0	0	0	100	84	99	0
263:15:2:32	0	0	100	0	0	0	100	84	99	0
263:15:3:32	0	0	100	0	0	0	100	84	99	0
263:15:4:32	0	0	100	0	0	0	100	83	99	0
263:15:5:33	0	0	100	0	0	0	100	83	99	0
263:15:6:32	0	0	100	0	0	0	100	83	99	0
263:15:7:33	0	0	100	0	0	0	100	83	99	0
263:15:8:32	0	0	100	0	0	0	100	83	99	0
263:15:9:32	0	0	100	0	0	0	100	84	99	0
263:15:10:32	0	0	100	0	0	0	100	84	99	0
263:15:11:32	0	0	100	0	0	0	100	84	99	0
263:15:12:32	0	0	100	0	0	0	100	84	99	0
263:15:13:32	0	0	100	0	0	0	100	84	99	0
263:15:14:32	0	0	100	0	0	0	100	84	99	0
263:15:15:32	0	0	100	0	0	0	100	84	99	0
263:15:16:33	0	0	100	0	0	0	100	83	99	0
263:15:17:32	0	0	100	0	0	0	100	83	99	0
263:15:18:33	0	0	100	0	0	0	100	83	99	0
263:15:19:32	0	0	100	0	0	0	100	84	99	0
263:15:20:32	0	0	100	0	0	0	100	84	99	0
263:15:21:33	0	0	100	0	0	0	100	84	99	0
263:15:22:33	0	0	100	0	0	0	100	84	99	0
263:15:23:32	0	0	100	0	0	0	100	84	99	0
263:15:24:32	0	0	100	0	0	0	100	83	99	0
263:15:25:33	0	0	100	0	0	0	100	83	99	0
263:15:26:33	0	0	100	0	0	0	100	83	99	0
263:15:27:32	0	0	100	0	0	0	100	83	99	0
263:15:28:33	0	0	100	0	0	0	100	83	99	0
263:15:29:32	0	0	100	0	0	0	100	83	99	0
263:15:30:32	0	0	100	0	0	0	100	83	99	0
263:15:31:32	0	0	100	0	0	0	100	83	99	0
263:15:32:32	0	0	100	0	0	0	100	84	99	0
263:15:33:32	0	0	100	0	0	0	100	83	99	0
263:15:34:33	0	0	100	0	0	0	100	83	99	0
263:15:35:32	0	0	100	0	0	0	100	83	99	0
263:15:36:32	0	0	100	0	0	0	100	83	99	0
263:15:37:32	0	0	100	0	0	0	100	83	99	0
263:15:38:32	0	0	100	0	0	0	100	83	99	0
263:15:39:32	0	0	100	0	0	0	100	83	99	0
263:15:40:32	0	0	100	0	0	0	100	83	99	0
263:15:41:32	0	0	100	0	0	0	100	83	99	0
263:15:42:32	0	0	100	0	0	0	100	83	99	0
263:15:43:33	0	0	100	0	0	0	100	84	99	0

CAS

162

TIME DAY:HR:MI:SE	CA432B PERCENT	IE435 PERCENT	IE471 PERCENT	IE472 PERCENT	IE451 PERCENT	IE452 PERCENT	IE491 PERCENT	IE521 PERCENT	ZT581 PERCENT	CT480 MHO/CM
263:15:44:32	0	0	100	0	0	0	100	84	99	0
263:15:45:33	2	0	93	0	0	0	100	84	29	0
263:15:46:32	2	0	77	0	0	0	100	84	0	0
263:15:47:32	4	1	1	0	0	0	100	84	0	0
263:15:48:32	9	0	1	0	0	0	100	84	0	0
263:15:49:33	8	0	1	0	0	0	100	84	0	0
263:15:50:32	9	0	1	0	0	0	100	84	0	0
263:15:51:32	5	0	1	0	0	0	100	84	0	0
263:15:52:33	2	0	1	0	0	0	100	84	0	0
263:15:53:33	1	0	1	0	0	0	100	84	0	0
263:15:54:32	1	0	1	0	0	0	100	84	0	0
263:15:55:32	7	0	1	0	0	0	100	84	0	0
263:15:56:33	8	0	1	0	0	0	100	84	0	0
263:15:57:33	7	0	1	0	0	0	100	84	0	0
263:15:58:32	8	0	1	0	0	0	100	84	0	0
263:15:59:32	4	0	1	0	0	0	100	84	0	0
263:16: 0:32	0	0	1	0	0	0	100	84	0	0
263:16: 1:32	0	0	1	0	0	0	100	84	0	0
263:16: 2:32	0	0	1	0	0	0	100	84	0	0
263:16: 3:32	0	0	1	0	0	0	100	84	0	0
263:16: 4:33	0	0	1	0	0	0	100	84	0	0
263:16: 5:32	0	0	1	0	0	0	100	84	0	0
263:16: 6:32	0	0	1	0	0	0	100	84	0	0
263:16: 7:33	0	0	1	0	0	0	100	84	0	0
263:16: 8:33	0	0	1	0	0	0	100	84	0	0
263:16: 9:33	0	0	1	0	0	0	100	84	0	0
263:16:10:32	0	0	1	0	0	0	100	84	0	0
263:16:11:32	0	0	1	0	0	0	100	84	0	0
263:16:12:32	0	0	1	0	0	0	100	84	0	0
263:16:13:32	0	0	1	0	0	0	100	84	0	0
263:16:14:33	0	0	1	0	0	0	100	84	0	0
263:16:15:32	0	0	1	0	0	0	100	84	0	0
263:16:16:32	0	0	1	0	0	0	100	84	0	0
263:16:17:33	0	0	1	0	0	0	100	84	0	0
263:16:18:32	0	0	1	0	0	0	100	84	0	0
263:16:19:33	0	0	1	0	0	0	100	84	0	0
263:16:20:33	0	0	1	0	0	0	100	84	0	0
263:16:21:32	0	0	1	0	0	0	99	84	0	0
263:16:22:32	0	0	1	0	0	0	69	84	0	0
263:16:23:32	0	0	1	0	0	0	0	84	0	0
263:16:24:33	0	0	1	0	0	0	0	84	0	0
263:16:25:32	0	0	1	0	0	0	0	84	0	0
263:16:26:33	0	0	1	0	0	0	0	84	0	0
263:16:27:34	0	0	1	100	0	0	0	84	0	0
263:16:28:33	0	0	1	100	0	0	1	84	0	0
263:16:29:33	0	0	1	100	0	0	75	84	0	0
263:16:30:33	0	0	1	100	0	0	100	84	0	0
263:16:31:32	0	0	1	100	0	0	100	84	0	0
263:16:32:33	0	0	1	100	0	0	100	84	0	0
263:16:33:33	0	0	1	100	0	0	100	84	0	0
263:16:34:32	0	0	1	100	0	0	100	84	0	0
263:16:35:32	0	0	1	100	0	0	99	84	0	0
263:16:36:33	0	0	1	100	0	0	81	84	0	0
263:16:37:33	0	0	1	100	0	0	43	84	0	0
263:16:38:32	0	0	1	100	0	0	0	84	0	0
263:16:39:32	0	0	1	100	0	0	0	84	0	0

C46

DAY 263 1984 DATA.7:00-17:00

TIME DAY:HR:MI:SE	CT482 MHO/CM	PHT480 PERCENT	TE581 DEG F	PT481 PSI	PT482 PSI	PT483 PSI	PT484 PSI	FT481 KLB/HR	FT482 KLB/HR	TE481 DEC F
263:11:59:43	0	1	141	171	169	1034	92	90	149	361
263:12:0:43	0	1	139	172	170	1029	95	94	148	362
263:12:1:43	0	1	137	183	181	1028	92	94	148	364
263:12:2:43	0	1	150	191	189	1035	92	95	147	368
263:12:3:43	0	1	139	198	196	1026	92	95	147	371
263:12:4:43	0	1	134	207	205	1029	92	94	147	374
263:12:5:44	0	1	137	217	216	1029	91	94	147	377
263:12:6:43	0	1	139	224	223	1027	91	94	147	380
263:12:7:43	0	1	133	233	231	1030	91	93	146	384
263:12:8:43	0	1	132	241	239	1029	91	94	146	387
263:12:9:43	0	1	130	249	247	1031	92	94	146	390
263:12:10:43	0	1	124	255	254	1029	91	93	145	393
263:12:11:43	0	1	117	256	254	1040	92	94	145	395
263:12:12:43	0	1	117	257	255	1033	92	95	145	395
263:12:13:43	0	1	155	250	248	1030	92	94	144	396
263:12:14:43	0	1	132	253	251	1029	87	94	144	396
263:12:15:43	0	1	118	252	250	1032	92	93	144	396
263:12:16:44	0	1	116	253	251	1030	91	94	145	396
263:12:17:43	0	1	125	250	248	1031	92	93	145	396
263:12:18:43	0	1	123	251	249	1027	91	90	145	396
263:12:19:43	0	1	120	254	252	1052	92	94	146	396
263:12:20:44	0	1	121	252	250	1135	92	93	145	397
263:12:21:43	0	1	119	255	253	1148	92	94	144	396
263:12:22:43	0	1	118	252	250	1135	92	94	144	396
263:12:23:43	0	1	118	253	251	1130	92	92	144	396
263:12:24:43	0	1	118	249	247	1134	92	92	145	396
263:12:25:43	0	1	117	254	252	1132	91	90	145	396
263:12:26:43	0	1	117	250	248	1136	92	90	145	396
263:12:27:43	0	1	117	254	252	1138	90	92	145	396
263:12:28:43	0	1	117	251	249	1139	92	90	146	396
263:12:29:43	0	1	117	251	249	1144	91	92	145	396
263:12:30:42	0	1	117	253	251	1131	91	91	145	396
263:12:31:43	0	1	117	253	251	1135	92	90	145	396
263:12:32:42	0	1	117	253	251	1134	92	91	145	396
263:12:33:43	0	1	117	250	249	1135	92	91	145	396
263:12:34:43	0	1	117	253	251	1129	92	93	145	396
263:12:35:44	0	1	119	251	249	1128	92	94	144	396
263:12:36:43	0	1	120	252	251	1122	91	93	144	396
263:12:37:43	0	1	122	252	250	1130	92	94	144	396
263:12:38:43	0	1	123	254	251	1124	92	93	144	396
263:12:39:43	0	1	125	250	247	1130	91	94	144	396
263:12:40:43	0	1	126	254	252	1124	92	94	145	396
263:12:41:43	0	1	127	251	249	1124	91	95	144	396
263:12:42:43	0	1	127	249	247	1122	91	94	144	396
263:12:43:44	0	1	128	255	253	1125	91	93	144	396
263:12:44:43	0	1	129	252	250	1130	91	94	144	396
263:12:45:43	0	1	130	249	247	1127	92	94	143	396
263:12:46:43	0	1	132	252	250	1125	92	93	145	396
263:12:47:44	0	1	135	251	249	1126	91	91	144	396
263:12:48:43	0	1	136	251	249	1139	93	91	145	396
263:12:49:43	0	1	137	253	251	1140	93	92	145	396
263:12:50:43	0	1	136	251	249	1139	86	91	145	396
263:12:51:43	0	1	137	251	248	1136	92	92	145	396
263:12:52:43	0	1	137	254	252	1135	92	94	144	396
263:12:53:44	0	1	137	253	250	1126	91	92	145	396
263:12:54:44	0	1	138	251	249	1123	89	94	144	396

C47

TIME DAY:HR:MI:SE	CT482 MHO/CM	PHT480 PERCENT	TE581 DEG F	PT481 PSI	PT482 PSI	PT483 PSI	PT484 PSI	FT481 KLB/HR	FT482 KLB/HR	TE481 DEC F
263:12:55:43	0	1	139	254	252	1126	91	94	144	396
263:12:56:43	0	1	140	249	247	1126	92	91	145	396
263:12:57:43	0	1	140	254	251	1135	92	94	144	396
263:12:58:43	0	1	141	249	247	1126	92	92	145	396
263:12:59:43	0	1	131	252	250	1111	90	91	145	396
263:13:0:43	0	1	127	253	251	1094	92	91	145	396
263:13:1:43	0	1	126	253	251	1059	91	91	144	396
263:13:2:44	0	1	126	253	251	1032	92	91	145	396
263:13:3:43	0	1	127	253	251	1020	92	93	144	396
263:13:4:43	0	1	129	253	250	1036	93	92	145	396
263:13:5:44	0	1	130	249	247	1073	97	90	145	396
263:13:6:43	0	1	132	244	243	1167	92	91	146	395
263:13:7:43	0	1	132	243	241	1148	92	90	146	394
263:13:8:43	0	1	132	244	242	1150	92	93	145	394
263:13:9:43	0	1	132	245	243	1149	92	90	146	394
263:13:10:43	0	1	132	245	243	1143	92	92	146	394
263:13:11:43	0	1	132	245	243	1146	92	92	146	394
263:13:12:42	0	1	132	245	243	1143	92	90	146	393
263:13:13:43	0	1	132	245	243	1144	92	91	145	394
263:13:14:44	0	1	132	245	243	1150	89	91	145	393
263:13:15:43	0	1	133	245	243	1147	89	92	147	394
263:13:16:43	0	1	132	245	243	1147	88	90	146	393
263:13:17:43	0	1	132	245	243	1149	89	91	146	393
263:13:18:43	0	1	133	245	243	1146	89	91	146	394
263:13:19:43	0	1	133	245	243	1148	85	91	146	393
263:13:20:43	0	1	134	245	243	1145	79	91	146	394
263:13:21:43	0	1	134	245	243	1143	87	91	146	394
263:13:22:42	0	1	134	245	243	1141	87	91	146	394
263:13:23:43	0	1	134	245	243	1145	86	90	146	394
263:13:24:43	0	1	134	245	243	1147	87	92	146	394
263:13:25:43	0	1	134	244	243	1147	87	92	146	394
263:13:26:43	0	1	135	245	243	1147	89	92	146	394
263:13:27:43	0	1	136	245	243	1143	87	91	146	394
263:13:28:43	0	1	136	245	243	1147	87	91	146	394
263:13:29:43	0	1	138	246	244	1148	86	92	146	394
263:13:30:43	0	1	141	245	242	1148	100	93	145	394
263:13:31:43	0	1	144	244	242	1140	85	91	146	394
263:13:32:43	0	1	147	244	242	1150	87	91	146	394
263:13:33:42	0	1	149	246	244	1152	87	91	146	394
263:13:34:43	0	1	152	244	242	1139	88	91	147	394
263:13:35:42	0	1	156	248	246	1145	87	91	146	394
263:13:36:43	0	1	159	244	242	1144	88	93	145	394
263:13:37:44	0	1	157	247	245	1134	86	92	145	394
263:13:38:43	0	1	152	247	245	1135	88	94	146	394
263:13:39:43	0	1	148	242	240	1126	85	87	146	394
263:13:40:42	0	1	146	238	236	1140	87	91	146	393
263:13:41:43	0	1	147	246	244	1097	87	91	146	393
263:13:42:42	0	1	147	246	244	1104	87	90	146	394
263:13:43:43	0	1	148	245	243	1128	87	90	146	394
263:13:44:42	0	1	148	244	242	1138	88	91	146	394
263:13:45:43	0	1	147	245	243	1133	88	92	147	394
263:13:46:43	0	1	147	245	243	1133	87	86	147	393
263:13:47:43	0	1	147	245	243	1140	87	87	147	393
263:13:48:42	0	1	147	245	243	1150	88	89	146	393
263:13:49:43	0	1	146	245	243	1166	88	91	147	394
263:13:50:42	0	1	145	244	243	1169	87	91	146	394

C48

170



DAY 263 1984 DATA.7:00-17:00

TIME DAY:HR:MI:SE	CT482 MHO/CM	PHT480 PERCENT	TE581 DEG F	PT481 PSI	PT482 PSI	PT483 PSI	PT484 PSI	FT481 KLB/HR	FT482 KLB/HR	TE481 DEC F
263:13:51:43	0	1	145	244	243	1159	86	90	146	393
263:13:52:42	0	1	145	244	243	1152	87	91	146	393
263:13:53:43	0	1	145	244	243	1151	87	90	146	394
263:13:54:42	0	1	146	244	243	1147	88	91	146	393
263:13:55:43	0	1	146	245	243	1144	87	91	146	394
263:13:56:43	0	1	147	245	243	1137	62	91	146	393
263:13:57:43	0	1	149	245	243	1131	89	91	146	393
263:13:58:44	0	1	150	244	243	1122	88	90	146	393
263:13:59:43	0	1	151	244	243	1126	85	90	146	394
263:14: 0:43	0	1	152	245	243	1127	88	92	146	394
263:14: 1:43	0	1	153	244	243	1116	88	92	146	394
263:14: 2:43	0	1	155	245	243	1109	87	91	146	394
263:14: 3:43	0	1	155	245	243	1109	87	91	146	393
263:14: 4:42	0	1	156	245	243	1110	87	91	146	393
263:14: 5:43	0	1	156	245	243	1110	88	91	146	394
263:14: 6:42	0	1	156	244	243	1104	86	91	146	394
263:14: 7:43	0	1	156	245	243	1109	88	91	146	394
263:14: 8:42	0	1	156	245	243	1108	87	91	146	394
263:14: 9:43	0	1	156	245	243	1107	87	91	146	394
263:14:10:42	0	1	156	245	243	1103	87	91	146	394
263:14:11:43	0	1	156	245	243	1105	87	91	146	394
263:14:12:43	0	1	156	245	243	1112	87	91	146	394
263:14:13:42	0	1	157	244	243	1112	88	91	146	393
263:14:14:44	0	1	157	244	243	1111	85	91	147	394
263:14:15:43	0	1	157	245	243	1110	87	91	146	394
263:14:16:43	0	1	158	245	243	1116	87	91	146	394
263:14:17:43	0	1	158	244	243	1119	88	92	146	394
263:14:18:43	0	1	158	245	243	1116	87	91	146	393
263:14:19:43	0	1	159	245	243	1111	81	90	146	394
263:14:20:43	0	1	159	245	243	1111	87	91	146	394
263:14:21:44	0	1	159	244	243	1120	87	92	146	394
263:14:22:43	0	1	159	245	243	1123	87	91	146	393
263:14:23:43	0	1	159	245	242	1126	87	91	146	393
263:14:24:43	0	1	159	244	243	1124	83	91	147	394
263:14:25:43	0	1	160	245	243	1125	85	92	147	393
263:14:26:43	0	1	159	245	243	1124	87	90	147	393
263:14:27:43	0	1	160	244	243	1124	87	91	146	393
263:14:28:43	0	1	160	244	243	1126	89	91	146	393
263:14:29:43	0	1	161	245	243	1122	87	91	146	393
263:14:30:42	0	1	162	245	243	1126	87	91	146	394
263:14:31:43	0	1	162	245	243	1126	87	90	146	394
263:14:32:42	0	1	162	245	243	1124	87	91	147	394
263:14:33:43	0	1	163	244	242	1122	87	90	146	393
263:14:34:42	0	1	163	245	243	1124	87	91	146	393
263:14:35:43	0	1	164	245	243	1129	87	91	147	394
263:14:36:43	0	1	163	244	242	1116	88	91	147	393
263:14:37:42	0	1	163	245	243	1107	87	92	146	393
263:14:38:42	0	1	164	245	243	1097	87	91	146	394
263:14:39:43	0	1	165	244	243	1091	85	90	146	394
263:14:40:42	0	1	166	245	243	1089	86	90	146	394
263:14:41:43	0	1	166	245	243	1092	86	91	146	393
263:14:42:43	0	1	166	245	243	1097	87	91	147	394
263:14:43:43	0	1	165	245	243	1098	86	91	147	394
263:14:44:43	0	1	166	244	243	1099	86	91	146	394
263:14:45:43	0	1	167	245	243	1099	87	91	146	393
263:14:46:43	0	1	167	245	243	1102	82	93	147	393

C49

171

TIME DAY:HR:MI:SE	CT482 MHO/CM	PHT400 PERCENT	TE501 DEC F	PT481 PSI	PT402 PSI	PT483 PSI	PT484 PSI	FT481 KLB/HR	FT482 KLB/HR	TE481 DEC F
263:14:47:43	0	1	167	244	243	1099	88	91	146	394
263:14:48:43	0	1	168	245	243	1095	87	90	147	394
263:14:49:42	0	1	170	245	243	1096	87	91	146	394
263:14:50:42	0	1	170	245	243	1096	86	91	147	393
263:14:51:43	0	1	171	244	243	1102	86	92	146	394
263:14:52:42	0	1	172	245	243	1101	87	91	146	394
263:14:53:42	0	1	172	245	243	1100	87	91	146	394
263:14:54:42	0	1	173	245	243	1097	87	91	147	394
263:14:55:44	0	1	173	245	243	1100	87	90	146	393
263:14:56:43	0	1	174	244	243	1105	87	92	147	394
263:14:57:43	0	1	174	245	243	1102	88	92	147	393
263:14:58:43	0	1	173	244	243	1097	86	92	146	394
263:14:59:43	0	1	173	245	243	1081	87	91	147	393
263:15:0:42	0	1	174	245	243	1083	84	92	146	394
263:15:1:42	0	1	174	244	242	1074	87	92	146	393
263:15:2:42	0	1	175	244	242	1065	88	92	146	393
263:15:3:43	0	1	175	244	243	1060	86	92	147	393
263:15:4:43	0	1	175	245	243	1047	88	90	147	394
263:15:5:42	0	1	175	245	243	1046	87	91	147	393
263:15:6:42	0	1	175	244	243	1049	87	92	146	393
263:15:7:43	0	1	176	245	243	1038	87	90	147	393
263:15:8:43	0	1	176	244	243	1047	87	93	146	393
263:15:9:43	0	1	176	245	243	1038	87	90	146	393
263:15:10:43	0	1	177	244	243	1052	86	93	147	394
263:15:11:42	0	1	176	245	243	1046	86	90	147	393
263:15:12:42	0	1	176	244	243	1058	83	93	147	393
263:15:13:43	0	1	175	244	242	1048	87	89	146	393
263:15:14:43	0	1	175	244	243	1055	87	92	147	393
263:15:15:43	0	1	175	245	243	1045	86	91	147	393
263:15:16:42	0	1	175	244	242	1057	86	92	147	394
263:15:17:43	0	1	175	245	243	1047	87	90	147	394
263:15:18:43	0	1	174	244	243	1055	86	92	147	393
263:15:19:42	0	1	174	245	243	1047	87	90	147	393
263:15:20:43	0	1	173	245	243	1054	87	92	147	394
263:15:21:42	0	1	172	245	243	1055	88	92	147	394
263:15:22:43	0	1	171	245	243	1052	87	90	146	394
263:15:23:43	0	1	170	244	242	1059	87	92	146	394
263:15:24:43	0	1	169	244	243	1060	85	90	146	394
263:15:25:43	0	1	168	245	243	1063	86	91	146	394
263:15:26:43	0	1	168	244	242	1060	87	92	147	394
263:15:27:42	0	1	169	244	243	1067	85	92	147	394
263:15:28:42	0	1	171	245	242	1056	87	91	146	394
263:15:29:43	0	1	171	244	243	1058	87	91	147	394
263:15:30:42	0	1	171	245	243	1055	87	90	147	393
263:15:31:43	0	1	171	245	243	1062	87	91	147	394
263:15:32:42	0	1	171	245	243	1054	87	89	147	394
263:15:33:43	0	1	171	245	243	1066	87	92	147	394
263:15:34:44	0	1	171	244	243	1068	87	89	146	394
263:15:35:43	0	1	171	244	243	1098	88	91	146	394
263:15:36:43	0	1	170	244	243	1141	87	90	146	394
263:15:37:43	0	1	167	245	243	1179	86	91	146	394
263:15:38:43	0	1	163	244	242	1162	87	91	146	394
263:15:39:42	0	1	162	244	242	1144	86	91	146	394
263:15:40:43	0	1	161	244	243	1142	87	91	146	394
263:15:41:42	0	1	162	245	243	1150	86	92	146	394
263:15:42:42	0	1	170	245	243	1106	88	91	146	394

C50

DAY 263 1984 DATA.7:00-17:00

TIME DAY:HR:MI:SE	CT482 MHO/CM	PHT480 PERCENT	TE581 DEC F	PT481 PSI	PT482 PSI	PT483 PSI	PT484 PSI	FT481 KLB/HR	FT482 KLB/HR	TE481 DEC F
263:15:43:42	0	1	174	244	242	1110	87	91	147	394
263:15:44:43	0	1	176	244	242	1109	87	91	147	394
263:15:45:42	0	1	174	249	247	1096	87	91	146	394
263:15:46:44	0	1	171	251	249	1096	86	91	146	395
263:15:47:43	0	1	167	258	256	1095	88	94	145	395
263:15:48:43	0	1	164	254	252	1091	87	93	145	396
263:15:49:42	0	1	162	254	252	1097	85	94	145	396
263:15:50:42	0	1	160	249	247	1076	82	94	145	396
263:15:51:43	0	1	157	248	246	1061	86	93	145	395
263:15:52:42	0	1	155	247	245	1073	85	93	146	395
263:15:53:42	0	1	153	250	240	1074	85	94	146	395
263:15:54:42	0	1	151	253	251	1092	85	95	145	395
263:15:55:43	0	1	149	255	253	1085	85	94	145	396
263:15:56:43	0	1	148	254	252	1080	85	94	144	397
263:15:57:42	0	1	147	253	250	1074	86	94	144	396
263:15:58:43	0	1	146	249	247	1061	86	93	145	396
263:15:59:42	0	1	146	248	246	1061	86	93	145	396
263:16: 0:42	0	1	145	246	244	1046	86	94	145	395
263:16: 1:42	0	1	144	249	247	1032	85	94	146	395
263:16: 2:42	0	1	143	250	240	1012	85	93	146	395
263:16: 3:43	0	1	142	251	249	998	85	94	146	395
263:16: 4:42	0	1	141	251	249	980	86	93	146	395
263:16: 5:43	0	1	141	248	247	976	85	93	146	396
263:16: 6:43	0	1	141	246	244	967	85	94	146	395
263:16: 7:42	0	1	140	243	241	959	85	94	146	394
263:16: 8:42	0	1	139	241	239	953	86	93	146	393
263:16: 9:43	0	1	138	238	236	951	87	93	146	393
263:16:10:42	0	1	137	236	234	950	85	94	146	392
263:16:11:43	0	1	136	234	232	951	86	94	146	391
263:16:12:43	0	1	135	233	231	954	84	94	146	391
263:16:13:42	0	1	134	231	229	1023	85	94	146	390
263:16:14:42	0	1	133	231	228	1062	85	93	146	389
263:16:15:42	0	1	132	229	227	1060	85	93	146	389
263:16:16:42	0	1	132	225	224	1058	85	93	146	388
263:16:17:43	0	1	131	226	225	1016	84	94	146	387
263:16:18:43	0	1	130	227	225	978	85	94	146	387
263:16:19:42	0	1	129	227	225	938	86	93	146	387
263:16:20:43	0	1	128	228	226	903	85	95	146	387
263:16:21:44	0	1	128	228	226	873	85	93	146	387
263:16:22:43	0	1	127	228	226	855	85	95	146	387
263:16:23:43	0	1	126	226	224	847	85	94	146	387
263:16:24:42	0	1	126	222	221	868	85	95	146	386
263:16:25:44	0	1	125	220	218	845	85	96	146	386
263:16:26:44	0	1	125	218	216	854	86	96	146	385
263:16:27:43	0	1	124	214	213	870	85	96	146	384
263:16:28:44	0	1	124	210	208	904	85	87	146	383
263:16:29:43	0	1	123	206	205	940	85	92	146	381
263:16:30:44	0	1	123	204	202	961	85	92	146	380
263:16:31:43	0	1	122	200	198	947	85	80	147	378
263:16:32:43	0	1	122	200	188	837	85	0	0	377
263:16:33:43	0	1	121	200	188	803	85	0	1	377
263:16:34:43	0	1	121	199	187	776	85	0	1	376
263:16:35:43	0	1	120	199	187	753	85	0	1	376
263:16:36:43	0	1	120	198	186	732	85	0	1	375
263:16:37:42	0	1	120	198	186	712	86	0	1	375
263:16:38:42	0	1	119	198	185	695	85	0	1	375

CS1

TIME DAY:HR:MI:SE	TE482 DEC F	TE483 DEC F	TE484 DEC F	TE486 DEC F	PT501 PSI	PT502 .1 INHG	PT531 PSI	PT581 PSI	PT582 PSI	PT583 PSI
263:11:59:43	342	770	78	83	23	80	128	994	0	0
263:12: 0:43	343	775	78	83	23	80	132	993	0	0
263:12: 1:43	351	780	77	83	22	77	106	995	0	0
263:12: 2:43	357	784	77	84	23	90	109	992	0	0
263:12: 3:43	361	787	77	83	22	81	127	991	0	0
263:12: 4:43	364	789	76	83	22	81	129	993	0	0
263:12: 5:44	368	792	76	84	20	81	99	993	0	0
263:12: 6:43	372	793	77	84	22	88	127	990	0	0
263:12: 7:43	374	795	76	84	21	85	129	991	1	0
263:12: 8:43	378	797	76	84	21	86	130	992	1	0
263:12: 9:43	382	798	76	85	21	85	134	993	1	0
263:12:10:43	384	799	75	85	17	83	96	990	3	0
263:12:11:43	384	800	75	85	18	61	104	317	2	0
263:12:12:43	378	801	75	85	20	85	122	0	0	0
263:12:13:43	376	803	75	86	19	120	119	984	10	0
263:12:14:43	378	804	73	87	13	86	74	993	8	0
263:12:15:43	381	804	71	88	18	61	104	1004	10	0
263:12:16:44	382	805	70	89	18	68	104	1000	10	0
263:12:17:43	383	804	68	90	18	45	104	999	23	0
263:12:18:43	385	804	67	91	17	41	103	996	22	0
263:12:19:43	384	805	66	92	18	40	104	951	21	0
263:12:20:44	378	807	65	93	17	35	103	1076	25	0
263:12:21:43	378	810	64	94	17	30	103	1091	26	0
263:12:22:43	378	811	63	95	17	29	103	1068	25	0
263:12:23:43	378	811	62	96	17	29	102	1062	25	0
263:12:24:43	376	814	62	96	16	29	102	1053	24	0
263:12:25:43	371	815	61	97	16	28	102	1051	24	0
263:12:26:43	370	818	61	97	16	28	102	1059	17	0
263:12:27:43	369	819	61	97	17	28	102	1048	24	0
263:12:28:43	370	821	61	97	17	28	102	1056	24	0
263:12:29:43	370	823	61	98	18	28	103	1049	24	0
263:12:30:42	369	825	61	98	18	27	103	1043	24	0
263:12:31:43	370	828	61	99	18	27	103	1051	25	0
263:12:32:42	370	830	61	99	18	27	103	1050	24	0
263:12:33:43	370	831	60	99	18	27	103	1049	24	0
263:12:34:43	374	833	60	99	18	27	103	1058	25	0
263:12:35:44	377	833	60	99	18	27	103	1062	25	0
263:12:36:43	378	835	60	99	18	29	103	1059	25	0
263:12:37:43	380	835	60	100	18	30	103	1067	25	0
263:12:38:43	379	836	60	100	18	30	103	1062	25	0
263:12:39:43	378	837	60	100	18	31	103	1061	25	0
263:12:40:43	378	838	60	101	18	31	103	1064	25	0
263:12:41:43	378	838	59	101	18	30	103	1055	25	0
263:12:42:43	379	838	59	101	18	29	103	1055	25	0
263:12:43:44	379	839	59	101	18	28	103	1065	26	0
263:12:44:43	377	841	59	102	18	28	103	1058	25	0
263:12:45:43	378	841	59	102	17	28	103	1056	25	0
263:12:46:43	379	842	59	102	17	28	102	1061	26	0
263:12:47:44	376	843	60	102	16	28	102	1053	25	0
263:12:48:43	374	844	59	102	16	27	101	1057	26	0
263:12:49:43	371	846	60	102	16	25	101	1044	28	0
263:12:50:43	370	847	60	101	16	23	100	1049	27	0
263:12:51:43	370	849	60	102	17	23	100	1043	25	0
263:12:52:43	372	851	61	101	16	24	100	1049	25	0
263:12:53:44	376	852	61	101	16	24	100	1057	25	0
263:12:54:44	377	853	62	101	16	25	99	1053	25	0

C52

DAY 263 1984 DATA.7:00-17:00

TIME DAY:HR:MI:SE	TE482 DEC F	TE483 DEC F	TE484 DEC F	TE486 DEC F	PT501 PSI	PT502 .1 INHG	PT531 PSI	PT581 PSI	PT582 PSI	PT583 PSI
263:12:55:43	378	853	62	101	16	25	100	1062	25	0
263:12:56:43	376	854	62	101	16	25	100	1054	25	0
263:12:57:43	373	856	62	101	19	24	86	1046	25	0
263:12:58:43	375	856	62	101	19	24	86	1056	25	0
263:12:59:43	375	858	60	101	20	31	87	960	65	0
263:13:0:43	373	859	59	101	20	33	87	923	65	0
263:13:1:43	372	861	57	102	19	33	87	888	62	0
263:13:2:44	372	863	56	104	19	34	86	863	60	0
263:13:3:43	372	865	55	104	20	34	87	852	59	0
263:13:4:43	373	866	54	106	20	35	87	871	59	0
263:13:5:44	375	869	53	106	20	37	87	957	65	0
263:13:6:43	378	869	52	107	20	39	87	1057	72	0
263:13:7:43	378	869	51	108	19	39	87	1039	71	0
263:13:8:43	377	868	51	108	20	39	87	1023	75	0
263:13:9:43	378	870	51	108	20	39	87	1029	76	0
263:13:10:43	378	870	51	108	20	39	88	1020	75	0
263:13:11:43	377	871	52	108	20	39	88	1010	78	0
263:13:12:42	377	871	52	107	20	40	88	1006	78	0
263:13:13:43	377	872	52	107	20	40	88	1005	70	0
263:13:14:44	377	872	52	107	21	39	89	1009	79	0
263:13:15:43	377	873	53	107	21	40	90	1006	79	0
263:13:16:43	377	873	52	107	21	40	90	1008	80	0
263:13:17:43	377	873	52	107	20	40	90	1007	80	0
263:13:18:43	377	875	53	107	21	40	90	1006	79	0
263:13:19:43	377	875	52	107	21	41	90	1007	80	0
263:13:20:43	377	876	52	108	20	41	89	1005	79	0
263:13:21:43	377	876	52	108	20	42	89	1002	80	0
263:13:22:42	377	876	52	108	20	42	89	1002	79	0
263:13:23:43	377	877	51	108	20	42	89	1007	80	0
263:13:24:43	377	876	52	108	20	42	89	1006	80	0
263:13:25:43	377	877	53	108	20	42	89	1006	80	0
263:13:26:43	377	877	53	109	20	42	89	1005	81	0
263:13:27:43	377	878	53	108	20	42	89	999	81	0
263:13:28:43	377	877	54	108	20	42	89	1000	81	0
263:13:29:43	377	878	54	107	20	45	89	1001	82	0
263:13:30:43	376	878	54	100	21	48	89	997	81	0
263:13:31:43	377	879	53	108	21	48	90	1001	82	0
263:13:32:43	377	879	53	108	21	49	90	1000	82	0
263:13:33:42	378	879	54	108	21	53	91	1008	83	0
263:13:34:43	375	879	54	108	21	55	91	989	81	0
263:13:35:42	377	879	55	107	21	61	91	1004	82	0
263:13:36:43	377	880	55	108	21	56	91	999	82	0
263:13:37:44	383	880	53	107	22	52	92	1012	83	0
263:13:38:43	386	878	55	107	21	48	91	1027	85	0
263:13:39:43	384	874	56	107	21	47	91	1022	84	0
263:13:40:42	376	875	56	107	21	47	90	981	81	0
263:13:41:43	372	878	56	107	21	46	90	917	75	0
263:13:42:42	373	880	56	107	21	46	90	945	78	0
263:13:43:43	374	881	56	107	21	47	90	974	81	0
263:13:44:42	375	881	55	107	21	47	90	981	81	0
263:13:45:43	374	883	55	108	21	47	90	976	81	0
263:13:46:43	374	883	55	108	21	47	90	974	81	0
263:13:47:43	375	883	55	108	21	47	90	982	81	0
263:13:48:42	375	885	55	109	21	47	91	1000	83	0
263:13:49:43	375	884	55	109	21	47	91	1009	84	0
263:13:50:42	375	885	55	109	21	47	90	1016	85	0

C53

TIME DAY:HR:MI:SE	TE482 DEC F	TE483 DEC F	TE484 DEC F	TE486 DEC F	PT501 PSI	PT502 .1 INHG	PT531 PSI	PT501 PSI	PT502 PSI	PT503 PSI
263:13:51:43	375	885	55	109	21	47	90	1009	84	0
263:13:52:42	376	885	55	109	21	47	90	997	84	0
263:13:53:43	376	885	54	109	21	47	90	992	87	0
263:13:54:42	376	885	54	109	21	48	90	904	90	0
263:13:55:43	376	887	55	109	21	48	90	977	92	0
263:13:56:43	376	887	54	109	21	49	90	963	93	0
263:13:57:43	376	887	55	109	21	49	90	958	92	0
263:13:58:44	376	888	54	109	21	49	90	953	92	0
263:13:59:43	376	888	54	110	21	49	90	953	92	0
263:14:0:43	377	888	53	110	21	50	90	953	93	0
263:14:1:43	377	889	54	110	21	51	90	936	95	0
263:14:2:43	376	889	53	111	21	52	90	928	94	0
263:14:3:43	376	889	53	110	21	52	90	927	94	0
263:14:4:42	376	890	53	110	21	52	90	925	95	0
263:14:5:43	377	889	54	110	21	51	90	928	95	0
263:14:6:42	377	890	54	110	21	51	90	924	94	0
263:14:7:43	377	891	55	110	21	51	90	930	93	0
263:14:8:42	377	891	55	110	21	51	90	927	95	0
263:14:9:43	377	891	55	110	21	51	90	927	95	0
263:14:10:42	377	892	55	110	21	51	90	923	94	0
263:14:11:43	377	892	55	110	21	51	90	924	95	0
263:14:12:43	377	892	55	109	21	51	90	929	94	0
263:14:13:42	376	894	55	109	21	51	91	928	96	0
263:14:14:44	377	893	55	110	21	51	90	929	94	0
263:14:15:43	377	894	56	110	21	51	91	930	95	0
263:14:16:43	376	895	55	110	21	51	91	932	95	0
263:14:17:43	376	894	55	110	21	51	90	936	95	0
263:14:18:43	376	895	55	110	21	52	91	932	96	0
263:14:19:43	376	895	55	110	21	53	90	929	96	0
263:14:20:43	376	895	55	110	21	53	90	930	95	0
263:14:21:44	377	895	55	110	21	52	90	938	95	0
263:14:22:43	377	897	55	110	21	52	90	938	97	0
263:14:23:43	377	897	55	110	21	52	91	946	96	0
263:14:24:43	377	898	56	110	21	52	90	944	95	0
263:14:25:43	376	898	54	110	21	52	90	946	94	0
263:14:26:43	376	897	55	110	21	52	90	944	96	0
263:14:27:43	376	898	54	110	21	52	90	945	96	0
263:14:28:43	376	898	54	110	21	53	90	942	96	0
263:14:29:43	376	898	55	110	21	53	90	941	96	0
263:14:30:42	376	899	55	111	21	53	91	944	96	0
263:14:31:43	376	899	55	111	21	53	90	940	97	0
263:14:32:42	376	898	55	111	21	54	90	944	96	0
263:14:33:43	376	899	55	111	21	54	90	941	96	0
263:14:34:42	376	899	54	111	21	54	90	940	96	0
263:14:35:43	376	900	54	112	21	54	90	948	95	0
263:14:36:43	376	900	54	111	21	55	90	923	103	0
263:14:37:42	376	900	54	111	21	55	90	911	101	0
263:14:38:42	376	901	54	112	21	55	90	903	100	0
263:14:39:43	376	901	54	112	21	55	90	678	100	0
263:14:40:42	377	901	54	112	21	56	91	896	99	0
263:14:41:43	377	901	54	112	21	56	91	895	100	0
263:14:42:43	377	901	53	112	21	56	90	898	99	0
263:14:43:43	377	902	55	111	21	56	91	903	100	0
263:14:44:43	377	902	55	112	21	56	90	904	98	0
263:14:45:43	376	902	54	112	21	56	90	903	99	0
263:14:46:43	376	903	53	112	21	57	91	904	100	0

TIME DAY:HR:MI:SE	TE482 DEC F	TE483 DEC F	TE484 DEC F	TE486 DEC F	PT501 PSI	PT502 .1 INHG	PT531 PSI	PT581 PSI	PT582 PSI	PT583 PSI
263:14:47:43	376	903	54	113	21	57	90	903	98	0
263:14:48:43	376	903	53	113	21	57	91	903	100	0
263:14:49:42	377	903	53	113	21	58	91	907	98	0
263:14:50:42	376	904	52	113	21	59	91	905	100	0
263:14:51:43	376	904	53	114	21	59	91	906	99	0
263:14:52:42	376	904	52	114	21	60	91	905	99	0
263:14:53:42	377	904	52	115	21	60	91	905	100	0
263:14:54:42	376	905	52	115	21	60	91	903	99	0
263:14:55:44	376	905	52	115	21	60	91	908	100	0
263:14:56:43	377	904	52	115	21	61	91	912	99	0
263:14:57:43	376	905	51	115	21	61	91	903	101	0
263:14:58:43	377	905	52	115	21	61	91	891	103	0
263:14:59:43	377	905	52	114	21	61	91	880	102	0
263:15:0:42	377	905	52	115	21	62	91	870	105	0
263:15:1:42	377	906	51	114	21	63	91	860	105	0
263:15:2:42	376	905	52	115	21	63	91	851	103	0
263:15:3:43	376	905	52	115	21	63	91	845	102	0
263:15:4:43	377	906	51	115	21	63	91	842	102	0
263:15:5:42	376	906	52	114	21	63	91	838	102	0
263:15:6:42	376	906	51	115	21	63	91	837	101	0
263:15:7:43	376	905	53	114	21	63	91	836	101	0
263:15:8:43	376	906	53	115	21	63	91	838	100	0
263:15:9:43	376	905	52	115	21	63	91	838	100	0
263:15:10:43	376	904	52	115	21	63	91	844	100	0
263:15:11:42	376	904	53	114	21	62	91	851	98	0
263:15:12:42	377	904	52	114	21	60	91	856	100	0
263:15:13:43	377	903	54	114	21	61	91	854	99	0
263:15:14:43	376	902	53	114	21	61	91	851	99	0
263:15:15:43	376	901	54	115	21	61	91	851	99	0
263:15:16:42	376	899	53	115	21	61	91	854	99	0
263:15:17:43	376	898	54	115	21	61	91	854	98	0
263:15:18:43	376	898	53	115	21	61	91	855	98	0
263:15:19:42	376	898	52	114	21	60	91	854	99	0
263:15:20:43	377	895	54	114	21	60	91	853	98	0
263:15:21:42	377	895	56	113	21	60	91	857	99	0
263:15:22:43	377	894	57	113	21	60	91	860	100	0
263:15:23:43	377	893	56	113	21	60	91	863	100	0
263:15:24:43	377	893	56	113	21	60	91	865	101	0
263:15:25:43	377	892	57	112	21	59	91	862	101	0
263:15:26:43	377	892	58	113	21	59	91	866	101	0
263:15:27:42	377	891	56	113	21	61	91	861	100	0
263:15:28:42	377	891	56	113	21	61	91	859	100	0
263:15:29:43	377	891	57	113	21	61	91	855	100	0
263:15:30:42	376	891	56	113	21	61	91	858	100	0
263:15:31:43	377	891	55	113	21	61	91	858	100	0
263:15:32:42	377	891	57	113	21	61	91	863	99	0
263:15:33:43	377	891	56	113	21	61	91	868	98	0
263:15:34:44	377	891	55	113	21	61	91	885	96	0
263:15:35:43	377	891	56	114	21	58	91	930	87	0
263:15:36:43	377	892	56	113	21	54	91	993	85	0
263:15:37:43	377	892	59	113	21	53	92	1031	87	0
263:15:38:43	377	892	58	112	21	53	92	1021	86	0
263:15:39:42	377	891	59	112	21	52	92	1011	80	0
263:15:40:43	377	892	60	112	21	50	92	1021	75	0
263:15:41:42	378	891	59	112	21	35	93	1089	27	0
263:15:42:42	379	892	65	111	21	31	92	1061	26	0

C-85

DAY 263 1984 DATA.7:00-17:00

TIME DAY:HR:MI:SE	TE482 DEC F	TE483 DEC F	TE484 DEC F	TE486 DEC F	PT501 PSI	PT502 .1 INHC	PT531 PSI	PT581 PSI	PT582 PSI	PT583 PSI
263:15:43:42	379	891	64	110	21	28	92	1069	27	0
263:15:44:43	378	890	67	109	21	35	92	1083	10	0
263:15:45:42	376	890	71	107	22	62	106	0	0	0
263:15:46:44	374	889	76	106	16	79	70	0	0	0
263:15:47:43	375	889	78	104	12	84	55	0	0	0
263:15:48:43	378	888	81	102	10	86	46	0	0	0
263:15:49:42	376	887	82	100	10	86	47	0	0	0
263:15:50:42	377	887	83	100	11	87	48	0	0	0
263:15:51:43	381	885	85	99	12	108	50	0	0	0
263:15:52:42	385	881	83	98	12	111	51	0	0	0
263:15:53:42	387	879	84	98	12	112	52	0	0	0
263:15:54:42	387	878	86	97	13	112	53	0	0	0
263:15:55:43	385	878	85	96	13	112	54	0	0	0
263:15:56:43	381	877	87	95	14	112	55	0	0	0
263:15:57:42	381	876	86	95	14	112	56	0	0	0
263:15:58:43	382	874	86	95	14	112	57	0	0	0
263:15:59:42	385	872	87	95	15	112	58	0	0	0
263:16: 0:42	387	870	87	95	15	112	59	0	0	0
263:16: 1:42	388	866	86	94	15	112	60	0	0	0
263:16: 2:42	389	863	88	94	16	112	61	0	0	0
263:16: 3:43	390	860	88	93	14	112	59	0	0	0
263:16: 4:42	390	857	88	92	0	112	14	0	0	0
263:16: 5:43	391	855	89	92	0	164	1	0	0	0
263:16: 6:43	391	853	90	92	0	223	1	0	3	0
263:16: 7:42	390	852	91	91	0	238	1	0	3	0
263:16: 8:42	389	849	89	90	0	239	1	0	3	0
263:16: 9:43	389	848	91	90	0	239	1	0	3	0
263:16:10:42	387	846	91	90	0	239	1	0	3	0
263:16:11:43	387	845	91	89	0	239	1	0	3	0
263:16:12:43	386	844	91	89	0	239	1	0	3	0
263:16:13:42	385	841	91	88	0	239	1	0	3	0
263:16:14:42	385	839	91	88	0	239	1	0	3	0
263:16:15:42	384	838	92	88	0	239	1	0	3	0
263:16:16:42	384	836	91	88	0	239	1	0	3	0
263:16:17:43	383	833	90	88	0	239	1	0	3	0
263:16:18:43	382	829	91	88	0	239	1	0	3	0
263:16:19:42	382	826	91	88	0	239	1	0	3	0
263:16:20:43	382	823	90	87	0	239	1	0	3	0
263:16:21:44	383	821	91	87	0	239	1	0	3	0
263:16:22:43	383	819	91	87	0	239	1	0	3	0
263:16:23:43	383	817	90	87	0	239	1	0	3	0
263:16:24:42	382	813	91	87	0	239	1	0	3	0
263:16:25:44	382	810	91	87	0	239	1	0	3	0
263:16:26:44	381	806	90	87	0	239	1	0	3	0
263:16:27:43	380	800	91	86	0	239	1	0	3	0
263:16:28:44	378	796	90	86	0	239	1	0	3	0
263:16:29:43	377	792	90	87	0	239	1	0	3	0
263:16:30:44	375	788	90	87	0	239	0	0	3	0
263:16:31:43	373	786	90	87	0	239	0	0	3	0
263:16:32:43	374	782	90	87	0	239	0	0	3	0
263:16:33:43	374	780	89	87	0	239	0	0	3	0
263:16:34:43	375	778	89	87	0	239	0	0	3	0
263:16:35:43	374	774	89	87	0	239	0	0	3	0
263:16:36:43	374	773	89	87	0	239	0	0	3	0
263:16:37:42	374	770	89	87	0	239	0	0	3	0
263:16:38:42	374	769	89	87	0	239	0	0	3	0

C-56



TIME DAY:HR:MI:SE	LT511 INCH	TT501 DEC F	TT502 DEC F	TT507 DEC F	TT510 DEC F	TT511 DEC F	TT512 DEC F	TT513 DEC F	TT514 DEC F	TT515 DEC F
263:11:59:43	7	96	96	91	103	101	98	99	101	100
263:12:0:43	7	99	99	92	102	100	98	99	100	100
263:12:1:43	9	99	100	93	102	100	97	98	100	100
263:12:2:43	9	100	100	93	102	99	97	98	100	99
263:12:3:43	10	101	101	94	101	99	97	97	99	99
263:12:4:43	11	103	103	95	101	99	96	97	99	99
263:12:5:44	11	102	104	96	101	99	96	96	99	99
263:12:6:43	9	104	105	96	100	98	96	96	98	98
263:12:7:43	12	106	107	97	100	98	95	96	98	98
263:12:8:43	8	109	110	98	100	97	95	96	98	98
263:12:9:43	12	112	113	98	99	97	95	95	97	97
263:12:10:43	13	115	116	94	99	97	94	95	97	97
263:12:11:43	14	119	120	94	100	97	95	96	98	98
263:12:12:43	14	115	119	100	100	97	95	96	98	98
263:12:13:43	13	115	117	104	99	97	95	95	97	97
263:12:14:43	13	119	119	104	99	97	95	96	97	97
263:12:15:43	14	123	125	99	100	98	95	96	98	98
263:12:16:44	14	126	129	95	102	99	97	98	100	100
263:12:17:43	15	127	131	95	103	101	99	100	102	101
263:12:18:43	15	129	134	95	105	103	101	102	104	103
263:12:19:43	14	128	135	97	106	104	102	104	106	104
263:12:20:44	12	128	134	102	107	106	104	106	107	106
263:12:21:43	12	132	137	100	109	107	105	107	109	107
263:12:22:43	11	134	139	99	110	108	107	109	110	108
263:12:23:43	10	136	141	101	111	109	108	110	112	110
263:12:24:43	10	137	143	102	113	110	109	111	113	111
263:12:25:43	11	139	145	104	114	111	110	112	114	112
263:12:26:43	11	141	146	105	115	113	111	114	115	113
263:12:27:43	10	129	142	113	115	114	112	115	116	114
263:12:28:43	10	127	140	114	117	115	113	116	117	115
263:12:29:43	9	125	139	114	117	115	114	117	118	116
263:12:30:42	8	124	138	113	118	116	115	118	119	117
263:12:31:43	9	123	137	111	119	117	116	119	120	118
263:12:32:42	9	123	137	110	120	118	117	120	121	119
263:12:33:43	10	122	136	110	121	119	118	121	122	120
263:12:34:43	11	122	136	108	122	120	119	122	123	120
263:12:35:44	11	122	136	108	123	121	120	123	124	121
263:12:36:43	12	122	136	107	124	122	121	124	125	122
263:12:37:43	14	122	135	108	125	123	122	124	126	123
263:12:38:43	14	121	135	108	125	123	122	125	127	124
263:12:39:43	15	121	135	107	126	124	123	126	128	125
263:12:40:43	15	121	135	107	127	125	124	127	128	125
263:12:41:43	14	121	135	107	128	126	125	128	129	126
263:12:42:43	13	121	135	107	128	126	125	128	130	127
263:12:43:44	12	121	134	107	129	127	126	129	130	127
263:12:44:43	11	124	135	106	130	128	127	130	131	128
263:12:45:43	12	130	139	104	130	128	127	130	132	129
263:12:46:43	12	133	141	103	131	129	128	131	133	129
263:12:47:44	12	136	143	103	131	129	129	132	133	130
263:12:48:43	12	138	145	104	132	130	129	132	134	131
263:12:49:43	11	141	147	104	132	131	130	133	134	131
263:12:50:43	11	143	149	105	133	131	130	133	135	132
263:12:51:43	11	136	147	111	134	132	131	134	135	132
263:12:52:43	11	138	148	112	134	132	131	134	136	132
263:12:53:44	11	140	149	111	134	132	132	135	136	133
263:12:54:44	11	141	150	111	135	133	132	135	137	133

C57

DAY 263 1984 DATA.7:00-17:00

TIME DAY:HR:MI:SE	LT511 INCH	TT501 DEC F	TT502 DEC F	TT507 DEC F	TT510 DEC F	TT511 DEC F	TT512 DEC F	TT513 DEC F	TT514 DEC F	TT515 DEC F
263:12:55:43	11	141	150	111	135	133	133	136	137	134
263:12:56:43	11	138	149	114	136	134	133	136	138	134
263:12:57:43	11	140	150	115	136	134	134	137	138	135
263:12:58:43	11	142	151	114	137	135	134	137	138	135
263:12:59:43	10	141	151	116	139	137	136	139	141	137
263:13:0:43	10	143	150	116	140	138	137	141	142	139
263:13:1:43	10	147	151	116	141	139	138	142	143	140
263:13:2:44	10	149	152	116	142	140	139	142	144	141
263:13:3:43	10	148	152	116	143	141	140	143	145	142
263:13:4:43	10	148	152	118	143	141	140	144	145	142
263:13:5:44	10	148	151	118	144	141	141	144	146	143
263:13:6:43	10	149	152	118	145	142	142	145	147	144
263:13:7:43	10	150	152	119	146	143	143	146	148	145
263:13:8:43	10	151	153	118	147	144	144	147	149	146
263:13:9:43	10	151	153	119	148	145	145	148	150	147
263:13:10:43	10	151	153	121	148	146	145	149	150	148
263:13:11:43	10	151	153	121	149	147	146	150	151	148
263:13:12:42	10	151	153	122	150	148	147	150	152	149
263:13:13:43	10	148	152	123	151	148	148	151	153	150
263:13:14:44	10	146	150	123	151	149	148	152	154	151
263:13:15:43	10	145	149	122	152	150	149	153	154	151
263:13:16:43	10	146	149	121	153	151	150	153	155	152
263:13:17:43	10	147	149	120	154	151	151	154	156	153
263:13:18:43	10	148	150	119	154	152	151	155	156	154
263:13:19:43	10	149	150	119	155	152	152	155	157	154
263:13:20:43	10	150	151	119	155	153	152	156	158	155
263:13:21:43	10	151	152	120	156	153	153	156	158	155
263:13:22:42	10	152	152	120	156	154	153	157	159	156
263:13:23:43	10	153	153	121	157	154	154	157	159	156
263:13:24:43	10	152	153	122	157	155	154	158	160	157
263:13:25:43	10	152	153	123	158	155	155	158	160	157
263:13:26:43	10	152	153	122	158	156	155	159	161	158
263:13:27:43	11	152	153	122	159	156	156	159	161	158
263:13:28:43	11	152	153	122	159	157	156	159	161	159
263:13:29:43	11	152	153	122	160	157	156	160	162	159
263:13:30:43	12	151	153	122	160	157	157	160	162	159
263:13:31:43	13	149	151	122	160	158	157	161	162	160
263:13:32:43	14	148	150	121	161	158	158	161	163	160
263:13:33:42	14	147	150	121	161	158	158	161	163	160
263:13:34:43	15	146	149	120	161	159	158	161	164	161
263:13:35:42	16	145	148	120	162	159	158	162	164	161
263:13:36:43	15	145	147	118	162	159	159	162	164	161
263:13:37:44	13	145	147	118	162	160	159	163	165	162
263:13:38:43	12	145	147	118	163	160	160	163	165	162
263:13:39:43	11	144	147	117	164	161	160	164	166	163
263:13:40:42	11	144	146	117	164	161	161	164	166	164
263:13:41:43	12	144	146	116	164	161	161	164	166	164
263:13:42:42	12	144	146	116	164	161	161	164	166	164
263:13:43:43	11	144	146	116	164	162	161	165	167	164
263:13:44:42	11	144	146	115	165	162	162	165	167	164
263:13:45:43	11	144	146	115	165	162	162	165	167	164
263:13:46:43	11	144	146	115	166	163	162	166	168	165
263:13:47:43	11	144	146	115	166	163	163	166	168	165
263:13:48:42	11	144	146	114	166	164	163	166	168	166
263:13:49:43	11	145	146	114	167	164	164	167	169	166
263:13:50:42	10	145	146	115	167	164	164	167	169	166

C58

## DAY 263 1984 DATA.7:00-17:00

TIME DAY:HR:MI:SE	LT511 INCH	TT501 DEC F	TT502 DEC F	TT507 DEC F	TT510 DEC F	TT511 DEC F	TT512 DEC F	TT513 DEC F	TT514 DEC F	TT515 DEC F
263:13:51:43	10	145	146	114	168	165	164	168	170	167
263:13:52:42	10	145	146	114	168	165	165	168	170	167
263:13:53:43	10	145	146	114	168	166	165	168	170	168
263:13:54:42	10	146	146	114	169	166	166	169	171	168
263:13:55:43	10	146	146	114	169	167	166	169	171	169
263:13:56:43	10	145	146	113	169	167	167	170	172	169
263:13:57:43	10	145	146	114	170	167	167	170	172	170
263:13:58:44	10	145	146	114	171	168	167	171	173	170
263:13:59:43	10	145	146	113	171	168	168	171	173	170
263:14:0:43	10	145	146	113	171	169	168	171	173	171
263:14:1:43	10	145	146	113	172	169	168	171	174	171
263:14:2:43	10	146	146	113	172	169	169	172	174	172
263:14:3:43	10	146	146	113	172	170	169	172	174	172
263:14:4:42	10	145	146	113	173	170	169	172	175	172
263:14:5:43	10	146	146	113	173	170	170	173	175	173
263:14:6:42	10	146	146	113	173	171	170	173	175	173
263:14:7:43	10	145	146	113	174	171	170	173	175	173
263:14:8:42	10	145	146	113	174	171	171	174	176	173
263:14:9:43	10	145	146	113	174	171	171	174	176	174
263:14:10:42	10	145	146	113	174	171	171	174	176	174
263:14:11:43	10	146	146	113	175	172	171	174	177	174
263:14:12:43	10	146	146	113	175	172	172	175	177	175
263:14:13:42	10	146	146	113	175	172	172	175	177	175
263:14:14:44	10	146	146	113	175	172	172	175	177	175
263:14:15:43	10	146	146	113	176	173	172	175	177	175
263:14:16:43	10	145	146	113	176	173	172	175	178	175
263:14:17:43	10	146	146	113	176	173	172	175	178	176
263:14:18:43	10	145	146	112	176	173	173	176	178	176
263:14:19:43	10	146	146	112	176	173	173	176	178	176
263:14:20:43	10	146	146	112	177	174	173	176	178	176
263:14:21:44	10	146	146	113	177	174	173	176	178	176
263:14:22:43	10	146	146	113	177	174	173	176	179	176
263:14:23:43	10	146	146	113	177	174	174	176	179	177
263:14:24:43	10	146	146	112	177	174	174	177	179	177
263:14:25:43	10	146	146	113	177	174	174	177	179	177
263:14:26:43	10	146	146	113	178	175	174	177	180	177
263:14:27:43	10	146	146	113	178	175	174	177	180	177
263:14:28:43	10	146	146	113	178	175	175	178	180	178
263:14:29:43	10	146	146	113	178	175	175	178	180	178
263:14:30:42	10	146	146	113	178	175	175	178	180	178
263:14:31:43	10	146	146	113	179	175	175	178	181	178
263:14:32:42	10	146	146	113	179	176	175	178	181	178
263:14:33:43	10	146	146	113	179	176	175	178	181	179
263:14:34:42	10	146	146	113	179	176	176	179	181	179
263:14:35:43	10	146	146	112	179	176	176	179	181	179
263:14:36:43	10	146	146	113	180	177	176	179	182	179
263:14:37:42	10	146	146	113	180	177	177	180	182	180
263:14:38:42	10	146	146	112	181	177	177	180	183	180
263:14:39:43	10	146	146	112	181	178	177	180	183	180
263:14:40:42	10	146	145	112	181	178	177	180	183	181
263:14:41:43	10	146	146	112	181	178	178	180	183	181
263:14:42:43	10	146	146	112	181	178	178	180	183	181
263:14:43:43	10	146	146	112	181	178	178	181	183	181
263:14:44:43	10	146	146	112	182	178	178	181	183	181
263:14:45:43	10	146	146	112	182	178	178	181	184	181
263:14:46:43	10	146	146	112	182	179	178	181	184	181

C59

DAY 263 1984 DATA.7:00-17:00

TIME DAY:HR:MI:SE	LT511 INCH	TT501 DEC F	TT502 DEC F	TT507 DEC F	TT510 DEC F	TT511 DEC F	TT512 DEC F	TT513 DEC F	TT514 DEC F	TT515 DEC F
263:14:47:43	10	146	146	112	182	179	178	181	184	182
263:14:48:43	10	146	146	112	182	179	178	181	184	182
263:14:49:42	10	146	146	112	182	179	179	181	184	182
263:14:50:42	10	146	146	112	182	179	179	181	184	182
263:14:51:43	10	146	145	112	182	179	179	182	184	182
263:14:52:42	10	146	145	112	182	179	179	182	184	182
263:14:53:42	10	146	146	112	183	179	179	182	185	182
263:14:54:42	10	146	146	111	183	180	179	182	185	182
263:14:55:44	10	146	146	112	183	180	179	182	185	182
263:14:56:43	10	146	146	112	183	180	180	182	185	183
263:14:57:43	10	146	146	111	183	180	180	182	185	183
263:14:58:43	10	146	146	111	184	180	180	183	185	183
263:14:59:43	10	146	145	111	184	181	180	183	186	183
263:15:0:42	10	146	145	111	184	181	181	183	186	184
263:15:1:42	10	146	146	111	185	181	181	184	186	184
263:15:2:42	10	146	146	111	185	181	181	184	187	184
263:15:3:43	11	146	146	111	185	182	181	184	187	184
263:15:4:43	11	146	146	111	185	182	181	184	187	185
263:15:5:42	11	146	146	111	185	182	181	184	187	185
263:15:6:42	10	146	145	111	185	182	181	184	187	185
263:15:7:43	11	146	145	111	185	182	181	184	187	185
263:15:8:43	11	146	145	111	185	182	182	184	187	185
263:15:9:43	11	146	146	111	185	182	182	184	187	185
263:15:10:43	11	146	145	111	185	182	182	184	187	185
263:15:11:42	10	146	146	111	185	182	182	184	187	185
263:15:12:42	10	146	145	111	185	182	182	184	187	185
263:15:13:43	10	146	145	111	185	182	182	184	187	185
263:15:14:43	11	146	145	111	185	182	182	184	187	185
263:15:15:43	10	146	145	111	185	182	182	184	187	185
263:15:16:42	10	146	145	111	185	182	182	184	187	185
263:15:17:43	10	146	145	111	185	182	182	184	187	185
263:15:18:43	10	146	145	111	185	182	182	184	187	185
263:15:19:42	10	146	145	111	186	182	182	184	187	185
263:15:20:43	11	146	145	111	186	182	182	184	187	185
263:15:21:42	10	146	145	111	186	182	182	185	187	185
263:15:22:43	10	146	145	111	186	182	182	185	187	185
263:15:23:43	10	146	145	111	186	183	182	185	188	186
263:15:24:43	11	146	145	111	186	183	182	185	188	186
263:15:25:43	11	146	145	111	186	183	183	185	188	186
263:15:26:43	10	146	145	111	186	183	183	185	188	186
263:15:27:42	11	146	145	111	186	183	183	185	188	186
263:15:28:42	11	146	145	111	186	183	183	185	188	186
263:15:29:43	11	146	145	111	186	183	183	185	188	186
263:15:30:42	11	146	145	111	186	183	183	185	188	186
263:15:31:43	11	146	145	111	186	183	183	185	188	186
263:15:32:42	11	146	145	111	187	183	183	185	188	186
263:15:33:43	11	146	145	111	186	183	183	185	188	186
263:15:34:44	11	146	145	111	186	183	183	185	188	186
263:15:35:43	11	146	145	111	186	182	182	185	187	185
263:15:36:43	11	145	145	111	185	182	182	184	187	185
263:15:37:43	11	146	145	111	185	182	181	184	186	184
263:15:38:43	11	146	145	110	185	182	181	184	186	184
263:15:39:42	11	145	145	110	184	181	181	183	186	184
263:15:40:43	11	145	145	110	184	180	180	183	185	183
263:15:41:42	12	144	145	111	183	180	179	182	184	182
263:15:42:42	12	140	145	110	180	177	177	179	182	179

C60

TIME DAY:HR:MI:SE	LT511 INCH	TT501 DEC F	TT502 DEC F	TT507 DEC F	TT510 DEC F	TT511 DEC F	TT512 DEC F	TT513 DEC F	TT514 DEC F	TT515 DEC F
263:15:43:42	11	138	144	110	179	176	176	178	180	178
263:15:44:43	11	136	143	110	178	175	175	177	179	176
263:15:45:42	11	129	136	113	176	173	174	176	178	175
263:15:46:44	10	127	133	115	175	172	172	174	176	173
263:15:47:43	9	123	130	115	173	171	171	172	174	172
263:15:48:43	9	118	129	114	172	170	170	171	173	171
263:15:49:42	9	116	131	112	172	169	170	170	173	171
263:15:50:42	9	110	132	111	172	169	170	170	172	171
263:15:51:43	10	107	132	109	172	169	170	170	172	170
263:15:52:42	11	106	133	107	171	169	169	170	172	170
263:15:53:42	11	104	133	107	171	169	169	170	172	170
263:15:54:42	12	102	134	106	171	169	169	170	171	170
263:15:55:43	13	100	134	105	170	169	169	169	171	169
263:15:56:43	14	99	134	105	170	169	169	169	171	169
263:15:57:42	13	98	134	104	170	168	169	169	171	169
263:15:58:43	13	96	134	104	170	168	168	169	170	169
263:15:59:42	13	95	134	103	169	168	168	168	170	168
263:16:0:42	13	94	134	102	169	168	168	168	170	168
263:16:1:42	13	93	134	102	169	167	168	168	169	168
263:16:2:42	13	92	134	101	168	167	167	168	169	167
263:16:3:43	13	98	134	101	168	167	167	167	169	167
263:16:4:42	13	101	134	102	168	166	167	167	168	167
263:16:5:43	14	127	134	103	167	166	167	167	168	166
263:16:6:43	14	131	134	103	167	166	166	167	168	166
263:16:7:42	14	132	133	103	167	166	166	166	168	166
263:16:8:42	14	133	133	102	166	165	166	166	167	165
263:16:9:43	14	134	133	102	166	165	166	166	167	165
263:16:10:42	14	135	133	102	166	165	166	166	167	165
263:16:11:43	14	135	133	102	166	164	165	165	166	164
263:16:12:43	14	135	133	102	165	164	165	165	166	164
263:16:13:42	14	135	133	102	165	164	165	165	166	164
263:16:14:42	14	136	133	102	165	164	165	164	166	164
263:16:15:42	14	136	133	101	164	164	164	164	165	163
263:16:16:42	14	136	133	101	164	163	164	164	165	163
263:16:17:43	14	136	133	101	164	163	164	164	165	163
263:16:18:43	14	136	133	101	163	163	164	164	164	162
263:16:19:42	14	136	133	101	163	162	163	163	164	162
263:16:20:43	14	136	133	101	163	162	163	163	164	162
263:16:21:44	14	137	133	101	163	162	163	163	164	161
263:16:22:43	14	137	134	100	162	162	163	163	163	161
263:16:23:43	14	137	134	100	162	162	162	162	163	161
263:16:24:42	14	137	134	100	162	161	162	162	163	161
263:16:25:44	14	137	134	100	161	161	162	162	163	161
263:16:26:44	14	137	134	100	161	161	162	162	162	160
263:16:27:43	14	137	135	100	161	161	162	162	162	160
263:16:28:44	14	137	135	100	161	160	161	161	162	160
263:16:29:43	14	137	135	100	161	160	161	161	162	160
263:16:30:44	14	137	136	99	160	160	161	161	162	159
263:16:31:43	14	137	136	99	160	160	161	161	161	159
263:16:32:43	14	137	137	99	160	160	161	161	161	159
263:16:33:43	14	137	137	99	160	159	160	160	161	159
263:16:34:43	14	137	138	99	160	159	160	160	161	158
263:16:35:43	14	137	138	99	159	159	160	160	160	158
263:16:36:43	14	137	139	99	159	159	160	160	160	158
263:16:37:42	14	137	140	99	159	159	159	160	160	158
263:16:38:42	14	137	140	99	159	158	159	159	160	157

C-61

DAY 263 1984 DATA.7:00-17:00

TIME DAY:HR:MI:SE	TT583 DEC F	AZT581 PERCENT	PFT581 .01 LAG	ET581 VAC	IT581 AMPS	JT581 KWATTS	VT581 KVARs	ST581 PERCENT	ST582 RPM	TE503 DEC F
263:11:59:53	611	2	100	1	0	0	0	0	480	88
263:12: 0:53	665	2	100	3	0	0	0	0	601	88
263:12: 1:54	559	1	100	0	0	0	0	0	255	89
263:12: 2:53	653	2	100	0	0	0	0	0	385	90
263:12: 3:53	677	2	100	2	0	0	0	0	522	91
263:12: 4:53	686	3	100	2	0	0	0	0	591	91
263:12: 5:53	625	1	100	0	0	0	0	0	357	92
263:12: 6:52	693	2	100	2	0	0	0	0	553	92
263:12: 7:53	702	3	100	3	0	0	0	0	685	93
263:12: 8:53	708	4	100	4	0	0	0	0	794	94
263:12: 9:54	715	5	100	4	0	0	0	0	891	95
263:12:10:53	722	7	100	406	0	0	0	0	899	104
263:12:11:53	729	18	100	7	0	0	0	0	1042	114
263:12:12:53	698	2	100	2	0	0	0	0	488	120
263:12:13:53	727	3	100	2	0	0	0	0	570	120
263:12:14:53	735	5	100	393	0	0	0	0	900	117
263:12:15:53	747	12	100	454	0	0	0	50	1198	125
263:12:16:53	753	13	100	453	0	0	0	51	1199	128
263:12:17:53	765	12	98	452	92	73	2	50	1197	129
263:12:18:53	773	12	100	453	92	77	15	50	1198	127
263:12:19:53	778	12	100	454	82	68	19	50	1197	126
263:12:20:53	786	13	100	453	124	102	10	50	1197	127
263:12:21:53	790	14	100	453	133	109	18	50	1196	127
263:12:22:53	795	14	100	453	132	109	12	50	1196	127
263:12:23:53	798	15	100	453	131	109	10	50	1196	129
263:12:24:53	802	16	100	453	128	105	9	50	1196	131
263:12:25:53	805	14	100	452	135	110	14	50	1196	134
263:12:26:53	807	13	98	453	134	109	14	50	1196	137
263:12:27:53	809	13	100	452	134	112	12	50	1196	139
263:12:28:53	812	15	100	452	135	112	13	50	1196	138
263:12:29:52	813	14	100	452	133	110	11	50	1196	137
263:12:30:53	816	15	100	453	137	112	8	50	1196	136
263:12:31:53	818	15	100	452	140	113	16	50	1196	135
263:12:32:53	820	16	100	452	139	113	14	50	1196	134
263:12:33:53	822	14	100	452	139	113	19	50	1196	133
263:12:34:53	824	15	100	451	140	115	16	50	1196	132
263:12:35:53	826	14	100	451	145	118	21	50	1196	132
263:12:36:53	827	14	100	451	141	114	14	50	1196	131
263:12:37:53	829	14	100	450	140	116	21	50	1196	131
263:12:38:53	830	15	100	450	138	113	18	50	1196	131
263:12:39:53	831	14	100	451	141	114	12	50	1196	131
263:12:40:53	832	15	100	450	139	114	18	50	1196	131
263:12:41:53	834	17	100	451	142	115	17	50	1196	131
263:12:42:53	834	16	100	450	141	115	20	50	1196	130
263:12:43:53	835	16	99	450	145	117	30	50	1196	130
263:12:44:54	837	16	99	450	150	121	25	50	1196	130
263:12:45:53	837	15	99	450	155	123	34	50	1196	131
263:12:46:53	838	15	99	449	154	119	39	50	1196	132
263:12:47:53	839	16	99	450	155	121	37	50	1196	134
263:12:48:54	840	17	99	450	164	130	34	50	1196	135
263:12:49:53	842	16	100	450	172	139	28	50	1196	137
263:12:50:53	842	17	99	453	168	130	31	50	1196	140
263:12:51:53	844	16	99	453	165	126	31	50	1196	141
263:12:52:53	845	16	100	454	166	134	0	50	1196	141
263:12:53:53	846	16	100	454	156	127	0	50	1196	141
263:12:54:53	847	16	100	454	157	128	2	50	1196	142

CG2

## DAY 263 1984 DATA.7:00-17:00

TIME DAY:HR:MI:SE	TT583 DEC F	AZT581 PERCENT	PFT581 .01 LAG	ET581 VAC	IT581 AMPS	JT581 KWATTS	VT581 KVARs	ST581 PERCENT	ST582 RPM	TE503 DEC F
263:12:55:53	849	16	100	454	153	126	7	50	1196	142
263:12:56:53	849	17	100	454	153	126	8	50	1196	142
263:12:57:53	851	17	100	454	157	127	5	50	1196	142
263:12:58:53	851	16	100	454	221	384	3	50	1196	142
263:12:59:53	857	24	100	457	501	401	23	50	1196	141
263:13:0:54	860	22	100	457	451	364	21	50	1196	141
263:13:1:53	863	22	100	457	431	348	20	50	1196	140
263:13:2:52	866	21	100	456	413	333	25	50	1196	140
263:13:3:53	868	21	100	456	407	326	31	50	1196	140
263:13:4:53	870	21	99	456	396	319	39	50	1196	140
263:13:5:53	873	23	100	456	455	368	32	50	1196	139
263:13:6:53	875	24	100	456	507	410	19	50	1196	140
263:13:7:53	875	24	100	456	489	392	20	50	1196	140
263:13:8:53	877	23	100	456	520	417	22	50	1196	140
263:13:9:54	877	23	100	456	526	424	17	50	1196	140
263:13:10:53	879	23	100	456	522	420	21	50	1196	140
263:13:11:53	879	24	100	456	547	438	24	50	1196	140
263:13:12:53	880	23	100	456	543	435	19	50	1196	140
263:13:13:53	881	25	100	456	547	439	23	50	1196	140
263:13:14:53	881	23	100	456	559	450	19	50	1196	140
263:13:15:53	882	25	100	456	559	449	19	50	1196	139
263:13:16:53	883	24	100	455	566	453	28	50	1196	138
263:13:17:53	883	24	100	455	565	451	30	50	1196	138
263:13:18:52	883	24	100	456	562	448	32	50	1196	138
263:13:19:53	884	24	100	456	566	453	25	50	1196	138
263:13:20:53	885	24	100	456	565	453	27	50	1196	138
263:13:21:53	885	24	100	456	562	447	28	50	1196	138
263:13:22:53	885	25	100	457	558	451	0	50	1196	138
263:13:23:53	886	25	100	458	559	450	8	50	1196	139
263:13:24:53	886	25	100	458	557	449	6	50	1196	139
263:13:25:53	886	24	100	458	563	455	9	50	1196	140
263:13:26:53	886	24	100	458	558	451	11	50	1196	140
263:13:27:53	887	24	100	458	568	458	17	50	1196	140
263:13:28:53	887	24	100	458	569	458	11	50	1196	141
263:13:29:53	887	25	100	458	560	452	13	50	1196	140
263:13:30:53	887	24	100	458	557	452	19	50	1196	141
263:13:31:53	887	23	100	458	553	447	22	50	1196	140
263:13:32:54	888	22	100	457	552	444	25	50	1196	140
263:13:33:53	888	22	100	457	560	449	29	50	1196	139
263:13:34:53	888	22	100	457	539	434	31	50	1196	138
263:13:35:53	889	23	100	457	550	444	24	50	1196	137
263:13:36:53	889	23	100	457	549	443	20	50	1196	137
263:13:37:53	889	25	100	458	567	458	10	50	1196	136
263:13:38:53	889	22	100	458	580	468	12	50	1196	136
263:13:39:53	889	20	100	458	585	471	18	50	1196	135
263:13:40:53	889	22	100	458	553	445	27	50	1196	135
263:13:41:53	889	22	100	457	517	417	26	50	1196	135
263:13:42:54	889	23	100	458	538	435	21	50	1196	134
263:13:43:53	890	22	100	457	557	447	29	50	1196	134
263:13:44:53	891	22	100	458	559	450	20	50	1196	134
263:13:45:53	891	21	100	457	554	446	27	50	1196	133
263:13:46:53	892	22	100	457	555	448	24	50	1196	133
263:13:47:53	892	21	100	457	563	453	26	50	1196	133
263:13:48:53	893	23	100	457	576	462	26	50	1196	133
263:13:49:53	893	22	100	457	585	469	36	50	1196	133
263:13:50:53	893	23	100	457	585	470	29	50	1196	133

C63

DAY 263 1984 DATA.7:00-17:00

TIME DAY:HR:MI:SE	TT583 DEC F	AZT581 PERCENT	PFT581 .01 LAG	ET581 VAC	IT581 AMPS	JT581 KWATTS	VT581 KVAHS	ST581 PERCENT	ST582 RPM	TE503 DEC F
263:13:51:53	894	24	100	457	594	478	32	50	1196	134
263:13:52:53	894	24	100	458	581	466	26	50	1196	134
263:13:53:52	895	25	100	457	597	473	29	50	1196	133
263:13:54:53	895	24	100	457	616	495	28	50	1196	133
263:13:55:54	895	24	100	456	632	507	14	50	1196	133
263:13:56:53	896	23	100	457	630	505	15	50	1196	134
263:13:57:52	896	23	100	456	622	500	20	50	1196	133
263:13:58:53	897	22	100	456	618	498	17	50	1196	133
263:13:59:53	898	22	100	456	624	502	15	50	1196	133
263:14:0:54	898	21	100	457	619	497	10	50	1196	133
263:14:1:53	898	21	100	457	641	516	7	50	1196	133
263:14:2:52	899	22	100	457	634	510	6	50	1195	133
263:14:3:53	899	20	100	457	633	509	5	50	1196	133
263:14:4:53	900	21	100	457	636	510	21	50	1196	133
263:14:5:53	900	21	100	457	636	511	19	50	1196	134
263:14:6:53	900	20	100	457	634	510	20	50	1195	133
263:14:7:52	900	20	100	457	634	509	22	50	1196	134
263:14:8:53	901	21	100	457	640	515	24	50	1196	133
263:14:9:53	902	21	100	457	644	516	23	50	1196	133
263:14:10:52	902	20	100	457	637	511	26	50	1195	133
263:14:11:53	902	20	100	457	644	516	32	50	1196	133
263:14:12:52	903	21	100	457	633	509	30	50	1196	133
263:14:13:53	903	21	100	457	643	517	19	50	1196	133
263:14:14:53	903	20	100	457	641	514	26	50	1196	133
263:14:15:53	904	21	100	457	641	514	23	50	1196	134
263:14:16:52	904	19	100	457	649	521	23	50	1196	133
263:14:17:52	905	22	100	457	641	514	30	50	1195	133
263:14:18:52	905	21	100	457	647	519	30	50	1196	133
263:14:19:52	905	20	100	462	648	519	24	50	1196	133
263:14:20:52	905	21	100	464	641	519	24	50	1196	133
263:14:21:53	906	21	100	465	628	512	24	50	1196	133
263:14:22:53	907	21	100	466	640	524	28	50	1196	133
263:14:23:52	907	20	100	466	638	523	31	50	1196	133
263:14:24:52	907	20	100	466	623	511	34	50	1196	133
263:14:25:53	907	20	100	466	623	509	36	50	1196	133
263:14:26:53	907	23	100	466	633	518	33	50	1195	133
263:14:27:53	908	21	100	466	635	519	38	50	1196	133
263:14:28:53	908	20	100	466	631	518	30	50	1196	133
263:14:29:53	908	20	100	466	628	516	34	50	1196	134
263:14:30:53	909	21	100	466	635	519	39	50	1196	134
263:14:31:53	909	20	100	466	629	514	37	50	1195	133
263:14:32:53	909	20	100	466	630	516	37	50	1196	133
263:14:33:53	910	20	100	466	633	518	43	50	1195	134
263:14:34:53	910	19	100	466	631	516	36	50	1196	134
263:14:35:53	910	19	100	466	627	513	37	50	1196	134
263:14:36:53	910	19	100	466	671	552	24	50	1196	134
263:14:37:53	911	21	100	466	659	540	25	50	1195	134
263:14:38:53	911	21	100	466	660	541	26	50	1196	134
263:14:39:53	911	21	100	466	659	539	24	50	1195	134
263:14:40:53	911	22	100	466	657	538	24	50	1196	134
263:14:41:53	911	21	100	466	650	535	26	50	1195	134
263:14:42:53	912	21	100	466	653	537	24	50	1195	134
263:14:43:54	912	21	100	466	650	532	24	50	1195	134
263:14:44:53	912	22	100	465	647	529	36	50	1196	134
263:14:45:53	912	21	100	466	648	530	29	50	1195	133
263:14:46:53	913	22	100	466	654	534	31	50	1497	134

C64



TIME DAY:HR:MI:SE	TT583 DEC F	AZT581 PERCENT	PFT581 .01 IAC	ET581 VAC	IT581 AMPS	JT581 KWATTS	VT581 KVARs	ST581 PERCENT	ST582 RPM	TE503 DEG F
263:14:47:53	913	21	100	466	648	532	29	50	1195	133
263:14:48:53	913	21	100	466	652	536	23	50	1196	134
263:14:49:52	913	22	100	466	651	532	24	50	1195	134
263:14:50:53	913	21	100	466	649	530	26	50	1195	134
263:14:51:53	913	23	100	466	646	530	21	50	1195	133
263:14:52:52	914	22	100	466	645	527	25	50	1195	133
263:14:53:53	914	22	100	466	642	530	16	50	1195	133
263:14:54:53	914	22	100	466	645	527	20	50	1195	133
263:14:55:53	914	22	100	466	643	526	21	50	1195	133
263:14:56:53	915	22	100	466	648	531	18	50	1196	134
263:14:57:53	915	22	100	466	657	538	21	50	1195	133
263:14:58:53	915	22	100	466	675	553	21	50	1195	133
263:14:59:54	915	23	100	466	670	549	18	50	1195	134
263:15: 0:53	915	23	100	466	688	565	13	50	1195	133
263:15: 1:52	916	22	100	466	679	556	17	50	1196	133
263:15: 2:52	916	23	100	466	666	545	22	50	1196	133
263:15: 3:52	916	23	100	466	665	545	18	50	1195	134
263:15: 4:52	916	23	100	466	671	549	25	50	1195	133
263:15: 5:52	916	24	100	466	658	537	28	50	1196	133
263:15: 6:53	916	24	100	466	661	541	28	50	1195	134
263:15: 7:52	916	24	100	466	662	540	38	50	1195	134
263:15: 8:53	915	23	100	466	653	533	33	50	1195	134
263:15: 9:53	915	24	100	466	644	526	35	50	1195	134
263:15:10:53	915	24	100	466	643	528	27	50	1195	134
263:15:11:52	914	24	100	466	643	525	33	50	1195	134
263:15:12:53	913	24	100	466	644	525	32	50	1195	134
263:15:13:53	912	23	100	466	647	530	25	50	1195	134
263:15:14:52	911	24	100	466	640	524	24	50	1195	134
263:15:15:53	910	25	100	466	640	524	29	50	1195	133
263:15:16:52	908	23	100	466	641	524	28	50	1195	134
263:15:17:53	907	23	100	466	642	527	27	50	1195	133
263:15:18:52	907	24	100	466	640	521	24	50	1195	134
263:15:19:52	906	23	100	466	642	527	28	50	1195	133
263:15:20:53	905	23	100	466	643	526	26	50	1195	133
263:15:21:53	904	22	100	466	649	530	30	50	1195	134
263:15:22:52	903	21	100	466	654	536	28	50	1195	133
263:15:23:52	902	23	100	466	658	537	34	50	1195	133
263:15:24:53	902	22	100	466	658	537	33	50	1195	133
263:15:25:52	901	22	100	466	663	544	41	50	1195	133
263:15:26:53	901	23	100	466	655	536	26	50	1195	133
263:15:27:52	901	22	100	466	649	531	25	50	1195	133
263:15:28:53	900	23	100	466	643	528	18	50	1195	133
263:15:29:53	900	22	100	467	641	525	20	50	1195	133
263:15:30:53	900	21	100	467	640	525	8	50	1195	133
263:15:31:52	900	22	100	467	644	528	11	50	1195	133
263:15:32:52	901	23	100	467	638	523	10	50	1195	133
263:15:33:52	901	22	100	467	626	514	7	50	1195	133
263:15:34:53	901	25	100	467	615	504	17	50	1195	133
263:15:35:53	901	23	100	466	558	455	24	50	1195	133
263:15:36:52	902	23	100	466	564	462	21	50	1195	133
263:15:37:52	902	25	100	466	585	480	23	50	1195	133
263:15:38:53	901	25	100	467	570	468	14	50	1195	133
263:15:39:53	901	26	100	466	514	421	22	50	1195	133
263:15:40:53	901	26	100	466	502	412	23	50	1195	133
263:15:41:53	901	17	98	465	160	124	54	50	1195	134
263:15:42:53	899	17	98	464	161	126	52	50	1194	135

C65

DAY 263 1984 DATA.7:00-17:00

TIME DAY:HR:MI:SE	TT583 DEC F	AZT581 PERCENT	PFT581 .01 LAG	ET581 VAC	IT581 AMPS	JT581 KWATTS	VT581 KVARs	ST581 PERCENT	ST582 RPM	TE503 DEC F
263:15:43:52	898	16	99	464	158	133	26	50	1195	136
263:15:44:53	896	12	100	461	8	0	0	50	1189	136
263:15:45:53	871	2	100	3	0	0	0	0	540	136
263:15:46:53	863	1	100	0	0	0	0	0	247	133
263:15:47:53	858	0	100	0	0	0	0	0	75	124
263:15:48:53	856	0	100	0	0	0	0	0	0	120
263:15:49:53	854	0	100	0	0	0	0	0	0	116
263:15:50:53	850	0	100	0	0	0	0	0	0	114
263:15:51:53	847	0	100	0	0	0	0	0	0	111
263:15:52:52	848	0	100	0	0	0	0	0	0	109
263:15:53:53	844	0	100	0	0	0	0	0	0	107
263:15:54:52	842	0	100	0	0	0	0	0	0	105
263:15:55:52	837	0	100	0	0	0	0	0	0	104
263:15:56:52	838	0	100	0	0	0	0	0	0	102
263:15:57:53	840	1	100	0	0	0	0	0	0	101
263:15:58:53	836	1	100	0	0	0	0	0	0	100
263:15:59:52	835	1	100	0	0	0	0	0	0	99
263:16: 0:53	831	0	100	0	0	0	0	0	0	97
263:16: 1:53	830	0	100	0	0	0	0	0	0	97
263:16: 2:52	827	0	100	0	0	0	0	0	0	96
263:16: 3:53	825	0	100	0	0	0	0	0	0	96
263:16: 4:53	824	0	100	0	0	0	0	0	0	96
263:16: 5:53	824	0	100	0	0	0	0	0	0	98
263:16: 6:52	823	0	100	0	0	0	0	0	0	100
263:16: 7:53	820	0	100	0	0	0	0	0	0	102
263:16: 8:53	820	0	100	0	0	0	0	0	0	103
263:16: 9:52	818	0	100	0	0	0	0	0	0	104
263:16:10:52	815	0	100	0	0	0	0	0	0	105
263:16:11:52	815	0	100	0	0	0	0	0	0	105
263:16:12:52	813	0	100	0	0	0	0	0	0	104
263:16:13:52	811	0	100	0	0	0	0	0	0	105
263:16:14:52	809	0	100	0	0	0	0	0	0	105
263:16:15:53	808	0	100	0	0	0	0	0	0	105
263:16:16:53	806	0	100	0	0	0	0	0	0	105
263:16:17:53	803	0	100	0	0	0	0	0	0	105
263:16:18:54	800	0	100	0	0	0	0	0	0	105
263:16:19:53	798	0	100	0	0	0	0	0	0	104
263:16:20:53	797	0	100	0	0	0	0	0	0	104
263:16:21:53	797	0	100	0	0	0	0	0	0	104
263:16:22:52	796	0	100	0	0	0	0	0	0	104
263:16:23:53	787	0	100	0	0	0	0	0	0	104
263:16:24:52	780	0	100	0	0	0	0	0	0	104
263:16:25:53	789	0	100	0	0	0	0	0	0	104
263:16:26:52	776	0	100	0	0	0	0	0	0	104
263:16:27:52	774	0	100	0	0	0	0	0	0	104
263:16:28:53	776	0	100	0	0	0	0	0	0	104
263:16:29:53	777	0	100	0	0	0	0	0	0	104
263:16:30:53	778	0	100	0	0	0	0	0	0	104
263:16:31:53	779	0	100	0	0	0	0	0	0	104
263:16:32:53	779	0	100	0	0	0	0	0	0	104
263:16:33:52	777	0	100	0	0	0	0	0	0	104
263:16:34:52	777	0	100	0	0	0	0	0	0	104
263:16:35:52	775	0	100	0	0	0	0	0	0	104
263:16:36:53	774	0	100	0	0	0	0	0	0	104
263:16:37:52	772	0	100	0	0	0	0	0	0	104
263:16:38:52	770	0	100	0	0	0	0	0	0	104

C66

TIME DAY:HR:MI:SE	TE505 DEG F	TE506 DEG F	TE508 DEG F	TE582 DEG F	TE161 DEG F	LT161 INCH	LT201 INCH	LT221 INCH	SP.EST DEG F	SP.DI. INCH
263:11:59:53	92	90	70	63	581	20	23	20	850	0
263:12: 0:53	94	90	70	63	581	20	23	20	850	0
263:12: 1:54	95	93	69	63	580	20	23	20	850	0
263:12: 2:53	96	94	68	62	580	20	23	20	850	0
263:12: 3:53	97	95	68	62	580	20	23	20	850	0
263:12: 4:53	98	96	68	61	580	20	23	20	850	0
263:12: 5:53	99	97	68	61	579	20	23	20	850	0
263:12: 6:52	100	97	67	61	579	20	23	20	850	0
263:12: 7:53	102	99	68	61	578	20	22	20	850	0
263:12: 8:53	103	99	68	60	578	22	23	20	850	0
263:12: 9:54	105	100	69	61	576	21	21	20	850	0
263:12:10:53	107	104	70	61	713	20	22	20	850	0
263:12:11:53	109	108	71	61	876	25	23	20	850	0
263:12:12:53	111	107	69	60	895	17	22	20	850	0
263:12:13:53	111	108	68	60	923	21	22	20	850	0
263:12:14:53	113	108	68	60	933	19	22	20	850	0
263:12:15:53	114	111	71	60	937	21	23	20	850	0
263:12:16:53	117	113	72	60	954	18	24	20	850	0
263:12:17:53	119	112	73	60	962	19	22	20	850	0
263:12:18:53	122	120	74	60	967	24	23	20	850	0
263:12:19:53	118	110	74	60	973	21	24	20	850	0
263:12:20:53	119	112	75	61	985	18	22	20	850	0
263:12:21:53	124	120	75	61	992	21	23	20	850	0
263:12:22:53	127	117	75	61	983	19	23	20	850	0
263:12:23:53	129	118	75	61	987	22	22	20	850	0
263:12:24:53	130	128	75	61	993	20	23	19	850	0
263:12:25:53	132	126	76	61	983	21	24	20	850	0
263:12:26:53	135	124	76	61	983	20	22	21	850	0
263:12:27:53	119	116	77	62	987	20	22	20	850	0
263:12:28:53	117	110	77	63	982	21	23	20	850	0
263:12:29:52	115	114	78	63	984	19	22	20	850	0
263:12:30:53	114	104	79	64	985	20	22	20	850	0
263:12:31:53	113	104	80	64	989	20	23	20	850	0
263:12:32:53	113	102	80	65	989	21	24	20	850	0
263:12:33:53	112	102	80	65	987	20	22	20	850	0
263:12:34:53	111	103	80	65	989	20	22	20	850	0
263:12:35:53	111	106	81	66	987	21	23	20	850	0
263:12:36:53	110	110	81	66	989	19	23	20	850	0
263:12:37:53	111	104	82	67	997	21	23	20	850	0
263:12:38:53	110	106	82	67	997	20	23	20	850	0
263:12:39:53	111	103	83	67	999	19	23	20	850	0
263:12:40:53	110	108	83	67	996	22	23	20	850	0
263:12:41:53	110	107	83	67	1004	18	23	20	850	0
263:12:42:53	111	108	83	67	1005	21	23	20	850	0
263:12:43:53	110	108	83	67	1010	21	23	20	850	0
263:12:44:54	115	109	83	68	1008	20	23	20	850	0
263:12:45:53	123	120	83	67	1014	21	23	20	850	0
263:12:46:53	126	123	83	67	1015	19	23	20	850	0
263:12:47:53	129	121	83	66	1008	20	23	20	850	0
263:12:48:54	131	123	83	65	1010	22	23	20	850	0
263:12:49:53	134	127	83	65	1009	24	23	20	850	0
263:12:50:53	136	124	83	64	1003	19	22	20	850	0
263:12:51:53	128	121	83	64	1019	21	22	20	850	0
263:12:52:53	129	130	83	65	1006	21	22	20	850	0
263:12:53:53	131	131	83	64	1010	19	21	20	850	0
263:12:54:53	133	123	83	64	1010	19	21	20	850	0

C67

DAY 263 1984 DATA.7:00-17:00

TIME DAY:HR:MI:SE	TE505 DEG F	TE506 DEG F	TE508 DEG F	TE582 DEG F	TE161 DEG F	LT161 INCH	LT201 INCH	LT221 INCH	SP.EST DEG F	SP.DL INCH
263:12:55:53	133	121	83	64	1009	21	21	20	850	0
263:12:56:53	129	117	83	65	1013	20	20	20	850	0
263:12:57:53	132	126	83	65	1014	17	20	21	850	0
263:12:58:53	133	128	83	64	1004	21	22	20	850	0
263:12:59:53	130	118	83	64	988	21	22	20	850	0
263:13:0:54	130	128	83	65	984	22	23	20	850	0
263:13:1:53	131	125	84	65	986	21	23	20	850	0
263:13:2:52	133	123	84	65	985	20	22	20	850	0
263:13:3:53	131	130	84	65	986	19	23	20	850	0
263:13:4:53	131	126	85	66	989	19	23	20	850	0
263:13:5:53	131	120	85	66	990	19	22	20	850	0
263:13:6:53	133	119	85	66	989	19	24	20	850	0
263:13:7:53	132	121	85	66	988	20	23	20	850	0
263:13:8:53	133	124	85	66	989	20	22	20	850	0
263:13:9:54	133	121	86	67	989	19	23	20	850	0
263:13:10:53	133	120	86	67	990	19	24	20	850	0
263:13:11:53	132	120	87	67	990	20	22	20	850	0
263:13:12:53	132	120	87	67	990	22	23	20	850	0
263:13:13:53	127	118	87	68	862	20	24	20	850	0
263:13:14:53	125	118	88	68	1003	18	21	20	850	0
263:13:15:53	124	123	89	69	980	21	22	20	850	0
263:13:16:53	125	117	89	69	955	19	23	20	850	0
263:13:17:53	127	122	89	69	944	18	24	19	850	0
263:13:18:52	129	116	89	70	961	19	22	20	850	0
263:13:19:53	129	122	89	69	966	22	23	19	850	0
263:13:20:53	131	122	89	69	963	19	24	20	850	0
263:13:21:53	132	121	89	69	965	20	22	20	850	0
263:13:22:53	132	124	89	69	976	20	22	20	850	0
263:13:23:53	134	123	90	69	979	21	22	20	850	0
263:13:24:53	132	126	90	69	985	20	23	20	850	0
263:13:25:53	132	122	90	69	990	19	23	20	850	0
263:13:26:53	133	124	90	69	991	21	23	20	850	0
263:13:27:53	132	125	90	69	990	19	24	20	850	0
263:13:28:53	133	127	90	69	989	21	24	20	850	0
263:13:29:53	132	122	90	69	992	20	22	20	850	0
263:13:30:53	131	128	90	69	991	20	22	20	850	0
263:13:31:53	128	122	90	69	989	18	23	20	850	0
263:13:32:54	126	113	91	70	988	20	23	20	850	0
263:13:33:53	125	119	91	70	992	22	24	20	850	0
263:13:34:53	125	120	91	71	996	21	22	20	850	0
263:13:35:53	123	114	92	71	995	19	22	20	850	0
263:13:36:53	123	112	92	71	991	21	23	20	850	0
263:13:37:53	123	111	92	71	983	20	23	20	850	0
263:13:38:53	123	110	92	71	990	20	24	20	850	0
263:13:39:53	122	117	92	71	987	21	23	20	850	0
263:13:40:53	122	110	93	71	990	21	22	20	850	0
263:13:41:53	121	120	93	71	991	21	23	20	850	0
263:13:42:54	121	113	93	71	994	19	23	20	850	0
263:13:43:53	121	111	93	71	994	21	23	20	850	0
263:13:44:53	121	121	93	71	998	19	22	20	850	0
263:13:45:53	122	117	93	71	998	21	22	20	850	0
263:13:46:53	122	115	93	71	999	20	23	20	850	0
263:13:47:53	122	114	93	71	1001	20	24	20	850	0
263:13:48:53	122	120	93	71	999	19	22	20	850	0
263:13:49:53	123	112	93	71	1000	20	22	20	850	0
263:13:50:53	122	117	93	71	1000	20	22	20	850	0

C-68

TIME DAY:HR:MI:SE	TE505 DEC F	TE506 DEC F	TE508 DEC F	TE582 DEC F	TE161 DEC F	LT161 INCH	LT201 INCH	LT221 INCH	SP.EST DEC F	SP.DL INCH
263:13:51:53	123	122	94	71	1001	20	22	20	850	0
263:13:52:53	122	115	93	72	1002	20	23	20	850	0
263:13:53:52	123	112	94	72	1002	21	23	20	850	0
263:13:54:53	123	115	94	72	1002	19	23	20	850	0
263:13:55:54	123	113	94	72	1005	21	23	21	850	0
263:13:56:53	123	110	94	72	1005	20	23	20	850	0
263:13:57:52	123	118	94	72	1005	20	24	20	850	0
263:13:58:53	122	118	94	72	1005	20	22	20	850	0
263:13:59:53	122	121	94	72	1006	20	22	20	850	0
263:14:0:54	123	118	94	72	1009	19	23	20	850	0
263:14:1:53	123	112	94	72	1007	19	24	19	850	0
263:14:2:52	123	116	95	72	1006	19	23	21	850	0
263:14:3:53	123	117	95	72	1009	21	22	20	850	0
263:14:4:53	123	115	95	72	1010	20	23	20	850	0
263:14:5:53	123	121	95	72	1008	19	24	20	850	0
263:14:6:53	123	111	95	71	1010	21	23	20	850	0
263:14:7:52	124	111	94	71	1013	20	22	20	850	0
263:14:8:53	123	118	94	71	1014	20	23	20	850	0
263:14:9:53	123	114	94	71	1018	18	24	20	850	0
263:14:10:52	123	115	94	71	1010	20	22	20	850	0
263:14:11:53	123	119	95	71	1008	21	23	20	850	0
263:14:12:52	123	120	94	71	1006	19	23	20	850	0
263:14:13:53	123	120	94	71	1007	19	23	20	850	0
263:14:14:53	123	115	95	71	1009	19	22	19	850	0
263:14:15:53	123	115	95	71	1007	21	23	20	850	0
263:14:16:52	122	122	95	71	1019	21	24	20	850	0
263:14:17:52	123	113	95	71	1016	20	23	20	850	0
263:14:18:52	122	120	95	71	1006	17	22	20	850	0
263:14:19:52	122	119	95	71	1006	21	23	21	850	0
263:14:20:52	123	121	95	71	1007	18	23	20	850	0
263:14:21:53	123	111	95	71	1003	20	22	20	850	0
263:14:22:53	123	112	95	71	1004	18	23	19	850	0
263:14:23:52	124	116	95	71	1007	20	24	20	850	0
263:14:24:52	124	119	95	71	1010	20	22	20	850	0
263:14:25:53	122	115	95	71	1006	21	22	20	850	0
263:14:26:53	123	111	95	71	1007	21	23	20	850	0
263:14:27:53	123	117	96	71	1014	20	23	20	850	0
263:14:28:53	122	114	96	71	1009	21	22	20	850	0
263:14:29:53	123	116	96	72	1011	22	23	20	850	0
263:14:30:53	124	115	96	72	1014	21	23	20	850	0
263:14:31:53	123	114	96	71	1007	17	23	20	850	0
263:14:32:53	123	118	96	71	1006	17	23	20	850	0
263:14:33:53	123	115	96	71	1009	18	22	20	850	0
263:14:34:53	123	113	96	71	1010	19	23	20	850	0
263:14:35:53	123	115	96	71	1006	20	23	20	850	0
263:14:36:53	123	122	96	71	1009	19	22	20	850	0
263:14:37:53	123	118	96	71	1010	21	23	20	850	0
263:14:38:53	122	122	96	71	1013	22	24	20	850	0
263:14:39:53	122	122	96	71	1015	22	23	20	850	0
263:14:40:53	124	118	96	71	1011	21	23	19	850	0
263:14:41:53	123	115	96	71	1007	21	23	20	850	0
263:14:42:53	123	113	96	71	1008	21	23	20	850	0
263:14:43:54	123	111	96	71	1010	20	22	20	850	0
263:14:44:53	123	121	96	71	1009	20	22	20	850	0
263:14:45:53	123	113	96	71	1007	20	24	20	850	0
263:14:46:53	123	117	96	72	1012	19	22	20	850	0

C69

## DAY 263 1984 DATA.7:00-17:00

TIME DAY:HR:MI:SE	TE505 DEG F	TE506 DEG F	TE508 DEG F	TE582 DEG F	TE161 DEG F	LT161 INCH	LT201 INCH	LT221 INCH	SP.EST DEG F	SP.DL INCH
263:14:47:53	122	122	96	72	1010	20	23	20	850	0
263:14:48:53	123	116	97	72	1009	20	23	20	850	0
263:14:49:52	123	110	97	72	1009	21	22	19	850	0
263:14:50:53	123	117	97	72	1012	20	24	20	850	0
263:14:51:53	123	118	97	72	1010	20	22	20	850	0
263:14:52:52	123	112	97	72	1009	21	23	20	850	0
263:14:53:53	123	116	97	72	1009	20	24	20	850	0
263:14:54:53	123	121	97	72	1010	21	22	20	850	0
263:14:55:53	122	112	97	72	1009	21	23	20	850	0
263:14:56:53	123	118	97	72	1009	19	23	20	850	0
263:14:57:53	123	120	97	72	1011	15	21	20	850	0
263:14:58:53	123	120	97	72	1013	23	21	20	850	0
263:14:59:54	123	121	97	72	982	16	21	20	850	0
263:15:0:53	122	121	97	72	916	22	21	20	850	0
263:15:1:52	123	120	97	72	924	18	21	20	850	0
263:15:2:52	123	115	98	72	920	23	21	20	850	0
263:15:3:52	123	116	98	72	920	18	21	20	850	0
263:15:4:52	123	117	98	72	925	10	21	20	850	0
263:15:5:52	123	112	98	72	923	21	21	20	850	0
263:15:6:53	123	111	98	73	915	19	22	20	850	0
263:15:7:52	123	118	98	72	916	21	22	20	850	0
263:15:8:53	123	114	98	73	920	19	22	20	850	0
263:15:9:53	123	115	98	73	919	21	22	20	850	0
263:15:10:53	123	118	99	73	919	19	22	20	850	0
263:15:11:52	123	113	99	73	919	21	23	20	850	0
263:15:12:53	123	116	99	73	919	19	24	20	850	0
263:15:13:53	123	116	99	73	918	21	22	20	850	0
263:15:14:52	123	118	99	73	924	20	23	20	850	0
263:15:15:53	123	112	99	72	930	20	24	20	850	0
263:15:16:52	122	122	98	73	939	20	22	20	850	0
263:15:17:53	123	118	98	73	944	19	23	20	850	0
263:15:18:52	123	121	99	73	951	21	23	20	850	0
263:15:19:52	123	112	98	72	958	22	24	20	850	0
263:15:20:53	123	118	98	72	971	19	24	20	850	0
263:15:21:53	124	114	99	72	979	23	24	20	850	0
263:15:22:52	123	121	98	72	975	20	22	20	850	0
263:15:23:52	123	117	98	72	976	19	23	19	850	0
263:15:24:53	123	121	98	72	976	21	23	20	850	0
263:15:25:52	123	118	98	72	987	20	22	20	850	0
263:15:26:53	123	122	98	72	991	21	23	20	850	0
263:15:27:52	123	115	98	72	985	21	24	20	850	0
263:15:28:53	123	111	98	72	982	21	22	20	850	0
263:15:29:53	123	122	98	72	987	22	23	20	850	0
263:15:30:53	123	116	98	72	991	22	23	20	850	0
263:15:31:52	123	115	98	72	993	20	24	20	850	0
263:15:32:52	123	120	98	72	992	20	22	19	850	0
263:15:33:52	123	117	98	72	987	21	23	20	850	0
263:15:34:53	123	122	98	72	989	21	23	20	850	0
263:15:35:53	123	121	98	72	989	21	24	20	850	0
263:15:36:52	122	113	98	72	991	20	23	20	850	0
263:15:37:52	123	115	98	72	991	22	22	20	850	0
263:15:38:53	122	112	98	72	993	20	23	20	850	0
263:15:39:53	123	119	98	72	992	20	23	20	850	0
263:15:40:53	123	117	98	71	989	21	22	19	850	0
263:15:41:53	123	120	98	72	989	18	24	20	850	0
263:15:42:53	122	116	98	72	991	21	22	20	850	0

C70

TIME DAY:HR:MI:SE	TE505 DEG F	TE506 DEG F	TE508 DEG F	TE582 DEG F	TE161 DEG F	LT161 INCH	LT201 INCH	LT221 INCH	SP. EST DEG F	SP. DL INCH
263:15:43:52	122	115	98	72	992	20	23	20	850	0
263:15:44:53	120	115	99	75	990	20	23	20	850	0
263:15:45:53	118	110	97	76	990	21	24	20	850	0
263:15:46:53	115	109	93	75	989	21	22	20	850	0
263:15:47:53	113	108	90	74	990	19	23	20	850	0
263:15:48:53	111	106	89	73	991	20	24	20	850	0
263:15:49:53	108	104	89	72	990	20	22	20	850	0
263:15:50:53	105	99	88	71	990	21	23	20	850	0
263:15:51:53	102	97	88	70	990	21	23	20	850	0
263:15:52:52	100	96	88	69	990	21	22	20	850	0
263:15:53:53	98	95	87	68	991	19	23	20	850	0
263:15:54:52	97	94	87	68	989	20	23	20	850	0
263:15:55:52	95	92	86	67	989	19	22	20	850	0
263:15:56:52	93	91	86	67	990	19	22	20	850	0
263:15:57:53	92	90	86	67	990	19	22	20	850	0
263:15:58:53	91	89	85	66	991	19	22	20	850	0
263:15:59:52	90	88	85	65	989	20	22	20	850	0
263:16: 0:53	89	87	84	65	989	20	22	20	850	0
263:16: 1:53	88	86	84	65	991	19	21	20	850	0
263:16: 2:52	87	85	83	65	991	19	21	22	850	0
263:16: 3:53	94	92	83	64	991	19	21	22	850	0
263:16: 4:53	97	94	83	64	990	19	20	22	850	0
263:16: 5:53	100	96	82	63	989	19	20	22	850	0
263:16: 6:52	103	97	82	63	987	17	20	22	850	0
263:16: 7:53	106	98	82	64	986	19	21	22	850	0
263:16: 8:53	108	98	81	64	985	19	22	22	850	0
263:16: 9:52	110	98	81	64	986	20	24	22	850	0
263:16:10:52	111	99	81	64	981	22	22	22	850	0
263:16:11:52	112	99	81	64	860	19	21	22	850	0
263:16:12:52	113	99	81	64	681	17	20	22	850	0
263:16:13:52	114	100	81	64	613	16	19	22	850	0
263:16:14:52	115	100	81	64	589	19	18	22	850	0
263:16:15:53	116	101	82	64	582	20	17	22	850	0
263:16:16:53	117	101	82	64	579	20	16	22	850	0
263:16:17:53	117	101	82	65	579	20	17	22	850	0
263:16:18:54	118	101	82	64	578	7	21	22	850	0
263:16:19:53	118	101	83	64	578	2	25	22	850	0
263:16:20:53	119	101	83	65	575	2	26	22	850	0
263:16:21:53	119	102	83	65	575	2	27	22	850	0
263:16:22:52	120	102	84	65	576	2	27	22	850	0
263:16:23:53	120	102	84	65	577	2	28	22	850	0
263:16:24:52	120	102	85	65	578	2	28	22	850	0
263:16:25:53	120	102	85	65	578	2	29	22	850	0
263:16:26:52	121	103	85	65	579	2	29	22	850	0
263:16:27:52	121	102	86	66	583	2	29	22	850	0
263:16:28:53	121	103	86	66	584	2	30	23	850	0
263:16:29:53	121	103	86	66	586	2	30	22	850	0
263:16:30:53	121	103	86	66	586	2	31	22	850	0
263:16:31:53	121	103	87	66	587	2	31	23	850	0
263:16:32:53	122	103	87	66	587	2	31	23	850	0
263:16:33:52	122	103	87	66	588	2	32	23	850	0
263:16:34:52	122	103	87	66	589	2	32	23	850	0
263:16:35:52	122	103	87	66	590	2	32	22	850	0
263:16:36:53	122	103	87	67	591	2	33	23	850	0
263:16:37:52	122	103	88	67	593	2	33	23	850	0
263:16:38:52	122	103	88	67	593	2	33	24	850	0

C71

## DAY 263 1984 DATA.7:00-17:00

TIME DAY:HR:MI:SE	SP.SP PSI	SP.ST DEG F	IE161 PERCENT	IE162 PERCENT	IE201 PERCENT	IE221 PERCENT	PT180 PSI	LT281 INCH	LT291 INCH	SUN W/SQ M
263:11:59:53	1100	950	98	37	77	16	313	65	69	922
263:12: 0:53	1100	950	98	35	14	9	313	66	68	921
263:12: 1:54	1100	950	98	38	71	14	313	67	67	922
263:12: 2:53	1100	950	98	36	27	7	313	67	66	923
263:12: 3:53	1100	950	98	37	74	12	313	67	65	924
263:12: 4:53	1100	950	98	38	13	13	313	68	65	924
263:12: 5:53	1100	950	98	36	72	15	313	69	64	924
263:12: 6:52	1100	950	98	37	22	13	313	69	63	925
263:12: 7:53	1100	950	98	38	64	9	313	70	62	929
263:12: 8:53	1100	950	98	47	28	5	308	70	61	931
263:12: 9:54	1100	950	98	60	97	22	296	72	60	931
263:12:10:53	1100	950	98	54	87	19	301	72	60	932
263:12:11:53	1100	950	13	0	77	10	297	72	59	932
263:12:12:53	1100	950	40	0	97	8	297	71	60	931
263:12:13:53	1100	950	42	0	81	17	300	71	61	930
263:12:14:53	1100	950	47	0	82	17	300	70	62	931
263:12:15:53	1100	950	38	0	97	20	300	70	63	933
263:12:16:53	1100	950	25	0	33	7	299	69	63	932
263:12:17:53	1100	950	52	0	97	19	301	69	64	931
263:12:18:53	1100	950	39	0	96	6	301	69	64	928
263:12:19:53	1100	950	23	0	49	12	301	68	65	928
263:12:20:53	1100	950	55	0	93	21	303	69	65	927
263:12:21:53	1100	950	47	0	96	27	302	68	65	927
263:12:22:53	1100	950	40	0	50	13	301	68	66	927
263:12:23:53	1100	950	44	0	85	8	301	68	66	930
263:12:24:53	1100	950	32	0	96	8	301	68	66	931
263:12:25:53	1100	950	35	0	97	13	300	67	66	933
263:12:26:53	1100	950	39	0	97	18	301	68	67	934
263:12:27:53	1100	950	44	0	96	28	302	67	67	934
263:12:28:53	1100	950	40	40	97	13	302	67	67	933
263:12:29:52	1100	950	43	0	37	13	301	67	67	933
263:12:30:53	1100	950	44	0	92	18	301	67	67	933
263:12:31:53	1100	950	43	0	92	19	302	66	68	930
263:12:32:53	1100	950	40	0	92	17	301	66	68	929
263:12:33:53	1100	950	37	0	92	8	301	67	68	928
263:12:34:53	1100	950	43	0	95	19	302	66	68	927
263:12:35:53	1100	950	36	0	95	8	300	66	69	928
263:12:36:53	1100	950	53	0	95	9	300	65	70	929
263:12:37:53	1100	950	23	0	95	11	298	65	70	930
263:12:38:53	1100	950	53	0	95	24	299	64	71	927
263:12:39:53	1100	950	29	0	95	15	299	64	71	927
263:12:40:53	1100	950	46	0	95	14	300	64	72	927
263:12:41:53	1100	950	47	0	95	22	299	64	72	928
263:12:42:53	1100	950	32	0	95	19	298	63	73	931
263:12:43:53	1100	950	56	0	95	19	302	63	74	936
263:12:44:54	1100	950	33	0	95	4	299	62	75	938
263:12:45:53	1100	950	42	0	95	16	299	62	75	937
263:12:46:53	1100	950	50	0	95	6	300	62	75	938
263:12:47:53	1100	950	28	0	95	14	297	61	76	940
263:12:48:54	1100	950	53	0	95	12	300	61	77	937
263:12:49:53	1100	950	27	0	95	14	299	61	77	936
263:12:50:53	1100	950	37	0	97	20	299	61	78	939
263:12:51:53	1100	950	38	0	80	14	302	60	78	940
263:12:52:53	1100	950	36	0	96	14	297	60	79	940
263:12:53:53	1100	950	37	0	96	9	298	60	79	939
263:12:54:53	1100	950	50	0	93	14	300	59	80	940

C72



## DAY 263 1984 DATA.7:00-17:00

TIME DAY:HR:MI:SE	SP.SP PSI	SP.ST DEG F	IE161 PERCENT	IE162 PERCENT	IE201 PERCENT	IE221 PERCENT	PT180 PSI	LT281 INCH	LT291 INCH	SUN W/SQ M
263:12:55:53	1100	950	34	0	97	10	299	59	80	938
263:12:56:53	1100	950	52	0	97	12	300	59	81	938
263:12:57:53	1100	950	35	0	97	25	301	58	81	937
263:12:58:53	1100	950	47	0	97	16	304	58	81	936
263:12:59:53	1100	950	41	0	86	34	306	58	81	935
263:13:0:54	1100	950	46	0	86	9	306	58	81	933
263:13:1:53	1100	950	44	0	52	13	306	58	81	936
263:13:2:52	1100	950	52	0	80	12	306	58	81	937
263:13:3:53	1100	950	51	0	86	20	306	58	80	940
263:13:4:53	1100	950	49	0	41	11	305	59	81	941
263:13:5:53	1100	950	49	0	90	38	305	59	81	940
263:13:6:53	1100	950	52	0	90	16	306	59	80	940
263:13:7:53	1100	950	54	0	59	23	305	59	80	943
263:13:8:53	1100	950	43	0	73	25	305	59	80	943
263:13:9:54	1100	950	46	0	79	17	305	59	80	944
263:13:10:53	1100	950	52	0	45	9	300	59	80	943
263:13:11:53	1100	950	65	0	97	21	307	59	80	942
263:13:12:53	1100	950	70	0	97	9	307	59	80	940
263:13:13:53	1100	950	97	0	33	22	308	59	80	939
263:13:14:53	1100	950	96	0	97	19	304	59	80	940
263:13:15:53	1100	950	62	0	96	15	304	59	80	940
263:13:16:53	1100	950	40	0	93	10	303	59	80	941
263:13:17:53	1100	950	57	0	50	20	303	59	80	940
263:13:18:52	1100	950	50	0	75	14	304	59	80	938
263:13:19:53	1100	950	36	0	97	25	303	59	80	939
263:13:20:53	1100	950	32	0	43	11	301	59	79	938
263:13:21:53	1100	950	48	0	96	11	302	59	80	937
263:13:22:53	1100	950	44	0	97	18	303	59	80	938
263:13:23:53	1100	950	48	0	89	16	303	59	80	940
263:13:24:53	1100	950	41	0	89	28	302	59	80	939
263:13:25:53	1100	950	55	0	89	16	302	59	80	940
263:13:26:53	1100	950	38	0	89	20	302	59	80	941
263:13:27:53	1100	950	49	0	89	13	302	59	80	943
263:13:28:53	1100	950	46	0	89	22	302	59	80	942
263:13:29:53	1100	950	40	0	91	10	303	59	80	940
263:13:30:53	1100	950	43	0	89	10	303	59	80	941
263:13:31:53	1100	950	22	0	89	7	300	59	80	936
263:13:32:54	1100	950	53	0	89	20	303	59	80	939
263:13:33:53	1100	950	34	0	89	16	303	59	80	938
263:13:34:53	1100	950	40	0	96	27	301	59	81	937
263:13:35:53	1100	950	47	0	97	11	304	59	81	937
263:13:36:53	1100	950	47	0	96	30	303	59	81	938
263:13:37:53	1100	950	45	0	97	4	303	58	81	938
263:13:38:53	1100	950	47	0	96	5	302	58	81	937
263:13:39:53	1100	950	45	0	59	32	303	58	81	937
263:13:40:53	1100	950	43	0	97	11	303	58	82	937
263:13:41:53	1100	950	38	0	96	8	304	58	82	938
263:13:42:54	1100	950	50	0	96	17	304	58	82	938
263:13:43:53	1100	950	48	0	52	25	304	58	82	940
263:13:44:53	1100	950	48	0	94	15	305	58	82	938
263:13:45:53	1100	970	43	0	97	16	303	58	82	938
263:13:46:53	1100	970	43	0	96	17	303	58	82	939
263:13:47:53	1100	970	43	0	96	22	303	58	82	941
263:13:48:53	1100	970	41	0	82	26	303	58	82	942
263:13:49:53	1100	970	53	0	91	17	303	58	82	942
263:13:50:53	1100	970	47	0	82	20	304	58	82	938

C-73

## DAY 263 1984 DATA.7:00-17:00

TIME DAY:HR:MI:SE	SP.SP PSI	SP.ST DEG F	IE161 PERCENT	IE162 PERCENT	IE201 PERCENT	IE221 PERCENT	PT180 PSI	LT281 INCH	LT291 INCH	SUN W/SQ M
263:13:51:53	1100	970	45	0	82	12	304	58	81	936
263:13:52:53	1100	970	49	0	82	23	304	58	82	937
263:13:53:52	1100	970	43	0	82	33	303	58	82	936
263:13:54:53	1100	970	48	0	82	34	304	58	82	940
263:13:55:54	1100	970	41	0	82	32	303	58	82	940
263:13:56:53	1100	970	39	0	82	27	304	58	82	936
263:13:57:52	1100	970	44	0	82	28	304	58	81	931
263:13:58:53	1100	970	40	0	96	12	304	59	81	933
263:13:59:53	1100	970	50	0	89	11	304	58	81	933
263:14:0:54	1100	970	43	0	89	12	304	58	81	932
263:14:1:53	1100	970	40	0	90	31	302	58	81	932
263:14:2:52	1100	970	41	0	66	8	303	58	81	932
263:14:3:53	1100	970	39	0	66	16	303	59	81	932
263:14:4:53	1100	970	41	0	97	8	305	59	81	931
263:14:5:53	1100	970	59	0	96	15	305	59	81	925
263:14:6:53	1100	970	60	0	50	18	308	59	81	925
263:14:7:52	1100	970	49	0	77	13	305	59	80	930
263:14:8:53	1100	970	40	0	90	17	305	59	81	931
263:14:9:53	1100	970	53	0	90	20	304	59	80	927
263:14:10:52	1100	970	61	0	83	11	308	59	80	927
263:14:11:53	1100	970	48	0	88	37	304	59	80	927
263:14:12:52	1100	970	49	0	88	14	306	59	80	922
263:14:13:53	1100	970	76	0	55	15	310	59	80	921
263:14:14:53	1100	970	77	0	93	12	306	60	80	928
263:14:15:53	1100	970	70	0	93	32	307	59	80	925
263:14:16:52	1100	970	45	0	93	17	305	59	80	924
263:14:17:52	1100	970	41	0	57	6	304	60	79	922
263:14:18:52	1100	970	55	0	89	11	303	60	80	926
263:14:19:52	1100	970	42	0	95	14	302	60	79	924
263:14:20:52	1100	970	47	0	58	22	304	59	79	924
263:14:21:53	1100	970	41	0	96	18	304	60	79	922
263:14:22:53	1100	970	59	0	88	32	304	60	79	919
263:14:23:52	1100	970	49	0	88	14	306	60	79	919
263:14:24:52	1100	970	56	0	47	14	306	60	79	919
263:14:25:53	1100	970	47	0	84	17	304	60	79	917
263:14:26:53	1100	970	52	0	84	15	308	60	78	915
263:14:27:53	1100	970	40	0	44	10	305	61	78	915
263:14:28:53	1100	970	46	0	94	19	307	60	78	914
263:14:29:53	1100	970	50	0	96	23	306	61	78	913
263:14:30:53	1100	970	39	0	48	10	306	61	78	913
263:14:31:53	1100	970	42	0	96	15	303	61	78	908
263:14:32:53	1100	970	56	0	51	22	304	61	77	903
263:14:33:53	1100	970	55	0	96	18	304	61	77	905
263:14:34:53	1100	970	49	0	89	24	304	61	77	903
263:14:35:53	1100	970	46	0	52	17	306	61	77	905
263:14:36:53	1100	970	53	0	95	19	307	62	77	906
263:14:37:53	1100	970	61	0	88	15	308	62	76	906
263:14:38:53	1100	970	60	0	69	27	308	62	76	902
263:14:39:53	1100	970	43	0	69	17	307	62	76	905
263:14:40:53	1100	970	49	0	69	26	307	62	76	908
263:14:41:53	1100	970	57	0	69	10	307	62	76	908
263:14:42:53	1100	970	46	0	69	22	307	62	76	906
263:14:43:54	1100	970	55	0	69	14	307	62	75	905
263:14:44:53	1100	970	61	0	97	15	306	63	75	909
263:14:45:53	1100	970	48	0	96	14	306	62	75	909
263:14:46:53	1100	970	48	0	50	18	306	63	75	909

C-7A

TIME DAY:HR:MI:SE	SP.SP PSI	SP.ST DEG F	IE161 PERCENT	IE162 PERCENT	IE201 PERCENT	IE221 PERCENT	PT180 PSI	LT281 INCH	LT291 INCH	SUN W/SQ M
263:14:47:53	1100	970	50	0	96	13	305	63	74	905
263:14:48:53	1100	970	42	0	44	10	305	63	75	900
263:14:49:52	1100	970	40	0	95	7	305	63	75	902
263:14:50:53	1100	970	42	0	54	12	306	63	74	903
263:14:51:53	1100	970	51	0	53	14	306	63	74	903
263:14:52:52	1100	970	42	0	86	14	303	64	74	905
263:14:53:53	1100	970	37	0	54	26	306	64	74	909
263:14:54:53	1100	970	48	0	79	16	306	64	73	906
263:14:55:53	1100	970	48	0	84	19	307	64	73	905
263:14:56:53	1100	970	56	0	38	24	309	64	73	903
263:14:57:53	1100	970	56	0	96	27	295	64	73	901
263:14:58:53	1100	970	27	0	96	15	301	64	73	899
263:14:59:54	1100	970	66	0	81	9	299	64	74	900
263:15: 0:53	1100	970	42	0	86	17	301	64	73	900
263:15: 1:52	1100	970	51	0	97	16	300	64	74	900
263:15: 2:52	1100	970	31	0	96	9	301	64	74	899
263:15: 3:52	1100	970	37	0	87	21	298	64	74	898
263:15: 4:52	1100	970	42	0	91	14	299	64	74	897
263:15: 5:52	1100	970	41	0	96	14	300	63	74	893
263:15: 6:53	1100	970	41	0	96	24	300	63	74	891
263:15: 7:52	1100	970	39	0	96	11	301	63	74	893
263:15: 8:53	1100	970	45	0	90	15	301	63	74	890
263:15: 9:53	1100	970	36	0	96	20	301	63	74	889
263:15:10:53	1100	970	43	0	97	31	300	63	74	889
263:15:11:52	1100	970	33	0	97	12	302	63	74	887
263:15:12:53	1100	970	44	0	96	17	303	63	74	885
263:15:13:53	1100	970	41	0	87	25	304	63	74	881
263:15:14:52	1100	970	44	0	90	20	306	63	74	882
263:15:15:53	1100	970	52	0	90	14	306	63	74	881
263:15:16:52	1100	970	47	0	97	18	306	64	74	878
263:15:17:53	1100	970	65	0	79	26	309	63	74	880
263:15:18:52	1100	970	69	0	79	14	307	63	73	878
263:15:19:52	1100	970	41	0	79	13	304	63	73	875
263:15:20:53	1100	970	64	0	79	13	303	64	74	871
263:15:21:53	1100	970	48	0	79	27	305	64	74	867
263:15:22:52	1100	970	45	0	94	18	306	64	73	871
263:15:23:52	1100	970	66	0	97	17	306	64	73	868
263:15:24:53	1100	970	52	0	38	22	306	64	73	874
263:15:25:52	1100	970	49	0	97	15	304	64	73	871
263:15:26:53	1100	970	42	0	95	13	305	64	73	868
263:15:27:52	1100	970	46	0	48	22	305	64	73	868
263:15:28:53	1100	970	44	0	76	30	306	64	73	862
263:15:29:53	1100	970	40	0	81	6	305	64	73	864
263:15:30:53	1100	970	31	0	81	24	304	64	72	869
263:15:31:52	1100	970	37	0	50	16	304	64	72	865
263:15:32:52	1100	970	45	0	96	30	305	65	73	867
263:15:33:52	1100	970	48	0	77	22	305	65	72	867
263:15:34:53	1100	970	45	0	77	28	305	65	72	866
263:15:35:53	1100	970	47	0	77	15	306	65	72	864
263:15:36:52	1100	970	46	0	55	18	304	65	72	864
263:15:37:52	1100	970	39	0	89	15	304	65	72	865
263:15:38:53	1100	970	24	0	89	17	304	65	72	863
263:15:39:53	1100	970	39	0	49	8	304	65	72	859
263:15:40:53	1100	970	27	0	90	22	303	65	72	857
263:15:41:53	1100	970	45	0	90	12	303	64	72	859
263:15:42:53	1100	970	33	0	56	2	304	64	73	856

C-75

DAY 263 1984 DATA.7:00-17:00

TIME DAY:HR:MI:SE	SP.SP PSI	SP.ST DEC F	IE161 PERCENT	IE162 PERCENT	IE201 PERCENT	IE221 PERCENT	PT180 PSI	LT281 INCH	LT291 INCH	SUN W/SQ M
263:15:43:52	1100	970	37	0	82	8	304	64	73	857
263:15:44:53	1100	970	47	0	82	14	305	63	74	854
263:15:45:53	1100	970	45	0	34	3	306	63	75	855
263:15:46:53	1100	970	47	0	79	9	306	62	76	853
263:15:47:53	1100	970	52	0	86	6	306	62	76	851
263:15:48:53	1100	970	53	0	45	7	307	61	77	844
263:15:49:53	1100	970	51	0	96	8	306	61	78	845
263:15:50:53	1100	970	44	0	95	3	306	60	79	848
263:15:51:53	1100	970	48	0	55	10	307	60	80	845
263:15:52:52	1100	970	52	0	91	10	307	59	81	840
263:15:53:53	1100	970	56	0	93	5	307	58	82	834
263:15:54:52	1100	970	57	0	61	10	306	57	83	836
263:15:55:52	1100	970	53	0	96	8	305	57	84	840
263:15:56:52	1100	970	49	0	97	3	304	56	85	836
263:15:57:53	1100	970	43	0	92	3	304	56	86	837
263:15:58:53	1100	970	52	0	91	5	304	55	87	838
263:15:59:52	1100	970	42	0	97	1	304	54	88	833
263:16: 0:53	1100	970	42	0	97	13	304	54	89	835
263:16: 1:53	1100	970	48	0	95	0	305	53	91	837
263:16: 2:52	1100	970	57	0	97	0	304	52	92	837
263:16: 3:53	1100	970	45	0	97	0	304	51	93	836
263:16: 4:53	1100	970	49	0	96	0	304	51	95	834
263:16: 5:53	1100	970	48	0	96	0	304	50	96	836
263:16: 6:52	1100	970	69	0	97	0	309	49	97	833
263:16: 7:53	1100	970	61	0	97	0	311	48	97	831
263:16: 8:53	1100	970	60	0	90	0	312	48	98	833
263:16: 9:52	1100	970	60	0	90	0	312	47	99	830
263:16:10:52	1100	970	59	0	47	0	308	47	99	825
263:16:11:52	1100	970	39	0	96	0	304	46	101	824
263:16:12:52	1100	970	98	99	84	0	303	45	102	815
263:16:13:52	1100	970	98	46	96	0	303	46	102	818
263:16:14:52	1100	970	98	49	91	0	303	45	102	820
263:16:15:53	1100	970	98	50	97	0	302	46	102	817
263:16:16:53	1100	970	98	51	96	0	302	46	102	811
263:16:17:53	1100	970	98	41	96	0	316	46	102	808
263:16:18:54	1100	970	98	99	96	0	322	46	102	811
263:16:19:53	1100	970	98	99	0	0	0	49	102	805
263:16:20:53	1100	970	98	99	0	0	0	52	102	803
263:16:21:53	1100	970	98	99	0	0	0	53	102	803
263:16:22:52	1100	970	98	99	0	0	0	54	103	799
263:16:23:53	1100	970	98	99	0	0	0	54	102	806
263:16:24:52	1100	970	98	99	0	0	0	54	103	808
263:16:25:53	1100	970	98	99	0	0	0	54	103	808
263:16:26:52	1100	970	98	99	0	0	0	54	103	804
263:16:27:52	1100	970	98	99	0	0	0	54	103	805
263:16:28:53	1100	970	98	99	0	0	0	54	103	806
263:16:29:53	1100	970	98	99	0	0	0	54	103	805
263:16:30:53	1100	970	98	99	0	0	0	54	103	802
263:16:31:53	1100	970	98	99	0	0	0	54	103	802
263:16:32:53	1100	970	98	99	0	0	0	54	103	805
263:16:33:52	1100	970	98	99	0	0	0	54	103	804
263:16:34:52	1100	970	98	99	0	0	0	54	103	802
263:16:35:52	1100	970	98	99	0	0	0	54	103	801
263:16:36:53	1100	970	98	99	0	0	0	54	103	798
263:16:37:52	1100	970	98	99	0	0	0	54	103	795
263:16:38:52	1100	970	98	99	0	0	0	54	103	793

C-76

TIME DAY:HR:MI:SE	TE180 DEC F	TE181 DEC F	TE211 DEC F	TE231 DEC F	TE286 DEC F	TE387 DEC F	TE281 DEC F	TE282 DEC F	TE283 DEC F	TE291 DEC F
263:12:0:4	101	216	156	148	156	117	571	564	562	907
263:12:1:3	102	217	157	149	155	117	571	564	562	906
263:12:2:4	101	217	157	148	155	117	571	564	562	907
263:12:3:3	101	217	157	149	155	117	571	564	562	906
263:12:4:3	100	217	158	149	156	117	571	564	562	906
263:12:5:3	101	217	157	150	155	117	571	564	562	906
263:12:6:3	102	216	150	149	156	117	571	563	561	906
263:12:7:3	101	217	156	149	156	118	571	563	562	906
263:12:8:3	101	217	154	150	156	117	571	564	561	906
263:12:9:3	101	217	157	150	156	117	571	564	562	906
263:12:10:3	101	217	158	150	156	117	571	564	561	906
263:12:11:4	100	216	154	150	157	117	571	564	562	906
263:12:12:3	101	214	153	150	157	117	571	564	561	905
263:12:13:3	101	214	151	149	158	117	572	564	562	905
263:12:14:3	102	214	151	149	157	117	571	564	562	904
263:12:15:3	102	215	154	148	158	117	571	564	562	905
263:12:16:3	102	214	154	149	158	118	571	564	562	905
263:12:17:3	102	214	155	148	158	117	570	564	562	906
263:12:18:3	102	215	154	149	159	117	572	564	562	906
263:12:19:3	102	215	156	148	158	117	571	564	562	908
263:12:20:3	102	214	157	149	157	118	571	564	562	908
263:12:21:3	102	216	157	148	156	119	571	564	562	909
263:12:22:3	100	216	159	149	156	119	571	564	562	911
263:12:23:3	101	215	160	149	156	119	571	564	562	912
263:12:24:3	100	216	155	150	157	118	571	564	562	913
263:12:25:3	102	214	154	150	158	119	571	564	562	915
263:12:26:3	102	214	155	151	158	120	571	564	562	916
263:12:27:3	102	214	154	151	158	119	571	563	562	918
263:12:28:3	102	215	154	151	159	119	571	563	561	919
263:12:29:4	102	216	154	151	158	119	571	563	561	920
263:12:30:3	102	216	155	149	158	118	571	563	561	921
263:12:31:3	101	214	155	150	159	118	571	564	561	922
263:12:32:3	101	215	155	151	159	118	571	563	561	923
263:12:33:3	101	216	156	150	158	117	571	563	561	924
263:12:34:3	101	215	156	150	159	118	571	563	561	925
263:12:35:3	101	216	156	151	159	118	571	563	561	926
263:12:36:3	101	214	155	151	160	118	571	563	561	927
263:12:37:3	102	214	155	151	159	120	570	563	561	929
263:12:38:4	102	216	157	151	158	120	571	563	560	930
263:12:39:3	102	215	158	151	158	119	570	563	561	931
263:12:40:3	102	214	155	152	158	120	571	562	561	932
263:12:41:3	102	214	154	151	159	119	570	562	560	934
263:12:42:3	102	214	154	152	159	120	570	562	560	935
263:12:43:3	102	214	154	153	158	119	570	562	560	935
263:12:44:3	102	216	154	153	160	120	570	562	560	937
263:12:45:3	102	216	156	154	158	121	570	562	560	938
263:12:46:3	102	216	157	154	158	120	570	562	559	939
263:12:47:3	102	216	157	154	158	120	571	562	560	941
263:12:48:3	102	216	156	155	158	120	570	562	560	942
263:12:49:3	102	217	156	156	158	120	569	562	560	943
263:12:50:2	102	216	154	155	159	121	569	562	560	944
263:12:51:3	102	217	156	155	159	121	570	562	560	945
263:12:52:3	102	216	156	156	158	121	570	562	560	946
263:12:53:3	102	216	156	157	158	120	569	561	559	947
263:12:54:3	102	216	156	157	158	121	570	561	559	949
263:12:55:3	102	214	154	157	159	121	570	561	559	949

C-77

DAY 263 1984 DATA.7:00-17:00

TIME DAY:HR:MI:SE	TE180 DEG F	TE181 DEG F	TE211 DEG F	TE231 DEG F	TE286 DEG F	TE387 DEG F	TE281 DEG F	TE282 DEG F	TE283 DEG F	TE291 DEG F
263:12:56:3	102	215	156	157	160	121	570	561	559	950
263:12:57:3	102	216	152	158	159	121	570	561	559	951
263:12:58:3	102	217	152	159	159	121	570	561	558	952
263:12:59:3	102	216	151	157	161	121	569	561	559	952
263:13:0:3	102	213	153	158	161	121	570	561	558	953
263:13:1:2	102	216	154	159	161	121	569	561	558	954
263:13:2:3	102	216	156	157	161	121	569	561	558	954
263:13:3:3	102	214	154	157	161	121	569	561	558	955
263:13:4:3	102	215	154	156	161	121	569	561	558	954
263:13:5:3	102	216	154	157	161	121	569	561	558	955
263:13:6:3	102	214	154	156	162	121	569	561	558	955
263:13:7:3	102	215	156	156	162	121	569	561	558	955
263:13:8:3	102	215	156	156	161	121	569	560	558	956
263:13:9:3	102	216	154	156	161	120	569	560	558	956
263:13:10:3	102	216	155	156	161	121	569	560	558	956
263:13:11:3	103	217	157	156	161	121	569	560	558	957
263:13:12:3	102	217	155	157	161	121	569	560	557	957
263:13:13:3	103	217	155	158	161	122	569	560	558	957
263:13:14:4	103	216	157	156	159	122	569	560	557	958
263:13:15:3	102	216	155	157	160	121	569	559	557	957
263:13:16:3	102	214	155	155	161	121	569	559	557	959
263:13:17:3	102	216	155	156	160	121	569	559	557	959
263:13:18:3	102	215	156	156	161	121	569	559	557	959
263:13:19:3	102	216	156	156	161	121	569	559	557	959
263:13:20:3	102	216	157	156	162	121	569	559	557	958
263:13:21:3	103	217	157	155	161	123	569	559	557	958
263:13:22:3	102	216	157	155	161	121	569	560	557	958
263:13:23:3	103	216	156	154	162	121	569	559	557	957
263:13:24:3	103	217	156	156	162	121	569	560	557	958
263:13:25:4	103	216	156	155	162	122	569	560	556	958
263:13:26:4	103	217	156	154	162	123	569	560	557	959
263:13:27:4	103	216	156	154	162	122	566	559	556	959
263:13:28:3	104	217	156	154	163	123	569	560	557	960
263:13:29:4	103	216	155	153	163	123	569	559	556	960
263:13:30:3	103	217	155	154	163	123	569	559	557	961
263:13:31:4	103	218	154	154	163	122	569	559	556	961
263:13:32:3	103	216	158	154	161	123	569	559	556	961
263:13:33:2	103	218	158	154	161	123	569	559	556	962
263:13:34:2	103	217	158	154	160	123	569	558	556	961
263:13:35:3	103	218	159	154	161	123	569	559	556	962
263:13:36:3	103	217	159	154	159	124	569	559	556	963
263:13:37:2	103	217	160	154	161	124	569	559	556	963
263:13:38:3	102	217	156	155	162	124	569	559	556	964
263:13:39:3	103	215	154	154	163	123	569	558	556	964
263:13:40:2	104	214	156	156	163	123	569	559	556	964
263:13:41:3	104	214	154	154	163	123	569	559	556	964
263:13:42:3	103	216	156	154	162	124	569	559	556	965
263:13:43:3	103	217	157	154	163	123	569	559	556	965
263:13:44:3	104	216	156	155	162	124	569	559	556	965
263:13:45:3	105	216	155	155	163	124	569	558	556	966
263:13:46:3	104	217	156	156	163	124	569	559	556	966
263:13:47:4	104	216	156	154	162	123	569	559	556	966
263:13:48:3	103	216	157	154	163	124	569	559	556	966
263:13:49:2	104	216	156	154	164	124	569	559	556	967
263:13:50:2	104	217	155	154	164	125	569	558	556	967
263:13:51:2	104	217	156	155	164	124	569	558	556	968

C78

TIME DAY:HR:MI:SE	TE180 DEC F	TE181 DEC F	TE211 DEC F	TE231 DEC F	TE286 DEC F	TE387 DEC F	TE281 DEC F	TE282 DEC F	TE283 DEC F	TE291 DEC F
263:13:52: 3	104	217	157	155	164	125	569	558	556	968
263:13:53: 3	104	217	157	154	162	124	569	559	556	968
263:13:54: 3	102	220	154	152	161	125	569	558	556	969
263:13:55: 2	102	218	156	153	162	125	569	558	556	969
263:13:56: 3	103	217	156	154	163	124	569	559	556	969
263:13:57: 2	104	217	156	154	162	125	569	559	556	970
263:13:58: 3	104	216	157	154	162	124	569	559	556	971
263:13:59: 3	104	216	155	154	164	124	569	559	556	971
263:14: 0: 3	104	217	157	153	164	124	569	550	556	972
263:14: 1: 3	103	218	158	154	164	125	569	558	556	972
263:14: 2: 2	103	218	158	153	162	124	569	558	556	972
263:14: 3: 2	103	218	157	153	162	123	569	558	556	972
263:14: 4: 2	103	217	157	153	163	124	569	558	555	972
263:14: 5: 3	103	217	155	154	164	124	569	550	555	973
263:14: 6: 3	105	219	158	154	163	125	569	558	556	973
263:14: 7: 3	105	218	158	154	164	125	569	558	555	974
263:14: 8: 3	105	218	161	154	163	125	569	558	556	974
263:14: 9: 3	105	218	161	154	163	125	569	558	555	975
263:14:10: 2	105	219	161	154	163	125	569	550	556	975
263:14:11: 3	105	219	161	154	162	125	569	550	555	976
263:14:12: 3	105	218	158	155	162	126	569	558	556	976
263:14:13: 3	105	218	158	155	163	126	569	558	555	977
263:14:14: 2	105	217	159	154	162	127	569	558	556	977
263:14:15: 3	106	218	158	154	163	126	569	558	555	977
263:14:16: 2	105	219	159	154	163	126	569	550	555	977
263:14:17: 3	106	218	160	156	162	126	569	558	555	977
263:14:18: 3	105	218	158	155	162	126	569	558	555	977
263:14:19: 3	106	217	159	157	162	126	568	557	555	979
263:14:20: 4	105	216	158	157	163	126	568	557	555	979
263:14:21: 3	105	217	158	155	165	126	568	557	555	979
263:14:22: 2	105	218	158	155	164	126	568	557	555	979
263:14:23: 3	105	218	156	155	165	126	568	558	555	980
263:14:24: 2	106	218	157	156	166	126	569	557	555	980
263:14:25: 2	106	219	160	156	163	126	569	557	555	980
263:14:26: 2	106	219	158	156	162	127	568	558	555	980
263:14:27: 3	106	218	161	156	162	128	569	558	555	981
263:14:28: 3	105	219	161	156	163	126	569	558	555	981
263:14:29: 3	106	218	156	156	165	128	569	550	555	981
263:14:30: 3	106	219	159	156	163	127	569	557	555	981
263:14:31: 2	106	219	161	157	163	128	569	557	555	982
263:14:32: 2	106	219	161	155	162	127	568	557	555	982
263:14:33: 3	106	219	161	155	162	128	569	557	555	982
263:14:34: 3	106	219	161	156	164	128	569	558	555	983
263:14:35: 2	105	219	161	156	163	128	569	550	555	983
263:14:36: 3	105	218	162	154	162	128	569	558	555	983
263:14:37: 2	105	218	157	156	164	128	569	558	555	983
263:14:38: 2	105	217	157	155	165	128	569	558	555	984
263:14:39: 3	106	217	157	154	165	127	569	557	555	984
263:14:40: 3	106	218	218	155	164	128	569	550	555	984
263:14:41: 2	106	220	157	156	164	128	569	550	555	984
263:14:42: 2	106	218	156	156	165	128	569	557	555	985
263:14:43: 3	106	217	156	157	165	128	569	558	555	985
263:14:44: 3	106	218	156	156	164	127	568	558	555	985
263:14:45: 4	106	217	156	155	164	126	569	557	555	985
263:14:46: 3	106	218	158	154	164	126	568	557	555	985
263:14:47: 3	105	219	158	155	164	126	568	558	555	986

C79

## DAY 263 1984 DATA.7:00-17:00

TIME DAY:HR:MI:SE	TE180 DEG F	TE181 DEG F	TE211 DEG F	TE231 DEG F	TE286 DEG F	TE387 DEG F	TE281 DEG F	TE282 DEG F	TE283 DEG F	TE291 DEG F
263:14:48: 3	106	220	157	155	164	126	569	557	555	986
263:14:49: 2	105	220	159	155	164	126	569	558	555	986
263:14:50: 3	105	219	159	154	165	126	568	557	555	986
263:14:51: 3	106	219	160	156	165	128	569	558	555	987
263:14:52: 2	106	218	158	154	166	128	569	558	556	987
263:14:53: 3	106	218	159	155	165	127	568	557	555	987
263:14:54: 2	106	220	161	156	166	128	569	558	555	988
263:14:55: 3	106	218	159	154	165	126	568	557	555	987
263:14:56: 3	106	219	158	154	165	126	568	558	555	988
263:14:57: 2	106	218	159	154	165	128	568	557	555	988
263:14:58: 3	106	219	159	156	165	128	568	557	555	988
263:14:59: 3	107	218	157	157	166	128	569	558	555	989
263:15: 0: 3	107	220	157	157	165	128	568	557	555	989
263:15: 1: 2	107	218	156	158	165	128	568	557	555	989
263:15: 2: 2	107	220	158	158	165	128	568	557	555	988
263:15: 3: 2	107	219	157	158	166	128	568	557	555	986
263:15: 4: 2	108	219	157	159	166	128	569	558	555	986
263:15: 5: 3	107	220	158	157	167	128	569	558	555	985
263:15: 6: 3	107	221	158	158	166	128	569	558	555	983
263:15: 7: 3	107	218	157	157	165	128	568	557	555	982
263:15: 8: 3	106	219	158	156	165	128	568	557	555	980
263:15: 9: 3	106	218	158	157	165	128	568	557	555	979
263:15:10: 2	107	220	159	157	166	128	568	557	555	979
263:15:11: 3	106	218	158	157	165	128	567	557	555	977
263:15:12: 3	106	220	157	157	165	127	568	557	554	976
C80 263:15:13: 2	106	220	161	158	164	128	568	557	555	975
263:15:14: 2	106	219	159	158	165	128	568	557	554	974
263:15:15: 3	106	218	158	157	165	128	567	557	555	973
263:15:16: 3	106	218	159	156	166	128	567	557	555	972
263:15:17: 2	106	218	159	155	166	128	567	557	555	972
263:15:18: 3	107	217	161	154	165	128	567	557	554	971
263:15:19: 2	107	218	161	156	166	129	568	557	555	971
263:15:20: 2	106	218	162	156	165	129	566	556	554	970
263:15:21: 2	106	220	163	158	165	129	568	557	555	971
263:15:22: 2	107	220	162	156	165	129	567	557	555	970
263:15:23: 3	106	218	158	155	166	129	566	556	554	969
263:15:24: 2	107	220	159	156	166	129	567	555	554	970
263:15:25: 2	107	220	162	154	165	131	567	557	554	969
263:15:26: 3	107	220	162	155	164	130	567	557	554	970
263:15:27: 2	107	217	160	154	165	128	566	556	554	970
263:15:28: 2	107	219	161	154	165	129	566	557	554	970
263:15:29: 2	107	220	160	155	166	129	566	557	554	971
263:15:30: 2	106	220	160	157	166	128	566	557	554	971
263:15:31: 2	106	220	161	155	166	129	566	557	554	971
263:15:32: 2	107	220	162	156	167	130	567	557	555	971
263:15:33: 3	108	219	162	154	166	129	566	557	554	971
263:15:34: 2	108	220	162	155	166	131	566	556	554	972
263:15:35: 3	106	219	160	156	165	131	565	556	554	972
263:15:36: 2	106	218	158	155	166	128	565	556	553	971
263:15:37: 3	107	217	159	154	167	128	566	556	554	972
263:15:38: 3	106	219	159	156	166	129	566	556	553	972
263:15:39: 2	107	219	159	156	166	130	565	556	554	972
263:15:40: 2	107	220	158	156	166	129	566	556	553	972
263:15:41: 2	107	218	159	155	166	130	566	556	553	973
263:15:42: 2	106	219	159	154	166	129	566	556	554	972
263:15:43: 2	106	219	159	156	165	128	566	556	554	973



DAY 263 1984 DATA.7:00-17:00

TIME DAY:HR:MI:SE	TE180 DEC F	TE181 DEC F	TE211 DEC F	TE231 DEC F	TE286 DEC F	TE387 DEC F	TE281 DEC F	TE282 DEC F	TE283 DEC F	TE291 DEC F
263:15:44: 3	106	219	159	156	164	128	566	556	553	973
263:15:45: 3	106	218	159	156	165	128	566	556	553	974
263:15:46: 2	106	218	159	156	165	128	566	556	553	975
263:15:47: 3	106	218	158	154	165	128	566	556	553	974
263:15:48: 2	106	217	158	154	165	128	566	556	553	975
263:15:49: 3	106	217	161	156	165	128	566	556	553	974
263:15:50: 3	107	217	160	154	166	128	566	555	553	975
263:15:51: 2	107	219	161	154	166	129	566	556	553	975
263:15:52: 2	107	218	164	154	165	131	566	556	553	975
263:15:53: 3	107	218	162	154	166	130	566	556	553	975
263:15:54: 2	107	217	161	152	166	129	566	555	553	975
263:15:55: 2	107	191	163	150	166	129	566	555	553	975
263:15:56: 3	107	217	161	150	166	128	566	555	553	975
263:15:57: 2	107	218	161	149	167	128	566	555	553	975
263:15:58: 3	107	216	160	148	167	129	566	556	553	976
263:15:59: 3	106	217	159	147	166	129	566	555	553	976
263:16: 0: 4	106	217	160	145	167	129	566	555	553	976
263:16: 1: 2	106	217	161	144	166	128	566	556	554	977
263:16: 2: 3	106	217	161	142	166	129	566	555	553	976
263:16: 3: 3	106	217	161	141	166	128	566	555	553	976
263:16: 4: 3	106	216	159	139	166	128	566	555	553	976
263:16: 5: 3	106	217	159	138	167	128	566	555	553	977
263:16: 6: 3	106	216	158	136	167	128	566	555	553	977
263:16: 7: 2	107	217	158	136	166	128	566	555	553	977
263:16: 8: 2	106	217	160	135	166	128	566	555	553	977
263:16: 9: 3	106	217	162	133	167	128	566	555	553	977
263:16:10: 2	107	217	162	132	168	128	566	555	553	977
263:16:11: 3	107	217	161	131	166	128	566	555	553	977
263:16:12: 3	107	217	160	130	166	127	566	555	553	977
263:16:13: 2	107	218	160	130	165	128	571	602	553	974
263:16:14: 2	107	217	161	129	166	129	566	590	553	975
263:16:15: 2	107	217	160	128	166	128	567	584	554	973
263:16:16: 3	108	217	158	128	167	128	569	578	554	974
263:16:17: 3	107	215	156	126	167	128	569	572	554	973
263:16:18: 3	107	216	159	125	165	128	568	569	554	973
263:16:19: 3	107	216	162	125	166	128	569	566	554	973
263:16:20: 2	106	220	161	124	162	126	569	575	555	973
263:16:21: 3	106	228	162	124	159	128	570	576	556	973
263:16:22: 2	106	232	168	123	157	128	571	572	556	973
263:16:23: 2	107	241	169	122	156	128	570	574	556	973
263:16:24: 3	107	246	169	122	154	128	570	570	556	973
263:16:25: 2	107	248	170	121	155	128	570	567	555	973
263:16:26: 3	107	251	169	121	156	127	570	565	556	973
263:16:27: 3	107	255	168	121	154	127	570	563	555	973
263:16:28: 2	106	264	166	120	154	126	570	562	555	973
263:16:29: 3	107	267	166	120	154	126	570	561	555	973
263:16:30: 3	106	273	164	119	153	125	570	560	555	973
263:16:31: 2	106	276	161	118	153	125	570	560	555	972
263:16:32: 3	107	285	161	118	152	126	570	560	555	973
263:16:33: 3	107	286	159	118	151	127	571	558	555	973
263:16:34: 4	107	290	159	117	152	126	570	558	555	972
263:16:35: 2	106	294	158	118	152	125	571	558	555	972
263:16:36: 2	106	299	158	117	153	125	570	558	555	972
263:16:37: 3	106	299	158	117	153	125	571	558	555	973
263:16:38: 2	107	301	157	117	154	125	571	558	555	972
263:16:39: 2	106	304	158	117	154	125	571	558	555	972

CG1

DAY 263 1984 DATA.7:00-17:00

TIME DAY:HR:MI:SE	TE292 DEG F	TE293 DEG F	PT382 PSI	PT383 PSI	PT384 PSI	PT386 PSIO	LT311 .011NCH	FT311 10 LB/HR	FT321 100LB/HR	FT381 LB/HR
263:12:0:4	859	852	64	1032	41	0	-5	512	451	0
263:12:1:3	858	852	66	1035	41	0	-24	455	442	0
263:12:2:4	858	852	69	1029	41	0	0	527	460	0
263:12:3:3	858	851	67	1024	41	0	1	484	435	0
263:12:4:3	857	851	65	1029	41	0	-15	401	449	0
263:12:5:3	857	851	63	1034	41	0	-9	486	458	0
263:12:6:3	857	851	65	1026	41	0	-15	474	440	0
263:12:7:3	856	850	64	1028	41	0	-10	490	459	0
263:12:8:3	856	850	65	1034	41	0	1	505	445	0
263:12:9:3	857	851	67	1029	41	0	0	500	446	0
263:12:10:3	857	851	65	1026	40	0	7	510	454	0
263:12:11:4	856	850	64	1018	41	0	7	545	449	0
263:12:12:3	856	851	64	1033	40	0	58	552	462	0
263:12:13:3	856	850	64	1028	41	0	1	516	448	0
263:12:14:3	857	850	64	1020	41	0	17	479	445	0
263:12:15:3	858	850	63	1022	41	0	-15	461	454	0
263:12:16:3	858	851	64	1024	41	0	7	504	442	0
263:12:17:3	859	851	68	1024	41	0	22	537	460	0
263:12:18:3	860	851	77	1020	41	0	12	496	444	0
263:12:19:3	860	852	75	1020	41	0	-4	490	446	0
263:12:20:3	861	852	53	1062	32	0	-34	805	734	0
263:12:21:3	862	853	50	1159	25	0	12	672	722	0
263:12:22:3	863	854	57	1130	26	0	22	656	578	0
263:12:23:3	865	855	55	1128	28	0	0	678	600	0
263:12:24:3	866	856	57	1128	28	0	-10	676	607	0
263:12:25:3	867	857	48	1137	25	0	-15	750	683	0
263:12:26:3	868	858	50	1130	23	0	1	799	695	0
263:12:27:3	869	859	51	1126	22	0	17	762	665	0
263:12:28:3	870	859	51	1132	22	0	12	795	674	0
263:12:29:4	871	861	52	1133	21	0	23	799	684	0
263:12:30:3	871	861	54	1137	21	0	1	772	657	0
263:12:31:3	872	862	52	1128	21	0	-18	776	664	0
263:12:32:3	873	863	52	1136	21	0	-10	701	662	0
263:12:33:3	874	864	54	1134	22	0	-15	754	623	0
263:12:34:3	876	865	52	1130	23	0	-5	766	663	0
263:12:35:3	877	866	60	1122	25	0	0	670	571	0
263:12:36:3	878	867	59	1124	20	0	17	672	587	0
263:12:37:3	878	867	60	1124	29	0	-15	636	557	0
263:12:38:4	879	869	60	1121	31	0	22	650	547	0
263:12:39:3	881	870	69	1119	32	0	17	647	555	0
263:12:40:3	883	871	63	1126	32	0	-15	623	537	0
263:12:41:3	884	872	65	1120	32	0	11	660	554	0
263:12:42:3	885	874	62	1122	33	0	-10	660	554	0
263:12:43:3	886	874	59	1126	32	0	-10	647	563	0
263:12:44:3	888	876	59	1124	32	0	17	668	575	0
263:12:45:3	889	877	63	1121	32	0	-10	664	540	0
263:12:46:3	890	878	63	1128	32	0	-14	634	547	0
263:12:47:3	892	880	63	1126	32	0	7	650	554	0
263:12:48:3	893	881	50	1126	32	0	-5	726	602	0
263:12:49:3	894	882	55	1134	20	0	7	768	635	0
263:12:50:2	895	883	56	1134	27	0	-10	803	640	0
263:12:51:3	897	885	57	1140	26	0	7	787	632	0
263:12:52:3	898	885	60	1134	26	0	-15	760	605	0
263:12:53:3	898	887	59	1128	27	0	7	727	594	0
263:12:54:3	899	888	62	1120	29	0	7	672	546	0
263:12:55:3	901	889	60	1126	30	0	-15	664	565	0

C82

TIME DAY:HR:MI:SE	TE292 DEC F	TE293 DEC F	PT382 PSI	PT383 PSI	PT384 PSI	PT386 PSIO	LT311 .011NCH	FT311 10 LB/HR	FT321 100LB/HR	FT381 LB/HR
263:12:56: 3	902	890	61	1124	31	0	12	662	547	0
263:12:57: 3	903	891	59	1128	31	0	-15	705	596	0
263:12:58: 3	904	892	60	1134	29	0	-19	741	606	0
263:12:59: 3	904	893	49	1102	29	0	119	1010	708	0
263:13: 0: 3	905	894	49	1106	24	0	17	1026	730	0
263:13: 1: 2	906	895	49	1072	19	0	7	1079	720	0
263:13: 2: 3	905	894	50	1046	17	0	1	1100	681	0
263:13: 3: 3	906	895	49	1028	16	0	-15	1061	724	0
263:13: 4: 3	906	895	49	1016	15	0	-5	1053	728	0
263:13: 5: 3	906	895	52	1026	14	0	-10	1043	725	0
263:13: 6: 3	907	896	50	1111	14	0	-10	854	729	0
263:13: 7: 3	907	897	51	1182	13	0	-5	834	715	0
263:13: 8: 3	908	898	56	1134	17	0	1	840	672	0
263:13: 9: 3	908	898	51	1144	17	0	1	897	696	0
263:13:10: 3	909	898	59	1130	19	0	1	840	650	0
263:13:11: 3	909	898	65	1140	20	0	0	883	674	0
263:13:12: 3	909	898	57	1143	20	0	-5	926	692	0
263:13:13: 3	909	899	55	1143	18	0	-15	932	705	0
263:13:14: 4	910	899	52	1141	17	0	-5	938	725	0
263:13:15: 3	911	900	51	1141	17	0	0	938	719	0
263:13:16: 3	911	901	50	1143	16	0	0	949	724	0
263:13:17: 3	910	900	51	1147	16	0	-10	938	717	0
263:13:18: 3	909	900	52	1140	15	0	1	930	693	0
263:13:19: 3	909	900	50	1141	15	0	-5	940	709	0
263:13:20: 3	909	899	59	1141	15	0	0	940	713	0
263:13:21: 3	909	899	57	1143	16	0	-10	945	717	0
263:13:22: 3	909	899	52	1143	16	0	-15	942	720	0
263:13:23: 3	909	899	50	1141	15	0	-10	942	719	0
263:13:24: 3	910	901	51	1143	15	0	-10	936	708	0
263:13:25: 4	911	901	52	1140	16	0	-5	936	708	0
263:13:26: 4	912	902	53	1142	16	0	7	935	705	0
263:13:27: 4	913	903	52	1143	16	0	0	932	705	0
263:13:28: 3	914	904	49	1140	15	0	-5	956	721	0
263:13:29: 4	914	904	51	1147	15	0	-10	969	730	0
263:13:30: 3	914	904	51	1147	15	0	0	963	719	0
263:13:31: 4	915	905	52	1141	15	0	-5	954	724	0
263:13:32: 3	915	905	61	1134	16	0	1	952	719	0
263:13:33: 2	915	906	53	1141	15	0	12	980	732	0
263:13:34: 2	915	906	55	1146	15	0	1	940	704	0
263:13:35: 3	917	906	57	1142	15	0	-5	993	734	0
263:13:36: 3	917	907	56	1157	15	0	0	946	723	0
263:13:37: 2	917	907	55	1136	16	0	-15	915	677	0
263:13:38: 3	917	907	58	1126	18	0	-10	836	632	0
263:13:39: 3	917	908	62	1122	22	0	12	754	574	0
263:13:40: 2	918	908	57	1122	25	0	17	815	660	0
263:13:41: 3	918	908	50	1122	22	0	1	1094	733	0
263:13:42: 3	919	909	49	1084	18	0	2	1060	731	0
263:13:43: 3	919	909	52	1107	17	0	-10	1001	737	0
263:13:44: 3	919	910	56	1132	16	0	-5	997	734	0
263:13:45: 3	920	911	52	1134	14	0	-5	1003	746	0
263:13:46: 3	920	911	51	1122	14	0	7	1004	739	0
263:13:47: 4	921	911	50	1124	13	0	-5	996	737	0
263:13:48: 3	922	912	50	1138	13	0	-15	989	736	0
263:13:49: 2	922	912	49	1153	14	0	-5	977	728	0
263:13:50: 2	923	913	50	1163	13	0	0	985	738	0
263:13:51: 2	923	913	50	1167	12	0	-15	984	733	0

C83

DAY 263 1984 DATA.7:00-17:00

TIME DAY:HR:MI:SE	TE292 DEC F	TE293 DEC F	PT382 PSI	PT383 PSI	PT384 PSI	PT386 PSIO	LT311 .01INCH	FT311 10 LB/HR	FT321 100LB/HR	FT381 LB/HR
263:13:52: 3	924	915	54	1145	14	0	12	973	706	0
263:13:53: 3	924	915	51	1143	14	0	-5	987	720	0
263:13:54: 3	925	916	51	1143	14	0	1	1012	734	0
263:13:55: 2	925	916	50	1143	14	0	1	1014	741	0
263:13:56: 3	926	917	52	1137	13	0	-10	1049	745	0
263:13:57: 2	927	917	51	1128	13	0	1	1043	732	0
263:13:58: 3	927	917	50	1122	13	0	1	1038	737	0
263:13:59: 3	927	918	50	1121	13	0	1	1049	739	0
263:14: 0: 3	927	918	50	1119	13	0	-9	1033	724	0
263:14: 1: 3	928	919	50	1119	12	0	7	1038	739	0
263:14: 2: 2	929	919	50	1111	12	0	0	1065	739	0
263:14: 3: 2	928	919	50	1107	13	0	-3	1065	737	0
263:14: 4: 2	929	919	49	1104	13	0	-5	1073	745	0
263:14: 5: 3	929	920	50	1100	13	0	0	1061	734	0
263:14: 6: 3	929	920	50	1104	12	0	7	1061	739	0
263:14: 7: 3	929	920	50	1103	12	0	1	1073	739	0
263:14: 8: 3	930	920	51	1107	12	0	-5	1069	737	0
263:14: 9: 3	930	921	51	1103	12	0	-5	1067	730	0
263:14:10: 2	930	921	53	1100	13	0	0	1065	737	0
263:14:11: 3	931	922	56	1100	12	0	-10	1065	734	0
263:14:12: 3	931	922	52	1102	12	0	-10	1073	738	0
263:14:13: 3	931	923	51	1104	13	0	0	1061	727	0
263:14:14: 2	932	923	52	1107	13	0	-5	1073	739	0
263:14:15: 3	932	923	55	1107	13	0	-5	1069	739	0
263:14:16: 2	932	924	52	1109	13	0	-5	1078	743	0
263:14:17: 3	933	924	51	1109	13	0	-5	1071	736	0
263:14:18: 3	933	924	51	1111	13	0	7	1063	743	0
263:14:19: 3	934	925	52	1111	13	0	-4	1078	745	0
263:14:20: 4	934	925	52	1111	13	0	-10	1078	745	0
263:14:21: 3	934	925	51	1111	13	0	-5	1075	748	0
263:14:22: 2	933	925	51	1115	12	0	-10	1082	757	0
263:14:23: 3	934	925	51	1115	13	0	0	1059	736	0
263:14:24: 2	934	925	51	1119	13	0	1	1067	747	0
263:14:25: 2	934	926	56	1119	13	0	-5	1055	750	0
263:14:26: 2	934	926	54	1121	13	0	-5	1067	756	0
263:14:27: 3	935	926	58	1121	13	0	1	1066	753	0
263:14:28: 3	935	927	56	1121	13	0	-5	1073	753	0
263:14:29: 3	935	927	53	1121	13	0	-5	1075	762	0
263:14:30: 3	935	927	53	1119	13	0	-5	1063	743	0
263:14:31: 2	936	928	52	1115	12	0	1	1071	749	0
263:14:32: 2	936	928	54	1117	13	0	1	1067	747	0
263:14:33: 3	935	928	57	1117	13	0	-5	1071	751	0
263:14:34: 3	936	928	58	1117	13	0	-10	1082	753	0
263:14:35: 2	936	929	60	1117	13	0	-10	1067	753	0
263:14:36: 3	936	928	55	1122	13	0	-5	1069	755	0
263:14:37: 2	936	929	52	1107	13	0	-5	1106	755	0
263:14:38: 2	937	929	52	1095	13	0	-5	1116	751	0
263:14:39: 3	936	929	52	1091	13	0	0	1106	755	0
263:14:40: 3	937	929	52	1090	13	0	-5	1111	754	0
263:14:41: 2	937	929	52	1088	13	0	0	1113	753	0
263:14:42: 2	937	930	52	1086	13	0	-5	1106	756	0
263:14:43: 3	937	930	52	1086	12	0	-5	1111	757	0
263:14:44: 3	937	930	53	1086	13	0	0	1111	753	0
263:14:45: 4	938	930	53	1091	13	0	-4	1116	752	0
263:14:46: 3	938	931	52	1091	13	0	0	1114	756	0
263:14:47: 3	938	931	52	1091	12	0	-5	1118	747	0

C84

DAY 263 1984 DATA.7:00-17:00

TIME	TE292	TE293	PT382	PT383	PT384	PT386	LT311	FT311	FT321	FT381
DAY:HR:MI:SE	DEG F	DEG F	PSI	PSI	PSI	PSIO	.01INCH	10 LB/HR	100LB/HR	LB/HR
263:14:48: 3	939	931	52	1091	13	0	-5	1104	762	0
263:14:49: 2	939	931	52	1093	13	0	0	1116	743	0
263:14:50: 3	939	931	52	1095	13	0	7	1113	752	0
263:14:51: 3	940	932	52	1089	13	0	-5	1111	759	0
263:14:52: 2	940	933	53	1091	13	0	-5	1111	759	0
263:14:53: 3	940	933	55	1093	12	0	0	1099	760	0
263:14:54: 2	941	933	54	1095	13	0	0	1102	757	0
263:14:55: 3	940	932	53	1095	13	0	0	1106	756	0
263:14:56: 3	940	933	54	1100	13	0	-10	1096	766	0
263:14:57: 2	940	933	55	1095	13	0	1	1111	755	0
263:14:58: 3	940	933	53	1091	13	0	0	1113	761	0
263:14:59: 3	941	934	54	1086	13	0	0	1132	764	0
263:15: 0: 3	941	934	57	1079	13	0	-10	1131	765	0
263:15: 1: 2	939	933	63	1068	13	0	-5	1141	765	0
263:15: 2: 2	937	931	62	1062	14	0	-5	1139	765	0
263:15: 3: 2	937	931	60	1057	13	0	0	1132	761	0
263:15: 4: 2	937	930	58	1047	13	0	-10	1131	761	0
263:15: 5: 3	936	930	53	1044	13	0	1	1137	759	0
263:15: 6: 3	936	929	53	1042	13	0	7	1141	759	0
263:15: 7: 3	935	927	52	1038	13	0	-5	1129	759	0
263:15: 8: 3	933	926	51	1038	13	0	0	1124	756	0
263:15: 9: 3	932	925	51	1038	12	0	1	1121	755	0
263:15:10: 2	931	925	51	1038	13	0	-5	1122	757	0
263:15:11: 3	931	924	51	1045	13	0	-5	1116	759	0
263:15:12: 3	930	923	51	1044	13	0	1	1110	740	0
263:15:13: 2	930	923	57	1046	13	0	1	1119	751	0
263:15:14: 2	929	922	52	1045	13	0	-5	1100	745	0
263:15:15: 3	929	922	51	1044	12	0	-10	1118	752	0
263:15:16: 3	927	921	51	1045	13	0	-5	1110	753	0
263:15:17: 2	927	921	52	1047	13	0	-5	1108	765	0
263:15:18: 3	927	921	64	1044	12	0	1	1104	760	0
263:15:19: 2	928	921	57	1047	13	0	-5	1108	756	0
263:15:20: 2	927	920	56	1047	13	0	0	1106	755	0
263:15:21: 2	929	921	52	1044	13	0	-5	1102	753	0
263:15:22: 2	929	921	52	1047	12	0	0	1099	757	0
263:15:23: 3	929	921	51	1053	13	0	1	1096	757	0
263:15:24: 2	929	922	52	1053	13	0	-5	1102	760	0
263:15:25: 2	929	921	54	1057	13	0	-5	1096	746	0
263:15:26: 3	929	922	53	1057	13	0	-5	1106	757	0
263:15:27: 2	929	922	54	1055	13	0	-5	1106	747	0
263:15:28: 2	930	923	52	1055	13	0	-10	1100	755	0
263:15:29: 2	930	922	51	1055	12	0	-10	1116	756	0
263:15:30: 2	929	922	50	1051	13	0	-10	1129	757	0
263:15:31: 2	930	923	51	1053	13	0	-5	1124	759	0
263:15:32: 2	930	923	53	1053	12	0	0	1110	755	0
263:15:33: 3	930	923	64	1057	13	0	-5	1104	762	0
263:15:34: 2	930	923	58	1062	13	0	-5	1098	760	0
263:15:35: 3	930	923	54	1066	13	0	-5	1079	750	0
263:15:36: 2	929	923	52	1102	13	0	-10	1014	751	0
263:15:37: 3	930	923	51	1147	12	0	0	987	749	0
263:15:38: 3	930	923	60	1184	13	0	0	965	742	0
263:15:39: 2	930	923	63	1142	16	0	-10	920	687	0
263:15:40: 2	930	923	59	1139	18	0	1	885	667	0
263:15:41: 2	930	924	62	1138	21	0	1	862	655	0
263:15:42: 2	930	923	74	1121	28	0	57	531	380	0
263:15:43: 2	930	924	73	1109	36	0	1	502	398	0

C85

DAY 263 1984 DATA.7:00-17:00

TIME DAY:HR:MI:SE	TE292 DEG F	TE293 DEG F	PT382 PSI	PT383 PSI	PT384 PSI	PT386 PSI0	LT311 .011NCH	FT311 10 LB/HR	FT321 100LB/HR	FT381 LB/HR
263:15:44: 3	931	924	73	1111	40	0	-5	479	386	0
263:15:45: 3	931	925	79	1109	46	0	-30	439	314	0
263:15:46: 2	931	925	75	1100	48	0	22	390	303	0
263:15:47: 3	931	925	75	1095	48	0	17	400	307	0
263:15:48: 2	932	926	75	1095	49	0	-5	373	300	0
263:15:49: 3	931	926	75	1100	50	0	-15	377	304	0
263:15:50: 3	933	926	75	1095	50	0	7	410	304	0
263:15:51: 2	933	927	26	1074	45	0	12	226	134	0
263:15:52: 2	933	927	25	1062	38	0	1	79	118	0
263:15:53: 3	934	928	26	1086	34	0	-5	25	126	0
263:15:54: 2	934	928	26	1086	31	0	-14	113	118	0
263:15:55: 2	934	929	24	1097	26	0	7	230	165	0
263:15:56: 3	934	929	23	1090	23	0	-19	287	266	0
263:15:57: 2	935	929	23	1084	20	0	-15	221	286	0
263:15:58: 3	935	930	19	1078	18	0	-5	154	269	0
263:15:59: 3	936	931	18	1072	16	0	-30	132	271	0
263:16: 0: 4	936	931	14	1066	14	0	1	74	228	0
263:16: 1: 2	937	931	13	1045	13	0	57	25	209	0
263:16: 2: 3	937	931	10	1028	11	0	100	1	173	0
263:16: 3: 3	937	932	9	1011	10	0	139	1	166	0
263:16: 4: 3	938	933	8	995	9	0	159	1	166	0
263:16: 5: 3	938	933	7	984	8	0	212	1	168	0
263:16: 6: 3	939	934	7	1011	7	0	253	1	167	0
263:16: 7: 2	940	934	8	1042	7	0	186	1	161	0
263:16: 8: 2	940	935	7	1055	6	0	164	1	170	0
263:16: 9: 3	940	935	6	1067	6	0	145	1	170	0
263:16:10: 2	941	936	6	1076	5	0	119	1	171	0
263:16:11: 3	941	936	6	1078	5	0	89	1	170	0
263:16:12: 3	940	935	5	1078	5	0	41	1	163	0
263:16:13: 2	938	933	5	1076	4	0	-5	1	172	0
263:16:14: 2	936	930	4	1074	4	0	-56	1	168	0
263:16:15: 2	936	929	4	1074	4	0	63	1	170	0
263:16:16: 3	936	929	4	1070	3	0	27	1	167	0
263:16:17: 3	935	927	5	1047	4	0	154	1	162	0
263:16:18: 3	934	926	4	1007	3	0	236	1	173	0
263:16:19: 3	935	927	3	974	4	0	175	1	131	0
263:16:20: 2	935	926	3	930	3	0	154	1	54	0
263:16:21: 3	935	926	2	897	3	0	303	1	30	0
263:16:22: 2	935	927	1	865	2	0	498	1	40	0
263:16:23: 2	935	927	1	845	2	0	876	1	26	0
263:16:24: 3	935	926	1	855	2	0	983	1	36	0
263:16:25: 2	936	927	1	873	1	0	1148	1	36	0
263:16:26: 3	936	927	1	854	2	0	754	1	36	0
263:16:27: 3	936	927	1	876	1	0	830	1	30	0
263:16:28: 2	936	927	1	851	2	0	759	1	40	0
263:16:29: 3	937	929	1	928	1	0	1368	1	36	0
263:16:30: 3	936	927	1	965	1	0	1809	1	52	0
263:16:31: 2	936	927	2	957	1	0	1951	1	55	0
263:16:32: 3	936	927	2	934	0	0	1973	1	36	0
263:16:33: 3	936	928	2	917	0	0	1989	1	36	0
263:16:34: 4	936	927	1	899	0	0	1992	1	40	0
263:16:35: 2	937	928	1	884	0	0	2002	1	40	0
263:16:36: 2	937	928	1	871	0	0	2002	1	52	0
263:16:37: 3	937	929	1	861	1	0	2007	1	40	0
263:16:38: 2	937	929	1	845	0	0	2013	1	34	0
263:16:39: 2	937	929	0	838	1	0	2013	1	34	0

C-86

TIME DAY:HR:MI:SE	FT382 10 L.B/HR	FT411 10 L.B/HR	TE301 DEC F	TE331 DEC F	TE332 DEC F	TE382 DEC F	TE383 DEC F	TE384 DEC F	TE386 DEC F	TE388 DEC F
263:12:0:4	372	534	801	884	874	900	549	552	532	542
263:12:1:3	395	587	803	884	874	900	549	551	526	542
263:12:2:4	389	548	803	884	872	900	549	551	517	543
263:12:3:3	387	445	800	884	873	900	549	551	508	544
263:12:4:3	374	505	801	885	874	900	549	549	502	542
263:12:5:3	399	583	808	885	874	900	549	549	503	541
263:12:6:3	389	489	801	884	874	899	548	551	507	541
263:12:7:3	376	482	803	885	874	899	548	551	514	541
263:12:8:3	391	520	803	884	874	900	549	551	519	541
263:12:9:3	399	503	801	884	874	900	549	551	519	541
263:12:10:3	380	495	801	884	874	900	549	551	517	541
263:12:11:4	378	493	801	884	874	900	548	551	514	542
263:12:12:3	403	347	806	885	874	900	551	551	511	542
263:12:13:3	391	564	803	884	874	900	549	551	509	542
263:12:14:3	393	419	801	882	872	897	548	551	511	542
263:12:15:3	401	475	800	881	872	897	547	551	512	541
263:12:16:3	395	437	803	882	872	898	549	551	514	542
263:12:17:3	399	425	800	882	872	898	548	551	515	541
263:12:18:3	397	464	801	884	873	900	549	551	516	541
263:12:19:3	395	497	803	886	873	901	549	551	515	542
263:12:20:3	405	1058	811	884	877	904	554	555	514	542
263:12:21:3	409	660	821	889	881	908	564	558	514	544
263:12:22:3	387	505	806	888	879	909	561	562	514	544
263:12:23:3	404	749	811	891	882	911	561	562	515	547
263:12:24:3	397	757	811	893	884	912	560	562	515	548
263:12:25:3	401	792	821	894	886	915	561	561	510	548
263:12:26:3	397	814	815	894	888	916	561	563	509	548
263:12:27:3	378	618	814	896	888	918	561	563	517	548
263:12:28:3	401	796	818	897	889	918	561	563	522	550
263:12:29:4	393	705	818	897	891	919	562	565	520	550
263:12:30:3	409	775	820	899	893	921	562	564	514	551
263:12:31:3	378	877	815	900	893	922	561	563	509	548
263:12:32:3	397	884	821	902	894	922	562	563	511	551
263:12:33:3	409	861	821	902	894	924	561	563	515	548
263:12:34:3	405	802	821	903	896	924	561	563	518	548
263:12:35:3	403	681	817	903	893	925	560	563	520	550
263:12:36:3	395	587	818	905	894	927	560	563	520	550
263:12:37:3	393	753	824	906	896	927	560	563	519	550
263:12:38:4	403	587	820	908	897	928	560	561	517	550
263:12:39:3	389	644	818	910	900	930	560	561	516	551
263:12:40:3	409	679	824	911	900	932	561	562	516	551
263:12:41:3	397	609	821	911	903	933	560	561	518	548
263:12:42:3	382	749	824	913	902	935	560	561	520	550
263:12:43:3	389	689	823	914	905	935	560	561	520	550
263:12:44:3	380	587	824	916	907	936	560	561	518	551
263:12:45:3	401	738	824	916	907	938	560	562	515	550
263:12:46:3	401	704	826	918	910	940	560	562	513	552
263:12:47:3	395	616	827	919	910	940	560	562	514	550
263:12:48:3	405	709	827	920	911	941	560	561	516	550
263:12:49:3	395	658	829	920	912	944	561	563	518	550
263:12:50:2	399	861	832	922	914	944	562	563	518	550
263:12:51:3	395	720	832	922	916	946	561	563	518	550
263:12:52:3	380	828	831	923	916	946	561	563	517	550
263:12:53:3	395	765	829	923	916	947	561	563	514	550
263:12:54:3	399	644	829	925	917	947	560	561	510	550
263:12:55:3	384	728	834	928	917	949	560	561	510	550

C87

DAY 263 1984 DATA.7:00-17:00

TIME DAY:HR:MI:SE	FT382 10 LB/HR	FT411 10 LB/HR	TE301 DEG F	TE331 DEG F	TE332 DEG F	TE382 DEG F	TE383 DEB F	TE384 DEG F	TE386 DEG F	TE388 DEG F
263:12:56: 3	387	618	838	928	917	950	560	561	513	548
263:12:57: 3	403	691	837	928	920	950	561	562	517	548
263:12:58: 3	387	867	837	928	922	952	561	563	522	551
263:12:59: 3	411	590	836	926	922	952	558	563	525	550
263:13: 0: 3	391	1019	834	926	922	953	558	563	524	550
263:13: 1: 2	399	1110	832	925	920	953	554	563	518	550
263:13: 2: 3	413	1128	832	925	920	953	552	558	510	549
263:13: 3: 3	393	1170	832	925	920	952	549	555	504	545
263:13: 4: 3	415	816	834	925	920	953	547	554	502	542
263:13: 5: 3	403	1105	837	926	920	952	548	554	505	541
263:13: 6: 3	415	789	849	931	923	953	556	555	509	539
263:13: 7: 3	413	834	849	931	922	953	566	561	513	541
263:13: 8: 3	417	709	838	928	922	953	562	564	516	545
263:13: 9: 3	394	904	836	928	923	953	563	565	520	547
263:13:10: 3	393	777	838	928	920	953	562	565	529	550
263:13:11: 3	417	884	837	930	922	953	562	566	539	550
263:13:12: 3	404	876	836	928	922	955	562	566	538	552
263:13:13: 3	409	1044	836	928	922	955	562	566	524	553
263:13:14: 4	411	952	841	930	923	955	562	565	510	553
263:13:15: 3	391	964	838	930	923	957	563	565	506	550
263:13:16: 3	389	900	843	931	924	957	563	565	509	550
263:13:17: 3	415	982	843	931	924	958	563	564	516	548
263:13:18: 3	399	919	838	931	925	957	563	566	521	550
263:13:19: 3	391	919	837	930	925	954	562	566	523	548
263:13:20: 3	409	847	841	928	923	955	562	566	522	550
263:13:21: 3	399	929	840	928	923	955	562	566	520	550
263:13:22: 3	415	955	841	928	923	955	562	566	518	550
263:13:23: 3	413	964	838	928	923	955	562	566	517	551
263:13:24: 3	415	986	838	930	923	955	562	566	517	550
263:13:25: 4	401	919	838	930	923	955	562	566	518	550
263:13:26: 4	403	908	838	930	923	957	562	566	519	552
263:13:27: 4	405	828	841	931	923	957	562	566	519	550
263:13:28: 3	411	915	838	931	925	958	562	566	520	550
263:13:29: 4	405	1029	840	931	924	958	563	566	520	551
263:13:30: 3	403	1017	841	933	925	958	563	566	519	551
263:13:31: 4	417	875	840	933	926	960	562	566	519	550
263:13:32: 3	391	859	836	933	926	959	562	566	519	548
263:13:33: 2	391	847	841	933	926	960	562	566	518	552
263:13:34: 2	403	894	843	934	927	960	563	566	519	550
263:13:35: 3	411	1007	840	933	928	961	562	566	519	550
263:13:36: 3	389	974	841	934	928	961	564	566	520	551
263:13:37: 2	391	972	838	934	928	961	562	566	519	550
263:13:38: 3	389	884	837	936	928	961	561	565	519	550
263:13:39: 3	415	697	837	937	926	961	561	563	518	550
263:13:40: 2	403	660	841	937	930	961	560	563	518	551
263:13:41: 3	401	978	842	935	930	962	561	565	519	550
263:13:42: 3	401	974	837	933	928	963	556	565	523	550
263:13:43: 3	409	908	843	935	930	963	558	563	526	550
263:13:44: 3	405	1027	843	936	930	964	561	564	525	548
263:13:45: 3	417	960	847	936	930	962	561	565	509	550
263:13:46: 3	407	888	845	937	931	964	561	563	500	549
263:13:47: 4	401	814	844	937	931	964	560	563	507	545
263:13:48: 3	387	1001	846	939	933	964	562	565	520	547
263:13:49: 2	415	962	848	939	933	965	564	566	527	547
263:13:50: 2	411	910	844	939	933	965	565	567	527	551
263:13:51: 2	401	986	846	939	933	965	565	567	524	550

C 88



## DAY 263 1984 DATA.7:00-17:00

TIME DAY:HR:MI:SE	FT382 10 LB/HR	FT411 10 LB/HR	TE301 DEC F	TE331 DEC F	TE332 DEC F	TE382 DEC F	TE383 DEC F	TE384 DEC F	TE386 DEC F	TE388 DEC F
263:13:52: 3	405	888	841	939	933	967	564	567	521	552
263:13:53: 3	387	974	844	939	933	967	563	566	519	553
263:13:54: 3	393	919	846	939	934	967	563	566	519	550
263:13:55: 2	413	970	844	940	934	969	563	566	520	551
263:13:56: 3	415	1058	844	939	934	969	562	566	520	550
263:13:57: 2	387	988	843	939	934	969	561	566	519	551
263:13:58: 3	387	943	844	940	934	969	560	566	518	550
263:13:59: 3	389	992	846	940	934	970	560	565	518	550
263:14: 0: 3	387	1059	844	942	936	970	560	565	517	550
263:14: 1: 3	413	862	846	942	935	970	560	565	517	548
263:14: 2: 2	399	1025	846	942	935	972	559	565	518	548
263:14: 3: 2	405	1026	846	942	937	972	558	565	519	548
263:14: 4: 2	405	962	848	944	937	972	558	563	520	547
263:14: 5: 3	391	957	848	943	937	972	558	563	520	547
263:14: 6: 3	411	824	846	944	937	973	558	563	519	547
263:14: 7: 3	397	927	848	944	939	973	557	563	518	547
263:14: 8: 3	399	1091	847	945	939	973	558	563	518	548
263:14: 9: 3	382	1121	848	945	939	973	558	563	519	547
263:14:10: 2	405	1058	847	945	939	973	558	563	520	547
263:14:11: 3	395	954	847	945	939	975	558	563	521	547
263:14:12: 3	411	1027	850	946	940	974	558	563	521	547
263:14:13: 3	401	958	850	946	940	975	558	563	520	547
263:14:14: 2	397	1019	847	946	940	976	558	563	520	548
263:14:15: 3	413	1032	850	946	940	976	558	563	520	547
263:14:16: 2	391	1050	847	946	940	976	559	565	520	548
263:14:17: 3	415	992	849	947	942	976	559	565	521	547
263:14:18: 3	411	946	849	947	942	976	559	565	521	540
263:14:19: 3	391	990	848	948	942	978	559	565	521	547
263:14:20: 4	389	1076	850	948	942	978	559	565	520	548
263:14:21: 3	368	1070	849	948	943	978	559	565	520	548
263:14:22: 2	389	1017	850	948	943	978	559	565	520	547
263:14:23: 3	382	962	852	948	943	978	559	565	521	548
263:14:24: 2	387	985	850	948	943	978	560	565	521	548
263:14:25: 2	389	1034	850	949	943	978	560	565	521	548
263:14:26: 2	389	1041	850	949	943	979	560	566	522	548
263:14:27: 3	393	1019	848	949	943	979	560	566	522	550
263:14:28: 3	399	1029	849	949	943	979	560	566	521	548
263:14:29: 3	424	1070	850	951	943	979	560	566	520	548
263:14:30: 3	384	1031	846	951	945	981	560	566	520	548
263:14:31: 2	387	964	846	951	945	981	560	566	520	550
263:14:32: 2	366	1035	846	951	945	981	560	566	520	548
263:14:33: 3	366	988	846	951	945	981	560	566	520	548
263:14:34: 3	378	1046	852	951	945	981	560	566	520	548
263:14:35: 2	395	1027	850	951	945	981	560	566	520	548
263:14:36: 3	405	1070	844	952	946	981	561	566	520	550
263:14:37: 2	397	1091	847	951	945	983	559	566	521	548
263:14:38: 2	364	1031	844	951	946	983	557	565	521	548
263:14:39: 3	387	974	849	951	946	983	557	563	521	547
263:14:40: 3	388	941	848	952	947	983	557	563	520	548
263:14:41: 2	360	1146	847	952	946	983	556	563	518	548
263:14:42: 2	376	1173	849	952	948	985	557	563	517	547
263:14:43: 3	362	1120	846	954	948	984	556	563	518	545
263:14:44: 3	380	1068	852	954	948	984	556	563	519	545
263:14:45: 4	385	1149	848	954	948	984	557	563	520	544
263:14:46: 3	382	939	848	954	948	984	557	563	521	545
263:14:47: 3	378	970	850	954	948	984	557	563	522	544

C-89

DAY 263 1984 DATA.7:00-17:00

TIME DAY:HR:MI:SE	FT382 10 LB/HR	FT411 10 LB/HR	TE301 DEC F	TE331 DEC F	TE332 DEC F	TE382 DEC F	TE383 DEC F	TE384 DEC F	TE386 DEC F	TE388 DEC F
263:14:48: 3	368	890	847	954	948	984	557	563	522	545
263:14:49: 2	366	978	849	954	948	986	557	563	521	545
263:14:50: 3	395	982	848	954	948	986	557	563	521	548
263:14:51: 3	399	1150	852	954	948	986	557	563	520	547
263:14:52: 2	384	933	846	954	947	986	557	563	520	545
263:14:53: 3	419	852	848	956	949	986	557	563	521	545
263:14:54: 2	399	958	844	956	949	986	557	563	521	545
263:14:55: 3	384	1013	850	956	949	986	557	563	521	545
263:14:56: 3	454	1145	852	956	949	987	558	563	520	545
263:14:57: 2	433	1097	844	956	949	987	558	565	520	545
263:14:58: 3	438	992	847	956	949	987	557	563	520	547
263:14:59: 3	469	900	849	956	949	987	556	563	521	545
263:15: 0: 3	436	1138	847	956	949	987	555	563	521	547
263:15: 1: 2	442	1050	847	956	951	987	554	563	521	545
263:15: 2: 2	448	946	849	956	949	986	554	561	520	545
263:15: 3: 2	411	1087	846	952	948	981	553	560	519	545
263:15: 4: 2	380	931	846	949	945	979	553	560	518	544
263:15: 5: 3	364	1212	844	948	943	976	552	560	518	544
263:15: 6: 3	378	988	846	946	941	975	552	558	518	542
263:15: 7: 3	362	948	846	945	940	973	552	558	518	542
263:15: 8: 3	366	1089	846	943	939	972	552	558	519	542
263:15: 9: 3	340	937	849	942	937	970	552	558	520	541
263:15:10: 2	358	1197	846	942	937	969	552	558	520	542
263:15:11: 3	340	859	844	940	935	969	552	558	520	541
263:15:12: 3	345	1166	848	940	934	967	552	558	521	539
263:15:13: 2	331	1005	845	939	934	967	552	558	521	541
263:15:14: 2	340	1019	840	939	933	965	552	560	521	542
263:15:15: 3	338	1091	841	937	933	965	552	558	522	541
263:15:16: 3	346	1116	847	937	931	964	552	558	522	542
263:15:17: 2	328	1066	846	937	931	964	553	558	521	542
263:15:18: 3	345	900	843	936	931	964	553	558	521	541
263:15:19: 2	345	1145	843	937	931	965	553	558	520	542
263:15:20: 2	360	834	843	937	931	964	553	558	520	542
263:15:21: 2	364	1208	844	937	931	964	553	558	520	541
263:15:22: 2	358	863	843	937	931	965	553	558	520	542
263:15:23: 3	347	837	844	937	931	965	553	560	520	541
263:15:24: 2	364	1212	843	939	933	967	553	560	520	541
263:15:25: 2	347	859	846	939	933	967	554	560	521	542
263:15:26: 3	333	1243	843	939	933	967	554	560	521	542
263:15:27: 2	366	1103	843	939	933	967	554	560	521	541
263:15:28: 2	347	970	843	939	933	967	553	560	521	541
263:15:29: 2	364	1292	846	939	934	969	553	560	521	542
263:15:30: 2	370	886	844	940	934	969	553	560	521	542
263:15:31: 2	364	1232	844	940	934	969	553	560	520	542
263:15:32: 2	347	933	846	940	934	969	553	560	520	542
263:15:33: 3	347	1197	847	940	934	969	554	560	520	542
263:15:34: 2	374	950	847	942	936	970	554	560	520	542
263:15:35: 3	360	1216	852	942	935	970	554	560	520	543
263:15:36: 2	360	1124	852	943	937	970	558	561	521	544
263:15:37: 3	364	933	850	943	937	970	563	565	522	543
263:15:38: 3	378	923	853	945	938	970	567	567	523	547
263:15:39: 2	358	908	843	942	937	970	563	569	524	548
263:15:40: 2	362	821	844	943	937	971	563	567	528	550
263:15:41: 2	350	873	846	945	937	972	563	567	532	550
263:15:42: 2	352	405	834	946	934	970	561	565	532	551
263:15:43: 2	366	593	838	948	936	970	559	563	530	552

C-90

TIME DAY:HR:MI:SE	FT382 10 LB/HR	FT411 10 LB/HR	TE301 DEC F	TE331 DEC F	TE332 DEC F	TE382 DEC F	TE383 DEC F	TE384 DEC F	TE386 DEC F	TE388 DEC F
263:15:44: 3	342	562	844	951	935	970	560	562	526	552
263:15:45: 3	358	616	837	951	924	970	559	560	521	551
263:15:46: 2	366	424	843	952	937	970	558	560	518	551
263:15:47: 3	362	391	846	952	937	970	558	558	515	548
263:15:48: 2	352	409	846	952	939	970	557	558	515	551
263:15:49: 3	344	474	846	952	940	970	558	558	520	548
263:15:50: 3	338	441	848	952	940	970	558	558	528	550
263:15:51: 2	368	329	832	948	939	969	555	560	532	551
263:15:52: 2	358	280	808	949	934	970	554	558	532	551
263:15:53: 3	372	87	829	954	933	969	556	555	529	550
263:15:54: 2	565	0	846	952	933	958	556	555	528	550
263:15:55: 2	880	104	852	908	924	841	558	555	525	552
263:15:56: 3	1600	471	812	831	892	765	557	557	522	550
263:15:57: 2	1600	393	757	788	852	747	556	555	517	548
263:15:58: 3	1600	243	740	768	823	732	556	555	510	548
263:15:59: 3	1600	269	725	754	800	730	555	555	506	550
263:16: 0: 4	1600	188	720	738	782	697	555	554	503	548
263:16: 1: 2	1600	120	710	690	757	638	553	554	500	548
263:16: 2: 3	1600	77	680	670	736	617	551	552	499	547
263:16: 3: 3	1600	18	663	644	716	585	548	551	500	545
263:16: 4: 3	1600	0	648	630	696	584	546	549	501	545
263:16: 5: 3	1600	0	631	621	682	584	545	548	508	544
263:16: 6: 3	1600	0	625	624	677	582	546	546	511	542
263:16: 7: 2	1600	0	623	630	684	581	553	546	504	545
263:16: 8: 2	1600	0	617	631	682	581	554	546	502	548
263:16: 9: 3	1600	0	612	630	677	582	556	549	501	552
263:16:10: 2	1600	0	608	630	673	581	557	551	500	553
263:16:11: 3	1600	0	603	621	662	581	555	552	499	554
263:16:12: 3	1600	0	600	618	654	579	555	552	503	553
263:16:13: 2	1600	28	599	613	650	581	555	552	510	554
263:16:14: 2	1600	421	596	610	644	581	555	554	518	555
263:16:15: 2	1600	0	596	605	638	579	555	554	500	553
263:16:16: 3	1600	0	595	604	635	580	555	552	498	555
263:16:17: 3	1600	0	593	598	627	576	554	554	496	553
263:16:18: 3	1600	0	587	586	613	578	547	552	495	548
263:16:19: 3	1600	0	585	587	605	579	544	549	498	544
263:16:20: 2	387	77	583	587	599	599	540	547	506	539
263:16:21: 3	311	185	566	587	596	604	537	549	509	534
263:16:22: 2	237	167	547	587	593	590	534	551	503	530
263:16:23: 2	311	456	543	587	590	589	532	551	494	524
263:16:24: 3	321	173	553	586	589	593	531	549	506	522
263:16:25: 2	385	372	556	584	589	595	533	549	512	525
263:16:26: 3	382	1600	554	581	585	596	530	547	518	525
263:16:27: 3	380	1600	550	579	582	598	531	547	521	525
263:16:28: 2	378	1600	544	578	578	596	530	546	463	513
263:16:29: 3	389	339	543	579	578	595	537	546	424	483
263:16:30: 3	376	262	536	579	576	596	543	546	418	499
263:16:31: 2	376	0	527	578	573	595	544	546	415	505
263:16:32: 3	377	0	522	576	570	596	542	546	415	521
263:16:33: 3	374	0	525	573	567	595	539	546	414	522
263:16:34: 4	366	0	527	572	566	596	537	546	413	524
263:16:35: 2	368	0	527	570	563	596	535	546	411	522
263:16:36: 2	360	0	528	569	561	596	533	546	410	522
263:16:37: 3	362	0	528	569	558	596	531	546	409	522
263:16:38: 2	362	0	528	567	556	596	529	547	408	520
263:16:39: 2	467	0	528	566	554	600	527	548	407	521

C91

ADDENDUM D  
TEST CONDUCTOR'S DAILY LOG

Daily Test Activity

Monday 4/9/84. No testing; equipment repair

- SGS; relief valve, insulation valve were repaired
- Static trouble shooting of the EPGs.

Tuesday, 4/10/84. No testing; equipment repair.

- SGS; reinstalled relief valve, replaced 2nd isolation valve.
- Static troubleshooting of the EPGs.

Wednesday, 4/11/84. No testing; (Lawrence Pump rep on site)

- Repaired CV-481 and reinstalled.
- Repaired FCV-471 with fast acting plug.
- Started reassembly of boost pump.
- Recalibrated LT-511 (hot well level)

Thursday, 4/12/84. EPGs testing.

- Reversed power wires to BWCP. Current dropped from 8.2 to 6.97 amps and circulation ratio increased from 4.7 to 8 plus at 10.3 k-lbs/hr steam. Pump was running backwards.
- Calibrated turbine RPM meter.
- Determined 1800 HZ from generator was a phantom induced by measuring technique.  
Determined that temperature of the steam line to the feedwater heater is low.
- Analyzed turbine vibration G meter O.K., vib level 2.5 G's (O.K.), 250 HZ <.001" displacement.

Friday, 4/13/84. EPGs testing.

- Sync'd to grid for 38 minutes 3 sec. with the reverse power trip disabled; manually tripped turbine.  
Output was 800 amps.  
Steam flow 11.1 k-lbs/hr. FCV-431 closed.  
BWCP 7.1 amps; CR 8.0. DA press decreasing.

Monday, 4/16/84. EPGs testing (GE representative on site).

- Synchronized to grid for 21 minutes. GE agreed with PNM previous generator findings. GE recommends to disconnect generator and backfeed, check relays and all meter wiring.
- Boost pump ready for installation.
- Difficult to control propane heater temperature without salt flow.

Tuesday, 4/17/84. No testing; equipment maintenance.

- Removed BCS target off tower.
- Continued valve/line insulation on top of hot salt tank.
- Cooling tower fans trip out during operation; electrical contractor to repair.

Wednesday, 4/18/84. No testing; equipment maintenance.

- Installed boost pump inside pump house.
- Replenished half of the available salt inventory.
- Repaired the extra heat trace connections for cold salt tank.
- EMCON-scheduled maintenance all day.
- Static tests of generator system with PNM (resolved generator anomalies, phasing reversed from grid transformer to facility circuit breaker).
- Installed shallow well cycle fill pump.

Thursday, 4/19/84. No testing; equipment maintenance.

- Started boost pump hook-up.
- Continued valve/line insulation.
- Reinsulated inlet valve/line to feedwater heater.
- Completed replenishment of salt inventory.
- Readjusted and tested propane heater motor control linkage.
- Completed EMCON-scheduled maintenance.

Friday, 4/20/84. No testing, equipment maintenance (snow & wind).

- Could not charge hot tank; PCM 3 down until 0930; then FCV-242 too cold.
- Boost pump hookup continues; cannot complete hook-up to cold sump.
- Reconnected PT-180 from PT-281 in preparation for boost pump operation.
- Resealed SGS leaking temperature transmitter; however, requires replacement due to poor threads.
- Temporarily covered valves on top of hot tank for weather protection.
- Troubleshooting cycle fill pump suction line.

Monday, 4/23/84. No testing; equipment maintenance and repair.

- Completed insulation of valves/lines on top of hot salt tank except FCV-242 (propane heater outlet).
- Started EPS mods for EPGs
- Started troubleshooting leak in HRFS cycle fill pump suction line.
- Completed pipe connections of boost sump.

Tuesday, 4/24/84. No testing; equipment maintenance and repair.

- Completed electrical hookup of boost pump and trace heaters to boost sump.
- Started insulation of boost sump/pipes.
- Installed pneumatic lines to LT-161/161A.

Wednesday, 4/25/84. No testing; equipment maintenance and repair.

- Completed boost sump/piping insulation.
- Recalibrated FCV-241, 221, 201, and LT-161 positioners.
- Walk thru training of technicians for PCM #1 (receiver) failure.
- Power failure at 1614; high winds up to 70 mph at top of tower.
- Repaired cycle fill pump suction line.

Thursday, 4/26/84. Snow and cold. Checkout of boost pump/sump.

- Checked out boost pump/sump; no anomalies.
- FCV-151 from boost sump out of calibration.

Friday, 4/27/84. Pool solar; EPGs and SGS testing.

- Synchronized to grid, 48 minutes, intentional manual trip.
- Attempted SGS SGITP #6 feedwater loss shutdown; aborted due to high evaporator temp during steam drum level reduction.

Monday, 4/30/84. No testing; equipment repair

- Installed new plug in FCV-471.
- Calibrated FCV-101, 102, 161 and 162 signals.

Tuesday, 5/1/84. Receiver start-up; no anomalies.

- Started receiver with automatic fill sequence. Shut down manually due to FT-101 calibration.
- Verified calibration of LT-151 cold surge tank.
- Calibrated FT-101 at 54 k#/hr; at 30 k#/hr, FT-101 reads 37; therefore, could not use auto drain sequence. Will recalibrate on 5/4.
- Repaired damaged receiver wind shields.
- Completed salt valve signal calibrations.
- Repaired spray water pump.

Wednesday, 5/2/84. No testing; poor solar, and windy; cold valves (FCV-101/102) and lower header.

- Equipment repair and maintenance.
- Continued insulation effort.
- Discovered leak in HV-487; SGS will not sustain diurnal shutdown.

Thursday, 5/3/84. No testing; EMCON (DEC) down until 14?? (repro copy bad)

- EMCON repaired at 1415.
- Attempted receiver tests; aborted due to clouds and winds.

Friday, 5/4/84. No testing; windy, cold valves and header.

- Started SGS at 0500.
- Developed new warm-up heliostat pat???? (bad repro)
- Charged hot tank using propane heater.

Monday, 5/7/84. No testing; equipment maintenance (windy).

- Added new shutoff valve between HV-487 and Trap 482. SGS now sustains diurnal shutdowns.
- Attempted receiver testing; aborted due to high winds gusting to 50 mph.
- New warm-up heliostat pattern works very well (800°F-450°F).

Tuesday, 5/8/84. Receiver testing.

- Recalibrated FT-101.
- Receiver temp algorithm tests; FD-101 tuned; need another day to complete algorithm.

Wednesday, 5/9/84. Complete system test synchronized to grid.

- All subsystems up, synchronized to grid (640 kW), 39 minutes.
- Produced electricity from storage without receiver; 2-hr. capacity available.
- Leak in Olin salt loop.
- FCV-471 very noisy (will reinstall fast plug).
- GCV-211 air bellows ruptured; parts ordered.
- Quarterly Review Meeting.

Thursday, 5/10/84. SGS subsystem tests.

- Performed SGITP #6 loss of water flow.
- Performed SGITP #7 loss of salt flow.
- Replaced positioner on FCV-401.

Friday,, 5/11/84. EPGS testing from control room.

- Replaced FCV-471 plug back to a fast acting plug; other one very noisy.
- Synchronized to grid from control room; 10 minutes.
- Operated Olin salt loop.

Monday, 5/14/84. No testing (windy); equipment maintenance.

- Retuned FCV-201.
- Repaired receiver door thermocouples.
- Removed spray water pump seal for replacement.

Tuesday, 5/15/84. No testing (windy, partial solar).

- Installed new seal in SWP.
- Installed base communication station in EPGS.
- Reliability and spare parts meeting.

Wednesday, 5/16/84. EPGS testing; sync'd to grid for 35 minutes.

- Performed EPITP #1 control loop tuning.
- Performed EPITP #2 no load sync to grid.
- Retuned FCV-491 slightly slower at higher press (1050 psi).
- FT-311 and PT-321 in SGS leak.

Thursday, 5/17/84. EPGS testing; total system on grid for 2 hours.

- Total system up with 100% heliostats (194) for 2 hours.
- Performed EPITP #4 generator load ramping.

Friday, 5/18/84. EPGS and system testing.

- Performed SITP #1 manual sequence demonstration, sync'd to grid for approximately 2 hours.
- Performed EPITP #7 margin test.
- Performed EPITP #6 emergency power failure (without receiver).

Monday, 5/21/84. EPGS testing with system sync'd to grid.

- Partially performed EPITP #3 steady state load with transients.
- Discussed last week's emergency shutdown; additional procedure and possible equipment update required prior to system emergency test.

Tuesday, 5/22/84. Receiver temperature algorithm test.

- Analyzed receiver temperature algorithm.
- Performed flow response test.

Wednesday, 5/23/84. Receiver temperature algorithm test.

- Checked calibration of FT-101 using cold sump depletion method.
- Stagnated salt in receiver to check FT-101 zero.
- Lost signal from LT-151 during fill process.
- Boost pump stopped during testing.

Thursday, 5/24/84. Receiver temperature algorithm test.

- Recalibrated FT-101 zero and span.
- Checked algorithm with temperature step changes.
- Determined maximum flow thru receiver is 91 k-lbs/hr with FCV-101/102, 100% open.

Friday, 5/25/84. No testing; equipment maintenance and repair.

Monday, 5/28/84. Holiday.



Tuesday, 5/29/84. Equipment repair.

- Completed tie-in from wet cooling tower.
- Started SGS leak repair.

Wednesday, 5/30/84. Equipment repair.

- Welded new FCV-411 in place on SGS skid.
- Determined leaks around FT-311 and PT-321 are in threaded connections.
- Started reinsulating FCV-101/102 on receiver.

Thursday, 5/31/84. Equipment repair.

- Replaced packing on FCV-501 (EPGS main steam valve).
- FCV-101/102 insulation completed; require mudding and weather proofing.

Friday, 6/1/84. Equipment repair.

- Welded SGS FT-311 and PT-321 connections.
- Did not mud FCV-101/102 due to inclement weather.

Monday, 6/4/84. No testing; equipment repair.

- Completed reinsulation of FCV-101/102.
- Completed repair of SGS leaks.
- Completed HRFS pumps feedback to EMCON.

Tuesday, 6/5/84. No testing; pool solar; equipment repair.

- Corrected loose wire on TT-484.
- Installed new gasket on FCV-491.
- Pre-conditioned hot tank to 700°F using propane heater.
- Prepared HRFS & SGS for start-up.

Wednesday, 6/6/84. No testing; system start-up.

- Started HRFS & SGS.
- Charged hot tank using propane heater.
- Trace heater on FCV-193, 194, 195 purge valves inoperable, redundant electrical circuit activated.

Thursday, 6/7/84. No testing; equipment failure.

- Water in lube oil system in FWP.
- Disassembled FWP and ordered seals; due in Monday 6/11/84.
- Need to install NPSH gage on suction side of FWP.
- Discussed receiver windshield installation with outside contractor.

Friday, 6/8/84. Receiver cloud test.

- Performed RITP #6 cloud test.
- Monitored receiver temperature algorithm response to heliostat variations and temp set point variations. (Requires additional testing.)
- Both riser and downcomer did not allow receiver to fill for approximately 30 minutes. Frozen salt suspected in lines above hot tank prior to crossing bridge.

Monday, 6/11/84. No testing; equipment repair.

- Reassembled FWP.
- Reworked TE 101/102 for differential reading for Phase II tests.
- Trace heater failed on FCV-180/181, redundant activated.
- Completed receiver FCV-190/191 windshield; started on drain valves.

Tuesday, 6/12/84. No testing; equipment repair.

- Reinstalled FWP; cold alignment completed.
- Completed drain valve and lower header windshields.
- Reinsulated elbow near TE-161 on top of hot tank.
- Prepared HRFS & SGS for start-up.

Wednesday, 6/13/84. Attempted Phase II receiver testing, aborted due to cold riser.

- Riser trace heater turned off due to loose wire back of Acurex scanner; anomaly corrected. Temperatures increase approximately 1°F/min.
- Started HRFS & SGS.
- Boost pump started without command; troubleshooting revealed incorrect wiring.
- FWP hot alignment checked within spec; no adjustment required.

Thursday, 6/14/84. Phase II testing; Receiver Test II-3.

- Performed first six cases of Test II-3; receiver algorithm performed satisfactorily with simulated slow clouds.
- Temporary salt blockage during start-up. Line from FCV-151 above hot tank requires reinsulation.
- Will let FCV-161, 162, 151, and 199 drain for three days to determine if drain back was part of salt blockage problem.
- 0 LT-151 cold surge tank level transmitter still erratic.

Friday, 6/15/84. No scheduled testing; windshield installation.

- Completed FCV-198 east purge valve windshield.
- Two hours remain to complete FCV-101/102 windshield installation; this will complete the receiver windshields.

Monday, 6/18/84. Attempted system test.

- Completed receiver windshield installation.
- Attempted system test; salt blockage in receiver due to cold header and weather.

Tuesday, 6/19/84. No testing.

- Determined location of salt blockage in receiver—Passes 4, 5, 8, 9, 10 and 11.
- Analyzed alternatives to free salt blockage.
- Developed procedure to free blockage; start at top of receiver.
- Installed new plate in FCV-211.

Wednesday, 6/20/84. Attempted to free blockage.

- Aborted test to free blockage due to losing PCM #1 twice; false signal scrambled heliostats and clouds.
- Successfully checked operation of FCV-211.
- Filled SGS with water.

Thursday, 6/21/84. Receiver checkout.

- Successfully freed receiver salt blockage; no visual damage.
- Established serpentine flow thru receiver, tested with 25% field for 40 minutes.
- Trace heater to drain valves FCV-184/185 failed; redundant activated.

Friday, 6/22/84. Equipment repair.

- Determined location of feedwater leak in weld between FWP and FCV-401; contractor to repair Monday, 6/25/84.

Monday, 6/25/84. No solar; equipment repair.

- Added insulation to lower header inside receiver cavity.
- Welded leak in recirc line of FW system.
- Started HRFS and SGS to warm standby.
- Repacked HVO465; FWP suction side.

Tuesday, 6/26/84. No solar; EPGS testing.

- Performed EPITP #3, sync'd to grid two hours.
- Closed HV-586 (seal steam); reduced back press to 9 inches Hg; obtained 762 kW.
- Turbine tripped at 688 kW due to high exit temperature of generator cooling air; DA handled steam dump.

Wednesday, 6/27/84. Phase II receiver testing.

- Trace heater on outlet line of propane heater failed; repaired junction, heater on.
- Continued with Test II-3 receiver testing.
- Temporary anomaly with micros on receiver door.
- Lower east header outlet requires reinsulation and possible wind shielding.

Thursday, 6/28/84. Phase II receiver testing.

- Receiver temp algorithm testing continued.
- Olin in to start Olin salt loop.
- Discussed power loss emergency procedure.

Friday, 6/29/84. Equipment maintenance.

- Repaired leak in FCV-501 steam to turbine.
- Mudded reinsulation line from cold surge tank to FCV-101/102.

Monday 7/2/84. Aborted system testing.

- Attempted Phase I system testing, aborted due to excessive steam leakage thru FCV-501.
- Attempted Phase II, Test II-3 receiver testing, aborted due to erratic FT-101, ordered new gaskets for FT-101 prior to troubleshooting.

Tuesday, 7/3/84. No testing; equipment repair.

- Prepared FCV-421, steam inlet to FW heater, for removal/replacement.
- Drained hot tank completely.

Wednesday, 7/4/84. Holiday.

Thursday, 7/5/84. Equipment repair.

- Routed electrical wiring to new FCV-411.
- Started removal/replacement of FCV-421.

Friday, 7/6/84. Equipment repair.

- Completed removal/replacement of FCV-421 valve body only. Will install controller and hookup on Monday, 7/9/84.

Monday, 7/9/84. No testing; equipment repair.

- Installed trim and plug on new FCV-421.
- Removed FT-101; frozen salt on damaged diaphragm. New transmitter to be ordered.
- EMCON reprogrammed to use PT-181 for temp algorithm control.

Tuesday, 7/10/84. No testing; equipment repair.

- Hooked up FCV-421 electrically and pneumatically.
- Reinsulated outlet of lower east receiver header.
- Reinsulated Olin loop.
- Requested heliostat files at staggered standby points to increase ramp rate for transient tests.
- Reviewed transient test results with MMC (also Wednesday).

Wednesday, 7/11/84. No testing; equipment repair.

- Insulated new FCV-421.
- Filled HRFS and SGS; started to diurnal condition.
- Tour for four PNM personnel; two due in 7/16 to assist CRTF as field techs.
- Technical Committee Meeting.

Thursday, 7/12/84. Solar tests to C/O new hardware.

- Receiver test with PT-181 in place of FT-101.
- FW temp still low with new FCV-421.
- Charged hot tank.
- Three trace heaters in Olin loop failed.
- MSEE Quarterly Review.

Friday, 7/13/84. The page this was on is missing.

Monday, 7/16/84. System tests.

- Sync'd to grid for 37 minutes; started SITP #4 & 5.
- Started training two PNM field technicians. They will rotate every six weeks.
- Obtained 550°F feed water without impulse device in T-484.
- Partially tuned FCV-421.

Tuesday, 7/17/84. EPGS tests; propane heater.

- Sync'd to grid for one hour.
- PNM recommendations on EPGS.
  - o Provide air bleed capability on generator heat exchanger and oil cooler.
  - o Start turbine locally and slowly.
  - o Sync to grid, then soak turbine.
  - o Watch power factor more closely.
- FWP cooling loop sight glass cracked open; temporarily bypassed.
- Reset turbine pressure trip to 750 psi.
- Reset generator air temp trip to 120°F; was miscalibrated to 95°F.

Wednesday, 7/18/84. System tests; completed Phase I.

- Completed SITP #4, 5, 6, & 7.
- Sync'd to grid for approximately 1-1/2 hours.
- PNM comments
  - o MSEE is understaffed. Could result in equipment damage and expose personnel to extra hazards.
  - o FCV-501 should be interlocked to throttle valve. (Critical; could destroy turbine.)
  - o Need auto restart on electric oil pump following turbine trip.
- TE-188 receiver pass outlet #5 reads 176°F; probing revealed temperature was 550°F. Will troubleshoot instrumentation.
- Downcomer was cold (375°F). Preliminary troubleshooting indicated a faulty relay contact on the Acurex relay card.

Thursday, 7/19/84. System transient tests.

- Sync'd to grid for 3 hours.
- Retuned FCV-421 and changed set point to 520°F for feed water.
- Turbine ramp is critical; 10% per minute max.
- Performed receiver transient test at 900° and 950°F with simulated 25 sec cloud.
- The HRFS cycle fill pump can only be started remotely and stopped locally; will troubleshoot.

Friday, 7/20/84. Equipment maintenance.

- Started windshields on receiver east end.
- Replumb feed water pump cooling loop.
- Partial order for spare trace heaters.

Monday, 7/23/84. Receiver testing attempted.

- During receiver fill downcomer was blocked; all temperatures were acceptable. Receiver door micro malfunctioned, not allowing door to open. Receiver was drained through the riser and, subsequently the downcomer was freed up, filling the downcomer only.
- PNM recommended CRTF bring in a Bailey Controls rep to review our overall controls strategy.
- Receiver door micro readjusted.

Tuesday, 7/24/84. Poor solar; no testing.

- Checked information TCs on bridge, 193°F, 376°F, 493°F, and 556°F.
- Probed two elbows, midway on bridge downcomer, 305°F and 450°F.
- New FT-101 in house and calibrated.
- Walked the entire bridge feeling for hot spots and checking pipe slopes. Four places on the downcomer and riser were sloped the wrong way.. Many hot spots on riser and downcomer.

Wednesday, 7/25/84. No solar and high winds; no testing.

- PNM chemist in to recommend HRFS water chemistry required.
- PNM recommends DA sight glass and other level sight glasses be revalved to allow steam cleaning in place.
- SWP seal surface warped causing SWP to leak severely. New kit due in next week.
- Charged hot tank using propane heater.

Thursday, 7/26/84. Receiver testing.

- Finalized receiver auto fill and drain sequences.
- Only one TC on riser and downcomer on bridge near the hot tank. Approximately 75 feet of bridge without temp instrumentation.

Friday, 7/27/84. Maintenance.

- Replaced SGS chemical feed pump.
- Continued receiver east end wind shielding.
- Cleaned pump house.

Monday, 7/30/84. Receiver testing.

- Verified new heliostat warm-up pattern that heats up lower east-west corners more rapidly and uniformly.
- Performed three consecutive receiver auto fill and drain sequences.
- FCV-211 salt valve to cold sump diaphragm ruptured. This is temporarily a manual operated valve.
- Terminated testing due to FWP cooling water seal failure, passing steam to drain.

Tuesday, 7/31/84. No testing; equipment repair.

- Discussed FWP cooling with Ingersol Rand design engineer. He will send us a cyclone separator to prevent contaminants entering the seal area.
- FCV-186/187 drain valve trace heater failed; activated redundant circuit.
- Checked out new SGS chemical feed pump. Capable of filling SGS drum level using this pump, thus eliminating start-up of HRFS and FWP.

Wednesday, 8/1/84. Receiver testing and equipment repair.

- Reassembled FWP with new seal and cold aligned FWP.
- PCM #3 power supply failed; replacement due in 8/2/84.
- Receiver outlet temperature drifts from 1034 to 1044°F with clear sky and set point at 1040°F.
- Charged hot tank using receiver.

Thursday, 8/2/84. SGS testing.

- Checked out revised SGS start-up sequence to be used in auto start-up; areas to be resolved:
  1. FCV-411 leak by, need to keep HV-488 closed until start-up.
  2. FCV-221 leak by, need to control hot sump level with FCV-231.
  3. Drum swelling above 7 inches during fill will shut off salt valves.
- DA sight glass mica was ordered, sight glass temporarily valved out.
- FWP cooling water heat exchangers are not passing adequate water through for cooling; system shut down to troubleshoot.

Friday, 8/3/84. Equipment repair.

- Installed two steam traps in SGS and two steam traps in EPGS.
- Disassembled and cleaned FWP cooling water heat exchangers (3); exchangers completely clogged up with scale, etc., on outside of coils.

Monday, 8/6/84. Trial team training—overview.

- Start trial team training, system overview and classroom.
- Completed FWP cooling loop repair.
- Installed new drum level sight glass in SGS.
- Completed receiver east end wind shielding.

Tuesday, 8/7/84. Trial team training—receiver cold flow.

- Trial team performed receiver start-up to cold flow.
- Repaired receiver door micro switch.

Wednesday, 8/8/84. Trial team training—propane heater.

- Trial team performed receiver cold flow in the morning.
- Trial team charged hot tank using propane heater in the afternoon.
- During propane heater operation, the boost pump started, ran approximately one minute, and stopped without any commands; this is still unsolved.

Thursday, 8/9/84. Trial team training—SGS

- The heliostat power transfer switch from commercial to diesel generator burned up on switchover; requires major rewiring.
- Trial team attempted to start SGS; salt burst disc from the evaporator ruptured requiring test to be aborted; salt outlet valve (FCV-321) was not open, causing discs to experience cold pump discharge pressure.

Friday, 8/10/84. Trial team training—control room exercises.

- Conducted a detailed post-test analysis discussion. The burst discs are designed nominally for 167 psi at 530°F. The cold pump discharge deadheaded is approximately 180 psi.
- Trial team performed EMCON exercises in control room.
- Evaporator burst disc replaced with spare. Four new higher pressure burst discs ordered; due in 8/16/84.

Monday, 8/13/84. Trial team training - SGS.

- Trial team performed SGS start-up and shutdown.
- Completed repair of heliostat power transfer switch Row 12 east-west and Row 13 west are inoperative pending final troubleshooting and repair.

Tuesday, 8/14/84. Trial team training - receiver hot flow.

- Trial team performed receiver start-up to hot flow and slow cloud transients.
- Conducted detailed tour of EPGS for trial team.
- Boost pump intermittently noisy; will replace the three matched "V" belts.

Wednesday, 8/15/84. Trial team training - EPGS.

- Charged hot tank using propane heater in preparation for trial team.
- Trial team performed SGS start-up thru EPGS on line and sync'd to grid for 20 minutes.

Thursday, 8/16/84. Trial team training - system.

- Trial team performed system start-up with receiver, then sync to grid.
- Due to clouds, receiver was shut down and propane heater started while sync'd to grid. Remained sync'd to the grid for 2 hours and 3 minutes total; 600 kW max.
- Replaced power relay in downcomer trace heater circuit; delayed testing one hour due to cold downcomer.
- Boost pump started without being commanded. Preliminary troubleshooting isolated anomaly in 24V wiring; repair scheduled for next week.

Friday, 8/17/84. Trial team training - SGS.

- Trial team performed SGS start-up and shutdown.
- Performed debriefing of trial team with CRTF personnel participating.

Daily Activity - 8/20/84 - 8/24/84

- Receiver Subsystem

1. Repaired ZSH-189 micro on drain valve.
2. Attempted repair on several trace heaters; junction repair difficult to impossible due to access.

- Thermal Storage Subsystem

1. Reinsulated FCV-241 inlet to propane heater.
2. Reinsulated salt line outlet of propane heater.
3. Continued troubleshooting boost pump circuit to determine pump start-up without command; cause is still undetermined.

- Steam Generator Subsystem

1. Repaired leak in FCV-491 main steam outlet from SGS.
2. Coded auto shutdown sequence.

- Heat Rejection Feedwater Subsystem

1. Installed larger cooling water surge tank on east donut.
2. Repaired DA level sight glass and replumbed for wash capability.
3. Changed FWP oil and filter.
4. Repacked HV-455 and HV-456.
5. Valved out CMUP air accumulator.

- Electric Power Generation Subsystem

1. Recalibrated and reconnected TS-502.
2. Provided turbine exhaust temperature readout to EMCON.

- Thermocouples

1. Repaired Channel 309.
2. Determined TC channels 106, 107, 115, and 118 are not connected to the process piping and read in the range of 380-430°F.

- Heliostats

1. Repaired rows 12 and 13 west; row 12 east repair due for completion on 8/28/84.

Daily Activity - 8/27/84 - 8/31/84

- Receiver Subsystem

1. Completed troubleshooting trace heater repair.
2. Repaired flux gage cooling line flow indicator.
3. Turned on trace heaters for next week's operations.

- Thermal Storage Subsystem

1. Repaired wiring on large air compressor.

- Steam Generator Subsystem

1. Replaced burst disc on evaporator side with new 177 psi disc and reinsulated line.
2. Fabricated and hinged new cover plate on flow down tank to divert salt/steam away from SGS.
3. Installed new plug, stem,, and control components in new FCV-411.
4. Partially hooked up electrical/pneumatic lines to new FCV-411.

- Heat Rejection Feedwater Subsystem

1. Installed timer on FWP cooling line to allow cooling to continue subsequent to pump shutoff.



- Electric Power Generation Subsystem

1. Replumbed turbine condensate recirculation line.
2. Added local pressure gage at PT-583.

- Heliostats

1. Completed repair of row 12 east.

Monday, 9/3/84. Holiday.

Tuesday, 9/4/84. Utility team training—overview.

- System overview and classroom training.
- Replaced a card in Acurex; temp readings restored.

Wednesday, 9/5/84. Utility team training—control room exercises.

- Team performed EMCON exercises in control room.
- Running cycle fill pump continuously to clean up feedwater.

Thursday, 9/6/84. Utility team training—receiver.

- Team warmed up receiver panel and talked thru receiver fill and drain sequence in control room.
- Lower receiver header cold (200°F - 300°F); south winds 15-20 mph.

Friday, 9/7/84. Utility team training—propane heater.

- Team charged hot tank using propane heater.
- Shielded south end of receiver with tarpaulin; lower header temps increased from 200 to 450°F. Wind shielding required.
- Installed cyclone separator in FWP.

Monday, 9/10/84. Utility team training—receiver

- Team started receiver subsystem and performed hot flow through shutdown.
- Boost pump started without being commanded.

Tuesday, 9/11/84. Utility team training—SGS.

- Team training on SGS subsystem.
- Receiver drain valve, FCV-183, redundant trace heater failed; successfully repaired in four hours.
- Olin Chemical started replacement of Olin loop trace heaters.
- Checked out SGS auto shutdown sequence.

Wednesday, 9/12/84. Utility team training—MSEE Progress Review

- Team training on SGS with control room console exercises.
- MSEE progress review meeting.
- MSEE technical committee meeting; preliminary Phase III plan presented.
- Receiver south end wind shielding effort started.

Thursday, 9/13/84. Utility team training—MSEE dedication.

- Team operated receiver subsystem in the morning.
- Team started SGS subsystem in the afternoon, generated steam and shutdown subsystem using auto sequences successfully.
- MSEE dedication at Central Receiver Test Facility.
- MSEE sponsors committee meeting; preliminary Phase III plan discussed.

Friday, 9/14/84. Utility team training—EPGS.

- Team training on EPGs subsystem.
- Receiver lower deck wind shielding completed.
- Boost pump V-belts replaced by matched set.
- Olin loop traced heater installation and reinsulation completed.

Monday, 9/17/84. Utility team training; receiver hot flow

- Team operated receiver and charged hot tank.
- SGS trace heater (Mark #3507) failed; redundant activated; SGS and EPGs testing aborted due to cold salt line.

Tuesday, 9/18/84. Utility team training; system test.

- Team operated complete system; synchronized to grid for 47 minutes.
- Steam outlet valve FCV-491 leaks at bonnet.
- Olin loop operational; 7 GPM.
- While receiver door was opening, the door close signal came on without command and started closing the receiver door.
- SGS level sight glass leaks.

Wednesday, 9/19/84. Utility team training; system test.

- Team operated complete system; synchronized to grid for 3 hours 28 minutes.
- Most of Olin loop trace heaters failed; Olin loop not operational; Olin was notified.
- Spray water heat exchanger leaks.

Thursday, 9/20/84. Utility team training; SGS operation and system debriefing.

- Team attempted starting SGS; aborted during hot salt ramp up due to PCM #2 failure.
- Team provided evaluation of training class and MSEE.
- Performed debriefing of utility team with CRTF personnel participating.

Friday, 9/21/84. Utility team training; Solar One

- Team participated in tour of Solar One.
- Receiver south end wind shielding continued.

Monday, 9/24/84. Utility team training—overview and MCS.

- System overview and classroom training.
- Replaced SGS sight gage.
- Cleaned FWP cooling water heat exchangers.
- Installed HV-570 in condenser recirculation line.
- Completed receiver wind shielding.

Tuesday, 9/25/84. Utility team training—receiver and thermal storage.

- Team received receiver and TSS training and performed control room exercises.
- Started equipment freeze protection effort.

Wednesday, 9/26/84. Utility team training—receiver.

- Team talked through receiver fill and drain sequence in control room.
- TSS trace heater E, boost pump outlet, failed; redundant activated; heater destroyed by salt corrosion.
- Installed lock washers on spray water heat exchanger and retorqued studs to 200 ft. lbs.
- Installed air bleed valve on turbine/gen air heat exchanger.
- Repaired leaking steam drum valve.
- Eliminated SGS Net 90 graphics BWCP anomaly.

Thursday, 9/27/84. Utility team training—receiver cold flow.

- Team attempted receiver start-up; aborted due to salt plug in downcomer.
- Momentary power failure forced an emergency shutdown of receiver fill sequence using local control at PCMs.
- CRTF personnel freed up salt plug by filling up downcomer only (team observed operation).
- Solenoids on receiver purge valves FCV-191/194 are noisy.

Friday, 9/28/84. Utility team training—propane heater.

- Team attempted receiver start-up; aborted due to winds gusting to 50 mph.
- Team training on propane heater operation.
- Team charged hot tank using propane heater.
- Boost pump started without being commanded from EMCON.

Monday, 10/1/84. Utility team training—receiver hot flow.

- Team operated receiver in hot flow, simulated clouds,, and actual clouds.
- Cold sump was 458°F; only one of three trace heaters was on.

Tuesday, 10/2/84. Utility team training—receiver cold/hot flow.

- Team filled and drained receiver three times and operated in cold flow.
- Team operated receiver in hot flow with actual clouds.

Wednesday, 10/3/84. No solar—rain; utility team training—SGS.

- Team training on SGS subsystem.
- DA manhole leaked; installed new gasket.

Thursday, 10/4/84. No solar—rain; utility team training—SGS.

- Team tour of SGS.
- Completed team training of SGS with control room exercises.
- Redundant trace heater C (outlet from cold sump) failed.
- Two replacement trace heaters installed.

Friday, 10/5/84. Utility team training—EPGS.

- Team training on EPGS subsystem.
- Insulated TSS cold sump outlet line and activated new trace heater.
- Cleaned top of tower.
- SGS drum level sight glass cracked.

Monday, 10/8/84. Utility team training—receiver hot flow.

- Team operated receiver in hot flow and charged hot tank.
- Temporarily valved out SGS drum level sight glass due to leak.

Tuesday, 10/9/84. Utility team training—SGS/EPGS.

- Team started SGS and ramped to hot flow.
- Team participated in local start-up of EPGS and sync'd to grid for 35 minutes.
- Hot salt inlet to SGS (FCV-351) does not respond to command from EMCON or Net 90. Corroded wire at valve junction box was repaired. FCV-351 receiving spurious signal that opens valve 2-3%.

Wednesday, 10/10/84. Utility team training—propane heater.

- Team attempted receiver start-up; aborted due to boost pump failure (damaged upper bearings). CRTF performed emergency shutdown.
- Team charged hot tank using propane heater.
- Fabricated and replaced DA manhole cover bracket.
- Team debriefing of MSEE.

Thursday, 10/11/84. No solar; utility team training—system operation.

- Boost pump repair completed.
- CRTF started system and sync'd to grid for 32 minutes using propane heater; APS team observed.
- Cycle fill pump leaks.
- Early shutdown due to spray water pump leak.
- Team provided evaluation of training class and MSEE.

Friday, 10/12/84. Utility team training—Solar One.

- Team participated in tour of Solar One.
- Modified FCV-211/231 as single control open/close valves.
- Changed turbine oil. Monday, 10/15/84. Utility team training—overview.
- System overview, Master Control System and classroom training.
- Changed FWP oil and filter.
- Attached thermocouples to trace heater sheath (line between cold sump and boost sump) 100-200°F higher than process.
- Spray water pump to machine shop for repair.

Tuesday, 10/16/84. Utility team training—receiver and thermal storage.

- Team received receiver and TSS training and performed control room exercises.
- Replaced two wind removed sections of purge valve wind shielding panels.
- Trace heater failed on drain line from boost sump to cold sump. Insulation was salt soaked; reinsulated and redundant heater activated.

Wednesday, 10/17/84. Utility team training—receiver.

- Boost pump was readjusted due to noise; all normal.
- CRTF started receiver to hot flow to verify system integrity.
- Team performed cold flow from cold sump to cold tank only.

Thursday, 10/18/84. Utility team training—receiver cold/hot flow.

- Team started receiver; performed cold and hot flow (1042 w/m<sup>2</sup>).
- Diesel generator #1 leaks oil; generator #2 leaks diesel fuel.
- Spray water pump installation completed; slight leak due to used seal.
- Receiver flow transmitter FT-101 band heaters are in house.

Friday, 10/19/84. Utility team training—receiver hot flow/clouds.

- Team operated receiver in hot flow with real clouds and charged the hot tank.
- Heliostat power transfer switch is again anomalous (draws current with no load); Sandia is troubleshooting.
- Spray water pump requires additional repair.

Monday, 10/22/84. Utility team training—SGS training.

- Team tour of SGS.
- Completed team training of SGS with control room exercises.
- Replaced spray water pump seal; no leaks.
- Replaced micro switch on receiver door.

Tuesday, 10/23/84. Utility team training—propane heater.

- Team operated propane heater and charged hot tank.
- Damaged insulation on outlet of propane heater due to hot start-up.
- Two SGS water valves leak (chemical feed pump supply, and steam drum sight glass isolation valve).
- Olin started replacement of trace heaters in Olin loop.
- CRTF reviewed emergency shutdown procedures.

Wednesday, 10/24/84. Utility team training—SGS cold flow.

- Team operated SGS in cold flow; two start-ups and shutdown.
- Reinsulated propane heater outlet line.
- Control wire on hot salt control valve to SGS corroded off; position indicator loose and out of adjustment.
- Two Olin loop boxes trace heaters replaced.

Thursday, 10/25/84. Utility team training—SGS hot flow operation.

- Team operated SGS in hot flow; auto and manual rampup.
- Team charged hot tank using propane heater.
- Slight leak in SGS thermocouple connection at TE-332.

Friday, 10/26/84. Utility team training—EPGS training and operation.

- Team training on EPGS subsystem.
- Team operation of EPGS.
- Team shutdown SGS.
- Olin loop operational.

Monday, 10/29/84. Utility team training—system operation.

- Team operated system and synchronized to grid 3 hr. 39 min. (a new one-day record).
- Heliostat power diesel generator stopped due to fuel starvation (operator error).
- Turbine randomly "hunts" for new level during ramp (air and foam).

Tuesday, 10/30/84. Utility team training—system operation.

- Team operated system and synchronized to grid 2 hr. 17 min. (901 kW maximum).
- Performed two turbine overspeed tests (1285 RPM trip), flow performed.
- Olin loop valved out due to salt leak.
- Three-way water diverting valve thru spray water heat exchanger leaks thru SW heat exchange (20% power output loss).

Wednesday, 10/31/84. Utility team training—system operation.

- Team operated system and synchronized to grid 1 hr. 35 min.
- High turbine back pressure (9") caused high turbine exhaust temperature (109°F); steam seal valves adjusted.
- Hot salt sump level transmitter erratic due to plugged vent.
- Shut down early due to salt leak from hot tank control valve (FCV-221).

Thursday, 11/1/84. No testing; utility team debriefing.

- Team evaluation of training class and MSEE.
- Team debriefing of MSEE.
- Replaced packing in FCV-221.

Friday, 11/2/84. Utility team training—Solar One.

- Team participated in tour of Solar One.
- Installed three freeze protection boxes on SGS; sight glass, FCV-411 and FCV-491.

Monday, 11/5/84. Team #4 training—overview.

- System overview, master control system and classroom training.
- Replaced sight glass in SGS.
- Trace heater for drain valves FCV-184/185 failed; redundant activated.
- SGS chemical feed pump failed; discharge plug blew out.

Tuesday, 11/6/84. Team #4 training—receiver and thermal storage.

- Team received receiver and TSS training and performed control room exercises with cold flow from cold sump to cold tank only.
  - Install new salt flow transmitter (FT-101) to receiver inlet (will activate software and calibrate next week).
  - New feedwater control valve (FCV-411) hooked up (will tune next week).
  - Turbine vibration meter operational.
- Wednesday, 11/7/84. Team #4 training—receiver cold flow.
- Team started and operated receiver in cold flow.
  - CRTF precharged hot tank to 750°F.
  - Deaerator relief valve, RV-431, vented and emptied deaerator; caused by one deaerator heater not automatically shutting down upon reaching set point. CRTF to troubleshoot heater circuit.
  - EPS tripped twice on low boost pump pressure (faulty trip).

Thursday, 11/8/84. Team #4 training—receiver cold/hot flow.

- Team started and operated receiver in cold and hot flow.
- Rewired EPS boost pump pressure trip through spare A-D converter; checkout successful.
- Control valve from cold tank (FCV-201) is only opening 50%; positioner pneumatics does not vent.

Friday, 11/9/84. Team #4 training—receiver hot flow and simulated clouds.

- Team aborted receiver start-up due to high winds, gusts to 45 MPH; team drained hot tank.
- Initiated repair of FCV-201.

Monday, 11/12/84. Team #4 training—SGS training.

- Team training on SGS with control room exercises.
- Redundant trace heater on receiver drain valves FCV-180/181 failed. Previously repaired primary heater activated.
- Replaced positioner on cold salt tank control valve, FCV-201.

Tuesday, 11/13/84. Team #4 training—SGS operation.

- Team operated SGS in hot flow.
- Level sight glass in SGS leaks; valved out.
- Inspected Olin loop; leak at fitting between top two boxes, west end. Tightened fitting and reinsulated line.

Wednesday, 11/14/84. Team #4 training—EPGS.

- Team training on EPGS.
- Team operated SGS in hot flow.
- Team operated EPGS and synchronized to grid for 24 minutes.
- Olin loop operational.

Thursday, 11/15/84. Team #4 training—system operations.

- Team operated system and synchronized to grid for 2 hrs, 11 min.
- Started installation of feed water pump suction pressure switch.
- Solar One Advisory Committee Meeting at CRTF.

Friday, 11/16/84. Team #4 training—SGS/EPGS and debriefing.

- Team operated SGS and EPGS and synchronized to grid for 1 hours.
- Team evaluation of training class and MSEE.
- Team debriefing of MSEE.

Daily Activity - 11/19/84 - 11/23/84.

- Receiver Subsystem (No maintenance)

- TSS

1. Reinstalled lagging on cold tank control valve (FCV-201).

- SGS

1. Installed metal section of sight glass in level indicator.
2. Insulated line above sight glass.
3. Insulated steam attenuator valve (FCV-331).

- HRFS

1. Calibrated and installed feed water pump low pressure switch on suction side.
2. Installed wiring for micros to deaerator heaters.

- EPGS

1. Installed hot well temperature element (TE-580).
2. Installed shock absorber on steam pressure transmitter (PT-581).

Monday, 11/26/84. Team #5 training—overview.

- System overview, master control system and classroom training.
- Boost pump bypass line flanges are rated at 150 psi with pump outlet pressure at 320 psi.
- Rewired feed water pump suction pressure switch (PS-481).

Tuesday, 11/27/84. Team #5 training—receiver and thermal storage.

- Team received receiver and TSS training and performed control room exercises with cold flow from cold sump to cold tank only.
- Boost pump pressure transmitter for the equipment protection system (PT-180A) drifts during start-up and trips heliostats.
- Repaired SGS chemical feed pump.
- SGS steam drum level transmitter (LT-311) froze and tripped SGS off diurnal shutdown.

Wednesday, 11/29/84. Team #5 training—receiver and SGS (no solar).

- Team training on SGS.
- Acurex down due to faulty power supply that damaged the analog control board. Replaced board; temporarily connected two external power supplies.
- Checked warm-up of receiver panel with 75% of field at 100 w/m<sup>2</sup>. Center of panel warms up more rapidly than edges.

Thursday, 11/29/84. Team #5 training—receiver cold/hot flow.

- Team started and operated receiver in cold and hot flow.
- Team precharged and charged hot tank.
- Control valve to hot tank (FCV-161) erratic.
- PT-180A still variable during start-up.

Friday, 11/30/84. Team #5 training—SGS training.

- CRTF charged hot tank using propane heater.
- CRTF checked out EMCON interlocks; hot surge tank level (LT-161), cold sump level (LT-201), and hot sump level (LT-221).
- Team training on SGS.
- Team performed SGS pretest checklist in control room.

Monday, 12/3/84. Team #5 training—EPGS training.

- Team training on EPGS.
- DEC computer failure prevented operation of EMCON.
- Implemented repair on DEC computer.
- Removed positioner off control valve to propane heater for warranty repair.

Tuesday, 12/4/84. Team #5 training—SGS/EPGS (snow/windy, no testing).

- Team training on SGS and EPGS.
- Cold SGS temperatures prevented operation.
- Cold propane heater outlet prevented operation.

Wednesday, 12/5/84. Team #5 training—SGS/receiver operation.

- Team operated SGS in hot flow.
- Team operated receiver in hot flow with clouds.
- Boost pump stopped during receiver operation without being commanded.
- Feed water pump failed.

Thursday, 12/6/84. Team #5 training—MSEE debriefing.

- Team evaluation of training class and MSEE.
- Team debriefing of MSEE.
- Feed water pump sustained extensive damage; requires factory repair.
- CRTF charged hot tank using receiver.

Friday, 12/7/84. Heliostat efficiency tests.

- Tested 48 aligned/non-aligned heliostats for efficiency.
- Continued inspection and assessment of feed water pump.
- Started 8-hour work days.
- Started Receiver Thermal Conditioning Tests.

Monday, 12/10/84. Heliostat efficiency tests.

- Tested 48 aligned/non-aligned heliostats for efficiency.
- Aligned 11 heliostats.
- Shipped feed water pump to Ingersol Rand for repair.

Tuesday, 12/11/84. No solar, no testing.

- Removed insulation and tightened packing on cold tank control valve.
- Tested and determined flow rate from hot sump to cold sump via one-inch transfer line to be 27k#/hr; this results in approximately 6 hours to empty the hot tank.
- Charged hot tank using propane heater.



Wednesday, 12/12/84. Poor solar, windy, no testing.

- Reinsulated cold tank control valve (FCV-201).
- Added water to SGS to maintain diurnal shutdown.

Thursday, 12/13/84. No solar, snow, windy, no testing.

- Pumped 30 inches of salt into cold tank via hot sump.
- Cold tank control valve (FCV-201) positioner failed.
- Removed FCV-201 positioner for troubleshooting.

Friday, 12/14/84. No solar, snow, windy, no testing.

- Repaired FCV-201 positioner.
- Gravity drained additional salt to cold tank.

Daily Activity - 12/17/84 - 12/21/84.

- Receiver Subsystem

1. Performed receiver loss tests with cavity door open and closed.

- TSS

1. Transferred salt from hot tank to cold tank; salt leak from boost sump.
2. Determined leak in boost sump through gasket between pump and to plate.
3. Salt leak from cold tank control valve (FCV-201).

- SGS

1. Aborted SGS loss tests due to frozen steam lines; could not drain superheater of condensate.

- HRFS

1. Verified feed water pump motor integrity by meggering.

- System

1. Secured all subsystems for holidays.

WEEK ENDING 01/04/85

- RECEIVER SUBSYSTEM

1. Protection from heliostat beams installed on north side
2. Started trace heater replacement on drain valves; all drain valves exposed and four heaters fabricated
3. Evidence of salt leak around most drain valves

- TSS

1. Additional testing verified leak in boost sump thru gasket between pump and top plate
2. Angle to be welded around top plate to contain leakage
3. Inspected inside boost sump through fabricated opening; no anomalies

- SGS

1. Continuing nitrogen purge of SGS

- HRFS

1. Preliminary evaluation of feedwater pump indicates inadequate lubrication of bearing
2. Feedwater pump may be shipped as early as 1/18/85

WEEK ENDING 01/11/85

- RECEIVER SUBSYSTEM

1. Reinstalled drain valve FCV-187; water leak tested bellows
2. Installed trace heaters on all drain valves; ready for reinsulation
3. Checked absorptivity of panel; preliminary results indicate slight degradation

- TSS

1. Reinsulated boost sump
2. Fabricated and installed two new trace heaters on boost sump drain line
3. Scheduled to checkout boost sump next week

- SGS

1. Continuing nitrogen purge of SGS

- HRFS

1. Final evaluation of feedwater pump indicates inadequate lubrication of outer bearing started feedwater pump failure
2. Test ran feedwater pump and measured current within spec
3. Rewired spray water pump starter control to prohibit pump start with low level in dearator

WEEK ENDING 01/18/85

- RECEIVER SUBSYSTEM

1. Reinsulated drain valves except for final layer
2. Tightened all drain valve bonnets
3. Verified lower header trace heaters has two spares
4. Developing trace heater repair technique on purge valves

- TSS

1. Checked out boost sump/pump; no leaks

- SGS

1. Continuing nitrogen purge of SGS

- HRFS

1. Relocated feedwater pump air cooler outside pump room
2. Discussed feedwater pump startup/operation logic for new pump

- MCS

1. Completed Emcon software updates
2. Replaced Faulty Acurex card that resulted in negative trace heater readings on receiver valves

- HELIOSTATS

1. Aligned 11 heliostats this week; (150 aligned)

WEEK ENDING 01/25/85

- RECEIVER SUBSYSTEM

1. Reinsulated all drain valves
2. Reinsulated lower header
3. Repaired three of four purge valve trace heaters; FCV-191 remain to be replaced

- TSS

1. Redundant heater on boost sump failed
2. Relocated boost sump bypass line directly to cold sump with 600 pound flanges in place of the 150 pound flanges
3. Found a sheared bolt head on top of the boost sump with frozen salt locally; will weld shut
4. Two four inch valves for the new cold tank line were shipped

- SGS

1. Continuing nitrogen purge of SGS

- HRFS

1. Feedwater pump to be shipped 1/19
2. Installed new bushing into feedwater pump housing
3. Added missing jumper to back of PCM #2 which resolved the ground reference anomaly

- HELIOSTATS

1. No solar Monday-Thursday; aligned 4 heliostats Friday; (154 aligned)

WEEK ENDING 02/01/85

- RECEIVER SUBSYSTEM

1. Minor effort due to inclement weather

- TSS

1. Replaced boost sump trace heaters and reinsulated sump
2. Two four inch valves for the new cold tank line at CRTF
3. Charged hot tank; emptied cold tank completely in preparation for line replacement
4. Cold pump cavitates at 20 inches; should cavitate at 11 inches

- SGS

1. Continuing nitrogen purge of SGS
2. Formulating a plan to repair/replace failed trace heaters

- HRFS

1. Feedwater pump shipped 1/30

- HELIOSTATS

1. No solar all week (154 aligned)

- MASTER CONTROL SYSTEMS

1. Net-90 again operational with repaired cards
2. Acurex CRT failed and was repaired

WEEK ENDING 02/08/85

- RECEIVER SUBSYSTEM

1. Replaced purge valve trace heater
2. Reinsulated purge valves, ready for checkout

- TSS

1. Removed cold tank line from cold tank to cold sump
2. Installed new four-inch control valve at cold tank
3. Replacement of cold tank line on schedule

- SGS

1. Continued nitrogen purge of SGS

- HRFS

1. Feedwater pump at CRTF

- HELIOSTATS

1. No alignment effort

WEEK ENDING 02/15/85

- RECEIVER SUBSYSTEM

1. Refurbishment completed, monitoring temperatures
2. Removed protective shield off top of tower

- TSS

1. Completed cold tank line from cold tank to cold sump
2. Installed trace heaters on new line and valves
3. Insulation of new line to be completed next week

- SGS

1. Continuing nitrogen purge of SGS

- HRFS

1. Installed feedwater pump
2. Rewired feedwater pump logic
3. Repaired spray water heat exchanger diverting valve (FCV-432)

- HELIOSTATS

1. Aligned 19 heliostats (1173 aligned)



WEEK ENDING 02/22/85

- RECEIVER SUBSYSTEM

1. Refurbishment completed, monitoring temperatures

- TSS

1. Completed and checked out cold tank line from cold tank to cold sump
2. Leak in boost sump, location not determined
3. Started reinsulation of outlet to boost pump, salt leak at pressure transmitter flanges

- SGS

1. Continued nitrogen purge of SGS
2. One of three SGS trace heaters has additional redundant heater
3. Heater 5 cannot be repaired

- HRFS

1. Feedwater pump coupling at CRTF

- HELIOSTATS

1. Aligned 3 heliostats (176 aligned)

WEEK ENDING 03/01/85

- RECEIVER SUBSYSTEM

1. Panel thermocouple TE148 failed

- TSS

1. Completed reinsulation of outlet to boost pump
2. Boost sump trace heater failed at cold/hot transition; successfully repaired

- SGS

1. Continued nitrogen purge of SGS
2. Continued to effect repairs of last redundant trace heater

- HRFS

1. Feedwater pump motor bearings determined faulty by outside alignment contractor
2. Replaced feedwater pump motor bearings

- HELIOSTATS

1. Aligned 2 heliostats (178 aligned)
2. Heliostat computer failed

WEEK ENDING 03/08/85

- RECEIVER SUBSYSTEM

1. Operated receiver at 800°F set point
2. Performed preliminary calibration of flow meter to receiver (FT-101)

- TSS

1. Precharged hot tank with 780°F salt
2. Tuned cold sump level control valve (FCV-201)

- SGS

1. Started cleaning (flushing) SGS in preparation for testing.
2. Continued to effect repairs of last redundant trace heater

- HRFS

1. Aligned feedwater pump motor with pump
2. Completed feedwater pump plumbing

- HELIOSTATS

1. Aligned 0 heliostats (178 aligned)
2. Heliostat HP computer failed

WEEK ENDING 03/15/85

- RECEIVER SUBSYSTEM

1. Installed positive latches on purge valve doors and sealed doors

- TSS

1. Boost pump seized up-minimum two week to repair
2. Isolated cold sump from boost sump; capped salt lines
3. Reinsulated FCV-242 outlet from propane heater

- SGS

1. Operated SGS in cold flow
2. Performed thermal loss tests
3. Completed repairs of last redundant trace heater; one heater without spare

- HRFS

1. Operated FWP with complete subsystem
2. Verified FWP hot alignment within spec
3. Verified three way diverting valve (FCV-432) does not leak

- HELIOSTATS

1. Aligned 0 heliostats (178 aligned)
2. Heliostat MODCOMP computer failed "head crash", and repaired

WEEK ENDING 03/22/85

- RECEIVER SUBSYSTEM

1. No testing due to boost pump out of service

- TSS

1. Removed boost pump, one of two lower bearings damaged (repair and reinstallation scheduled for completion on 3/29/85)
2. Installed new trace heater on 3 foot section of uninsulated line on outlet of propane heater
3. Cold pump cavitates at 10.5 inches instead of 20. The salt recirculation line is causing the early cavitation

- SGS

1. Operated SGS in cold and hot flow
2. Verified auto ramp up and ramp down sequences

- HRFS

1. Replumbed FWP cooling to only domestic water (simplifies operations)

- HELIOSTATS

1. Aligned 0 heliostats (178 aligned)
2. Developed preliminary early warmup pattern

WEEK ENDING 03/29/85

- RECEIVER SUBSYSTEM

1. No testing due to boost pump out of service

- TSS

1. Completed boost sump/pump installation
2. Reinstalled trace heaters on boost pump piping
3. Reinsulated boost sump pumping

- SGS

1. Operated SGS in cold and hot flow
2. Verified auto ramp up and ramp down sequences

- EPGS

1. Synchronized to grid for 1 hr 15 minutes; verified turbine/generator integrity

- HELIOSTATS

1. Aligned 0 heliostats (178 aligned)
2. Developed preliminary early warmup pattern

WEEK ENDING 04/05/85

- Monday, 4/1/85 - Receiver early startup development
  - Operated boost pump and verified integrity subsequent to removal of loose bolt inside motor housing
  - Temporary salt blockage in lower header during receiver rill
  
- Tuesday, 4/2/85 - Full system early startup development
  - Receiver panel temperatures ready for receiver startup at 06:57
  - Receiver panel back tube thermocouples TE-104, 106 & 110 erratic; control algorithm could not control receiver with steady insolation
  - Synchronized to grid with full system for 26 minutes
  - During turbine/generator ramp up, output oscillated between 70 and 960 KW
  
- Wednesday, 4/3/85 - Receiver operation
  - Reattached receiver panel back tube thermocouples, TE-104, 106 & 110
  - Operated receiver and verified control algorithm controls receiver properly
  - Could not start up turbine; suspect internal oil pump faulty
  - Phase III Data Team meeting
  
- Thursday, 4/4/85 - Turbine troubleshooting
  - Removed damaged turbine internal oil pump; twisted main shaft, damaged drive gear, seized bearings
  - Installed metal panels on lower header
  - Initiated turbine oil pump repair options
  - Phase III Data Team meeting
  
- Friday, 4/5/85 - Receiver operation
  - Attempted to determine time when receiver produces 950<sup>o</sup>F salt at 20K lbs/hr flow rate
  - Heliostat 'B' West HIM stow
  - Cold tank return control valve (FCV-162) temporarily malfunctioned

WEEK ENDING 04/12/85

- Monday, 4/8/85 - Utility personnel refresher on MSEE
  - Utility personnel briefing in classroom and field tour
  - Approximately 3 gallons of water in 55 gallons of turbine oil
  - Main high speed turbine shaft scored
- Tuesday, 4/9/85 - Receiver and SGS Operation
  - Utility operators operated receiver in cold flow
  - PCM#1 off line; delayed receiver startup
  - Utility operators operated SGS in cold flow
- Wednesday, 4/10/85 - Propane heater operation
  - PCM#1 off line; emergency receiver shutdown during fill
  - SGS heater #5 wiring opened at junction; repaired
  - During propane heater startup, temperature of 1560<sup>o</sup>F was experienced due to unknown restricted flow
- Thursday, 4/11/85 - Propane heater operation
  - Visually inspected inside propane heater, no visual damage
  - Operated propane heater; no anomalies
  - Emcon repaired PCM#1; replaced priority interrupt card
  - Repaired failed Olin loop trace heater; loop operational
- Friday, 4/12/85 - System early morning startup
  - Started operations at 05:30 and demonstrated early startup
  - Started receiver fill at 06:49
  - Started SGS fill at 08:07



WEEK ENDING 04/20/85

- Sunday, 4/14/85 - Start power production (good solar)
  - Sync to grid 8 hr - 13 minutes
  - Started receiver fill at 06:46
  - Sync to grid at 08:47
  
- Monday, 4/15/85 - power production (1067 w/m<sup>2</sup> peak)
  - Sync to grid 6 hr - 32 minutes
  - Started receiver fill at 06:49
  - Sync to grid 07:58
  - Receiver drain valve FCV-180 leaks through
  
- Tuesday, 4/16/85 - power production (partial solar)
  - Sync to grid 2 hr - 52 minutes
  - Temporary partial salt blockage in lower header (two passes)
  - Main SGS system outlet valve FCV-491 leaks water
  
- Wednesday, 4/17/85 - power production (early clouds)
  - Sync to grid 5 hr - 14 minutes
  - Added insulation to lower header inside cavity
  - Temporary partial salt blockage in lower header (one pass)
  
- Thursday, 4/18/85 - power production (partial solar)
  - Sync to grid 5 hr - 18 minutes
  - Olin loop not operational (frozen salt)
  - High winds (50 mph) late in afternoon
  
- Friday, 4/19/85 - power production (no solar)
  - Did not sync to grid
  - Manually locked closed receiver drain valve FCV-180
  - Added additional insulation to lower header inside cavity
  
- Saturday, 4/20/85 - power production (best day)
  - Sync to grid 9 hr - 7 minutes
  - Main SGS steam outlet valve leaks superheated steam

WEEK ENDING 04/27/85

- Sunday, 4/21/85 - power production (no solar)
  - Did not sync to grid
  - HRFS cycle fill pump discharge union failed
- Monday, 4/22/85 - power production (no solar - rain)
  - Did not sync to grid
  - Replaced faulty union on discharge of cycle fill pump
  - Replaced bonnet gasket on main SGS steam valve (FCV-491)
- Tuesday, 4/23/85 - power production (good solar; 1074 w/m<sup>2</sup> max)
  - Sync to grid 4 hr - 12 minutes
  - Temporary salt blockage in lower header; 3 hour delay
  - Emcon right console erratic; random graphics appear
- Wednesday, 4-24/85 - power production (good solar)
  - Sync to grid 10 hr - 34 minutes
  - Emcon repairman replaced display generator card and central processing unit card which corrected erratic console
- Thursday, 4/25/85 - power production (partial solar)
  - Sync to grid 2 hr - 43 minutes
  - Water leak at HRFS discharge from spray water heat exchanger valve (HV-450)
  - Oil leak from feedwater pump to cooling water
- Friday, 4/26/85 - power production (partial solar)
  - Did not sync to grid
  - Temporary salt blockage in lower header; 30 minute delay
  - Charged hot tank to 800°F
- Saturday, 4/27/85 - power production (no solar - windy)
  - Did not sync to grid
  - Verified faulty heater in Olin Loop (Olin Loop not operational)
  - Repaired spray water heat exchanger valve (HV-450)

WEEK ENDING 05/04/85

- Sunday, 4/28/85 - power production (no solar - rain)
  - Did not sync to grid
  - No operations due to rain
- Monday, 4/29/85 - power production (no solar - rain until 14:00)
  - Did not sync to grid
  - Reterminated SGS recirculation wires
  - Charged hot tank using receiver to 871<sup>o</sup>F @ 133"
- Tuesday, 4/30/85 - power production
  - Sync to grid 9 hr - 20 minutes
  - Heliostat diesel generator #2 failed (requires overhaul)
  - FWP pressure control valve (FCV-401) leaks, cannot maintain SGS at full load; derated SGS 10%
- Wednesday, 5/1/85 - power production
  - Sync to grid 6 hr - 6 minutes
  - Receiver fill at 10:21 (3 hr late) due to cold lower header
  - Scramed heliostats at 16:20 due to no solar
- Thursday, 5/2/85 - power production (partial solar)
  - Sync to grid 4 hr - 11 minutes
  - Acurex tape malfunctioned; replaced tape
- Friday 5/3/85 - power production
  - Sync to grid 10 hr - 52 minutes on 13 hr - 15 minute day
  - Lost feedwater pump pressure twice for less than five minutes
  - FWP pressure control valve (FCV-401) still leaks
- Saturday, 5/4/85 - power production (partial solar)
  - Did not sync to grid (SGS drain valves trace heaters failed)
  - Repaired SGS drain valves (FCV-381/382) trace heaters (all SGS heaters have redundant circuits)
  - Charged hot tank using receiver

WEEK ENDING - 05/11/85

- Sunday, 5/5/85 - power production (partial solar)
  - Synchronized to grid 7 hrs, 28 min
  - No solar at 1430, shutdown all subsystems
- Monday, 5/6/85 - power production (partial solar)
  - Synchronized to grid 7 hrs, 31 min
  - No solar at 1520
- Tuesday, 5/7/85 - power production (partial solar)
  - Synchronized to grid 6 hrs, 57 min
  - Clouds throughout operations from 1100
- Wednesday, 5/8/85 - power production
  - Synchronized to grid 10 hrs, 48 min
  - Cold sump vent blocked twice with frozen salt
- Thursday, 5/9/85 - power production (partial solar)
  - Synchronized to grid 3 hrs, 21 min
  - Cold sump vent blocked three times with frozen salt
  - Main SGS steam outlet valve (FCV-491) leaks steam
- Friday, 5/10/85, power production (partial solar)
  - Synchronized to grid 4 hrs, 35 min
  - High winds (40-45 mph) hampered operations
- Saturday, 5/11/85 - power production (last day)
  - Synchronized to grid 9 hrs, 31 min on 13 hr, 25 min day
  - Added additional insulation inside cavity lower header
  - Cold salt pump leaks (spray) at housing

ADDENDUM E  
RELIABILITY AUDIT

MEMORANDUM

To: Bill Delameter, SNLL-8453 and Ed DeMeo, EPRI  
From: John Holmes, SNLA-6222 and Dick Holl, MDAC  
Subject: MSEE Reliability Review and Recommendations

A reliability audit of the MSEE was conducted by MDAC and the CRTF with an in-depth review held with representatives of MMC, B&W, B&V and PNM. The major findings of this review and the resulting recommendation are given below.

Objective

Recommend a maintenance program to achieve the following system availability targets:

0.5 for test program from June - August.

0.75 for utility operation from September - November.

The cost trade factor for system availability is \$100K per month. This is based on the incremental cost of operating the MSEE and conducting the test program.

The reliability review was conducted in the four phases summarized below.

Survey -- April 9 - April 17

A detailed listing was made of every component of the MSEE, including all instrumentation. Individual interviews were conducted with all members of the CRTF staff associated with MSEE and with the major equipment suppliers. The following information was tabulated for each component:

- o Critical for MSEE operation?
- o Past problems
- o Present status
- o Spares status (where available)

In addition, any other suggestions to improve equipment availability were solicited.

During this same period, a physical inventory of spare parts for the MSEE was prepared by John Holmes.

The detailed audit (21 pages) is available for review at the CRTF. It was used to prepare a "short list" for detailed review during the next phase.

Detailed Review -- April 18 - April 20

A detailed review of MSEE reliability by subsystem was conducted and potential improvements were discussed. The review committees, the subsystems reviewed and the dates are given on Attachment I. The format for these reviews together with the discussion leaders are shown on Attachment II. The material reviewed, including that added at the meetings, is given in Attachments III and IV. Attachment III reviews past problems and present status by subsystem and component category; it is the "short list" developed from the preceding survey. Attachment IV covers potential problems, possible actions and recommendations from the committees.

A set of action items needed to complete the reliability assessment and implement the EPS recommendations was prepared. They are given as Attachment V.

Action Items -- April 23 - April 30

The action items listed in Attachment V were completed sufficiently to prepare the reliability recommendations. The balance will be finished as required to implement the recommended program.

Recommendations for Reliability Improvement of MSEE -- May 1 - May 4

A set of recommendations to improve the reliability of MSEE was prepared by John Holmes. These were reviewed and agreed with by Dick Holl. These recommendations are submitted as Attachment VI.

Other documentation of this review activity is available at the CRTF. The undersigned will be happy to discuss any aspect in greater detail.

John Holmes  
SNLA-6222

*6-27-84 2-66*  
Dick Holl  
MDAC

RJH/ad

Attachments: As Noted

## MSEE RELIABILITY REVIEW

## CRTF

Wed., April 18, 1984 9:00 am - 4:30 pm	Receiver (RS) Thermal Storage (TSS) Steam Generator (SGS) - Salt Side	Marty Brezeczek (MMC) George Grant (B&W) John Holmes (CRTF) Tom McKeown (MDAC) Dick Holl (MDAC) Ralph Dowling (B&W) Larry Clark (MMC)
Thur., April 19, 1984 9:00 am - 4:30 pm	Steam Generator (SGS) Heat Rejection & Feedwater (HRFS) Electric Power Generation (EPGS)	George Grant (B&W) Gene Moller (B&V) Rich Crane (PNM) John Holmes (CRTF) Tom McKeown (MDAC) Dick Holl (MDAC) Ralph Dowling (B&W) Larry Clark (MMC) Larry Nelson (SR)
Fri., April 20, 1984 9:00 am - 4:00 pm	Master Control (MCS) Equipment Protection (EPS) Heliostats (CS)	John Holmes (CRTF) Roger Aden (CRTF) Larry Clark (MMC) Dick Holl (MDAC) Tom McKeown (MDAC)



## DISCUSSION LEADERS

	RS & TSS	SGS	HRFS	EPGS	MCS	EPS	HELIO- STATS
Subsystem Description	Tom McKeown	Tom McKeown	Tom McKeown	Tom McKeown	Roger Aden	Larry Clark	John Holmes
Operations	Tom McKeown	Tom McKeown	Tom McKeown	Tom McKeown	-	-	-
Equipment Protection Subsystem Functions	Larry Clark	Larry Clark	Larry Clark	Larry Clark	Larry Clark	Larry Clark	-
Past Problems - Present Status	Larry Clark	Ralph Dowling	John Holmes	Larry Nelson	Roger Aden	Larry Clark	John Holmes
Potential Problem Review	Dick Holl	Dick Holl	Dick Holl	Dick Holl	Roger Aden	Larry Clark	John Holmes
Summary of Recommendations	John Holmes	John Holmes	John Holmes	John Holmes	John Holmes	John Holmes	John Holmes

## Attachment III

## Review of Past Problems and Present Status of MSEE

<u>Component Category</u>	<u>Past Problems</u>	<u>Present Status</u>
RECEIVER AND THERMAL STORAGE SUBSYSTEM		
Absorber	None	OK
Housing	Beam spillage scorched paint	OK
Door	Beam spillage burned control wires, motor overdrove and damaged brackets and burned out motor	OK
	Microswitches failed	OK
Pipes	Vibration during RS drain	Changed procedure, OK
	Vibration during TSS operation	Changed procedure, OK
	Cold spots at fixed points	OK
	Gaskets	OK
	Pipe hangers	OK
Pumps	Booster pump packing leaks and freezing	Rebuilt; OK
	Pumps cavitated during operation	Continuing
	Cold pump not spinning down properly	Greased bearing, OK
	Boost pump bypass orifice undersized	Remains
Valves	FCV-101, FCV-102, FCV-151 actuator problems	Rebuilt, OK
	Drain and purge valves had wrong gaskets	Replaced; OK
	FCV-211 bent shaft	Doesn't close properly
	FCV-231 bellows leaked	Replaced; OK
	FCV-201, FCV-211, FCV-221 leak by	Remains
Insulation & wind protection	All valves become cold in high winds	Reinsulated; some lose heat in winds greater than 20-30 mph
	Access difficult in many areas, particularly purge valves	

## Attachment III

## Review of Past Problems and Present Status of MSEE

<u>Component Category</u>	<u>Past Problems</u>	<u>Present Status</u>
RECEIVER AND THERMAL STORAGE SUBSYSTEM (Continued)		
Heat trace	Changed to active control	OK
	Lost 7 heaters	Running on backups, repairing where possible
Instrumentation	Temperature sensors (62)	
	- Replaced slow TCs for control (18)	OK
	- Header #5 TE-188 reads low	-
	- Booster pump bearing TC lifted	Reattached; OK
	Pressure sensors	
	- No problems	OK
	Level sensors	
- LT-151 freezing, leaking gaskets, calibration	Insulated, changed gaskets Out of calib.	
- All others - None	OK	
	Valve ZTs will not stay in calibration	Out of calibration
	Flow sensors	
calibration	Out of calibration	- FT-101 freezing, out of
	Flux gages	
	-	- 1 - bracket problem
Replaced		- 1 - burnt out
Check out		- 2 - electrical problems
	Valve position indicators	
Out of calibration		- Go out of calibration
Propane heater	Will not control temperature under main flame without salt	Continues
	Minor explosion due to flame-out	OK; wind shields added
Tanks	Heaters in hot salt storage burned out	Remains
	Line to cold sump undersized for rated operation	Remains
	Salt spills from hot surge tank, cold sump and hot sump	Procedures corrected
Electrical supply	Tripped tower breaker; burned out power supply wiring	Not sized for full system capacity

## Attachment III

## Review of Past Problems and Present Status of MSEE

<u>Component Category</u>	<u>Past Problems</u>	<u>Present Status</u>
STEAM GENERATOR SUBSYSTEM		
Valves	3 had assembly problems	Reworked; OK
	All have some thermal loss problems	Reinsulated, windshields added
	FCV-384 I-to-P problems	Problem remains I-to-P
	Pressure relief valve PSV-381 Needs to be rebuilt after every lift and reset	OK
Piping	None	OK
Heat exchangers	None	OK
Pumps	Boiler water circ. pump (BWCP) broke bearings, shorted stator. Running backwards.	OK
	Cavitated hot salt pump often	OK
	Chemical feed pump. Phosphates settle out	Continuing problem
	BWCP thermal switch is bad	Remains
Instrumentation	Temperature sensors - none (TE-332 & -331 leaked)	OK
	Pressure sensors - all froze on water side	Heat tracing & insulation; OK
	Flow sensors - calib.	Recalib.; OK
	Level sensor - freezing, leaking	Rework; OK
Heat trace	Lost one circuit	Running on backup; OK
	Added instrument circuits - none	OK
Electrical heater	Burned out elements twice	OK
	Pressure vessel ruptured	OK
	Heater was wet when arrived on site	OK

## Attachment III

## Review of Past Problems and Present Status of MSEE

<u>Component Category</u>	<u>Past Problems</u>	<u>Present Status</u>
HEAT REJECTION AND FEEDWATER SUBSYSTEM		
Valves	FCV-401 cracked rim	OK
	FCV-411 positioner drifting	OK; leaks by
	FCV-421 flow rate inadequate	Replace plug & trim
	FCV-431 none	OK
	FCV-432 leaked by	OK
	FCV-471 cracked plug	Rework
	FCV-483 orifice clogs	-
	FCV-491 changed to flow control	OK
	All others - none	OK
Piping	None	OK
Heat exchangers	Spray water - gasket blowout	OK; small leak
	Feedwater - not rated output	~460°F; rated 550°F
	DA - none	OK
Pumps	Feedwater - cavitation; poor warmup	OK; changed procedure
	Spray water - leaky O-rings	OK; minor leak
	Chem. feed pump. Plugged check valve	OK
	Condensate makeup - replaced motor w/larger motor	OK
	Cycle fill - loses prime	Replacing
Instrumentation	Temperature sensors	
	- Cooling water TE-484	Out of calibration
	- Balance - none	OK
	Pressure sensors	
	- PT-482 freezing	Needs constant venting
	- Balance - none	OK
	Flow sensors	
	- FT-481	Does not read
	- FT-482 - out of calibration	Out of calibration
	FT-411 needs const. bleeding	?
	Level sensors - none	OK
Heaters	Replaced DA heaters after chem. clean	OK
Cooling tower fans	Bank #11 stopped running during system operation	Heaters undersized on motor contactors
	2 running backwards	OK

## Attachment III

## Review of Past Problems and Present Status of MSEE

<u>Component Category</u>	<u>Past Problems</u>	<u>Present Status</u>
ELECTRIC POWER GENERATION SUBSYSTEM		
Turbine	5 steam seals don't work	Don't work
Generator	Brushes not seating, wired wrong	OK
Excitor	Amplidyne did not work	Not used
	Solid state wired per catalog (wrong)	OK
Reverse power relay	Possible wiring problem	Working on problem
Reduction Gear	Oil foaming	Continues
	Small oil leaks	Working on them
Valves	None - calib	OK; recalib
Piping	None	OK
Pumps	None	OK
Heaters	None	OK
Instrumentation	Temperature sensors - none	OK
	Pressure sensors	
	- PT-582	Does not read
	- Balance of sensors - none	OK
	Level sensor - LT-511, installation	OK
	Turbine oil	
	- Flow sensors - didn't work	NA
	- Synchroscope - 2 working in opposite directions	OK
	- Voltage - none	OK
	- Current - none	OK
- Power		
- VARS		
- Frequency - calib.	Cal.	
- Speed - calib.	Cal.	
- Vibration - none	OK	
- Pressure indicator PI-581	Not reading	

## Attachment III

## Review of Past Problems and Present Status of MSEE

<u>Component Category</u>	<u>Past Problems</u>	<u>Present Status</u>
MASTER CONTROL SUBSYSTEM		
EMCON D-2		
PCM-1	Back plane card shorted	OK
	μP card went out	Software overload
PCM-2	Ambient sensor card (static elect.)	OK
	Power dropouts	No line conditioner
PCM-3	Lost analog cards	OK
	Lost a digital card	OK
	Noise spike stalled μP	Line conditioner; OK
Operator consoles	Arcade mode	Still present
	1 memory cell bad	Still present
	Can copy screen from only one CRT	Still present
Host computer	None	OK
Line typers	Lost a head decoder	OK
Disk drives	Storage space, superfluous software	OK
Communication	Noise	Needs a line conditioner
Control signals	Dual signals required; contributed to incidents	Still required
Signal		
Network-90		
Operator consol	Replaced CRT, moved to control room	OK
Termination unit	2 burned out cards, replaced/reworked	OK
Power supplies	One went bad	OK
PCU	Slave module went bad	OK
	Diodes went bad	OK
OIU	Lost a Winchester drive	OK
Acurex	Gets lost sometimes	OK
HP	Head crash	OK
	Lost a I/O card to MODCOMP system	OK

Attachment IV

Potential Problems and Possible Actions

<u>Component</u>	<u>Potential Problem</u>	<u>Possible Action</u>	<u>Recommendation</u>
RECEIVER AND THERMAL STORAGE			
Heat trace	Headers had 8 installed - need 4, 6 remain	None	Review MMC data on dead band impact (on 5/9)
	19 drain & purge valves had redundant heaters installed; 3 have failed	Repair 3 failed junctions Order spares for backup Spare for Line 12	Yes Yes Yes
	Variable temps - during winds	Add more active control loops	No
Boost pump	Bearings and leakage	Spares	Yes
Cold pump	Bearings	Spares	Yes
Line No. 16	Vibrations	Install vibration dampeners	Yes
Wind protection			
- Tower top	Components cold following winds	Design and install wind shields; Include FCV-101, -102 and FT-101	Yes
- Top of hot tank	Components cold following winds	Design and install wind shields;	Yes



## Attachment IV

## Potential Problems and Possible Actions

<u>Component</u>	<u>Potential Problem</u>	<u>Possible Action</u>	<u>Recommendation</u>
RECEIVER AND THERMAL STORAGE (Continued)			
Propane heater	Fuel control anomaly	Diagnose and repair	Yes
	Manual control could overheat salt; requires constant monitoring	Add control loop (add outlet TC and hookup to EMCON)	Yes
Valves			
- FCV-211	Bent shaft	Rebuild	Yes
- FCV-152	Plug & seat removed; orifice in line; may be too small	Rebuild Revise procedures or increase orifice	<u>Action items</u> 1. Recalculate flow 2. Check with Lawrence Pur
- FCV-231	Cannot remove seat - welded body	Replace	No
- FCV-161 & -162	High head drop	Rebuild kits	Yes
- FCV-161, -242, -231 & -351	Bellows of SS321	Have spare bellows for all	Yes
- FCV-101 & -102	Actuators	Rebuild kits	Yes
- Balance of remove-operated valves		Rebuild kits and spare positioners	Yes

## Attachment IV

## Potential Problems and Possible Actions

<u>Component</u>	<u>Potential Problem</u>	<u>Possible Action</u>	<u>Recommendation</u>
RECEIVER AND THERMAL STORAGE (Continued)			
Instrumentation	FT-101 calibration changes	Calibrate & recheck periodically	Yes
	LT-101 calibration drifts	Calibrate & recheck periodically	Yes
	PT-180 and PT-181	Provide spares	Yes (one)
	Other	Provide spares	Yes: 1 $\Delta$ P for FT 1 spare bubbler 1 spare pump for flux gages
Cavity housing	Damage to internal insulation	Spare boards	Yes,
	Cold lines	Reinsulate inlet to receiver (FT-101 to inlet)	
		Replacement contactor kits	Are on order
General	Premature wearout	Preventive maintenance program	Action Item

## Attachment IV

## Potential Problems and Possible Actions

<u>Component</u>	<u>Potential Problem</u>	<u>Possible Action</u>	<u>Recommendation</u>
STEAM GENERATION SUBSYSTEM			
Pumps			
BWCP	Ran 6 mos. at high amps.	Spare stator & rotor (\$3600)	Yes, Ralph Dowling to confirm that we have bearing and impeller
Hot salt	Bearings	Spares	Yes
Electrical heater	Failures in past	Spare (\$2800)	Yes
Valves - all	Possible leaks (bellows of FCV-351 covered in TSS)	Rebuild kit for all valves	Yes
		Adaptor for steam drum relief	Yes
Insulation	Heat loss	Add insul. between evaporator and electrical heater	Yes
Heat trace	Two running on backups	Repair and spare	Yes
	FCV-341 using both wires	Spare	Yes, Ralph Dowling provide spec
Wind protection	Cool components	Complete wind screen install.	Yes
Instrumentation	Pump on indication	Current rather than contact for pump on	Yes, also for RS & TSS
	Replacement	Check all spares	Yes
	Freeze protection	Confirm; add to attenuator	Yes
	Recirculation flow	Add transducer in BWCP discharge line	Check cost, Ralph Dowling
	Drum level	Add diaphragm transmitter using silicone oil	No
General	Premature wearout	Provide scheduled maintenance program	Yes, action item

## Attachment IV

## Potential Problems and Possible Actions

<u>Component</u>	<u>Potential Problem</u>	<u>Possible Action</u>	<u>Recommendation</u>
HEAT REJECTION AND FEEDWATER SUBSYSTEM			
Heat exchangers			
- Spray water	Head gasket leaks	Supply of gasket material	None, we have
- Feedwater Heater	Marginal performance	New valve for FCV-421	Yes
		Insulate steam line	Yes
Pumps			
- Feedwater pump	Warmup	Add recirc. pump	Yes, review B&V design
- Spray water pump	Seals	Spare seals & O-rings	Yes
- On signals	No positive indication that pump is running	Install current sensors	Yes
Cooling tower fans	Power overload Bank #11	Checkout & repair	Yes
Valves			
- FCV-471	Has wrong plug	Replace	Yes
- -421	Covered under FWH	Replace	Yes
- -411	Reaction time	Move across bridge	Yes
Steam traps	Undersized or clogging	Replace with proper rating	Yes
Instruments			
- LI-471	Does not stay clean	Get gaskets; clean	Yes
- DOT-480	Not wired to MCS	Wire to MCS	No
-CC-481	Could be running with bad quality water		
-PHT-480			
-Valve positioners	Drifting	Recal.; Rework	Yes
-FT-411	Needs const. bleeding		Move across bridge to just upstream of FCV-411
General	Premature wearout	Provide scheduled maintenance program	Yes, action item

## Attachment IV

## Potential Problems and Possible Actions

<u>Component</u>	<u>Potential Problem</u>	<u>Possible Action</u>	<u>Recommendation</u>
ELECTRIC POWER GENERATION SUBSYSTEM			
Steam seals	No turbine back pressure trip	Repair	Yes
Valves			
- Turbine throttle	Not calib. no positive turbine shutoff	Recal.	Yes
Instrumentation			
-General	Calib. Hookup	Recalib. Check & reconnect	Underway Yes
Generator	Oil leaks	Fix	Yes
	Exciter output	Var. controller on output of exciter	Obtain price
General	Premature wearout	Provide preventive maintenance schedule	Yes, action item

Attachment IV

Potential Problems and Possible Actions

<u>Component</u>	<u>Recommendation</u>
MASTER CONTROL SUBSYSTEM	
EMCON Monitors	Add 2 more monitor screens for utility operation
EMCON Communications	Eliminate dual signals  Pull more spare cables between subsystem and PCM  Recheck all grounds and trouble- shoot elimination of arcade mode
Power supplies	Add UPS and line conditioners on all PCMs and host
EMCON cards	Maintain present inventory as used
Network-90	Determine when warranty expires  Consider eliminating

Attachment IV

Potential Problems and Possible Actions

Component

Recommendation

UTILITIES

Tower power supply	Increase rating to 1500 kW
Circuit breakers	Provide spare components
UPS for receiver valves and 3 EPS cabinets	Check status of loaner now in use
Air supply in tower	Spare parts  Preventive maintenance
TSS building	Add coding fan

Attachment V

Action Item List  
from Reliability Review 4/18 - 4/20/84  
(Continued)

<u>Item</u>	<u>Assigned</u>
<u>Steam Generator (Continued)</u>	
Preventive Maintenance Plan and schedule	Ralph Dowling
Cost estimates for required spares	Ralph Dowling
Capability of steam generator to accept more rapid warmup and cooldown rates	Ralph Dowling (from George Grant)
<u>HRFS</u>	
Preventive Maintenance Plan and schedule	Lindsey Nelson
<u>EPS</u>	
Implement changes:	Larry Clark
Drum level high-high: o Delete: Open generator circuit breaker	
Turbine generator trips: o Add PS531A o Add TE-332A o ADD PT-582A o Delete AZT-581 o Delete TT-483A	
MCS trips: Set steam pressure to turbine trip at 900 psi	
Check impact of shutting FCV-301 instead of tripping turbine for booster pump sump level high	George Grant (through Ralph)



## Attachment VI

### MSEE Reliability Recommendations

#### General Considerations

- Spare Parts
  - Correlate current inventory with requirements
  - Establish inventory record and control system
- Preventive Maintenance
  - Establish PM schedule based on manufacturer's recommendations for all MSEE components
  - Establish record keeping and call-back system
- Instrument Calibration
  - Establish schedule for calibration of all flow, pressure, level transducers and control valve response to MCS commands
  - Recalibrate solar flux gages in the CRTF solar furnace every four months
- Water/Salt Chemistry
  - Perform daily analysis of water quality in the feedwater system and the steam generator. Operate only when within specification.
  - Monitor salt impurity content.
- Configuration Control
  - Enforce MMC recommended configuration control plan. All changes to hardware, software, and procedures will be approved prior to implementation.

#### System Priorities for Action

Based on past experience with MSEE downtime and the present status of the equipment, reliability recommendations will be ordered according to the following priority list. Further rationale for this ordering is given below.

1. CRTF utilities
2. Steam generator
- 3a. Thermal storage and propane heater
- 3b. Heat rejection and feedwater
4. Solar receiver
5. Turbine generator
6. Master control, data & EPS
7. Heliostats

#### Rationale for Priorities

1. CRTF utilities must be available or none of the subsystems can operate. The primary utilities are:
  - Electrical power
  - Instrument air (compressors/driers)
  - UPS for receiver valves and three EPS cabinets
  - Backup instrument air
  - Deionized water
2. The steam generator is the pivotal component of the MSEE. Without it we cannot operate the EPGS or efficiently operate the receiver since it is the only fast heat rejection system we have.
- 3a, b. The thermal storage, propane heater, feedwater and heat rejection systems are vital to the operation of the steam generator. The propane heater must maintain the hot storage tank in event of long periods without sun or without the receiver operable.
4. The solar receiver is considered higher priority than the EPGS because it is the solar-unique part of MSEE.
5. The turbine generator is part of the overall MSEE but is not vital to operation of any of the other subsystems. The steam generator output can be consumed directly by the heat rejection system.
6. The master control, data and EPS are vital to the operation but historically have not prevented desired operation for more than two consecutive days.

7. The heliostats and their controls are vital only to operation of the solar receiver. Historically, about 95 percent of the field is available at all times. Failure of the control computers could cause an acceptable, one-to-two-day delay in receiver operation.

#### Specific Action Recommended for MSEE

These recommendations are listed in the order of priorities discussed above.

#### 1. CRTF Utilities

Electrical - An increase in the size of the CRTF substation is under design, but will not be installed in CY 1984. Operational procedures prevent exceeding the current capacity of the substation. A number of smaller circuit breakers should be backed up with spare parts.

Instrument Air - The TSS/SGS area is served by a dedicated compressor and dryer system. A second compressor of marginal capacity backs up the main compressor. The tower is served by a single compressor and dryer system. A spare for the tower has been procured. All CRTF air compressors are on routine SNL PM programs.

UPS - We use four small uninterruptable power supplies for the EPS and receiver drain valves. A spare supply should be procured. Three additional units should be procured for the PCMs.

Backup Instrument Air - A sufficient inventory of compressed, bottled gas should be in on-site inventory at all times. A specific CRTF operator will be responsible.

Deionized Water - No action required. Deionizer beds are under an on-call service contract.

#### 2. Steam Generator System

SGS Boiler Water Circulation Loop - Both the circulation heater and the canned-rotor circulation pump are required for operation of the SGS. A spare immersion heater and critical components (stator, rotor, impeller) of the pump should be ordered. The pump cooling system should have a complete spare unit, pump and radiator.

SGS Steam Drum Safety Valve - A spare CRTF relief valve will be calibrated for SGS application and used to exchange with the original valve if it develops leak-through conditions. With cooldown and heat-up, this can cause a two-to-three-day test delay.

SGS Valves - All salt valves should have spare stem and bellows assemblies, and complete gasket sets. Wind shields will be installed on all salt valves. Steam valves should have on-site spare gaskets, packing and seat/plug trim sets. Manufacturer's recommendations for spare parts of the electric/pneumatic operators and positioners should be on-site.

SGS I&C - All level, flow, and pressure transducers should have on-site, spare components. Freeze protection shall be implemented on all water systems at the appropriate time of year. N-90 will not have on-site spares. When the N-90 warranty expires, it may be replaced with the EMC process control system if extensive downtime is encountered. Over 90 interconnections will be eliminated and thus overall control reliability should improve.

SGS Steam Traps - The SGS steam traps are marginal for the application. These should be replaced by more conservatively specified traps. This will assure early start-up after overnight system hold.

SGS Trace Heat - Hot-to-cold junction failures will be repaired as possible. The two areas that have unrepairable heating element failures should have two on-site spares. Dual spares will be ordered for other areas only when unrepairable failures are encountered. Operation will be with the redundant heater while the spares are procured. The spares will not be installed until the redundant heater and original heater have both failed and cannot be repaired.

Wind Protection - Wind shielding should be completed for all SGS valves and components to allow the trace heaters to keep temperatures above the salt freezing point under all wind conditions.

### 3a. Thermal Storage System

TSS Salt Pumps - All three salt pumps should have formal PM procedures. Critical spare components for each pump should be on-site. Electric motor burn-out will be dealt with via standing Sandia local maintenance contracts. Melting frozen salt around packing glands shall be controlled only by electric heat rather than by open flame torch application. The pump packing cooling system should have a complete spare unit (pump and radiator) on-site.

TSS Valves - All salt valves should have spare stem and bellows assemblies and complete gasket sets on-site. Manufacturer's recommended spares for the actuators and positioners should be on-site.

TSS I&C - All level, flow, and pressure transducers should have on-site spare components.

TSS Propane Burner - The propane burner fuel supply control unit should have all manufacturer's recommended spare parts on-site. The air blower should receive periodic PM. The three propane evaporators should have one set of recommended spare parts.

TSS Trace Heat - Hot-to-cold junction failures will be repaired as possible. Dual spares will be ordered as soon as one of the two heaters on any area becomes unrepairable. The dual spares will be installed only after the last original heater in an area becomes unrepairable.

TSS Piping - Excessive pipe vibration has been observed on the hot salt line at the inlet to the SGS. This will be reduced by the addition of a shock absorber.

Wind Protection - Wind protection should be provided for all valves and components.

TSS Olin Loop - No recommendations for the Olin loop. If the loop becomes inoperable, it will be isolated for repair.

### 3b. Heat Rejection and Feedwater System

HRFS Pumps - Spare seals, gaskets, packings, impellers or diaphragms and check valves should be procured and available on-site for the feedwater, spraywater, cooling water, cycle fill and the condensate makeup pumps. Motor burnout will be handled locally. Lubrication and other PM will be formalized.

HRFS Valves - All flow and pressure control valves should have spare gasket sets on-site. Replacement trim should be available for all steam control valves. Operators and positioners should have recommended spare components on-site.

In order to achieve improved efficiency from the feedwater heat exchanger, the steam control valve needs to be replaced with a larger capacity valve. The valve body is available. New trim will be procured. To achieve improved feedwater pressure control to the SGS, the control valve will be relocated nearer the SGS rather than as it is now in the tower.

HRFS Spray Water Heat Exchanger - The SWHX has historically leaked at the tube-to-shell flange. The gasket was recently changed to an expanded TFE fluorocarbon type (Gortex) and leakage has been controlled. Spare gasket material is on-site.

HRFS Deaerator - The deaerator (400°F, 233 psi condenser) is heated by two electric immersion heaters for start-up. Spares are available on-site.

HRFS Safety Relief Valves - The Sandia pressure lab has assured a one-day turnaround for resetting relief pressures if the valves develop leak-through conditions and require relapping.

HRFS Steam Trap - The steam trap between the FWHX and deaerator is inappropriate for the required service. A new trap should be procured.

HRFS I&C - All level, flow, and pressure transducers should have on-site spare components.

HRFS Cooling Towers - Blower motors and belts are readily available locally. Loss of one decreases the total cooling capacity by less than four percent. Ethylene glycol content will be checked at the onset of cold weather.

#### 4. Solar Receiver System

RS Valves - All salt valves should have spare stem and bellows assemblies, and complete gasket sets on-site. Wind shields should be improved on all purge, drain, and flow control valves. Manufacturer's recommended spares for the operators and positioners should be on-site.

RS Heat Trace - Hot-to-cold junction failures will be repaired as possible. Dual spares will be ordered as soon as one of the two heaters on any area becomes unreparable. The spares will be installed only after the last original heater fails unreparably.

Wind Shields - Wind protection is required for all receiver valves and headers and some lines. This is essential to provide adequate receiver availability.

RS Piping - Excessive pipe vibration has been observed during certain emergency operations. These areas will be equipped with shock absorbers.

RS Solar Panel - Pre- and post-test visual inspections are used to detect incipient failures. No spare material or parts are recommended.

RS Cavity and Door - Spare cavity insulation is available on-site. Loss of the cavity door operability is considered not worthy of on-site spare parts. The door can be left open and the receiver operated normally.

RS I&C - All level, flow and pressure transducers should have on-site spare components. Solar flux gages are informational only and do not require on-site spares. Panel thermocouples used for receiver control must have on-site spares.

5. Turbogenerator

TG Controls and Relays - All safety controls and relays should have on-site spares. The generator exciter should have recommended spare components on-site.

TG Valves - The steam shutoff valve should have spare gaskets and trim on-site. The throttle valve and governor valves are unique. Problems with these will be resolved by local rebuilding or refurbishing as required.

TG Steam Traps - The steam traps are marginal for the application. Steam waste is excessive. These should be replaced with more conservatively specified traps.

TG Lub Oil System - The lube oil system should have on-site spare components for the electric lube oil pump and the components of the lube oil cooling loop. Water chemistry on the wet tower cooling loop should be continuously controlled and routinely monitored.

TG Condenser - The condenser air-ejector vacuum pump should have recommended spare parts on-site.

TG Relief Valve - The relief valve will be reworked and recalibrated at Sandia as required. No spare will be provided.

6. Master Control System

EMCON/DEC - No action is required. Standing maintenance contracts have prevented more than 48 hr system unavailability. Two additional operator displays should be added. The additional displays will provide more information to the operator without "paging" through the available information graphics.

Network 90 - The function of N-90 should be replaced by the EMCON process controller as soon as the N-90 warranty expires. Over 90 signals will be eliminated and thus control reliability for the SGS will be improved.



Acurex - The Acurex data loggers provide some MSEE data and the control of all salt-side heat trace. Manufacturer's recommended spare parts should be on-site. Maintenance training should be secured for a CRTF I&C technician.

HelioStat Controls - The MODCOMP system is under a standing, local maintenance contract. Downtime has been limited to less than 48 hours. The MODCOMP disk drives are obsolete and no longer are serviced by MODCOMP. The CRTF has spares and service has been obtained via a non-local source.

The Hewlett Packard computers provide the operator interface with the heliostats. Local maintenance is available on a four-hour response time. Downtime is normally less than 24 hours.

EPS - Spare components (relays, timers, etc.) should be in on-site inventories.

#### 7. Heliostats

The CRTF heliostats are maintained with an on-going effort. At least 95 percent of the 211 MSEE heliostats are available at all times.

ADDENDUM F  
MASTER CONTROL SUBSYSTEM DISPLAY

This addendum contains reproductions of the EMCON graphic displays and the predefined control groups in the 22-line format.

MSEE

8-F

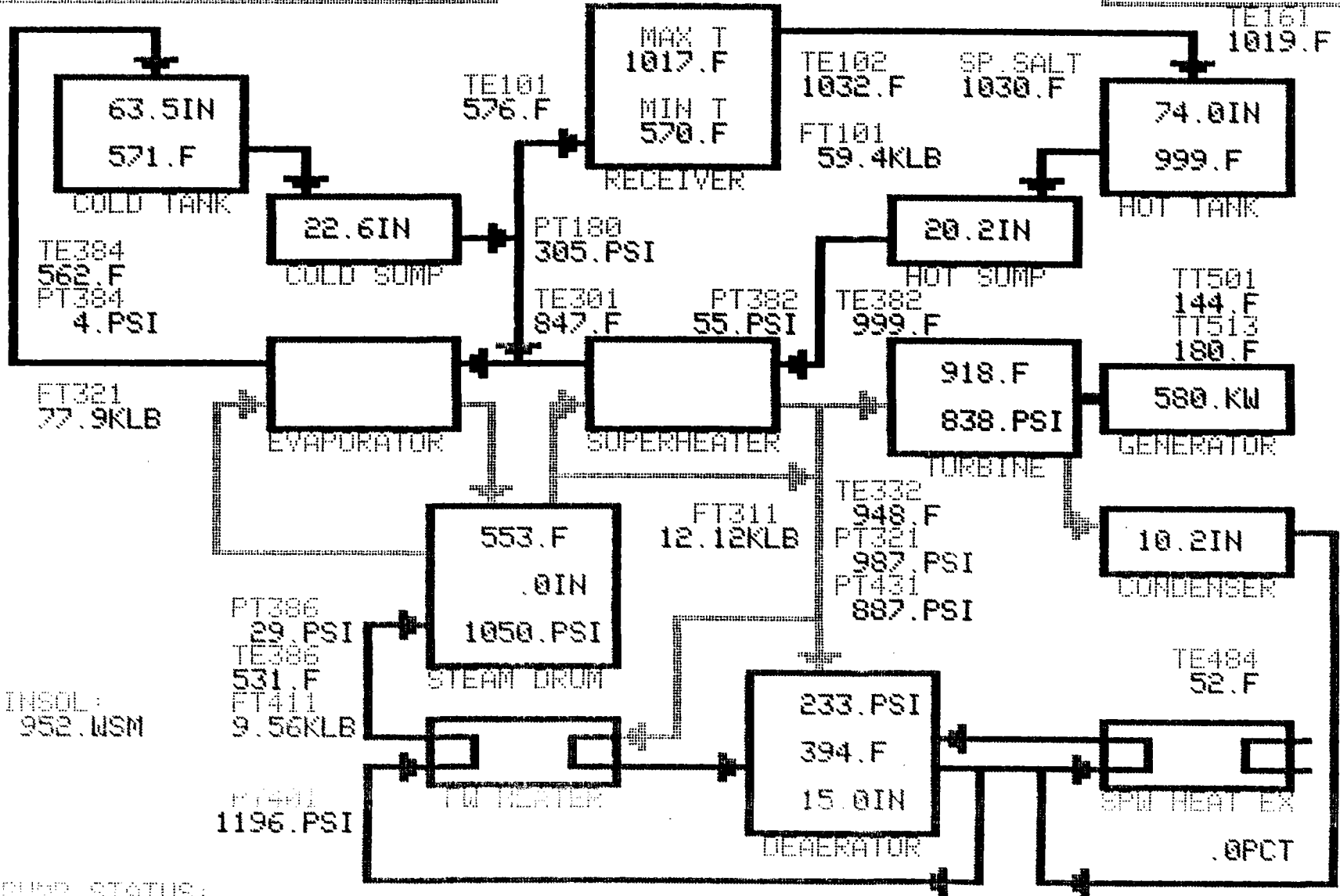

PUMP STATUS:

CSP BP HSP BOP FMP SMP CMP CNP CFP CTP CNP AEP EOP

■ ■ ■ ■ ■ ■ ■ ■ ■ ■ ■ ■ ■ ■ ■

RECEIVER

FCV100 THRU 198

SP. SALT  
1090.F

CAVITY  
DOOR  
OPEN

TE101  
625.F

CLOSED

LT161  
21.7IN

TE102 1019.F

LT151  
78.6IN

FCV101  
45.7PCT

HOT SURGE TANK

FCV180 THRU 189

PT182  
99.PSI

COLD  
SURGE  
TANK

CLOSED

PT181  
74.PSI

FT101  
81.3KLB  
FD101  
80.8KLB

TE161  
1003.F

FCV102  
45.6PCT

F4

TE291  
887.F

TE281  
624.F

FCV161  
34.1PCT

FCV162  
.0PCT

FCV199  
CLOSED



LT291  
60.9IN



LT281  
72.8IN

FCV151  
100.0PCT

BP  
ON

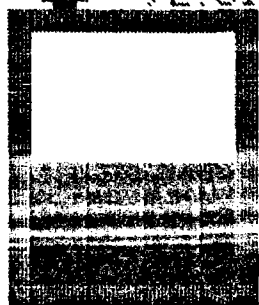

FCV281  
96.6PCT

LT201  
17.4IN

DSP  
ON

289.PSI



# THERMAL STORAGE

FS

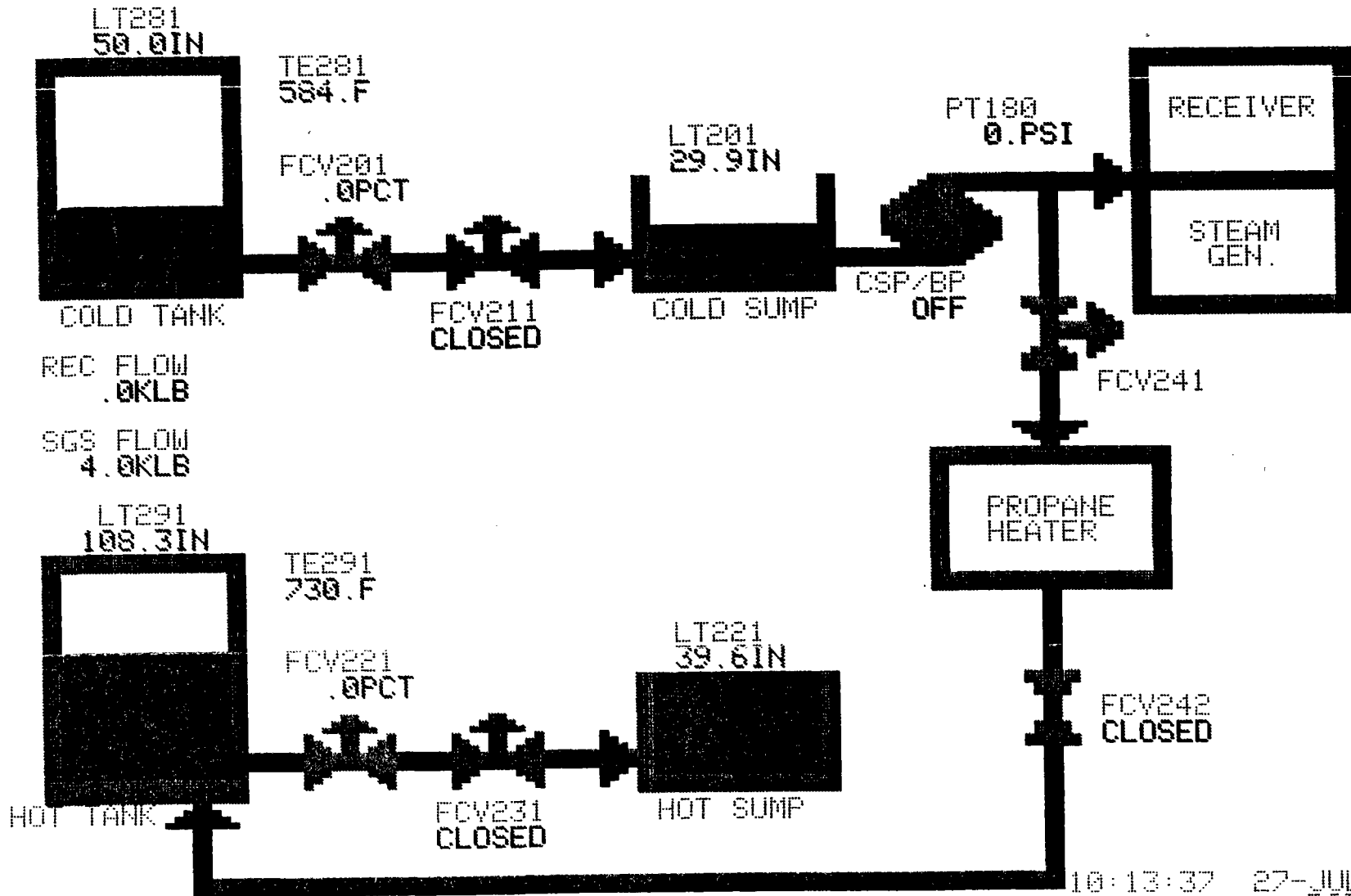

10:13:37 27-JUL-84  
DSP993

# STEAM GENERATOR

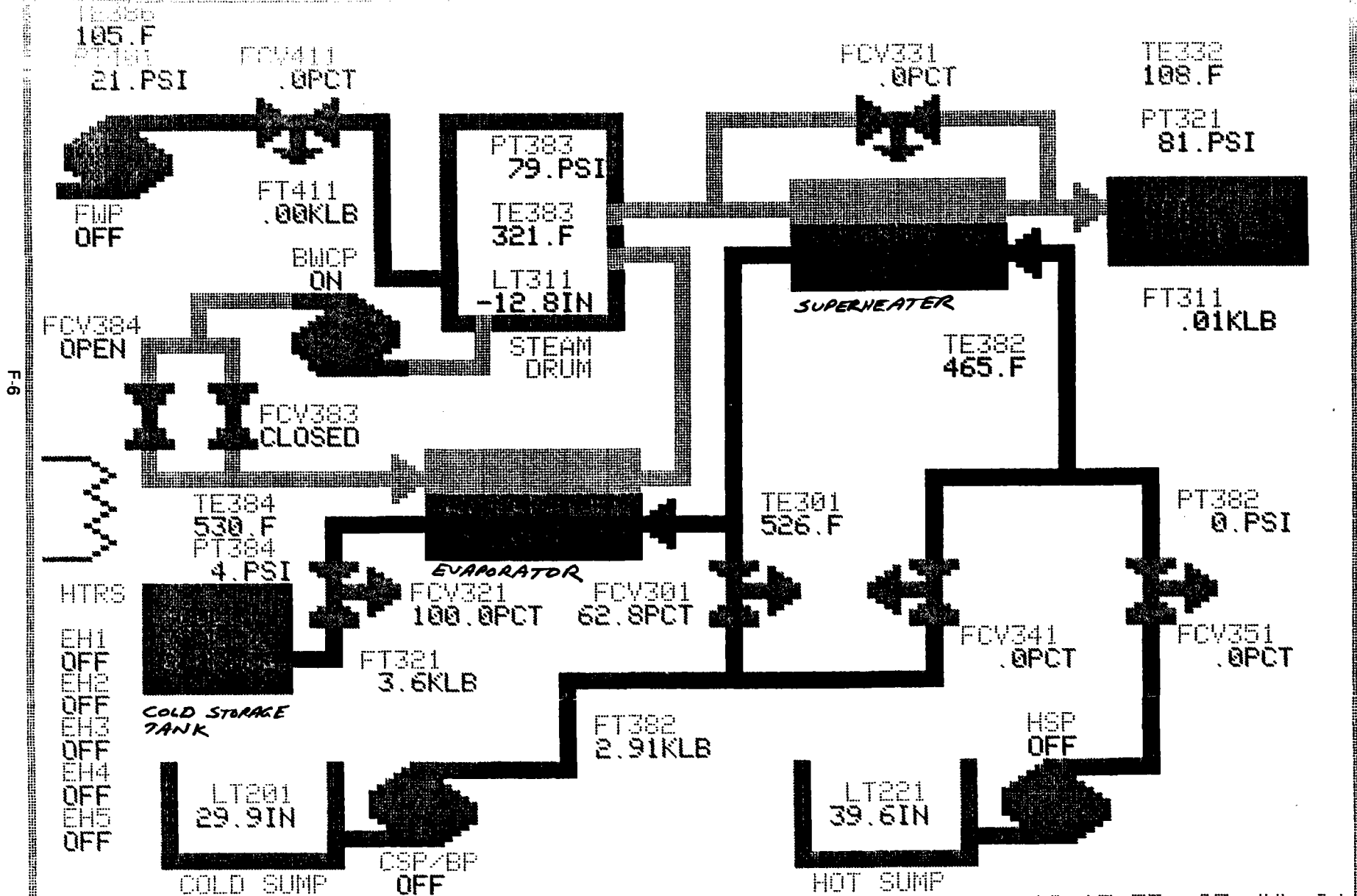

F 6

HEAT REJECTION

TRIP - PCM3

F-7

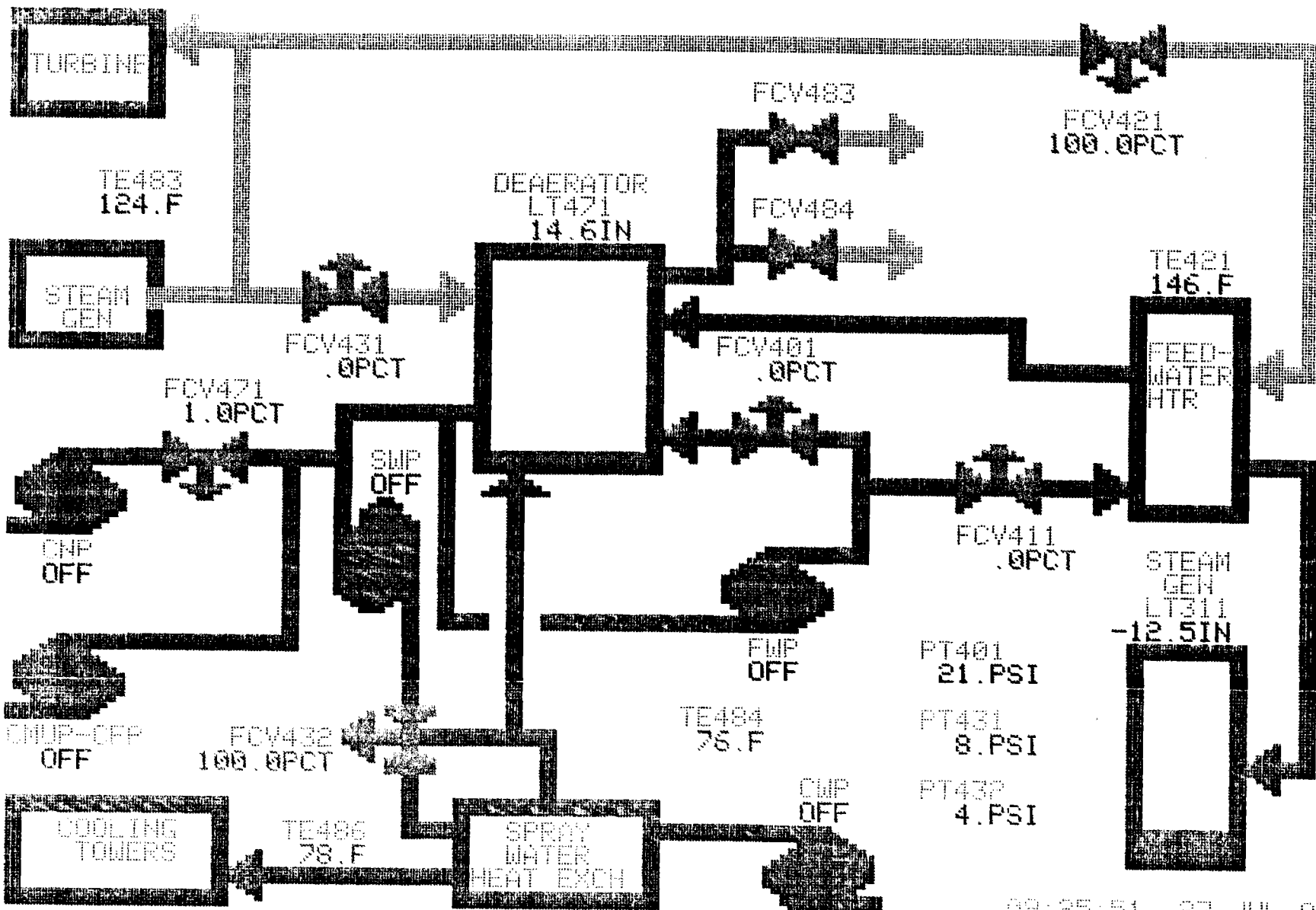

POWER GENERATION

OPERATING STATUS

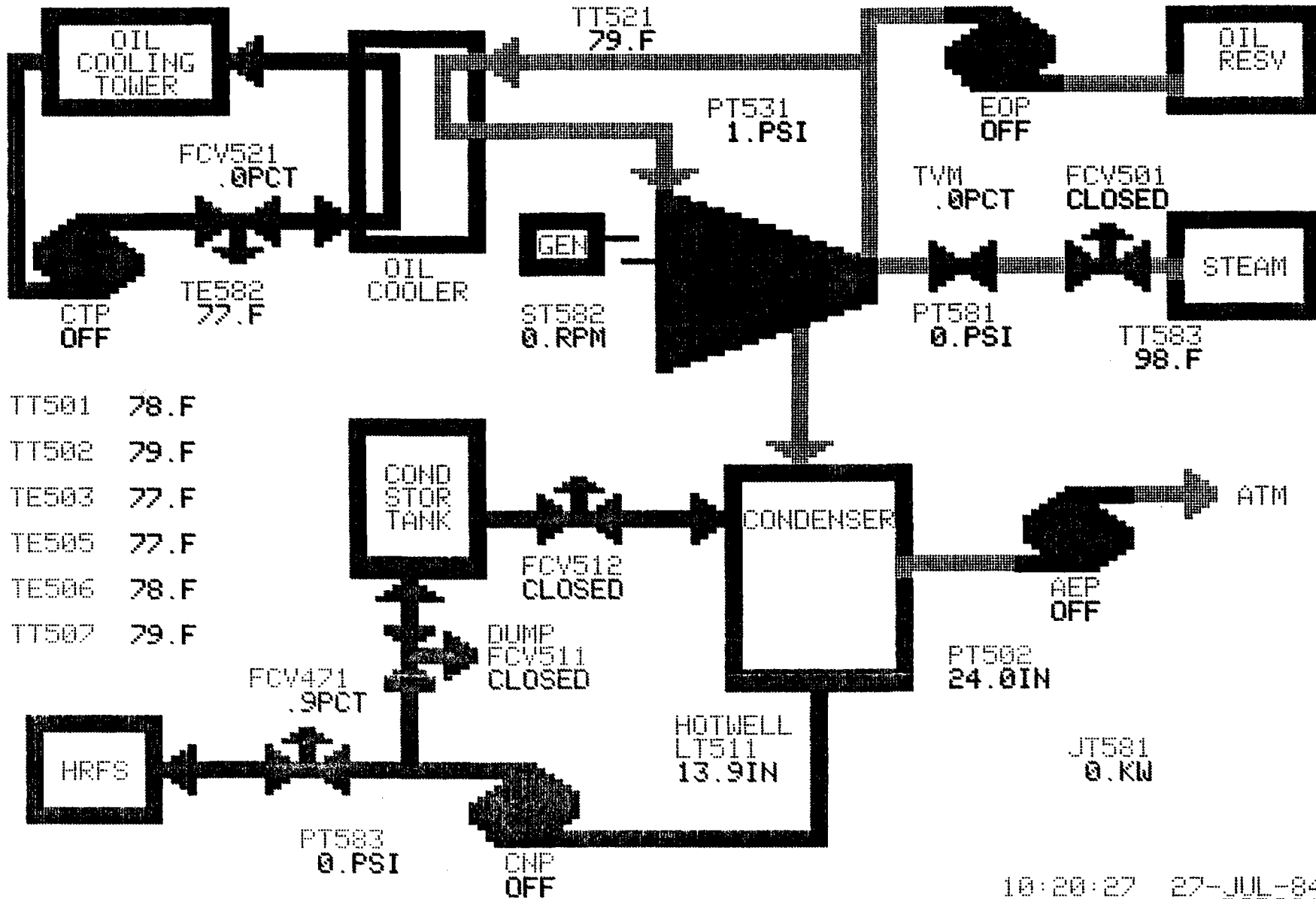

8-F



01	FCV101	95.0PCT	XXX	RCVR	SALT	FLOW	CONTROL	H	100.0	L	.0	PCM	1
02	FCV102	95.0PCT	XXX	RCVR	SALT	FLOW	CONTROL	H	100.0	L	.0	PCM	1
03	FT101	.0KLB	XXX	RCVR	SALT	FLOW		H	100.0	L	20.0	PCM	1
04	FD101	.0KLB	XXX	FLOW	DEMAND			H	100.0	L	.0	PCM	1
05	RCA	.0KLB	OFF	RCVR	CONTROL	ALGORM		H	100.0	L	.0	PCM	1
06	SP. SALT	750.F	XXX	RCVR	SALT	TEMP	SETPT	H	1060.	L	926.	PCM	1
07	PT180	0.PSI	XXX	RCVR	BOOST	PUMP	DSCHGE	H	400.	L	275.	PCM	3
08	PT181	0.PSI	XXX	RCVR	INLET	PRESS		H	125.	L	10.	PCM	1
09	SUN	0.WSM	XXX	EPPLEY	INSOL			H	4872.	L	0.	PCM	3
10	TE101	626.F	XXX	RCVR	INLET	HEADER		H	650.	L	500.	PCM	1
11	TE102	520.F	XXX	RCVR	OUTLET	HEADER		H	1060.	L	500.	PCM	1
12	FCV180T89	0.OFF		RCVR	DRAIN	VALVES						PCM	1
13	FCV190T98	0.OFF	OFF	RCVR	PURGE	VALVES						PCM	1
14	FCV190	0.OFF		PURGE	VALVE	PANELS	01.02					PCM	1
15	FCV191	0.OFF		PURGE	VALVE	PANELS	03.04					PCM	1
16	FCV192	0.OFF		PURGE	VALVE	PANELS	05.06					PCM	1
17	FCV193	0.OFF		PURGE	VALVE	PANELS	07.08					PCM	1
18	FCV194	0.OFF		PURGE	VALVE	PANELS	09.10					PCM	1
19	FCV195	0.OFF		PURGE	VALVE	PANELS	11.12					PCM	1
20	FCV196	0.OFF		PURGE	VALVE	PANELS	13.14					PCM	1
21	FCV197	0.OFF		PURGE	VALVE	PANELS	15.16					PCM	1
22	FCV198	0.OFF		PURGE	VALVE	PANELS	17.18					PCM	1

6-1

COPY

GROUP 01  
26-NOV-84 10:52:15

01	RES	MAN	0.OFF	RCVR	UNDER	MANUAL	CONTROL						
02	PT180		0.PSI	XXX	RCVR	BOOST	PUMP	DSCHGE	H	400.	L	275.	PCM 3
03	FCV101		95.2PCT	XXX	RCVR	SALT	FLOW	CONTRL	H	100.0	L	.0	PCM 1
04	FCV102		95.0PCT	XXX	RCVR	SALT	FLOW	CONTRL	H	100.0	L	.0	PCM 1
05	FCV151		.0PCT	XXX	RCVR	COLD	SURGE	TANK	H	100.0	L	.0	PCM 1
06	FCV161		.0IN	XXX	RCVR	DWNCMR	HOT	TANK	H	70.0	L	15.0	PCM 3
07	FCV162		.0IN	XXX	RCVR	DWNCMR	COLD	TANK	H	70.0	L	15.0	PCM 3
08	FCV201		33.7IN	XXX	TSS	COLD	SUMP	LEVEL	H	60.0	L	15.0	PCM 3
09	FCV199		0.OFF		RCVR	DRAIN	FILL	ISOLAT					PCM 3
10	ZSH199		1.ON	XXX	RCVR	DRAIN	FILL	ISOLAT					PCM 3
11	ZSL199		0.OFF	XXX	RCVR	DRAIN	FILL	ISOLAT					PCM 3
12	FCV211		0.OFF		TSS	COLD	SUMP	ISOLAT					PCM 3
13	ZSH211		0.OFF	XXX	TSS	COLD	SUMP	ISOLAT					PCM 3
14	ZSL211		1.ON	XXX	TSS	COLD	SUMP	ISOLAT					PCM 3
15	DR.OPN		0.OFF		RCVR	CAVITY	DOOR	OPEN					PCM 1
16	DR.CLS		0.OFF		RCVR	CAVITY	DOOR	CLOSE					PCM 1
17	ZSHDR		0.OFF	XXX	RCVR	CAVITY	DOOR	OPEN					PCM 1
18	ZSLDR		1.ON	XXX	RCVR	CAVITY	DOOR	CLOSED					PCM 1
19	PS281		1.ON	XXX	TSS	SGS	AIR	SUPPLY					PCM 3
20	RCK1		0.OFF	XXX	RS	CHECK							PCM 1
21	RCK3		0.OFF	XXX	RS	CHECK							PCM 3

F-10

COPY

GROUP 02  
26-NOV-84 10:53:43

WT	UNIT	UNIT	RCVR	COLD	SURGE	TANK	H	50.0	L	10.0	PCM	1
01	LT161	.0IN	XXX RCVR	HOT	SURGE	TANK	H	70.0	L	15.0	PCM	3
02	LT201	33.7IN	XXX TSS	COLD	SUMP	LEVEL	H	60.0	L	15.0	PCM	3
03	LT221	35.0IN	XXX TSS	HOT	SUMP	LEVEL	H	41.0	L	15.0	PCM	3
04	LT281	119.0IN	XXX TSS	COLD	TANK	LEVEL	H	134.0	L	15.0	PCM	3
05	LT291	.1IN	XXX TSS	HOT	TANK	LEVEL	H	190.0	L	10.0	PCM	3
06	PT180	0.PSI	XXX RCVR	BOOST	PUMP	DSCHGE	H	400.	L	275.	PCM	3
07	PT181	0.PSI	XXX RCVR	INLET	PRESS		H	125.	L	10.	PCM	1
08	PT182	1.PSI	XXX RCVR	COLD	SURGE	TANK	H	180.	L	10.	PCM	1
09	FT101	.0KLB	XXX RCVR	SALT	FLOW		H	100.0	L	20.0	PCM	1
10	TE101	622.F	XXX RCVR	INLET	HEADER		H	650.	L	500.	PCM	1
11	TE102	519.F	XXX RCVR	OUTLET	HEADER		H	1060.	L	500.	PCM	1
12	TE181	276.F	XXX BOOST	PUMP	SUMP	VENT	H	350.	L	-99.	PCM	3
13	TE182	582.F	XXX RCVR	COLD	SURGE	TANK	H	750.	L	500.	PCM	1
14	TE183	495.F	XXX RCVR	HOT	SURGE	TANK	H	1070.	L	500.	PCM	1
15	TE184	258.F	XXX RCVR	HOT	SURGE	VENT	H	400.	L	-99.	PCM	1
16	TE211	84.F	XXX TSS	COLD	SUMP	VENT	H	400.	L	-99.	PCM	3
17	TE231	63.F	XXX TSS	HOT	SUMP	VENT	H	400.	L	-99.	PCM	3
18	TE231	542.F	XXX TSS	CTANK	RAKE	LOWER	H	750.	L	500.	PCM	3
19	TE283	530.F	XXX TSS	CTANK	RAKE	UPPER	H	750.	L	500.	PCM	3
20	TE291	148.F	XXX TSS	HTANK	RAKE	LOWER	H	1070.	L	500.	PCM	3
21	TE293	149.F	XXX TSS	HTANK	RAKE	UPPER	H	1070.	L	500.	PCM	3

COPY

01	FCV201	0. OFF	XXX	TSS	COLD	SUMP	LEVEL	H	60.0	L	15.0	PCM
02	FCV211	0. OFF		TSS	COLD	SUMP	ISOLAT					PCM
03	ZSH211	0. OFF	XXX	TSS	COLD	SUMP	ISOLAT					PCM
04	ZSL211	1. ON	XXX	TSS	COLD	SUMP	ISOLAT					PCM
05	FCV221	35. BIN	XXX	TSS	HOT	SUMP	LEVEL	H	100.0	L	.0	PCM
06	FCV231	0. OFF		TSS	HOT	SUMP	ISOLAT					PCM
07	ZSH231	0. OFF	XXX	TSS	HOT	SUMP	ISOLAT					PCM
08	ZSL231	1. ON	XXX	TSS	HOT	SUMP	ISOLAT					PCM
09	PT180	0. PSI	XXX	RCVR	BOOST	PUMP	DSCHGE	H	400.	L	275.	PCM
10	CSP	0. OFF		TSS	COLD	SALT	PUMP					PCM
11	CSP. EN	0. OFF		TSS	CSP	ENABLE						PCM
12	ZSHCSP	0. OFF	XXX	TSS	COLD	SALT	PUMP					PCM
13	BP	0. OFF		RCVR	BOOST	PUMP						PCM
14	BP. EN	0. OFF		RCVR	BP	ENABLE						PCM
15	ZSHBP	0. OFF	XXX	RCVR	SALT	BOOST	PUMP					PCM
16	HSP	0. OFF		TSS	HOT	SALT	PUMP					PCM
17	HSP. EN	0. OFF		TSS	HSP	ENABLE						PCM
18	ZSHHSP	0. OFF	XXX	TSS	HOT	SALT	PUMP					PCM
19	TE180	60. F	XXX	BOOST	PUMP	BEARNG	TEMP	H	190.	L	-99.	PCM
20	TE286	113. F	XXX	TSS	COLD	PUMP	BEARNG	H	190.	L	-99.	PCM
21	TE307	61. F	XXX	HOT	SALT	PUMP	BEARNG	H	190.	L	-99.	PCM
22	TCK	0. OFF	XXX	TSS	CHECK							PCM

F-12

COPY

GROUP 04  
26-NOV-84 10:56:52

	FCV	ZSH	ZSL	PT	LT	TE	UNIT	TYPE	LEVEL	UNIT	UNIT	UNIT	UNIT	UNIT	UNIT	UNIT
01	FCV241						TSS	FRPANE	HEATER	ISOLAT						PCM
02	FCV242	0.OFF					TSS	FRPANE	HEATER	ISOLAT						PCM
03	ZSH242	0.OFF	XXX				TSS	FRPANE	HEATER	ISOLAT						PCM
04	ZSL242	1.ON	XXX				TSS	FRPANE	HEATER	ISOLAT						PCM
05	FCV201	33.7IN	XXX				TSS	COLD	SUMP	LEVEL	H	60.0	L	15.0		PCM
06	FCV221	34.9IN	XXX				TSS	HOT	SUMP	LEVEL	H	100.0	L	.0		PCM
07	PT180	0.PSI	XXX				RCVR	BOOST	PUMP	DSCHGE	H	400.	L	275.		PCM
08	FCV211	0.OFF					TSS	COLD	SUMP	ISOLAT						PCM
09	ZSH211	0.OFF	XXX				TSS	COLD	SUMP	ISOLAT						PCM
10	ZSL211	1.ON	XXX				TSS	COLD	SUMP	ISOLAT						PCM
11	LT201	33.7IN	XXX				TSS	COLD	SUMP	LEVEL	H	60.0	L	15.0		PCM
12	LT221	35.0IN	XXX				TSS	HOT	SUMP	LEVEL	H	41.0	L	15.0		PCM
13	LT281	119.4IN	XXX				TSS	COLD	TANK	LEVEL	H	134.0	L	15.0		PCM
14	TE281	542.F	XXX				TSS	CTANK	RAKE	LOWER	H	750.	L	500.		PCM
15	TE282	541.F	XXX				TSS	CTANK	RAKE	MIDDLE	H	750.	L	500.		PCM
16	TE283	530.F	XXX				TSS	CTANK	RAKE	UPPER	H	750.	L	500.		PCM
17	LT291	.1IN	XXX				TSS	HOT	TANK	LEVEL	H	190.0	L	10.0		PCM
18	TE291	148.F	XXX				TSS	HTANK	RAKE	LOWER	H	1070.	L	500.		PCM
19	TE292	149.F	XXX				TSS	HTANK	RAKE	MIDDLE	H	1070.	L	500.		PCM
20	TE293	149.F	XXX				TSS	HTANK	RAKE	UPPER	H	1070.	L	500.		PCM

COPY

GROUP 05  
26-NOV-84 10:58:37

01	TE131	51.F	XXX	RCVR	PANEL	BACK	UPPER	H	645.	L	500.	PCM	1
02	TE132	41.F	XXX	RCVR	PANEL	BACK	UPPER	H	745.	L	500.	PCM	1
03	TE133	44.F	XXX	RCVR	PANEL	BACK	UPPER	H	815.	L	500.	PCM	1
04	TE134	43.F	XXX	RCVR	PANEL	BACK	UPPER	H	915.	L	500.	PCM	1
05	TE135	41.F	XXX	RCVR	PANEL	BACK	UPPER	H	980.	L	500.	PCM	1
06	TE136	48.F	XXX	RCVR	PANEL	BACK	UPPER	H	1045.	L	500.	PCM	1
07	TE137	38.F	XXX	RCVR	PANEL	BACK	MIDDLE	H	680.	L	500.	PCM	1
08	TE138	38.F	XXX	RCVR	PANEL	BACK	MIDDLE	H	735.	L	500.	PCM	1
09	TE139	40.F	XXX	RCVR	PANEL	BACK	MIDDLE	H	825.	L	500.	PCM	1
10	TE140	63.F	XXX	RCVR	PANEL	BACK	MIDDLE	H	905.	L	500.	PCM	1
11	TE141	41.F	XXX	RCVR	PANEL	BACK	MIDDLE	H	990.	L	500.	PCM	1
12	TE142	38.F	XXX	RCVR	PANEL	BACK	MIDDLE	H	1045.	L	500.	PCM	1
13	TE143	47.F	XXX	RCVR	PANEL	BACK	LOWER	H	660.	L	500.	PCM	1
14	TE144	40.F	XXX	RCVR	PANEL	BACK	LOWER	H	725.	L	500.	PCM	1
15	TE145	41.F	XXX	RCVR	PANEL	BACK	LOWER	H	830.	L	500.	PCM	1
16	TE146	38.F	XXX	RCVR	PANEL	BACK	LOWER	H	895.	L	500.	PCM	1
17	TE147	40.F	XXX	RCVR	PANEL	BACK	LOWER	H	985.	L	500.	PCM	1
18	TE148	41.F	XXX	RCVR	PANEL	BACK	LOWER	H	1035.	L	500.	PCM	1
19	RMAXT	63.F	XXX	RCVR	PANEL	MAX	TEMP	H	1080.	L	500.	PCM	1
20	RMINT	37.F	XXX	RCVR	PANEL	MIN	TEMP	H	1080.	L	500.	PCM	1

F14

COPY

GROUP 06  
26-NOV-84 12:29:34

	TE	VAL	UNIT	RCVR	COND	SURGE	TANK	H	50	L	500	PCM	1	
01	TE182	580	F	XXX	RCVR	HOT	SURGE	TANK	H	1070	L	500	PCM	1
02	TE183	531	F	XXX	RCVR	HOT	SURGE	TANK	H	1070	L	500	PCM	1
03	TE185	281	F	XXX	RCVR	PASS02	OUTLET	TEMP	H	665	L	500	PCM	1
04	TE186	332	F	XXX	RCVR	PASS03	OUTLET	TEMP	H	690	L	500	PCM	1
05	TE187	246	F	XXX	RCVR	PASS04	OUTLET	TEMP	H	720	L	500	PCM	1
06	TE188	103	F	XXX	RCVR	PASS05	OUTLET	TEMP	H	750	L	500	PCM	1
07	TE189	290	F	XXX	RCVR	PASS06	OUTLET	TEMP	H	780	L	500	PCM	1
08	TE190	353	F	XXX	RCVR	PASS07	OUTLET	TEMP	H	810	L	500	PCM	1
09	TE191	298	F	XXX	RCVR	PASS08	OUTLET	TEMP	H	835	L	500	PCM	1
10	TE192	373	F	XXX	RCVR	PASS09	OUTLET	TEMP	H	865	L	500	PCM	1
11	TE193	276	F	XXX	RCVR	PASS12	OUTLET	TEMP	H	950	L	500	PCM	1
12	TE194	386	F	XXX	RCVR	PASS13	OUTLET	TEMP	H	975	L	500	PCM	1
13	TE195	317	F	XXX	RCVR	PASS14	OUTLET	TEMP	H	990	L	500	PCM	1
14	TE196	312	F	XXX	RCVR	PASS15	OUTLET	TEMP	H	1010	L	500	PCM	1
15	TE197	270	F	XXX	RCVR	PASS16	OUTLET	TEMP	H	1030	L	500	PCM	1
16	TE198	295	F	XXX	RCVR	PASS17	OUTLET	TEMP	H	1050	L	500	PCM	1

F-15

COPY

GROUP 07  
 20110101 15:48:06

01  
02  
03  
04  
05  
06  
07  
08  
09  
10  
11  
12  
13  
14  
15  
16  
17  
18  
19  
20  
F-16

Line	Code	Status	RCVR	DRAIN	NO.	State	PCM	Value
01	ZSH180	0.OFF	XXX	RCVR	DRAIN	NO. 1	OPEN	PCM 1
02	ZSH181	0.OFF	XXX	RCVR	DRAIN	NO. 2	OPEN	PCM 1
03	ZSH182	0.OFF	XXX	RCVR	DRAIN	NO. 3	OPEN	PCM 1
04	ZSH183	0.OFF	XXX	RCVR	DRAIN	NO. 4	OPEN	PCM 1
05	ZSH184	0.OFF	XXX	RCVR	DRAIN	NO. 5	OPEN	PCM 1
06	ZSH185	0.OFF	XXX	RCVR	DRAIN	NO. 6	OPEN	PCM 1
07	ZSH186	0.OFF	XXX	RCVR	DRAIN	NO. 7	OPEN	PCM 1
08	ZSH187	0.OFF	XXX	RCVR	DRAIN	NO. 8	OPEN	PCM 1
09	ZSH188	0.OFF	XXX	RCVR	DRAIN	NO. 9	OPEN	PCM 1
10	ZSH189	0.OFF	XXX	RCVR	DRAIN	NO. 10	OPEN	PCM 1
11	ZSL180	1.ON	XXX	RCVR	DRAIN	NO. 1	CLOSED	PCM 1
12	ZSL181	1.ON	XXX	RCVR	DRAIN	NO. 2	CLOSED	PCM 1
13	ZSL182	1.ON	XXX	RCVR	DRAIN	NO. 3	CLOSED	PCM 1
14	ZSL183	1.ON	XXX	RCVR	DRAIN	NO. 4	CLOSED	PCM 1
15	ZSL184	1.ON	XXX	RCVR	DRAIN	NO. 5	CLOSED	PCM 1
16	ZSL185	1.ON	XXX	RCVR	DRAIN	NO. 6	CLOSED	PCM 1
17	ZSL186	1.ON	XXX	RCVR	DRAIN	NO. 7	CLOSED	PCM 1
18	ZSL187	1.ON	XXX	RCVR	DRAIN	NO. 8	CLOSED	PCM 1
19	ZSL188	1.ON	XXX	RCVR	DRAIN	NO. 9	CLOSED	PCM 1
20	ZSL189	1.ON	XXX	RCVR	DRAIN	NO. 10	CLOSED	PCM 1

COPY

GROUP 08



01	ZSH190	0. OFF	XXX	RCVR	PURGE	NO. 2	OPEN	PCM	1
02	ZSH191	0. OFF	XXX	RCVR	PURGE	NO. 3	OPEN	PCM	1
03	ZSH192	0. OFF	XXX	RCVR	PURGE	NO. 4	OPEN	PCM	1
04	ZSH193	0. OFF	XXX	RCVR	PURGE	NO. 5	OPEN	PCM	1
05	ZSH194	0. OFF	XXX	RCVR	PURGE	NO. 6	OPEN	PCM	1
06	ZSH195	0. OFF	XXX	RCVR	PURGE	NO. 7	OPEN	PCM	1
07	ZSH196	0. OFF	XXX	RCVR	PURGE	NO. 8	OPEN	PCM	1
08	ZSH197	0. OFF	XXX	RCVR	PURGE	NO. 9	OPEN	PCM	1
09	ZSH198	0. OFF	XXX	RCVR	PURGE	NO. 1	OPEN	PCM	1
10	ZSL190	1. ON	XXX	RCVR	PURGE	NO. 1	CLOSED	PCM	1
11	ZSL191	1. ON	XXX	RCVR	PURGE	NO. 2	CLOSED	PCM	1
12	ZSL192	1. ON	XXX	RCVR	PURGE	NO. 3	CLOSED	PCM	1
13	ZSL193	1. ON	XXX	RCVR	PURGE	NO. 4	CLOSED	PCM	1
14	ZSL194	1. ON	XXX	RCVR	PURGE	NO. 5	CLOSED	PCM	1
15	ZSL195	1. ON	XXX	RCVR	PURGE	NO. 6	CLOSED	PCM	1
16	ZSL196	1. ON	XXX	RCVR	PURGE	NO. 7	CLOSED	PCM	1
17	ZSL197	1. ON	XXX	RCVR	PURGE	NO. 8	CLOSED	PCM	1
18	ZSL198	1. ON	XXX	RCVR	PURGE	NO. 9	CLOSED	PCM	1

F17

COPY

GROUP 09  
26-NOV-84 16:49:24

01	TE101	621.F	XXX	RCVR	INLET	HEADER	H	650.	L	500.	PCM	1
02	TE103	50.F	XXX	RCVR	PASS01	OUTLET	TEMP	640.	L	500.	PCM	1
03	TE104	46.F	XXX	RCVR	PASS02	OUTLET	TEMP	665.	L	500.	PCM	1
04	TE105	50.F	XXX	RCVR	PASS03	OUTLET	TEMP	690.	L	500.	PCM	1
05	TE106	44.F	XXX	RCVR	PASS04	OUTLET	TEMP	720.	L	500.	PCM	1
06	TE107	58.F	XXX	RCVR	PASS05	OUTLET	TEMP	750.	L	500.	PCM	1
07	TE108	44.F	XXX	RCVR	PASS06	OUTLET	TEMP	780.	L	500.	PCM	1
08	TE109	61.F	XXX	RCVR	PASS07	OUTLET	TEMP	810.	L	500.	PCM	1
09	TE110	47.F	XXX	RCVR	PASS08	OUTLET	TEMP	835.	L	500.	PCM	1
10	TE111	56.F	XXX	RCVR	PASS09	OUTLET	TEMP	865.	L	500.	PCM	1
11	TE112	44.F	XXX	RCVR	PASS10	OUTLET	TEMP	890.	L	500.	PCM	1
12	TE113	54.F	XXX	RCVR	PASS11	OUTLET	TEMP	920.	L	500.	PCM	1
13	TE114	47.F	XXX	RCVR	PASS12	OUTLET	TEMP	950.	L	500.	PCM	1
14	TE115	53.F	XXX	RCVR	PASS13	OUTLET	TEMP	975.	L	500.	PCM	1
15	TE116	46.F	XXX	RCVR	PASS14	OUTLET	TEMP	990.	L	500.	PCM	1
16	TE117	52.F	XXX	RCVR	PASS15	OUTLET	TEMP	1010.	L	500.	PCM	1
17	TE118	41.F	XXX	RCVR	PASS16	OUTLET	TEMP	1030.	L	500.	PCM	1
18	TE119	50.F	XXX	RCVR	PASS17	OUTLET	TEMP	1050.	L	500.	PCM	1
19	TE120	40.F	XXX	RCVR	PASS18	OUTLET	TEMP	1070.	L	500.	PCM	1
20	TE102	504.F	XXX	RCVR	OUTLET	HEADER	H	1060.	L	500.	PCM	1

818

COPY

GROUP 10  
26-NOV-84 16:50:48

01	FCV100	94.9PCT	XXX	RCVR	SALT	FLOW	CONTRL	H	100.0	L	.0	PCM	1
02	FCV102	94.9PCT	XXX	RCVR	SALT	FLOW	CONTRL	H	100.0	L	.0	PCM	1
03	FCV151	100.0PCT	XXX	RCVR	COLD	SURGE	TANK	H	100.0	L	.0	PCM	1
04	FCV161	.0IN	XXX	RCVR	DWNCMR	HOT	TANK	H	70.0	L	15.0	PCM	3
05	FCV162	.0IN	XXX	RCVR	DWNCMR	COLD	TANK	H	70.0	L	15.0	PCM	3
06	FCV201	33.9IN	XXX	TSS	COLD	SUMP	LEVEL	H	60.0	L	15.0	PCM	3
07	RCA	.0KLB	OFF	RCVR	CONTRL	ALGORM		H	100.0	L	.0	PCM	1
08	FCV199	0.0OFF		RCVR	DRAIN	FILL	ISOLAT					PCM	3
09	ZSH199	1.0ON	XXX	RCVR	DRAIN	FILL	ISOLAT					PCM	3
10	ZSL199	0.0OFF	XXX	RCVR	DRAIN	FILL	ISOLAT					PCM	3
11	FCV211	0.0OFF		TSS	COLD	SUMP	ISOLAT					PCM	3
12	ZSH211	0.0OFF	XXX	TSS	COLD	SUMP	ISOLAT					PCM	3
13	ZSL211	1.0ON	XXX	TSS	COLD	SUMP	ISOLAT					PCM	3
14	FCV180T89	0.0OFF		RCVR	DRAIN	VALVES						PCM	1
15	FCV190T98	0.0OFF	005	RCVR	PURGE	VALVES						PCM	1
16	CSP	0.0OFF		TSS	COLD	SALT	PUMP					PCM	3
17	ZSHCSP	0.0OFF	XXX	TSS	COLD	SALT	PUMP					PCM	3
18	BP	0.0OFF		RCVR	BOOST	PUMP						PCM	3
19	ZSHBP	0.0OFF	XXX	RCVR	SALT	BOOST	PUMP					PCM	3
20	RF	0.0OFF	005	RCVR	FILL							PCM	3
21	RS	0.0OFF	005	RCVR	DRAIN							PCM	3
22	RS.MAN	0.0OFF	XXX	RCVR	UNDER	MANUAL	CONTRL					PCM	3

F-19

COPY

02	SP. 321	99.5 PCT	XXX	SGS	FCV321	MANUAL	SETPT	H	100.0	L	.0	PCM	3
03	SP. 341	.0 PCT	XXX	SGS	FCV341	MANUAL	SETPT	H	100.0	L	.0	PCM	3
04	SP. 351	6.8 PCT	XXX	SGS	FCV351	MANUAL	SETPT	H	100.0	L	.0	PCM	3
05	FCV201	33.9 IN	XXX	TSS	COLD	SUMP	LEVEL	H	60.0	L	15.0	PCM	3
06	FCV221	34.8 IN	XXX	TSS	HOT	SUMP	LEVEL	H	100.0	L	.0	PCM	3
07	FCV431	.0 PCT	XXX	HRS	STEAM	CONTRL		H	100.0	L	.0	PCM	2
08	FCV491	.0 PSI	XXX	SGS	STEAM	DLIVRY	PRESS	H	1150.	L	950.	PCM	2
09	MAN. 321	.0 OFF		REQEST	MANUAL	CONTRL	FCV321					PCM	3
10	FCV231	.0 OFF		TSS	COLD	SUMP	ISOLAT					PCM	3
11	FCV231	.0 OFF		TSS	HOT	SUMP	ISOLAT					PCM	3
12	SRU	.0 OFF	COS	SGS	SERVCE	COLD	FLOW					PCM	3
13	SRU	.0 OFF	COS	SGS	SERVCE	STDBY	ONLINE					PCM	3
14	SDC	.0 OFF		SGS	SALT	DRAIN	COMMND					PCM	3
15	MAN. SDC	.0 OFF		SGS	SALT	DRAIN	COMMND					PCM	3
16	SRD	.0 OFF	COS	SGS	SERVCE	ONLINE	STDBY					PCM	3
17	SS	.0 OFF	COS	SGS	DIURNL	SHUTDN						PCM	3
18	HSP	.0 OFF		TSS	HOT	SALT	PUMP					PCM	3
19	CSP	.0 OFF		TSS	COLD	SALT	PUMP					PCM	3
20	BT180	.0 PSI	XXX	RCVR	BOOST	PUMP	DSCHGE	H	400.	L	275.	PCM	3
21	BT431	6. PSI	XXX	HRS	HIGH	PRESS	STEAM	H	1200.	L	900.	PCM	2
22	BT432	1. PSI	XXX	HRS	BEVTR	PRESS	CONTRL	H	250.	L	200.	PCM	2

GROUP 12

F-20

COPY

LINE	UNIT	VAL	UNIT	TYPE	UNIT	UNIT	UNIT	UNIT	UNIT	UNIT	UNIT	UNIT
01	SP. DL	0 IN	XXX	SGS	DRUM	LEVEL	SETPT	H	4.0	L	-4.0	PCM 3
02	SP. SP	1100. PSI	XXX	SGS	STEAM	PRESS	SETPT	H	1130.	L	1070.	PCM 3
03	SP. ST	950. F	XXX	SGS	STEAM	TEMP	SETPT	H	980.	L	920.	PCM 3
04	MAN. 301	0.0PCT	XXX	SGS	FCV301	MANUAL	SETPT	H	100.0	L	.0	PCM 3
05	MAN. 301	0.0OFF	REEST	MANUAL	CONTROL	FCV321						PCM 3
06	SP. 321	99.5PCT	XXX	SGS	FCV321	MANUAL	SETPT	H	100.0	L	.0	PCM 3
07	MAN. 331	0.0OFF	REEST	MANUAL	CONTRL	FCV331						PCM 3
08	SP. 331	10.0PCT	XXX	SGS	FCV331	MANUAL	SETPT	H	100.0	L	.0	PCM 3
09	MAN. 341	0.0OFF	REEST	MANUAL	CONTROL	FCV341						PCM 3
10	SP. 341	0.0PCT	XXX	SGS	FCV341	MANUAL	SETPT	H	100.0	L	.0	PCM 3
11	MAN. 351	0.0OFF	REEST	MANUAL	CONTROL	FCV351						PCM 3
12	SP. 351	6.8PCT	XXX	SGS	FCV351	MANUAL	SETPT	H	100.0	L	.0	PCM 3
13	MAN. 411	0.0OFF	REEST	MANUAL	CONTROL	FCV411						PCM 3
14	SP. 411	0.0PCT	XXX	SGS	FCV411	MANUAL	SETPT	H	100.0	L	.0	PCM 3
15	MAN. 38182	0.0OFF	SGS	EVAP	SUPHTR	DRAIN						PCM 3
16	FCV38182	0.0OFF	SGS	EVAP	SUPHTR	DRAIN						PCM 3
17	MAN. 383	0.0OFF	SGS	ELECT	HEATER	BYPASS						PCM 3
18	FCV383	0.0OFF	SGS	ELECT	HEATER	BYPASS						PCM 3
19	MAN. 384	0.0OFF	SGS	ELECT	HEATER	STRUP						PCM 3
20	FCV384	0.0OFF	SGS	ELECT	HEATER	STRUP						PCM 3

F-21

COPY

01	SP	850	F	XXX	SGS	EVAP	SAL	TEMP	SETPT	H	870	L	700	PCM	3
02	SP	.0IN		XXX	SGS	DRUM	LEVEL	SETPT	H		4.0	L	-4.0	PCM	3
03	SP	1100	PSI	XXX	SGS	STEAM	PRESS	SETPT	H		1130	L	1070	PCM	3
04	SP	950	F	XXX	SGS	STEAM	TEMP	SETPT	H		980	L	920	PCM	3
05	MAN	0	OFF		REQUEST	MANUAL	CONTRL	FCV301						PCM	3
06	SP	0	PCT	XXX	SGS	FCV301	MANUAL	SETPT	H		100.0	L	.0	PCM	3
07	MAN	0	OFF		REQUEST	MANUAL	CONTRL	FCV321						PCM	3
08	SP	99	SPCT	XXX	SGS	FCV321	MANUAL	SETPT	H		100.0	L	.0	PCM	3
09	MAN	0	OFF		REQUEST	MANUAL	CONTRL	FCV331						PCM	3
10	SP	10	PCT	XXX	SGS	FCV331	MANUAL	SETPT	H		100.0	L	.0	PCM	3
11	MAN	0	OFF		REQUEST	MANUAL	CONTRL	FCV341						PCM	3
12	SP	0	PCT	XXX	SGS	FCV341	MANUAL	SETPT	H		100.0	L	.0	PCM	3
13	MAN	0	OFF		REQUEST	MANUAL	CONTRL	FCV351						PCM	3
14	SP	6	SPCT	XXX	SGS	FCV351	MANUAL	SETPT	H		100.0	L	.0	PCM	3
15	MAN	0	OFF		REQUEST	MANUAL	CONTRL	FCV411						PCM	3
16	SP	0	PCT	XXX	SGS	FCV411	MANUAL	SETPT	H		100.0	L	.0	PCM	3
17	MAN	0	OFF		SGS	EVAP	SUPHTR	DRAIN						PCM	3
18	FCV	0	OFF		SGS	EVAP	SUPHTR	DRAIN						PCM	3
19	MAN	0	OFF		SGS	ELECT	HEATER	BYPASS						PCM	3
20	FCV	0	OFF		SGS	ELECT	HEATER	BYPASS						PCM	3
21	MAN	0	OFF		SGS	ELECT	HEATER	STRTP						PCM	3
22	FCV	0	OFF		SGS	ELECT	HEATER	STRTP						PCM	3

F-22

COPY

	24	31N	XXX	SGS	STEAM	DRUM	WATER	H	4.0	L	-4.0	PCM	3
01	TE483	73.F	XXX	HRFS	HIGH	PRESS	STEAM	H	990.	L	850.	PCM	2
02	PT383	10.PSI	XXX	SGS	STEAM	DRUM	PRESS	H	1250.	L	950.	PCM	3
03	FT411	.01KLB	XXX	HRFS	FEED	WATER	FLOW	H	16.00	L	.00	PCM	3
04	FT311	.01KLB	XXX	SGS	MAIN	STEAM	FLOW	H	12.60	L	3.20	PCM	3
05	FT381	988.LB	XXX	SGS	ATTEMP	STEAM	FLOW	H	2500.	L	0.	PCM	3
06	TE332	45.F	XXX	SGS	TURBIN	THROTL	TEMP	H	990.	L	910.	PCM	3
07	TE331	193.F	XXX	SGS	SPRHTR	STEAM	OUTLET	H	1200.	L	910.	PCM	3
08	PT321	0.PSI	XXX	SGS	STEAM	DLIVRY	PRESS	H	1150.	L	950.	PCM	2
09	PT386	0.PSI	XXX	SGS	FEED	WATER	PRESS	H	1500.	L	0.	PCM	3
10	TE386	66.F	XXX	HRFS	FEED	WATER	TEMP	H	575.	L	500.	PCM	3
11	TE388	245.F	XXX	SGS	EVAPTR	WATER	TEMP	H	1100.	L	500.	PCM	3
12	ZT411	.0PCT	XXX	HRFS	FCV411	VALVE	POS	H	100.0	L	.0	PCM	3
13	ZT331	.0PCT	XXX	SGS	FCV331	VALVE	POS	H	100.0	L	.0	PCM	3
14	ZSH384	1.ON	XXX	SGS	ELECT	HEATER	STRUP					PCM	3
15	ZSL384	0.OFF	XXX	SGS	ELECT	HEATER	STRUP					PCM	3
16	FCV401	18.PSI	XXX	HRFS	FDWATR	PUMP	PRESS	H	1500.	L	0.	PCM	2
17	FCV421	89.F	XXX	HRFS	FDWATR	TEMP	CONTRL	H	2500.	L	-99.	PCM	2
18	FCV431	.0PCT	XXX	HRFS	STEAM	CONTRL		H	100.0	L	.0	PCM	2
19	FCV432	1.PSI	XXX	DEATOR	OPRTNG	PRESS	CONTRL	H	400.	L	0.	PCM	2
20	FCV491	0.PSI	XXX	SGS	STEAM	DLIVRY	PRESS	H	1150.	L	950.	PCM	2
21	LT471	27.4IN	XXX	HRFS	DEATOR	LEVEL	CONTRL	H	30.0	L	10.0	PCM	2

GROUP 14  
26-NOV-84 16:57:25

COPY

F-23

01	TE382	3. PSI	SGS	SPRHTR	SALT	INLET	H	200.	L	0.	PCM	3	
02	TE382	372. F	XXX	SGS	SPRHTR	SALT	INLET	H	1070.	L	500.	PCM	3
03	TE301	423. F	XXX	SGS	EVAPTR	SALT	INLET	H	880.	L	500.	PCM	3
04	TE384	412. F	XXX	SGS	EVAPTR	SALT	OUTLET	H	640.	L	500.	PCM	3
05	PT384	0. PSI	XXX	SGS	EVAPTR	SALT	OUTLET	H	200.	L	0.	PCM	3
06	FT382	2.64KLB	XXX	SGS	COLD	BYPASS	FLOW	H	16.00	L	.00	PCM	3
07	FT321	4.8KLB	XXX	SGS	TOTAL	SALT	FLOW	H	100.0	L	.0	PCM	3
08	ZT301	62.1PCT	XXX	SGS	FCV301	VALVE	POS	H	100.0	L	.0	PCM	3
09	ZT321	100.0PCT	XXX	SGS	FCV321	VALVE	POS	H	100.0	L	.0	PCM	3
10	ZT341	.0PCT	XXX	SGS	FCV341	VALVE	POS	H	100.0	L	.0	PCM	3
11	ZT351	.0PCT	XXX	SGS	FCV351	VALVE	POS	H	100.0	L	.0	PCM	3
12	FCV221	34.8IN	XXX	TSS	HOT	SUMP	LEVEL	H	100.0	L	.0	PCM	3
13	FCV201	33.9IN	XXX	TSS	COLD	SUMP	LEVEL	H	60.0	L	15.0	PCM	3
14	PT180	0. PSI	XXX	RCYR	BOOST	PUMP	DSCHGE	H	400.	L	275.	PCM	3
15	LT281	119.1IN	XXX	TSS	COLD	TANK	LEVEL	H	134.0	L	15.0	PCM	3
16	LT291	.0IN	XXX	TSS	HOT	TANK	LEVEL	H	190.0	L	10.0	PCM	3
17	PT383	8. PSI	XXX	SGS	STEAM	DRUM	PRESS.	H	1250.	L	950.	PCM	3
18	FT311	.01KLB	XXX	SGS	MAIN	STEAM	FLOW	H	12.60	L	3.20	PCM	3
19	FT411	.01KLB	XXX	HRFS	FEED	WATER	FLOW	H	16.00	L	.00	PCM	3
20	LT311	22.8IN	XXX	SGS	STEAM	DRUM	WATER	H	4.0	L	-4.0	PCM	3
21	TE387	57. F	XXX	HOT	SALT	PUMP	BEARNG	H	190.	L	-99.	PCM	3
22	TE385	100. F	XXX	TSS	COLD	PUMP	BEARNG	H	190.	L	-99.	PCM	3

F-24

GROUP 15



01	ESH1	0. OFF	SGS	ELECT	HEATER NO. 1	PCM	3	
02	ESH2	0. OFF	SGS	ELECT	HEATER NO. 2	PCM	3	
03	ESH3	0. OFF	SGS	ELECT	HEATER NO. 3	PCM	3	
04	ESH4	0. OFF	SGS	ELECT	HEATER NO. 4	PCM	3	
05	ESH5	0. OFF	SGS	ELECT	HEATER NO. 5	PCM	3	
06	EHAC	0. OFF	SGS	CIRC	HEATER CONTRL	PCM	3	
07	MAN. EHAC	0. OFF	SGS	CIRC	HEATER CONTRL	PCM	3	
08	MAN. ESH1	0. OFF	SGS	ELECT	HEATER NO. 1	PCM	3	
09	MAN. ESH2	0. OFF	SGS	ELECT	HEATER NO. 2	PCM	3	
10	MAN. ESH3	0. OFF	SGS	ELECT	HEATER NO. 3	PCM	3	
11	MAN. ESH4	0. OFF	SGS	ELECT	HEATER NO. 4	PCM	3	
12	MAN. ESH5	0. OFF	SGS	ELECT	HEATER NO. 5	PCM	3	
F:25								
13	EH1. ON	0. OFF	XXX	SGS	ELECT	HEATER NO. 1	PCM	3
14	EH2. ON	0. OFF	XXX	SGS	ELECT	HEATER NO. 2	PCM	3
15	EH3. ON	0. OFF	XXX	SGS	ELECT	HEATER NO. 3	PCM	3
16	EH4. ON	0. OFF	XXX	SGS	ELECT	HEATER NO. 4	PCM	3
17	EH5. ON	1. ON	XXX	SGS	ELECT	HEATER NO. 5	PCM	3
18	MAN. BWCP	0. OFF	SGS	WATER	CIRC PUMP	PCM	3	
19	BWCP	0. OFF	SGS	WATER	CIRC PUMP	PCM	3	
20	ZSHBCP	1. ON	XXX	SGS	BOILER CIRC	PUMP	PCM	3

COPY

GROUP 16  
26-NOV-84 17:00:16

01	ZSH381	0. OFF	XXX	SGS	EVAP	DRAIN														
02	ZSL381	1. ON	XXX	SGS	EVAP	DRAIN														
03	ZSH382	0. OFF	XXX	SGS	SUPER	HEATER	DRAIN													
04	ZSL382	1. ON	XXX	SGS	SUPER	HEATER	DRAIN													
05	ZSH383	0. OFF	XXX	SGS	ELECT	HEATER	BYPASS													
06	ZSL383	1. ON	XXX	SGS	ELECT	HEATER	BYPASS													
07	ZSH384	1. ON	XXX	SGS	ELECT	HEATER	STRUP													
08	ZSL384	0. OFF	XXX	SGS	ELECT	HEATER	STRUP													
09	ZSL491	1. ON	XXX	HRFS	STEAM	SHUT	OFF													
10	ZT301	61.7PCT	XXX	SGS	FCV301	VALVE	POS	H	100.0	L		.0	PCM							
11	ZT321	100.0PCT	XXX	SGS	FCV321	VALVE	POS	H	100.0	L		.0	PCM							
12	ZT341	.0PCT	XXX	SGS	FCV341	VALVE	POS	H	100.0	L		.0	PCM							
13	ZT351	.0PCT	XXX	SGS	FCV351	VALVE	POS	H	100.0	L		.0	PCM							

F-26

COPY

01	FCV421	89.F	XXX	HRFS	FWATR	TEMP	CONTRL	H	2500.	L	-99.	PCM	2
02	FCV431	.0PCT	XXX	HRFS	STEAM	CONTRL		H	100.0	L	.0	PCM	2
03	FCV432	1.PSI	XXX	DEATOR	OPRTNG	PRESS	CONTRL	H	400.	L	.0	PCM	2
04	FCV471	27.4IN	XXX	HRFS	DEATOR	LEVEL	CONTRL	H	30.0	L	10.0	PCM	2
05	FY472	27.4IN	XXX	HRFS	MAKEUP	PUMP	STROKE	H	30.0	L	10.0	PCM	2
06	H1	196.F		HRFS	DEATOR	HEATER	CONTRL	H	750.	L	-300.	PCM	2
07	H2	196.F		HRFS	DEATOR	HEATER	CONTRL	H	750.	L	-300.	PCM	2
08	EN.H1	0.OFF		HRFS	ENABLE	DEATER	HEATER					PCM	2
09	EN.H2	0.OFF		HRFS	ENABLE	DEATER	HEATER					PCM	2
10	ZSHH1	0.OFF	CFN	HRFS	DD	HTR1	STATUS					PCM	2
11	ZSHH2	0.OFF	CFN	HRFS	DD	HTR2	STATUS					PCM	2
12	PT431	6.PSI	XXX	HRFS	HIGH	PRESS	STEAM	H	1200.	L	900.	PCM	2
13	TE483	73.F	XXX	HRFS	HIGH	PRESS	STEAM	H	990.	L	850.	PCM	2
14	PT481	17.PSI	XXX	HRFS	FWATR	PUMP	SUPPLY	H	400.	L	170.	PCM	2
15	PT482	5.PSI	XXX	HRFS	SPRAY	WATER	PRESS	H	300.	L	200.	PCM	2
16	TE482	143.F	XXX	HRFS	SPRAY	WATER	TEMP	H	445.	L	-300.	PCM	2
17	PT483	0.PSI	XXX	HRFS	FWATR	PRESS		H	1230.	L	1180.	PCM	2
18	FCV483	0.OFF		HRFS	DEATOR	VENT	NO.1					PCM	2
19	FCV484	0.OFF		HRFS	DEATOR	VENT	NO.2					PCM	2
20	FCV491	0.PSI	XXX	SGS	STEAM	DLIVRY	PRESS	H	1150.	L	950.	PCM	2

F-27

COPY

GROUP 18  
26-NOV-84 17:03:16

F-28

01	FWP	0. OFF	HRFS	FEED	WATER	PUMP				PCM
02	FWP .EN	0. OFF	HRFS	FWP	ENABLE					PCM
03	SWP	0. OFF	HRFS	SPRAY	WATER	PUMP				PCM
04	SWP .EN	0. OFF	HRFS	SWP	ENABLE					PCM
05	CWP	0. OFF	HRFS	COOLNG	WATER	PUMP				PCM
06	CWP .EN	0. OFF	HRFS	CWP	ENABLE					PCM
07	CMP	0. OFF	HRFS	COND	MAKEUP	PUMP				PCM
08	CMP .EN	0. OFF	HRFS	CMP	ENABLE					PCM
09	CFP	0. OFF	HRFS	CYCLE	FILL	PUMP				PCM
10	CFP .EN	0. OFF	HRFS	CFP	ENABLE					PCM
11	ZSHFWP	0. OFF	XXX	HRFS	FEED	WATER	PUMP			PCM
12	ZSHSWP	0. OFF	XXX	HRFS	SPRAY	WATER	PUMP			PCM
13	ZSHCWP	0. OFF	XXX	HRFS	COOLNG	WATER	PUMP			PCM
14	ZSHCMP	0. OFF	XXX	HRFS	COND	MAKEUP	PUMP			PCM
15	ZSHCFP	1. ON	XXX	HRFS	CYCLE	FILL	PUMP			PCM
16	LT471	27.4 IN	XXX	HRFS	DEATOR	LEVEL	CONTRL	H	30.0 L	10.0 PCM
17	FT481	4. KLB	XXX	HRFS	FEED	SPRAY	WATER	H	160. L	0. PCM
18	FT482	1. KLB	XXX	HRFS	SPRAY	WATER	FLOW	H	160. L	0. PCM

COPY

01	CF1	0.OFF	HRFS	COOLNG	TOWER	FANS						PCM
02	CF2	0.OFF	HRFS	COOLNG	TOWER	FANS						PCM
03	CF3	0.OFF	HRFS	COOLNG	TOWER	FANS						PCM
04	CF4	0.OFF	HRFS	COOLNG	TOWER	FANS						PCM
05	CF5	0.OFF	HRFS	COOLNG	TOWER	FANS						PCM
06	CF6	0.OFF	HRFS	COOLNG	TOWER	FANS						PCM
07	CF1.EN	0.OFF	HRFS	CF1	ENABLE							PCM
08	CF2.EN	0.OFF	HRFS	CF2	ENABLE							PCM
09	CF3.EN	0.OFF	HRFS	CF3	ENABLE							PCM
10	CF4.EN	0.OFF	HRFS	CF4	ENABLE							PCM
11	CF5.EN	0.OFF	HRFS	CF5	ENABLE							PCM
12	CF6.EN	0.OFF	HRFS	CF6	ENABLE							PCM
13	ZSHCF1	0.OFF	XXX	HRFS	COOLNG	TOWER	FANS					PCM
14	ZSHCF2	0.OFF	XXX	HRFS	COOLNG	TOWER	FANS					PCM
15	ZSHCF3	0.OFF	XXX	HRFS	COOLNG	TOWER	FANS					PCM
16	ZSHCF4	0.OFF	XXX	HRFS	COOLNG	TOWER	FANS					PCM
17	ZSHCF5	0.OFF	XXX	HRFS	COOLNG	TOWER	FANS					PCM
18	ZSHCF6	0.OFF	XXX	HRFS	COOLNG	TOWER	FANS					PCM
19	TE484	46.F	XXX	HRFS	C.W.	CNDR	OUT	H	130.	L	-300.	PCM
20	TE485	524.F	BAD	HRFS	C.W.	SMHX	OUT	H	110.	L	32.	PCM
21	TE486	40.F	XXX	HRFS	C.W.	TWR	OUT	H	110.	L	32.	PCM

F-28

COPY

GROUP 20  
27-NOV-84 07:21:13

NO	UNIT	STATUS	UNIT	UNIT	UNIT	UNIT	UNIT	UNIT	UNIT	UNIT	UNIT	
01	EN.HLC	0.OFF	XXX	ENABLE	HOTWEL	LEVEL	CONTRL				PCM	
03	FCV471	27.6IN	XXX	HRFS	DEATOR	LEVEL	CONTRL	H	30.0	L	10.0	PCM
04	FCV511	0.OFF		EPGS	COND	DUMP						PCM
05	FCV512	0.OFF		EPGS	COND	MAKEUP						PCM
06	FCV521	48.F	XXX	EPGS	OIL	COOLER	TEMP	H	500.	L	0.	PCM
07	CTP	0.OFF		EPGS	COOLNG	TOWER	PUMP					PCM
08	CTP.EN	0.OFF		EPGS	CTP	ENABLE						PCM
09	CTF	0.OFF		EPGS	COOLNG	TOWER	FANS					PCM
10	CTF.EN	0.OFF		EPGS	CTF	ENABLE						PCM
11	CNP	0.OFF		EPGS	COND	PUMP						PCM
12	CNP.EN	0.OFF		EPGS	CNP	ENABLE						PCM
13	AEP	0.OFF		EPGS	AIR	XHAUST	PUMP					PCM
14	AEP.EN	0.OFF		EPGS	AEP	ENABLE						PCM
15	EOP	0.OFF		EPGS	ELECT	OIL	PUMP					PCM
16	EOP.EN	0.OFF		EPGS	EOP	ENABLE						PCM
17	ZSHCTP	0.OFF	XXX	EPGS	COOLNG	TOWER	PUMP					PCM
18	ZSHCTF	0.OFF	COS	EPGS	COOLNG	TOWER	FANS					PCM
19	ZSHCNP	0.OFF	XXX	EPGS	COND	PUMP	ON					PCM
20	ZSHAEP	0.OFF	XXX	EPGS	AIR	XHAUST	PUMP					PCM
21	ZSHEOP	0.OFF	XXX	EPGS	ELECT	OIL	PUMP					PCM

COPY

01	02	03	04	05	06	07	08	09	10	11	12	13	14	15	16	17	18	19	20	21	22	
01	ETR	0. OFF		EPGS	EMER	TRIP	RESET															
02	PT581	0. PSI	XXX	EPGS	TURBIN	STEAM	PRESS	H	1500.	L	800.											
03	TT583	49. F	XXX	EPGS	TURBIN	STEAM		H	990.	L	800.											
04	ST582	0. RPM	XXX	EPGS	GEN	SPEED		H	1270.	L	0.											
05	FCV501	0. OFF		EPGS	TURBIN	STOP																
06	ZSH501	0. OFF	XXX	EPGS	TURBIN	STOP	VALVE															
07	ZSL501	1. ON	XXX	EPGS	TURBIN	STOP	VALVE															
08	TVM.OPN	0. OFF		EPGS	THROTL	VALVE	MOTOR															
09	TVM.CLS	0. OFF		EPGS	THROTL	VALVE	MOTOR															
10	ZTTVM	0. PCT		EPGS	THROTL	VALVE	POS	H	100.0	L	0.											
11	PT582	0. PSI	XXX	EPGS	STEAM	SEAL	PRESS	H	150.	L	0.											
12	PT502	23.9 IN	XXX	EPGS	CONDSR	PRESS		H	10.0	L	0.											
13	LT511	9.1 IN	XXX	EPGS	HOT	WELL	LEVEL	H	16.0	L	8.0											
14	PT501	0. PSI	XXX	EPGS	OIL	SUPPLY	PRESS	H	40.	L	10.											
15	PT531	0. PSI	XXX	EPGS	HYDRO	OIL	PRESS	H	120.	L	55.											
16	TT501	48. F	XXX	EPGS	TURBIN	OUTBD	BEARNG	H	170.	L	110.											
17	TT502	64. F	XXX	EPGS	TURBIN	INBD	BEARNG	H	170.	L	110.											
18	TE503	59. F	XXX	EPGS	TURBIN	OUTBD	GEAR	H	170.	L	110.											
19	TE505	65. F	XXX	EPGS	GEN	OUTBD	GEAR	H	170.	L	110.											
20	TE506	60. F	XXX	EPGS	GEN	INBD	GEAR	H	170.	L	110.											
21	A2T581	.3 PCT	XXX	EPGS	TURBIN	VIBRAT	0...5G	H	60.0	L	0.											

GROUP 22

COPY

01	UT581	0. NU	XXX	EPGS	POWER	0. 960	NUMA'S	H	960	L	0.	PCM	2
02	ET581	0. VAC	XXX	EPGS	VOLTS			H	465.	L	445.	PCM	2
03	ST582	0. RPM	XXX	EPGS	GEN	SPEED		H	1270.	L	0.	PCM	2
04	ST581	0. PCT	XXX	EPGS	FREQ	55.65 HERTZ		H	60.0	L	40.0	PCM	2
05	IT581	0. AMP	XXX	EPGS	CURRNT			H	1200.	L	0.	PCM	2
06	PFT581	1.00 LAG	XXX	EPGS	POWER	FACTOR		H	1.00	L	.85	PCM	2
07	VT581	0. VAR	XXX	EPGS	VARS	0.960 KVAR		H	500.	L	0.	PCM	2
08	TT507	45. F	XXX	EPGS	GEN	OUTBD	BEARNG	H	170.	L	110.	PCM	2
09	TE508	42. F	XXX	EPGS	GEN	AIR	TEMP	H	100.	L	-300.	PCM	2
10	TT510	0. F	XXX	EPGS	STATOR	WINDNG	1	H	260.	L	0.	PCM	2
11	TT511	0. F	XXX	EPGS	STATOR	WINDNG	2	H	260.	L	0.	PCM	2
12	TT512	0. F	XXX	EPGS	STATOR	WINDNG	3	H	260.	L	0.	PCM	2
13	TT513	0. F	XXX	EPGS	STATOR	WINDNG	4	H	260.	L	0.	PCM	2
14	TT514	0. F	XXX	EPGS	STATOR	WINDNG	5	H	260.	L	0.	PCM	2
15	TT515	0. F	XXX	EPGS	STATOR	WINDNG	6	H	260.	L	0.	PCM	2

28-1

COPY

GROUP 23  
27-NOV-84 07:26:12



	TRIP	STATUS	UNIT	DESCRIPTION	FUNCTION	PCN	PCN
01	EPS1.RST	0.OFF	EPS	RESET	FROM	PCN1	PCN1
02	EPS2.RST	0.OFF	EPS	RESET	FROM	PCN2	PCN2
03	EPS3.RST	0.OFF	EPS	RESET	FROM	PCN3	PCN3
04	TR181	0.OFF	COS	RCVR	SALT	HIGH	TEMP
05	TR183	0.OFF	COS	RCVR	INLET	PRESS	LOW
06	TR184	0.OFF	COS	RCVR	TUBE	HIGH	TEMP
07	TR185	0.OFF	COS	RCVR	HTANK	HIGH	LEVEL
08	TR182	0.OFF	COS	BOOST	PUMP	LOW	PRESS
09	TR186	0.OFF	COS	BOOST	PUMP	SUMP	LEVEL
10	TR281	0.OFF	COS	HOT	SUMP	HIGH	LEVEL
11	TR282	0.OFF	COS	COLD	SUMP	HIGH	LEVEL
12	TR381	0.OFF	COS	SGS	DRUM	LEVEL	LO.LO
13	TR382	0.OFF	COS	SGS	WATER	RECIRC	PUMP
14	TR383	1.ON	COS	SGS	DRUM	LEVEL	HI.HI
15	TR582	0.OFF	COS	EPGS	MANUAL	TRBGEN	TRIP
16	TR583	0.OFF	COS	EPGS	OIL	PRESS	LOW
17	TR584	0.OFF	COS	EPGS	GEN	BEARNG	TEMP
18	TR585	0.OFF	COS	EPGS	GEN	AIR	TEMP
19	TR586	0.OFF	COS	EPGS	GEN	BRKR	TRIP
20	TR587	0.OFF	COS	EPGS	VIBRAT	HIGH	
21	TR588	0.OFF	COS	EPGS	STEAM	ENERGY	LOW
22	VIB.OVR	0.OFF		EPGS	VIBRAT	OVERRIDE	

F-38

COPY

01	OVRS1	0.OFF	XXX	PCM3	INTRLK	OVRRIDE						PCM	1
02	OVR3	0.OFF	XXX	PCM3	INTRLK	OVRRIDE						PCM	3
03	SCRAM	1.ON		HELIO	SCRAM							PCM	1
04	RCAR	0.OFF	COS	RCVR	ALGORM	RESET	ALARM					PCM	1
05	GSTAT	0.OFF	COS	GEN	ONLINE	FCV431	CONTRL					PCM	2
06	ELO1	0.OFF	COS	EMCON	LOKOUT	HOT	SURGE					PCM	1
07	ELO3A	0.OFF	COS	EMCON	LOKOUT	HOT	SURGE					PCM	3
08	ELO3B	0.OFF	COS	EMCON	LOKOUT	COLD	SUMP					PCM	3
09	ELO3C	0.OFF	COS	EMCON	LOKOUT	HOT	SUMP					PCM	3
10	LV181	1.ON	XXX	24VDC	CONTRL	POWER	SUPPLY					PCM	1
11	LV281	1.ON	XXX	24VDC	CONTRL	POWER	SUPPLY					PCM	3
12	N90.PS	1.OK	XXX	NETWRK	90	POWER	SUPPLY					PCM	3
13	N90.ALM	0.ALM	XXX	NETWRK	90	ALARM						PCM	3
14	LV481	1.ON	XXX	24VDC	CONTRL	POWER	SUPPLY					PCM	2
15	CA161	.0IN	XXX	RCVR	HOT	SURGE	TANK	H	100.0	L	.0	PCM	3
16	RD101	.0KLB	XXX	RCVR	FLOW	DEMAND	CALC	H	100.0	L	.0	PCM	1
17	ALGPID	.0KLB	XXX	RCVR	ALG	PID	BLOCK	H	100.0	L	.0	PCM	1
18	CA101C	.0KLB	XXX	CALC	BLOCK			H	100.0	L	.0	PCM	1

F34

01	VAL	UNIT	GEN	ALARMS									
02	LT201	34.0IN	XXX TSS	COLD SUMP	LEVEL	H	60.0	L	15.0	PCM	3		
03	LT221	35.1IN	XXX TSS	HOT SUMP	LEVEL	H	41.0	L	15.0	PCM	3		
04	LT281	118.6IN	XXX TSS	COLD TANK	LEVEL	H	134.0	L	15.0	PCM	3		
05	LT291	.0IN	XXX TSS	HOT TANK	LEVEL	H	190.0	L	10.0	PCM	3		
06	LT311	-17.0IN	XXX SGS	STEAM DRUM	WATER	H	4.0	L	-4.0	PCM	3		
07	LT471	27.7IN	XXX HRFS	DEATOR	LEVEL	H	30.0	L	10.0	PCM	2		
08	LT511	9.1IN	XXX EPGS	HOT WELL	LEVEL	H	16.0	L	8.0	PCM	2		
09	TE180	68.F	XXX BOOST	PUMP BEARNG	TEMP	H	190.	L	-99.	PCM	3		
10	TE181	152.F	XXX BOOST	PUMP SUMP	VENT	H	350.	L	-99.	PCM	3		
11	TE184	557.F	XXX RCVR	HOT SURGE	VENT	H	400.	L	-99.	PCM	1		
12	TE211	82.F	XXX TSS	COLD SUMP	VENT	H	400.	L	-99.	PCM	3		
13	TE231	69.F	XXX TSS	HOT SUMP	VENT	H	400.	L	-99.	PCM	3		
14	TE281	539.F	XXX TSS	CTANK RAKE	LOWER	H	750.	L	500.	PCM	3		
15	TE286	116.F	XXX TSS	COLD PUMP	BEARNG	H	190.	L	-99.	PCM	3		
16	TE383	279.F	XXX SGS	STEAM DRUM	FLUID	H	575.	L	500.	PCM	3		
17	TE387	69.F	XXX HOT	SALT PUMP	BEARNG	H	190.	L	-99.	PCM	3		
18	TE388	252.F	XXX SGS	EVAPTR WATER	TEMP	H	1100.	L	500.	PCM	3		
19	TE481	186.F	XXX HRFS	DEATOR STEAM	TEMP	H	400.	L	300.	PCM	2		
20	TE484	46.F	XXX HRFS	C.W. CNDR	OUT	H	130.	L	-300.	PCM	2		
21	TE486	40.F	XXX HRFS	C.W. TWR	OUT	H	110.	L	32.	PCM	2		
22	TE508	42.F	XXX EPGS	GEN AIR	TEMP	H	100.	L	-300.	PCM	2		

COPY

GROUP 28  
27-NOV-84 07:33:58

01	TE581	48. F	XXX	EPGS	GEN	AIR	TEMP	H	180. L	0.	PCM	3
02	TE581	48. F	XXX	EPGS	TURB	EXH	TEMP	H	180. L	0.	PCM	3
03	LS541	0. OFF	XXX	EPGS	COND	STORAG	LOW				PCM	3
04	PS281	1. ON	XXX	TSS	SGS	AIR	SUPPLY				PCM	3
05	PS485	0. OFF	XXX	HRFS	AIR	SUPPLY					PCM	3
06	TS501	0. OFF	XXX	EPGS	BEARNG	TEMP	HI				PCM	3
07	TS502	0. OFF	XXX	EPGS	AIR	TEMP	HI				PCM	3
08	LV281	1. ON	XXX	24VDC	CONTRL	POWER	SUPPLY				PCM	3
09	LV481	1. ON	XXX	24VDC	CONTRL	POWER	SUPPLY				PCM	3
10	N90.PS	1. OK	XXX	NETWRK	90	POWER	SUPPLY				PCM	3
11	N90.ALM	0. ALM	XXX	NETWRK	90	ALARM					PCM	3

F-36

COPY

GROUP 29  
27-NOV-84 07:35:15

01	SNL	UNIT	SGS	ALARM	DESCRIPTION	UNIT	SCALE	UNIT	SCALE	UNIT	SCALE
02	TE301	461.F	XXX	SGS	EVAPTR SALT	INLET	H	880.	L	500.	PCM 3
03	TE331	225.F	XXX	SGS	SPRHTR STEAM	OUTLET	H	1200.	L	910.	PCM 3
04	TE332	45.F	XXX	SGS	TURBIN THROTL	TEMP	H	990.	L	910.	PCM 3
05	TE382	391.F	XXX	SGS	SPRHTR SALT	INLET	H	1070.	L	500.	PCM 3
06	TE384	494.F	XXX	SGS	EVAPTR SALT	OUTLET	H	640.	L	500.	PCM 3
07	TE386	242.F	XXX	HRS	FEED WATER	TEMP	H	575.	L	500.	PCM 3
08	TE421	65.F	XXX	HRFS	FDWATR	TEMP	H	600.	L	400.	PCM 2
09	TE483	73.F	XXX	HRFS	HIGH PRESS	STEAM	H	990.	L	850.	PCM 2
10	PT321	29.PSI	XXX	SGS	STEAM DLIVRY	PRESS	H	1150.	L	950.	PCM 2
11	PT384	0.PSI	XXX	SGS	EVAPTR SALT	OUTLET	H	200.	L	0.	PCM 3
12	PT386	0.PSI	XXX	SGS	FEED WATER	PRESS	H	1500.	L	0.	PCM 3
13	PT431	6.PSI	XXX	HRFS	HIGH PRESS	STEAM	H	1200.	L	900.	PCM 2
14	PT432	1.PSI	XXX	HRFS	DEATOR	PRESS	H	250.	L	200.	PCM 2
15	PT483	0.PSI	XXX	HRFS	FDWATR	PRESS	H	1230.	L	1180.	PCM 2

F-37

COPY

GROUP 31  
27-NOV-84 07:36:40

01	VAL	UNIT	ALERT	POWER	ALARMS						
02	ET581	0. VAC	XXX	EPGS	VOLTS		H	465.	L	445.	PCM
03	ST581	0PCT	XXX	EPGS	FREQ	55.65	HERTZ	H	60.0	L	40.0
04	ZSHAEP	0. OFF	XXX	EPGS	AIR	XHAUST	PUMP				PCM
05	TT501	48. F	XXX	EPGS	TURBIN	OUTBD	BEARNG	H	170.	L	110.
06	TT502	64. F	XXX	EPGS	TURBIN	INBD	BEARNG	H	170.	L	110.
07	TE503	59. F	XXX	EPGS	TURBIN	OUTBD	GEAR	H	170.	L	110.
08	TE505	64. F	XXX	EPGS	GEN	OUTBD	GEAR	H	170.	L	110.
09	TE506	59. F	XXX	EPGS	GEN	INBD	GEAR	H	170.	L	110.
10	TT507	45. F	XXX	EPGS	GEN	OUTBD	BEARNG	H	170.	L	110.
11	TT521	48. F	XXX	EPGS	OIL	COOLER	TEMP	H	140.	L	100.
12	TT583	48. F	XXX	EPGS	TURBIN	STEAM		H	990.	L	800.
13	PT501	0. PSI	XXX	EPGS	OIL	SUPPLY	PRESS	H	40.	L	10.
14	PT502	23.9IN	XXX	EPGS	CONDSR	PRESS		H	10.0	L	.0
15	PT531	0. PSI	XXX	EPGS	HYDRO	OIL	PRESS	H	120.	L	55.
16	PT581	0. PSI	XXX	EPGS	TURBIN	STEAM	PRESS	H	1500.	L	800.
17	PT583	.1PCT	XXX	HRFS	COND	PUMP	OUTPUT	H	65.0	L	23.0

867

COPY

GROUP 33  
27-NOV-84 07:38:45

ADDENDUM G  
RECEIVER FREEZE/THAW REPORT

August 15, 1984

To: W. R. Delameter, SNLL and E. De Meo, EPRI

Subject : Freeze up and thaw of MSEE Receiver, June 18-21, 1984

From: R. J. Holl, MDAC

Copies: J. Holmes, CRTF  
R. Cummings, Cummings Engineering

### Summary

Upon attempted receiver start-up on 18 June, it was impossible to establish serpentine flow through the receiver. This was due to a salt blockage caused by a substantial drop in lower header temperatures between the time they were checked in the pretest procedures, approximately 9 A.M., and the time of actual fill, approximately 12 noon. This delay was caused by spurious instrument readings which had to be corrected. Attempts were made throughout the day to free the blockage; they were hindered by intermittent cloudiness and were unsuccessful. After final afternoon shutdown, salt in receiver absorber tubes above the blocked header(s) froze because warm-up heliostats were removed. The receiver was configured with all purge and drain valves open in order to allow drainage of salt from any lower header that thawed over night by the trace heating (The lower header temperatures did reach nearly 500°F by 10 P.M.; however by this time the salt in the blocked receiver tubes was frozen at temperatures around 100°F to 200°F.)

Subsequent investigations established that six receiver panels were filled with frozen salt. Alternative methods for thawing the frozen panels were evaluated. Melting from the top, using near-in heliostats, was selected. Additional thermocouples were installed to help guide the melting operation. On 21 June, the frozen panels were successfully thawed. Subsequent operation and inspection showed no damage to the receiver.

The basic cause of the receiver freeze-up was the cooling of the lower headers between check-off and actual start-up. The start-up procedures have been revised to require checking all temperatures of salt lines and components immediately prior, within 15 minutes, to receiver fill. This will prevent a reoccurrence of this incident.



The daily events of this unplanned experiment are summarized below:

Monday, 18 June--Receiver Freeze-up

The sequence of major events is shown of Figure 1 superposed on the day's insolation. Table 1 gives the header temperatures and drain line temperatures that were recorded throughout the day. Clearly, the outlet of pass 10, channel number 23, was below freezing throughout the day although acceptable when checked in the morning. The outlet of pass 18, channel 26, dropped below freezing for most of the day but did not produce a freeze up of the panel. It can also be seen that the outlet header for pass 10 reached 489 °F by 21:43, so it undoubtedly drained. However, by this time the absorber panels had dropped to under 200 °F and the salt in them froze. Table 1 is illustrative of the problems that have been encountered in trying to maintain headers (and valves) above the salt freezing point. Subsequent erection of wind protection and some reinsulation has substantially improved this situation.

Figure one shows the efforts that were made throughout the day to free the blockage. The insolation drop out immediately following fill probably compounded the problem by allowing the salt in the low temperature headers to solidify before panel heating and valve cycling could be resumed.

The history of flow into the receiver is shown on Figure 2. The corresponding receiver inlet pressure is shown of Figure 3. Both figures indicate the cycling of the purge and drain valves that was done to attempt to clear the blockage. The flow through the receiver occurred when the valves allowed the blocked panels to be bypassed.

The initial indication of the blockage occurred at about 12:15 when, with the drain valves closed, the purge valves were cycled shut. This resulted in full pressure at the receiver inlet, PT181, which can be seen on Figure 3.

Figure 4 is a schematic of the receiver identifying the panels, the locations of Acurex channels 23-26 tabulated on Tabel 1 and the thermo-couple locations for the traces shown on Figures 5 through 8. Figure 5 shows the temperature history of TE-105 which is on Panel 3. This panel was not blocked and salt flow occurred whenever possible as shown by tracking the salt inlet temperature (600 °F) throughout the afternoon. Figure 6 illustrates a panel, panel 6, which was not filled with salt but which was blocked by a plug in an upstream header. Panel 9, shown on Figure 7, was filled with salt throughout the day. Note the smoother temperature

variations produced by the warm-up heliostats compared with Panel 6 which was empty. Figure 8 shows the temperature history of Panel 18 which is just above the header monitored by Channel 26 shown on Table 1. This panel did not block and received some bypassed flow (as did Panel 6) when the valves were properly positioned.

Following shut-down at about 16:00, all valves were positioned open to allow draining (and prevent rupturing) if the trace heat melted the headers overnight. Apparently the outlet of pass 10 melted as indicated on Table 1.

Tuesday, 19 June--Evaluation and Planning

On Tuesday morning, data were reviewed and the receiver was inspected. Tapping the panel tubes showed that panels 4, 5, 8, 9, 10 and 11 were filled with salt. These are shown on Figure 9.

The objective at this point was to melt the salt from one or the other end of the panels without melting or excessively heating it in the center. Since salt expands upon heating and melting, excessive expansion with both ends of the tubes plugged could have deformed or ruptured the tubes. The problem of melting from the ends was made more difficult due to insulation covering the tubes before they entered the headers--approximately 6 inches at the top and 10 inches at the bottom. Three methods of thawing the tubes were evaluated. They are listed below together with their advantages and disadvantages:

<u>Approach</u>	<u>Advantages</u>	<u>Disadvantages</u>
1. Melt salt from top with heliostats	1.a. Front, fully aligned heliostats have tight beam 1.b. Insulation is less than at bottom 1.c. Heat will rise	1.a. Could heat large region of absorber panels.
2. Melt salt from bottom with heliostats	2.a. Door could be covered with insulation board and lowered to provide narrow aperture for heating	2.a. Rear heliostats required--they have low intensity 2.b. Heat rises and will be trapped with lowered door. Could heat entire panel.

3. Install trace heat on floor of cavity; close door and heat	3.a. Controlled heat source	3.a. Likely to heat and expand entire salt volume
---------------------------------------------------------------------	--------------------------------	------------------------------------------------------

Since the first approach, melting from the top using heliostats, appeared most promising, a preliminary experiment was performed to determine the temperature gradient that could be developed from one, fully-aligned front heliostat. Tests were first conducted on empty panels. The results were encouraging so the test was repeated for filled panels. These results are shown on Figure 10. The thermocouples can be located on Figure 4. TE-111 is located on the back of Panel 9 within 6 inches of the top header. Hence it is just behind the bottom of the top insulation blanket. TE-133 is located on the back of the adjacent Panel 8 and is 48 inches from the top header. Thus the temperature gradient established on Figure 10 is over 42 inches. These panels were illuminated for the short periods indicated with a single heliostat (6 E2) with variations in the aim point. The results were:

<u>Pulse Number</u>	<u>Δ T (°F)</u>	
	<u>TE-111</u>	<u>TE-133</u>
1	101	56
2	101	19
3	68	5

This confirmed the precision with which fully-aligned, front heliostats could heat the panel.

Procedures were developed Tuesday evening to melt the frozen panels from the top down using heliostats.

Wednesday, 20 June--Preparation and Attempted Thaw

The approach and procedures prepared Tuesday were reviewed and approved Wednesday morning. Twelve additional thermocouples were installed on the front surface of the filled panels to aid in monitoring the thermal gradient during thaw. Their location is shown on Figure 11. Owen Scott of MMC calculated the diffusion of heat through the insulated top 6 inches of the panel from the heated absorber to the trace heated top header. His calculation considered conduction only along the 0.065 inch tube wall. Twelve minutes were sufficient to melt through if the exposed absorber tube was heated to just below melting. A period of one hour was allocated to this process in order to be extra conservative.

Following installation of the additional thermocouples, melting of the blocked panels was begun. It was interrupted once to reattach several of the added thermocouples. Additional trips occurred due to momentary loss of power and loss of EMCON's PCM-1. The latter trip occurred with approximately the top 3 to 4 feet of the blocked panels melted. Clouds prevented continued operations following restoration of PCM-1. Removal of the heliostat beam allowed the panels to again freeze.

Thursday, 21 June-- Receiver Thaw

Summer solstice was celebrated by successfully melting the frozen panels. A fairly uniform temperature gradient was established from the top down in all panels, whether filled or not. The process was begun by using one heliostat (6 E2) and changing its aim point. Following melt through of the top, insulated block, additional heliostats were used to maintain the melted region above the melting point and to extend the molten zone downward. A total of 262 individual heliostat commands were used for the thawing operation. The vertical temperature profiles during the thawing operation are shown of Figures 12 through 15. The apparent thermal gradient reversal at the panel location 66 inches from the upper header is exaggerated because this is an added front thermocouple which reads 50 °F or more higher than the corresponding rear tube temperatures read by the adjacent thermocouples. This same observation can be made about all front tube thermocouples which are located 12, 30, 66 and 102 inches from the top header.

Following melt through of the last panel, evidenced by a rapid increase in temperature of the lowest thermocouple as the molten salt from above passed through, the receiver was maintained hot for 30 minutes. It was shut down, briefly inspected and prepared for salt flow. After reheating and filling, the receiver was operated for 45 minutes at full flow and pressures. A careful inspection showed no damage at this time and none has appeared subsequent to this incident.

Table 1  
 Heater and Drain Line Temperatures  
 June 18, 1984 (Day 170)

Time	Event	Temperatures (°F)					
		<u>Acurex Channel Number</u>					
		<u>21</u>	<u>22</u>	<u>23</u>	<u>24</u>	<u>25</u>	<u>26</u>
		<u>Drain</u>	<u>Drain</u>	<u>Pass 1</u>	<u>Pass 2</u>	<u>Pass 3</u>	<u>Pass 4</u>
		<u>Line</u>	<u>Line</u>				
7:43		630	612	691	493	680	489
8:43		599	608	691	539	682	515
8:50	Check Temperatures						
9:43		574	602	700	393	699	430
10:43		564	605	699	355	706	419
11:43		559	603	709	381	713	334
12:00	First Fill						
12:15	First Drain						
12:43		547	570	572	352	700	375
13:09	Second Fill						
13:43		580	582	578	347	626	350
14:43		608	596	602	321	639	487
15:43		630	593	598	286	589	406
15:50	Second Drain						
16:43		489	584	307	332	535	189
17:43		456	579	241	282	490	141
21:43		479	506	260	489	605	89
23:43		458	504	179	309	531	136
5:43 (6/19)		580	552	375	597	626	520

12:00 BEGIN FILL  
 12:09 DRAIN & PURGE VALVES CLOSE  
 BLOCKAGE INDICATED  
 12:12 CLOSE DOOR  
 12:15 BEGIN DRAIN  
 12:58 OPEN DOOR  
 13:15 REFILL  
 13:39 CLOSE DOOR  
 13:49 OPEN DOOR  
 15:55 BEGIN DRAIN  
 CYCLE VALVES  
 CYCLE VALVES & HEAT

6-g

INSOLATION

W/SQ M  
1000.00  
800.00

600.00  
400.00  
200.00  
0.00

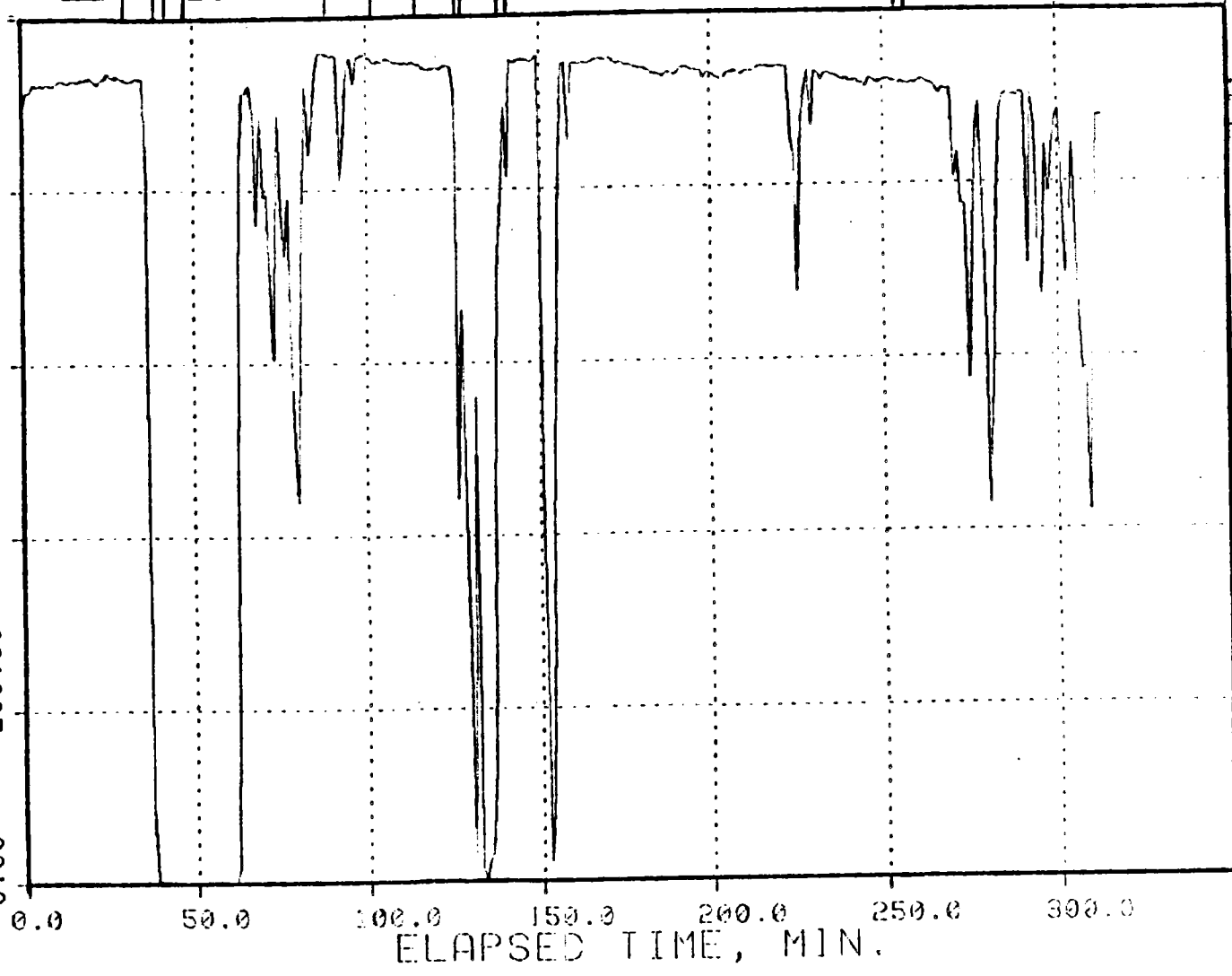

*Figure 1*

SEQUENCE  
OF EVENTS

DAY 170

FT101

DATA FILE MS170A

START TIME 1130.000

DAY = 170

NO. = 471

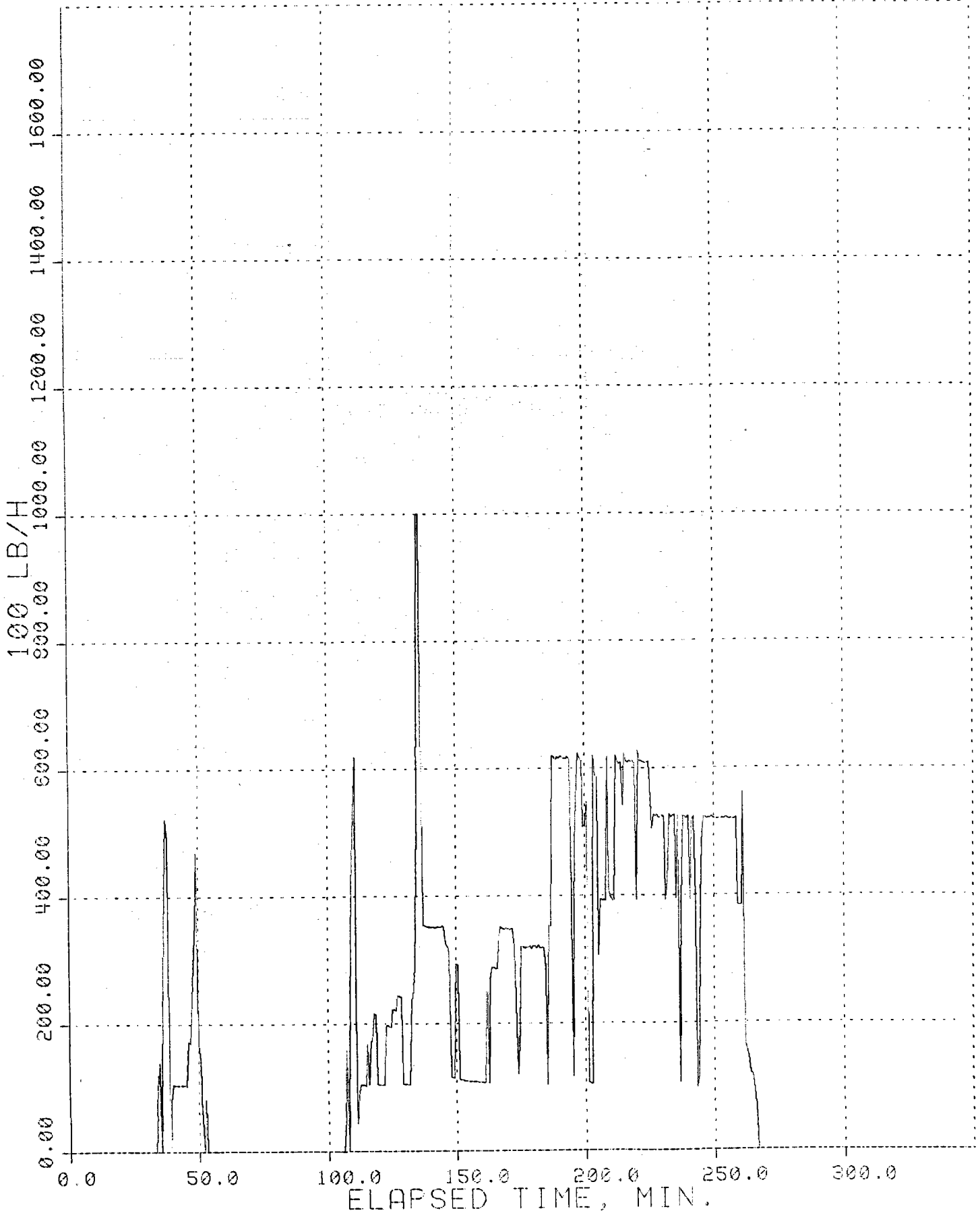

G-10

Figure 2

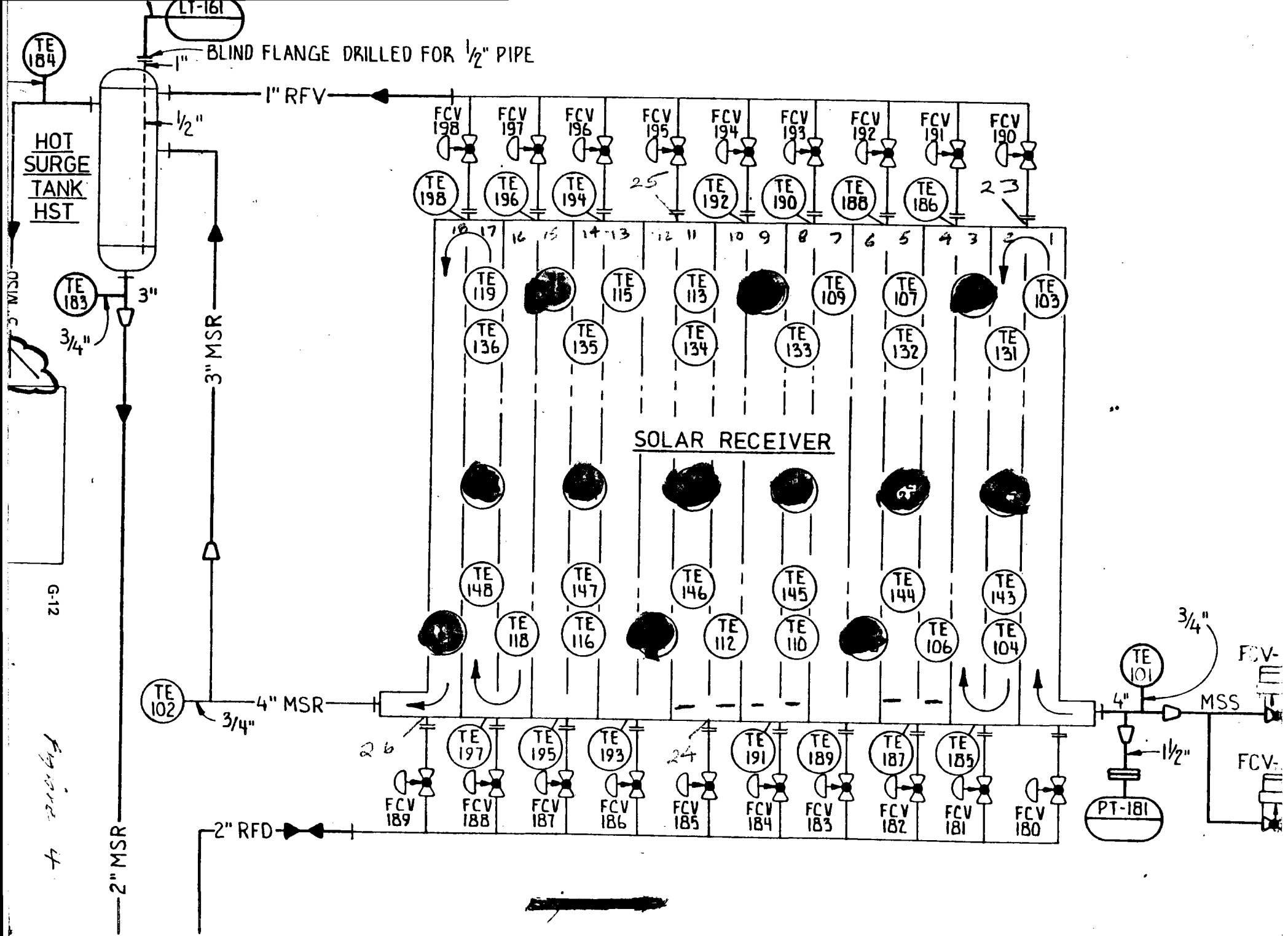

Figure 4



TE105 (panel 3)

DATA FILE MS170A  
START TIME 1130.000 DAY = 170

NO. = 471

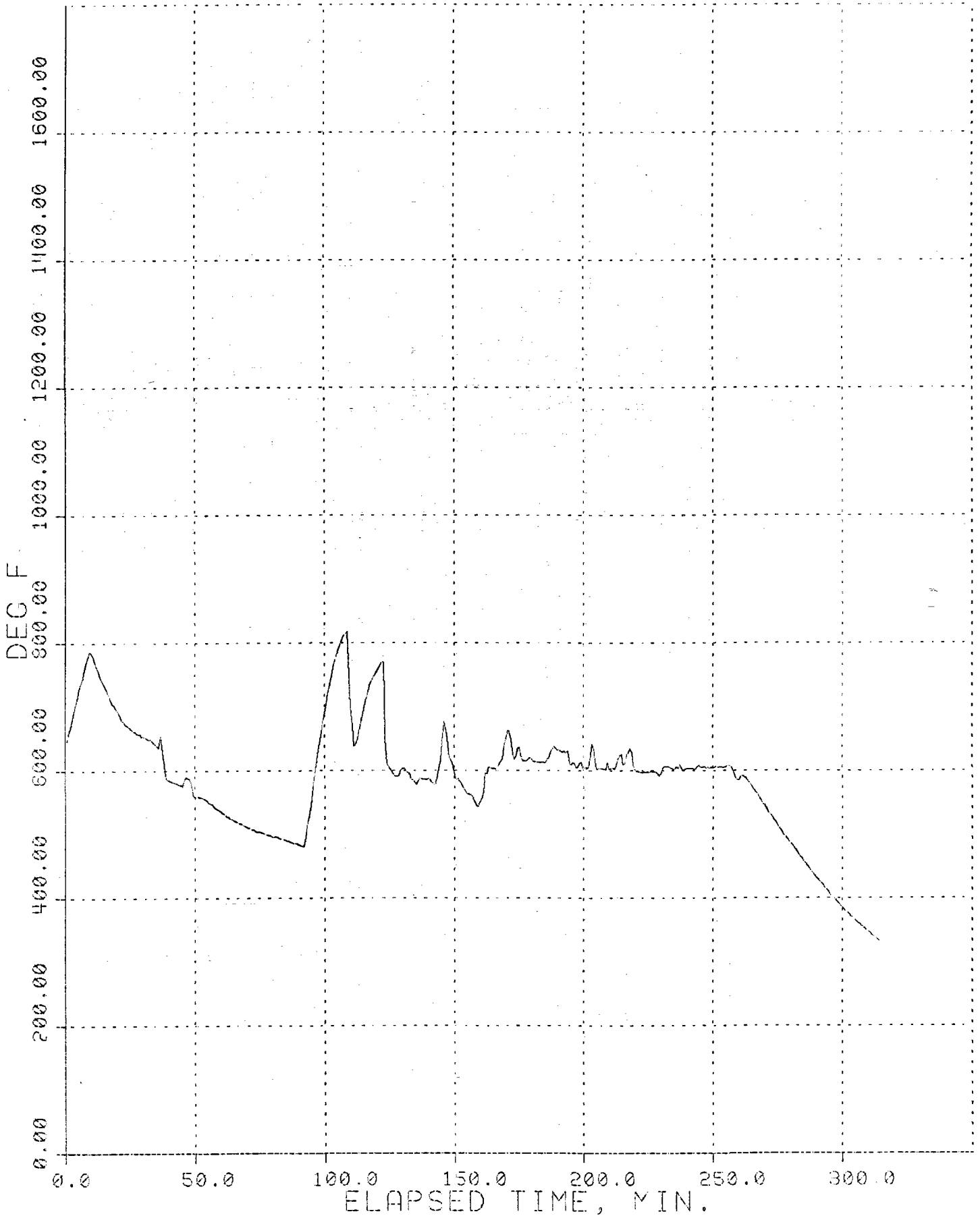

G-13

Figure 5

RECEIVER SALT BLUCKAGE

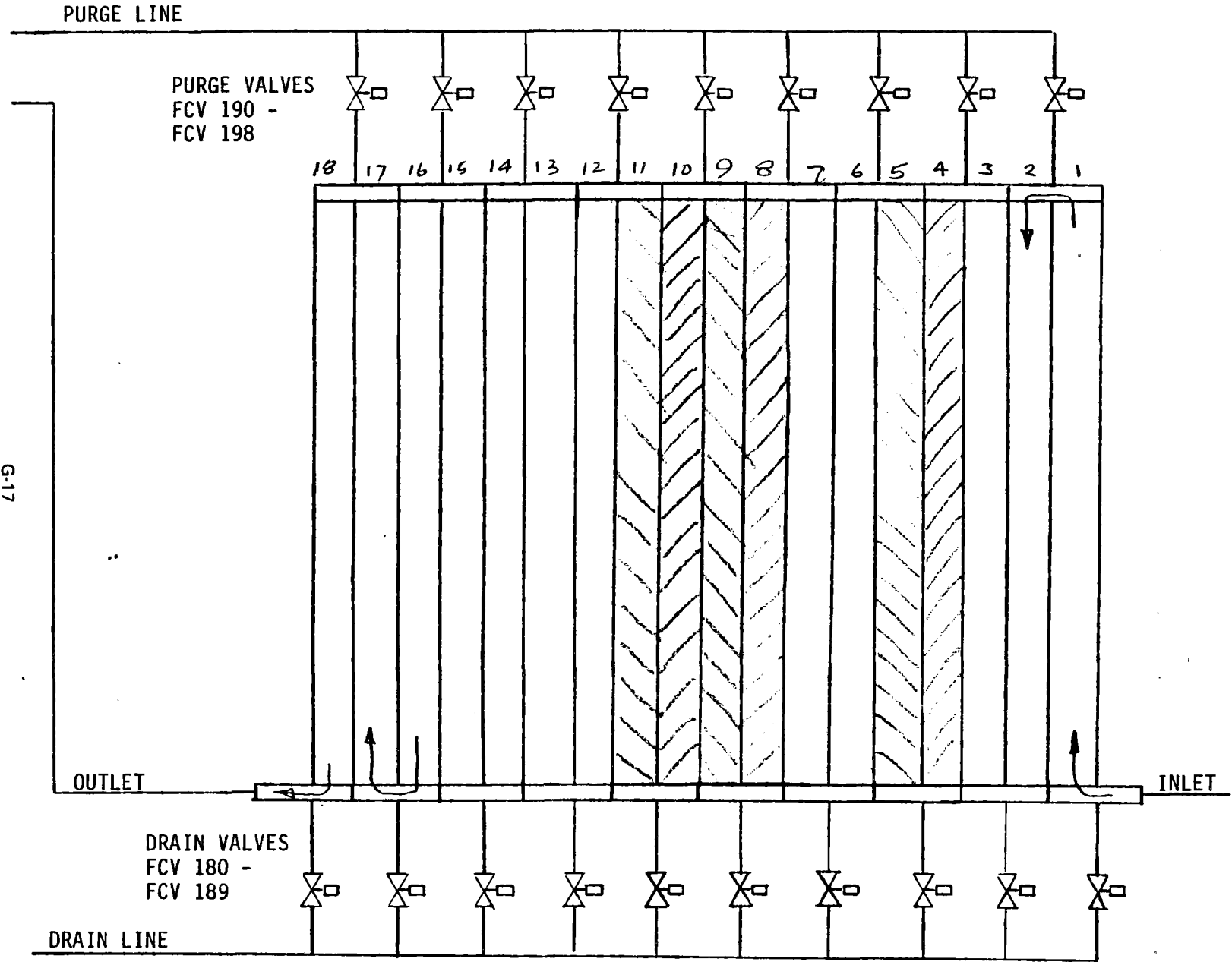

G-17

Figure 9

DATA FILE MS171A  
START TIME 1100.000 DAY = 171

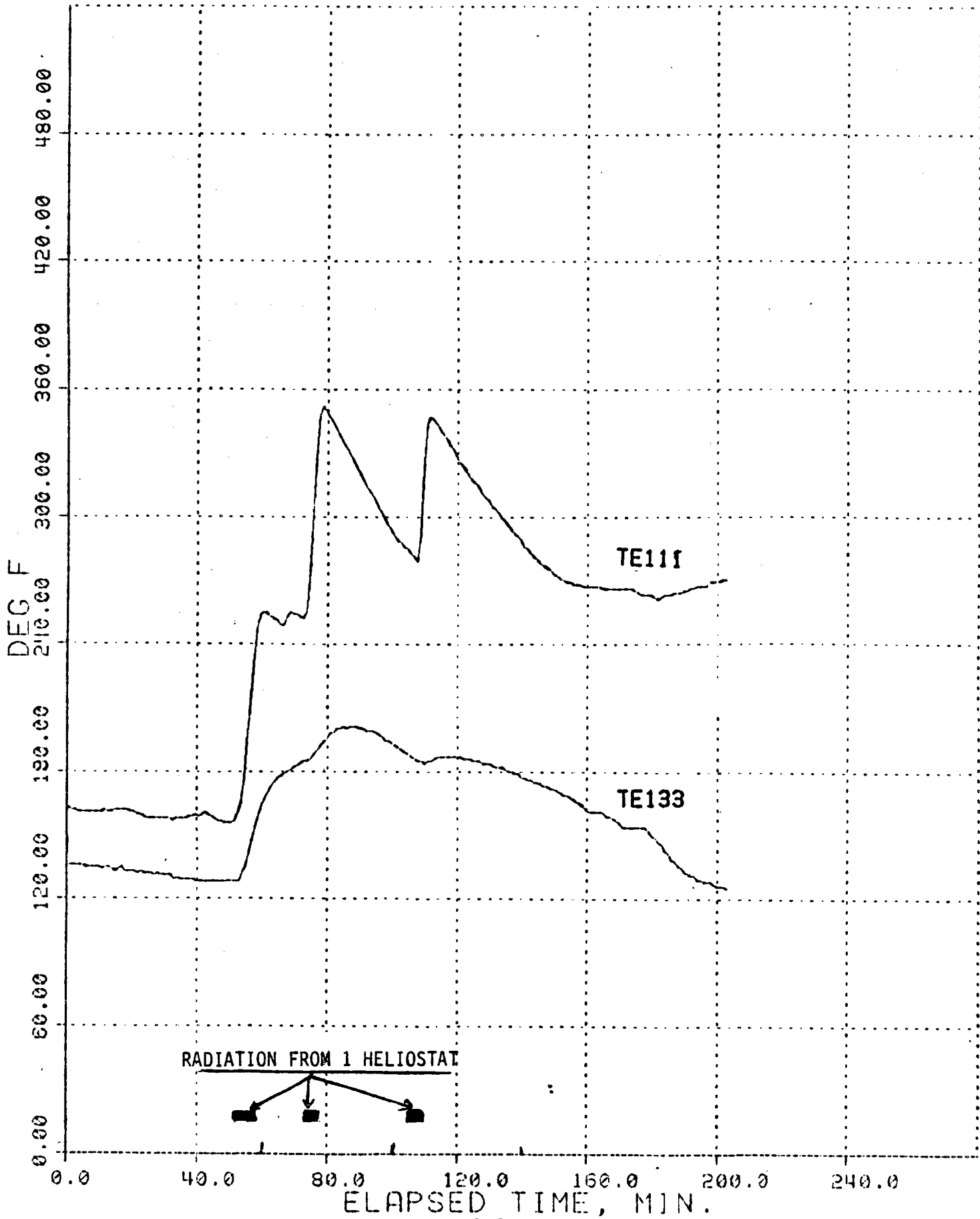

Figure 10

# RECEIVER THERMOCOUPLE LOCATIONS

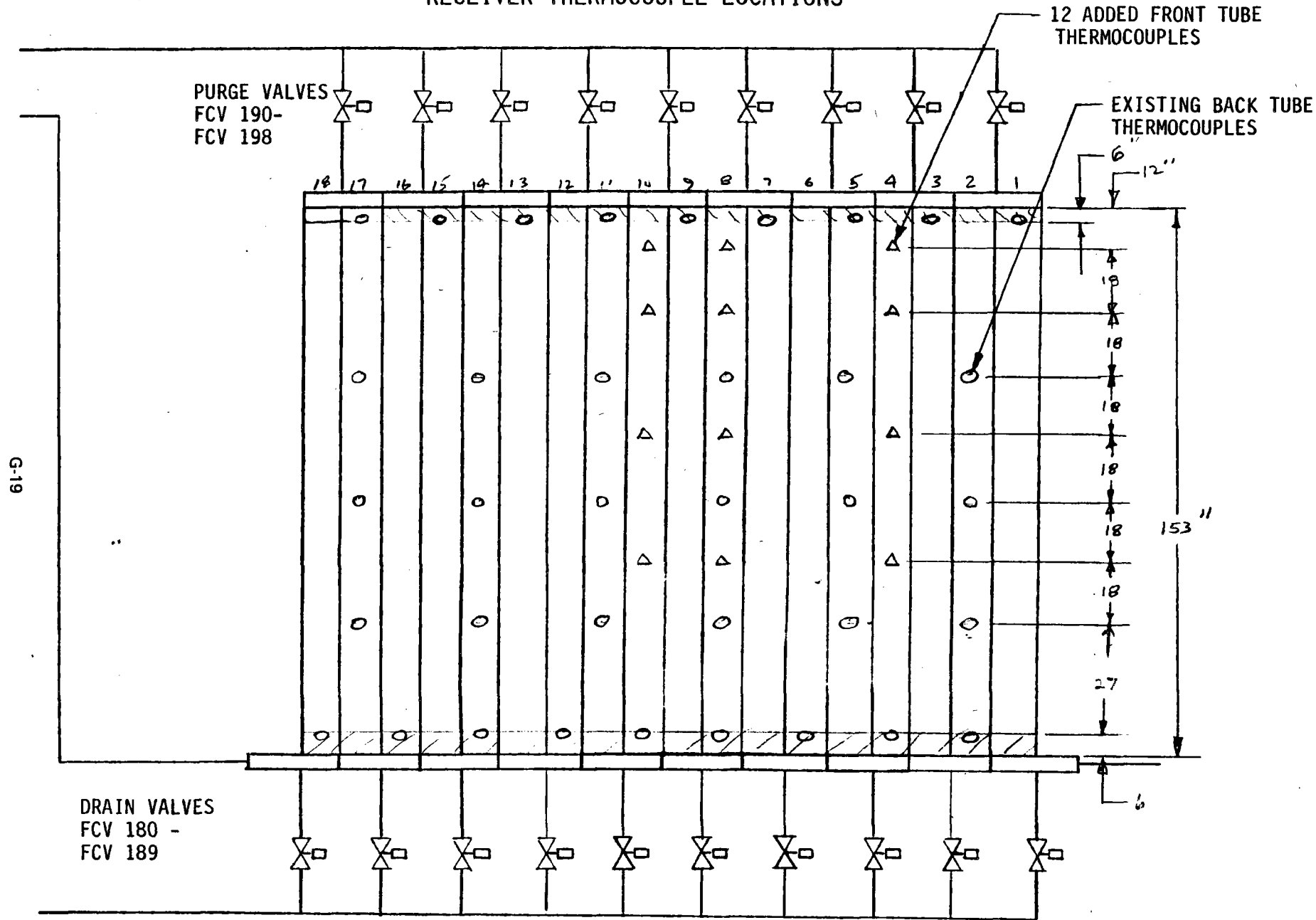

Figure 11

# RECEIVER THAW

PASS 8 VERTICAL TEMPERATURE PROFILE

9:00 - 9:45

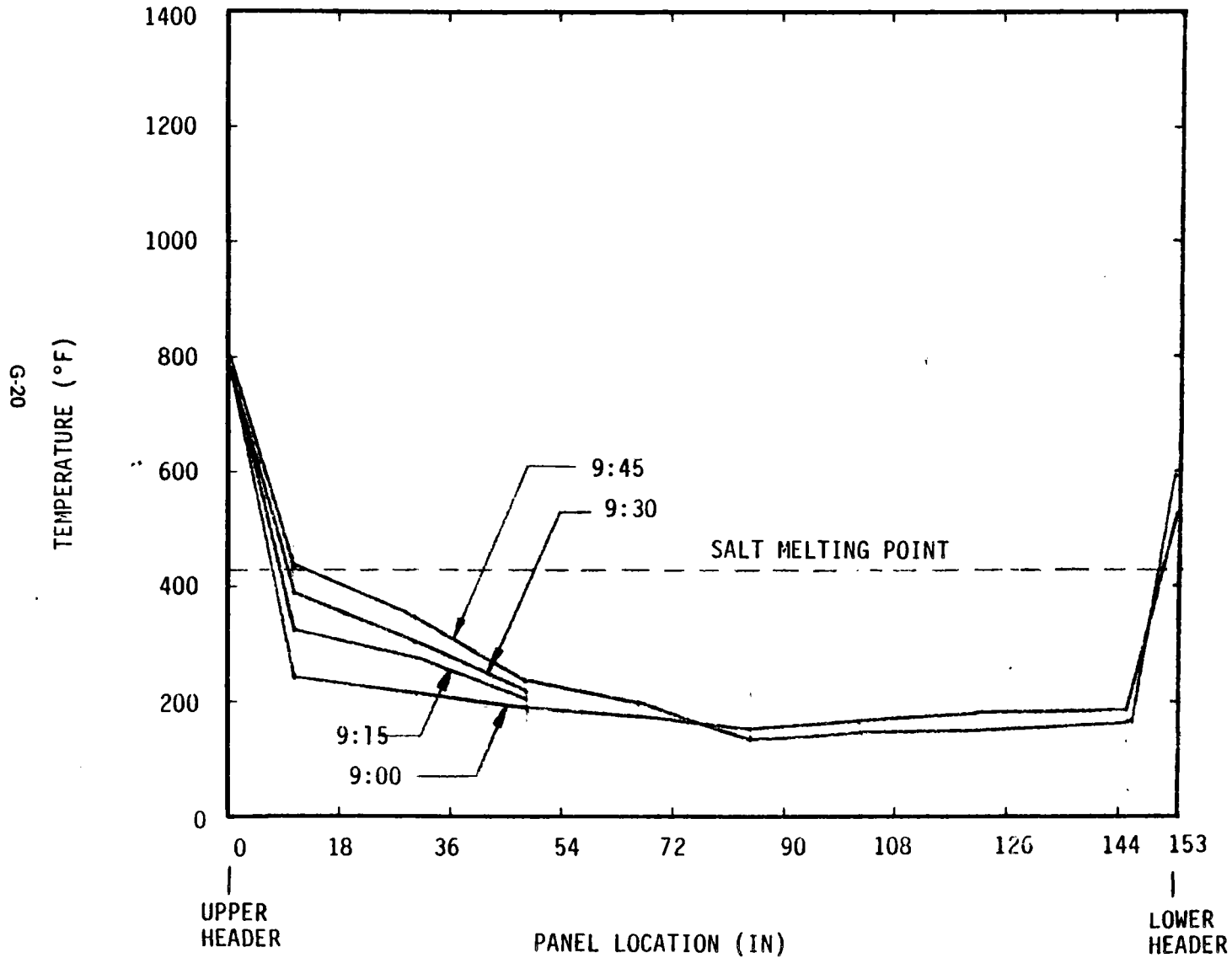

Figure 12

# RECEIVER THAW

PASS 8 VERTICAL TEMPERATURE PROFILE

10:00 - 10:45

G-21

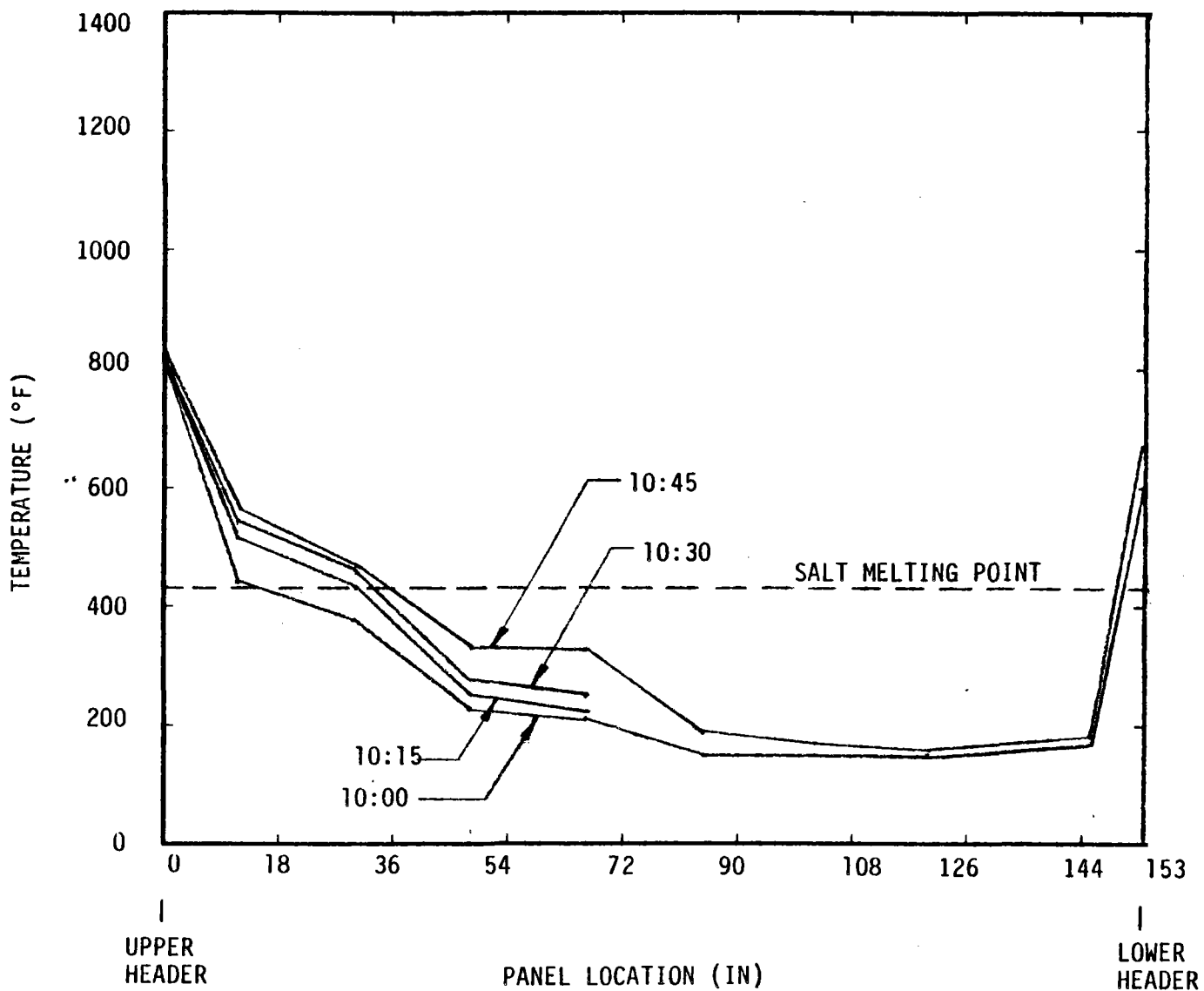

Figure 13

# RECEIVER THAW

PASS 8 VERTICAL TEMPERATURE PROFILE

11:00 - 11:45

G-22

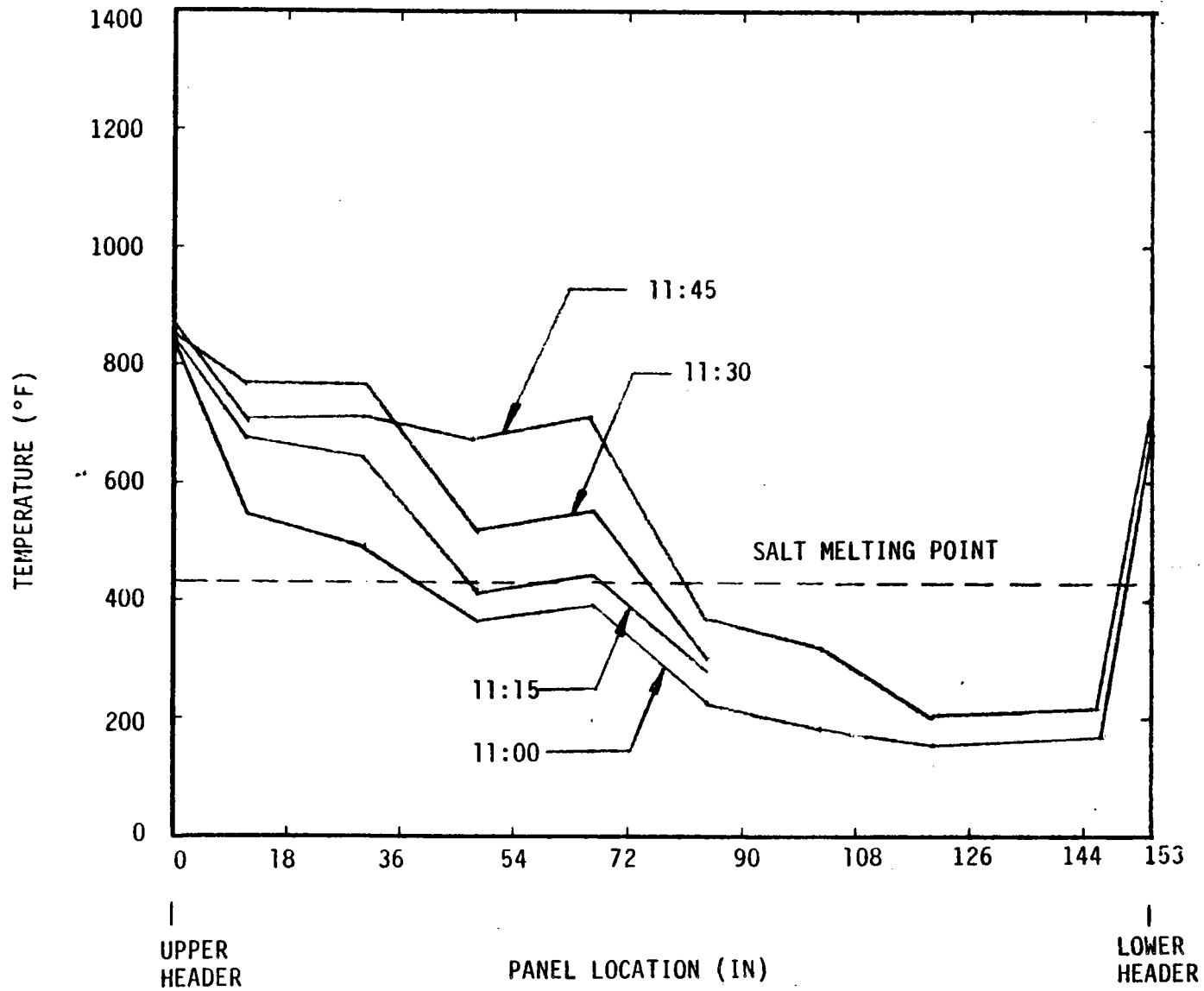
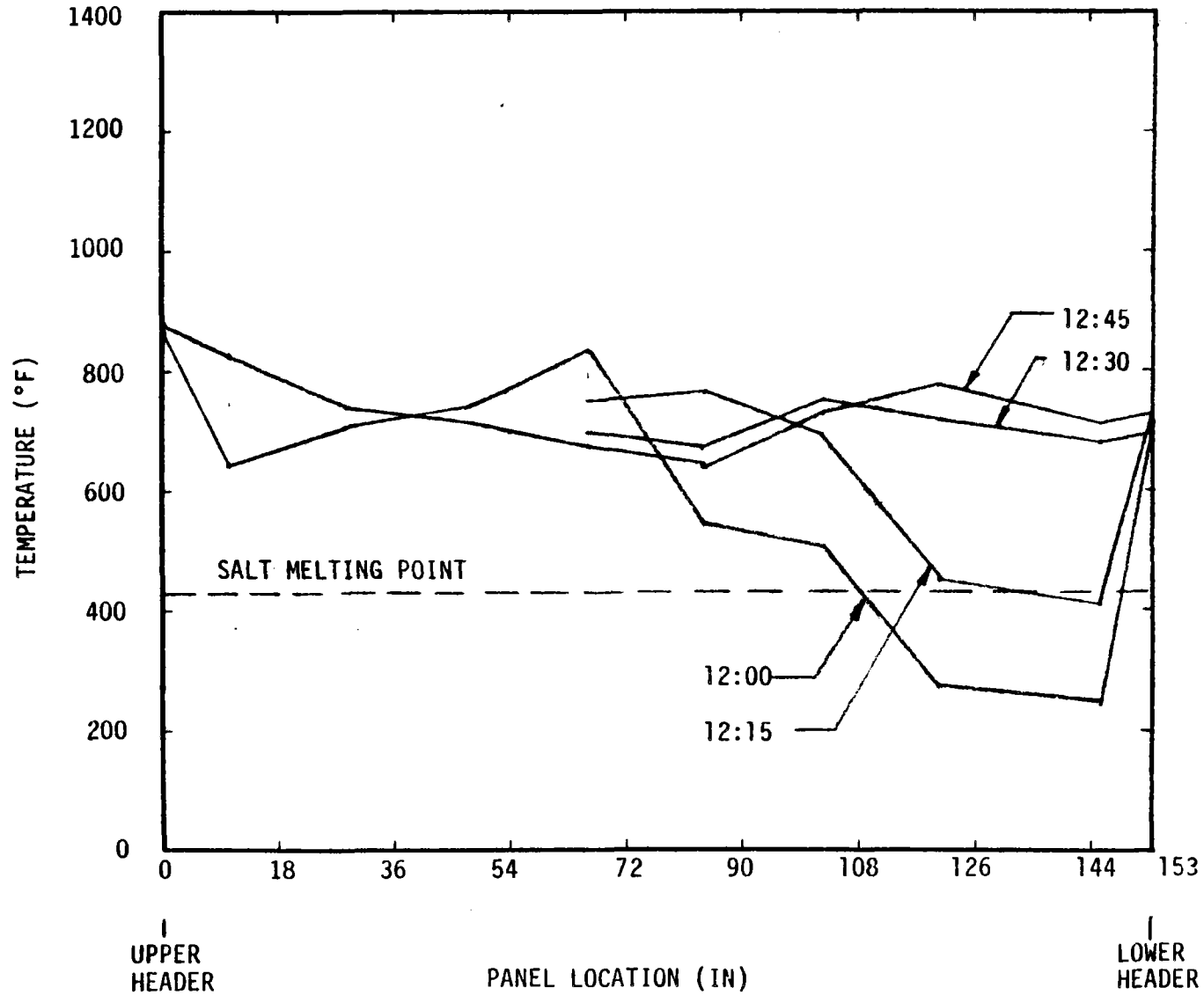

Figure 14

# RECEIVER THAW

PASS 8 VERTICAL TEMPERATURE PROFILE

12:00 - 12:45



G-23

Figure 15



ADDENDUM H  
TURBINE-GENERATOR FAILURE

# Sandia National Laboratories

Albuquerque, New Mexico 87185

date: June 20, 1985

to: Distribution



from: L. Nelson

subject: MSEE T-G Damage Report

During the week of April 1-5, 1985, certain events occurred that resulted in damage to the turbine shaft driven (geared) oil pump, turbine bearings, and possibly other components as of yet undetermined. This report discusses those events and the damages thus sustained. I apologize for the delinquency of this report, which can be attributed to the subsequent demands of the Power Production Campaign.

Summarized for point of reference, I present these applicable line listings from the T-G operating history document:

----- (4/1-15/85) Operation planned to optimize system performance prior to MSEE Phase III--Power Production Campaign

Tue 4/2/85            Local Training Operation  
                      --Egan/Holton/Griego  
                      --Extreme Load Instability  
                      --OST  
                      --Governor Operation Static Review

Wed 4/3/85            Governor Check-Out Operation  
                      --Roll-out Low Oil Pressure Trips  
                      --Found Failure of Shaft Driven Oil Pump

Thu 4/4/85            Gear Housing Breakdown and Review  
Fri 4/5/85            --Oil Pump Removed  
                      --Driven Gear Hub Broken, Shaft Bent,  
                          Bearings Seized  
                      --Water in the Oil  
                      --Turbine Bearings Scored  
                      --Overall Failure Cause Indeterminant

## Operation

Tuesday, April 2, 1985; The first day of system 'practice' operation. All operators started work at 6:00 a.m. I operated the control console for RS/HRFS/SGS start-up, and then transferred console operations to Lindsey Evans in order to relocate to the T-G area to oversee local operations. At the T-G area I found Jay Holton/SNLA, Jim Egan/Bechtel, and Jerome Griego/SNLA contractor. They were proceeding through

the EPGS pre-test checklist very thoroughly since Jim Egan was training to assume local operation of the T-G during the later power production campaign. Jerome was refreshing himself on current T-G operation and I was answering questions as they arose. The roll-out went slowly and smoothly with Jerome initially operating the throttle valve hand wheel and Jim completing the procedure to bring the turbine up to full speed. Two test trips were conducted--an 'overspeed trip' and an 'emergency trip', both at half speed. Nothing unusual had occurred to this point--the roll-out was exceptionally slow and deliberate corresponding to the learning in progress. It was decided not to conduct the third, full speed test trip due to this long roll-out, system demands, and the questionable benefit of so many trips. Upon attaining full speed, Jay Holton initiated generator voltage build-up and Jim Egan prepared to synchronize under my direction. Just prior to synchronization, the synchroscope meter speeded up its rotation and discouraged our first attempt. This was stranger than usual, but I did not feel it was abnormal because of the past poor performance of the Crompton synchroscope, wherein it would routinely speed up and slow down slightly as its needle rotated. Jim synchronized the next time around and added the normal load--governor switch held to increase for three seconds. Control was achieved and loads stabilized. After a ten minute heat soak, again foreshortened due to the long roll-out and system demands, Jerome attempted to add load and instability occurred at about 100KW. I advised Jerome to reduce load to restabilize, which he attempted without success. This had usually been successful during instability that had occurred during numerous past operations.

At this point I assumed control and attempted to add load, with the idea that a change in load had been successful before. This was also without result, but I continued to attempt restabilizing, since success had been achieved in the past under similarly unstable conditions. Today, however, the instability got worse. Weighing safety against opportunity, I continued restabilizing attempts while pondering means to isolate the problem. This led to a consideration that the synchronizing motor/control might be malfunctioning. With this in mind, I moved to the turbine and attempted changing load with the manual control knob. This also did not help and a short time later the T-G tripped on overspeed. We were on-line 26 minutes total. Proposals for further check-out operation were discouraged and we shut down to review the operations and equipment.

There are three things I would like to point out at this time. At no time did I feel that the operation was totally out of control or I would have manually tripped off the T-G. Secondly, the instability was in load control and not the voltage control. This fact obliterates the static exciter fom fault and was verified during past instability occurrences. Thirdly, all operators involved acted responsibly and without fault, except perhaps on my part for not shutting down sooner. All operating procedures had been correctly followed.

That afternoon I called G.E. again regarding the instability, but as usual, could not reach any answerable personnel. I did seriously discuss the problems with other responsible NMSEE parties and heavily attempted to impress upon them the seriousness of the problems. Additionally, Chuck Lopez/SCE Solar One, who was here as part of the data evaluation team this week, heard of the problems and became interested in them. Staying late, we reviewed the drawings, the operating circumstances, and the actual equipment. I did find the 32x aux. relay energized, which was peculiar, and all the more so since I couldn't effectively deenergize it. This relay automatically recloses the throttle valve after a gen. breaker trip. Turning off CBP power, including the UPS, did reset it. Further review found little else except more possible mechanical problem sources, but I gained a much better understanding of the governor systems operation through Chucks help. Slight looseness in the linkages tightened up upon application of oil pressure. Synch. controls worked properly.

Wednesday, April 3, 1985; Early morning operation was scheduled for sunrise start-up practice and further T-G checkout. I again operated the control console for RS/HRFS/SGS startup and then relocated to the T-G area for local operations there joining Jay Holton and Earl Williams/PNM. During initial roll-out, a couple of trips were experienced which were soon traced to a low oil pressure interlock closing the steam stop valve FCV-501. The control room had no indication of the source of this trip since it is hardwired. I presumed its cause was misaligned HV-520, used to balance bearing oil pressure against hydraulic control oil pressure, since this had happened before. We tried again after readjusting HV-520 and also started suspecting the EOP cutout circuit. Another trip occurred. Preparing for another attempt, Jay particularly watched the EOP and I watched the local bearing oil/hydraulic oil pressure gauges by HV-520. This time we found, with continuous EOP operation, that oil pressures decreased with faster turbine speed. Turbine speed was taken well above the point where shaft driven oil pump pressure should have occurred. I knew then that a failure of the shaft driven oil pump had occurred, since that was the only thing left at that point. This information was radioed to the control room. When asked how this could be verified, we shut off the EOP momentarily with the turbine at about 1/2 speed and watched the oil pressure gauges drop to nothing. The EOP was immediately restarted to protect the bearings. We then shut down and secured the rest of the system.

Before we left the area, we opened the shaft oil pump inspection plate on the turbine reduction gear housing. Inspection revealed that the oil pump driven gear had broken at its hub and had fallen down upon another gear. This gear had worn down some of the driven gear teeth.

A post-test meeting was called and these occurrences and findings were discussed. The remainder of the afternoon was spent starting the search for replacement parts.

## Inspection

Thursday and Friday, April 4 & 5, 1985; Turbine oil pump removal and review scheduled. The upper casing of the reduction gear/oil casing was lifted free to remove the shaft oil pump. To lift this upper casing, governor/throttle valve linkages & T/C's were disconnected and the turbine thrust bearing disassembled. Reference was made to the T-G O&M manual during the course of this work. It should be pointed out that it will be necessary to have manufacturers present to reassemble & realign the thrust bearing.

After disassembly and lifting off the upper gear casing, the shaft driven oil pump was removed and relocated to a bench area for further breakdown and review. It was found that the oil pump had its bronze driven gear hub broken and a portion of three of its teeth worn down, its shaft was twisted - apparent from the keyway and its sleeve bearings or bushings were seized. This can be clearly seen in the photographs attached. It is also important to realize that the upper portion of this gear pump assembly drives the governor (fly weight) mechanism. This makes it impossible to operate the T-G without this assembly. The oil pump itself cannot just be replaced with an external oil pump.

Further inspection of the turbine gear housing that was open revealed a possible scoring of the turbine inboard bearing. The on-site technicians all felt that these had been damaged, but reviews by others have not confirmed this beyond doubt at this time. Small pieces of what appeared to be silicone gasket material were found on the bearings. The turbine outboard bearing was then opened and inspected with similar findings.

Oil in the reservoir was also noted to be bad and was subsequently drained thru a seive and the reservoir cleaned. There were no pieces or filings of metal found during this process, but a great deal of sludge and water was contained in the oil. A sample from this seive filter was retained. The amount of sludge/water in the oil was approximated to be 10 gallons. Oil contained in the reservoir is approximately 62 gallons. The oil cooler, suspected as a source of this water, was also subsequently hydrostatically pressure tested and found to be intact.

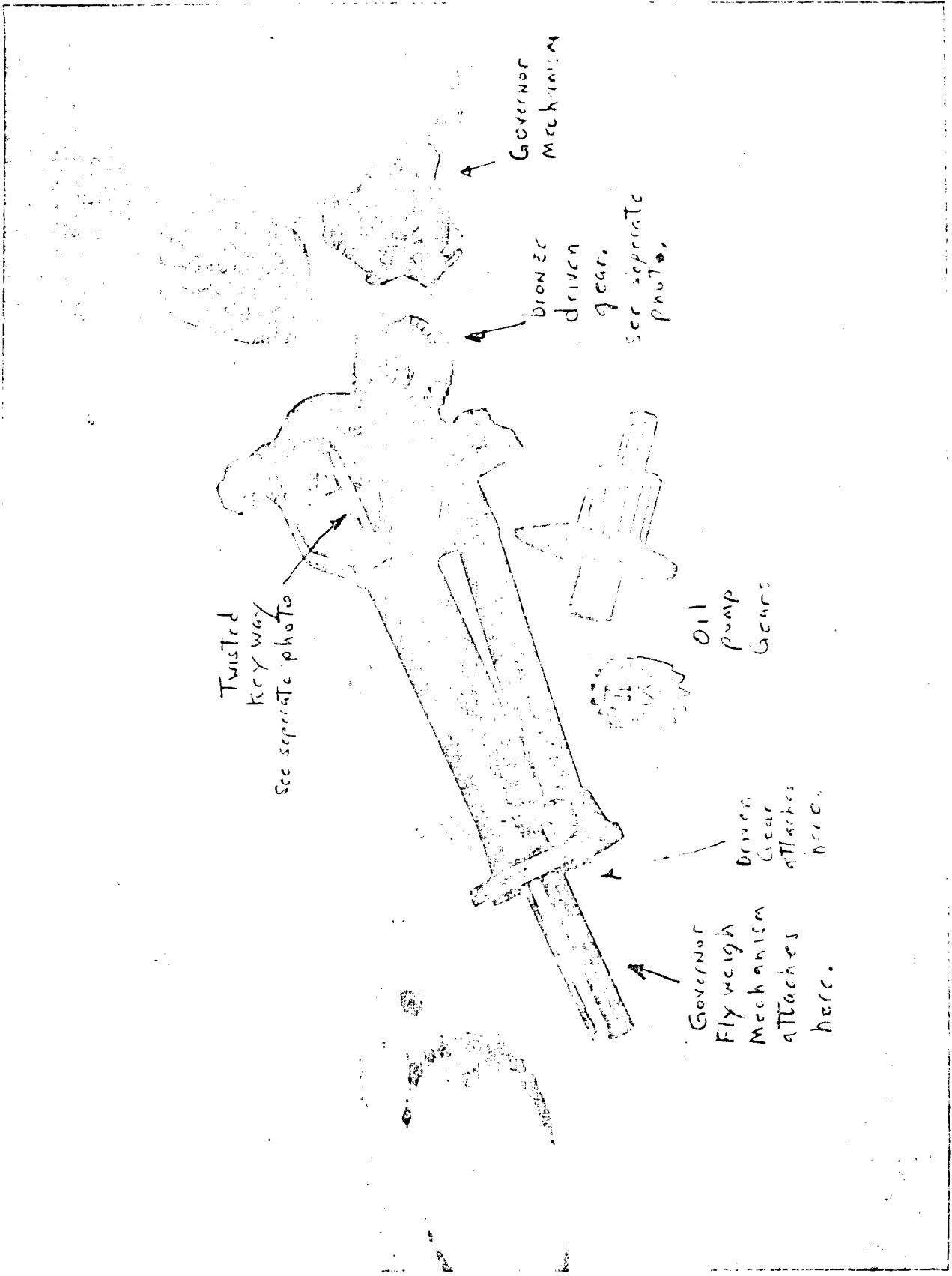

Oil Pump Assembly

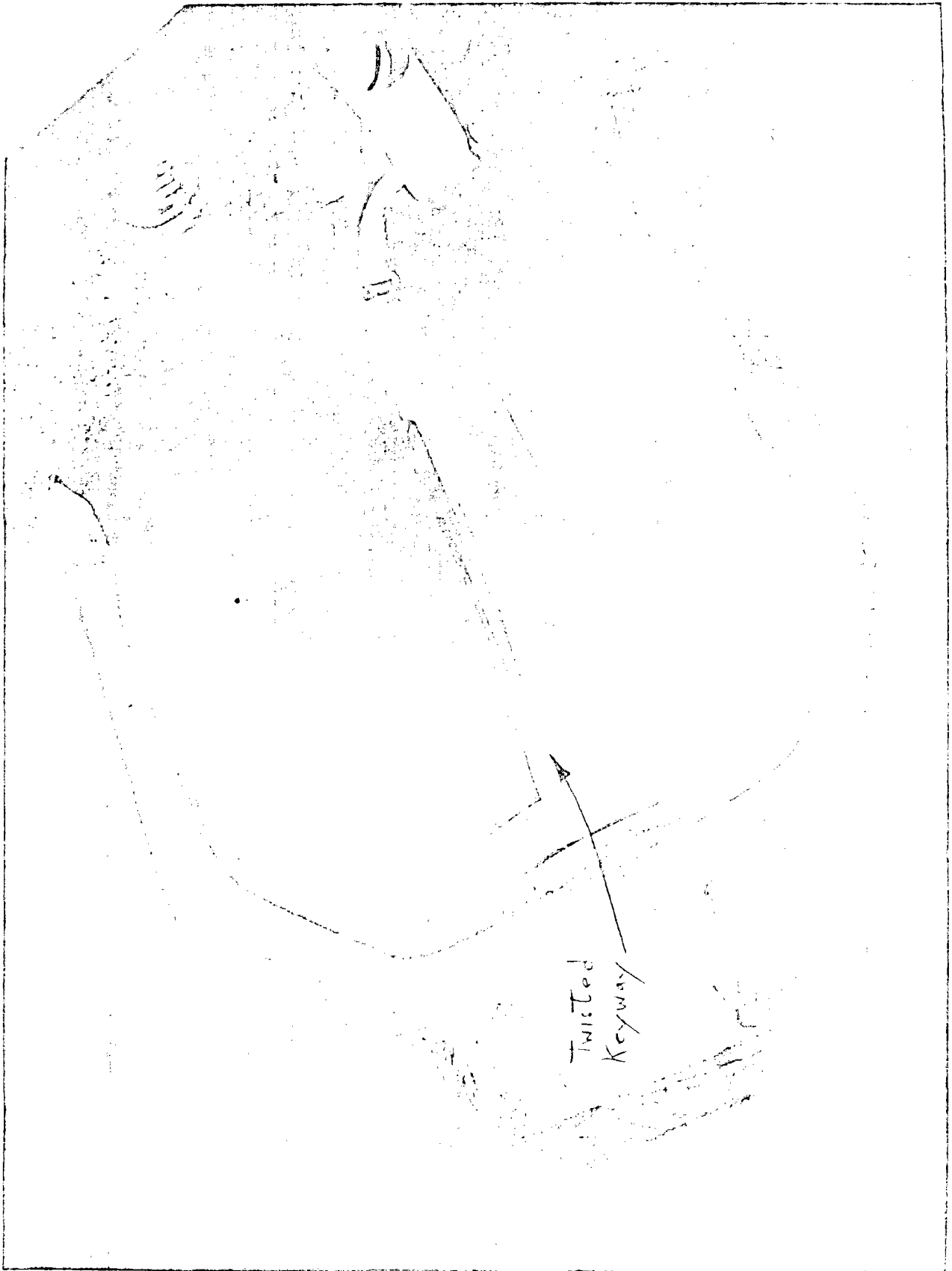

Oil Pump Twisted Shaft

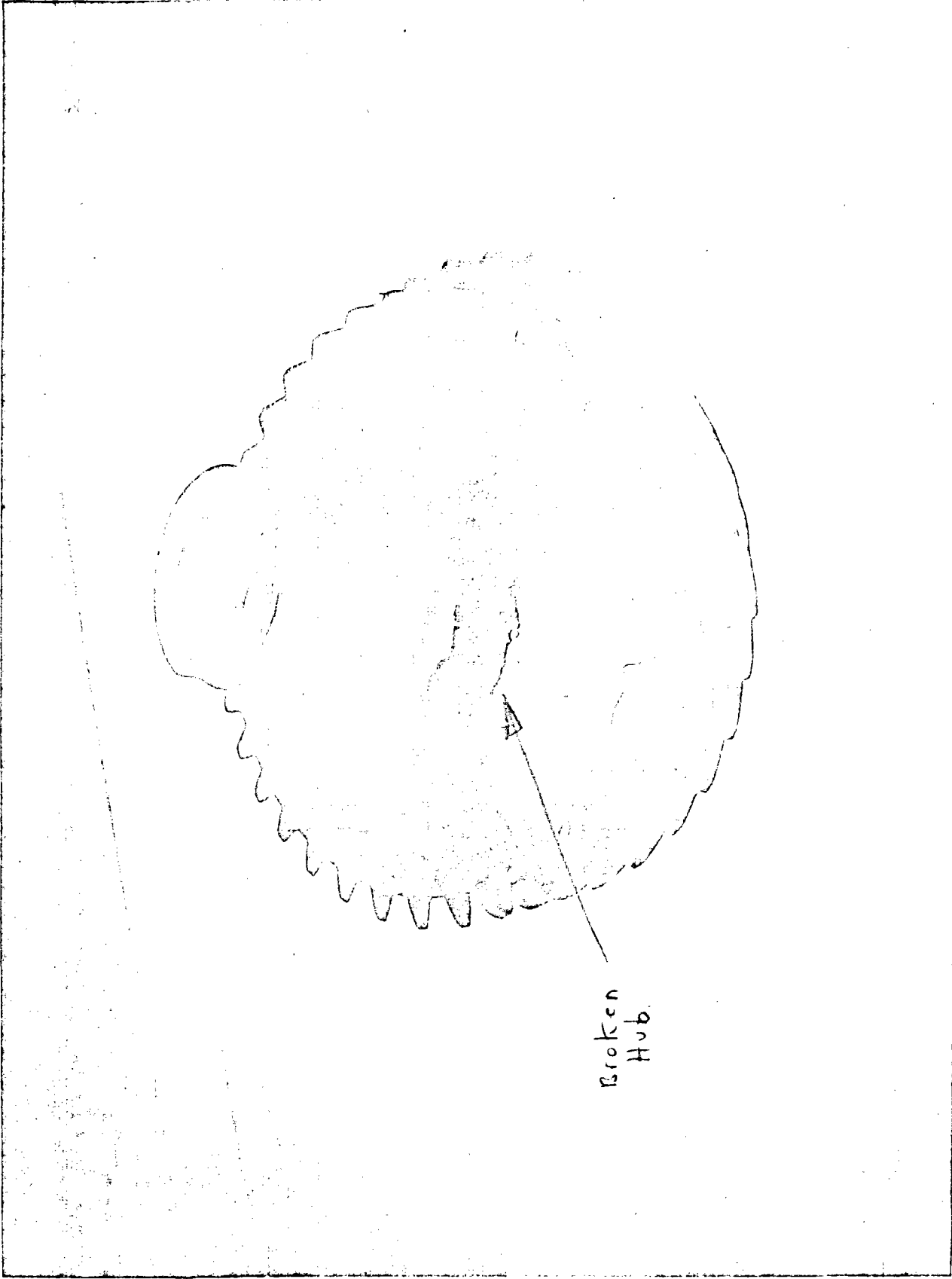

Bronce Driven Gear of Oil Pump Assembly

Broken  
Hub.



## Analysis

The overall cause of the failures has not been positively determined at this time. With this in mind, it is necessary to relate other associated observations or knowledge which may be pertinent. These may help determine the actual cause or at least qualify some extreme speculations.

A source of the water in the oil must be found. Since it was not the oil cooler, another source might be process steam. It was previously known that the turbine inboard steam seal had a major leak from atmosphere to the vacuum system. This had been controlled by adjusting HV-586. This seal consists of 4 labyrinth seals and three interseal chambers. Attached Fig. 19 from the T-G O&M manual depicts this clearly. Since the outer chamber was known to leak and had its vacuum bleed severely restricted, the possibility of a further failure and resultant steam dump along this path would seem to be increased. This location also sees the highest pressure steam. A positive determination may be found by a review of these seals, which may require a disassembly of the turbine. Water accumulation in the oil through condensation is unbelievable and would probably have been noticeable on the oil dipstick.

The oil system always looked good during operation, with the exception of oil foaming. This had been occurring since day 1, and was reduced to where it did not foam out the OST mechanism by removing the fine mesh oil filters initially used for the oil flush. The oil on the dipstick looked good - clean, no water or sludge at all apparent, during all operating days - including Tue and Wed 4/2 & 3/85. This was everyone's opinion associated with the T-G & not just my own. Also, there was never any abnormal amount of vapor, oil or otherwise, rising from the oil reservoir vent. It seems likely that steam would have poured from this vent had the steam seals failed.

Load instability problems have never been resolved. After consultation with Basler & G.E. and direct observation, I do feel the instability is not originating in the voltage regulator. I have further readjusted the stability circuit potentiometer on the static exciter's voltage regulator to confirm this. I have always come back to the turbine governor as being the source of the instability. Load fluctuations, since we are on the end of the PNM/Kirtland/Sandia grid, might occur occasionally, but not create the instability we've seen. The instability is not at the same load always, either. However, a review of the integral governor system on the turbine quickly suggests a complex source of problems. See the attached Fig. 23 from the T-G O&M manual. Indeed, air or water in the oil may play a large part in this pilot valve/hydraulic cylinder control. Other ideas - loose linkages, sticky flyweights, small restrictions in the pilot valve, oil pressure fluctuation, etc. may be playing a part. This problem needs to be positively corrected, and just replacing the T-G itself may not even be the answer.

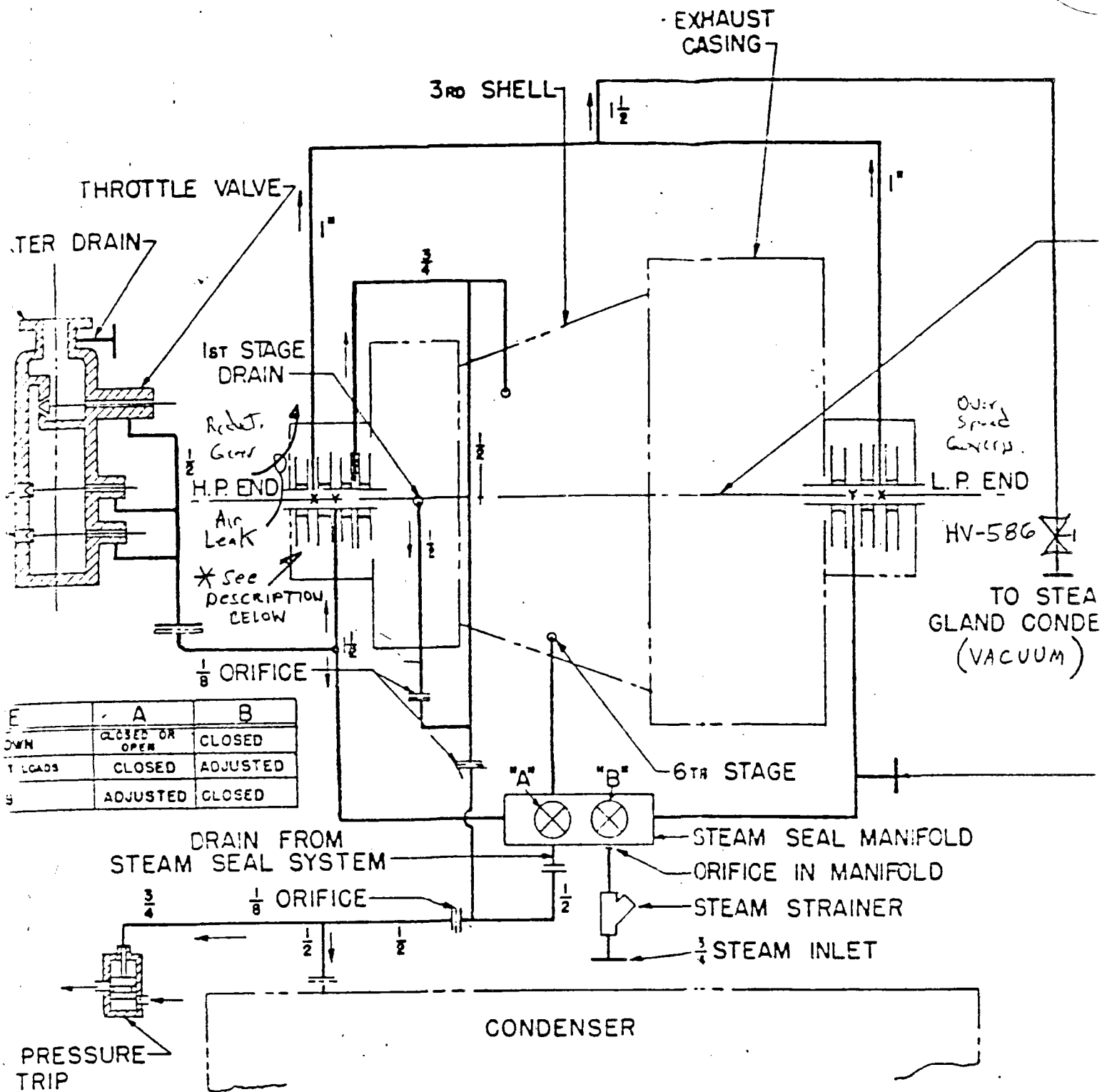

**\* Turbine Inboard Steam Seals**

The inside chamber collects steam chest leakage and dumps this to lower pressure stages. The middle chamber 'Y' is supplied with equalizing steam from the throttle valves. The outer chamber 'X' collects leakage which is bled off by the vacuum systems. Note: strictly L. Nelson's interpretation.

T-G  
of M  
MANUAL

Fig. 19  
Steam Seal  
& Drain Diagram

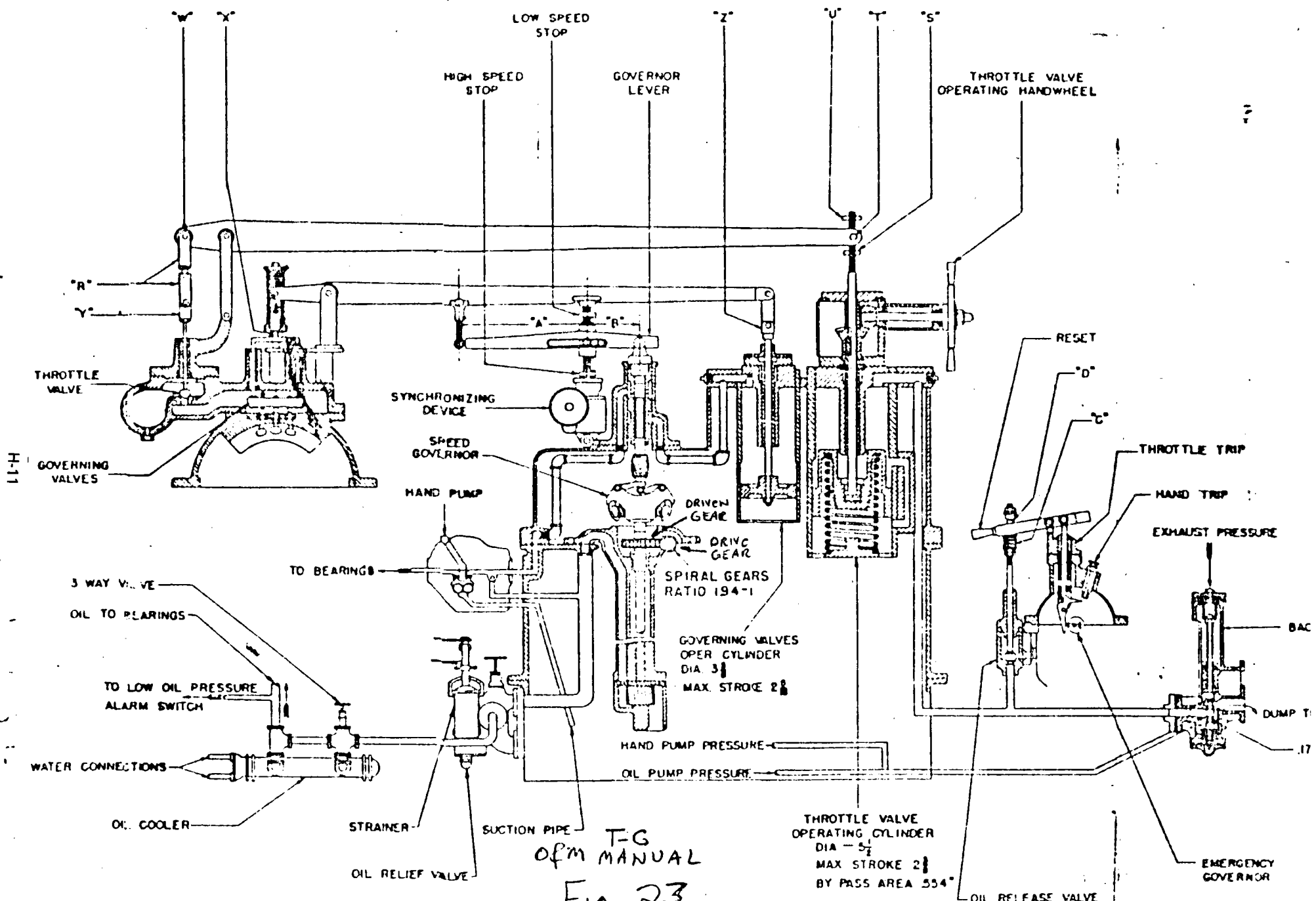

T-G  
 OFM MANUAL  
 Fig. 23  
 CONTROL MECHANISM  
 (T-9074424)

The oil pump failure is not fully understood either. This is somewhat related to the governor control, since it is on the same shaft, but is probably a separate problem due to the positive engagement gears. Water in the oil could have caused a loss of lubrication, wherein the bearings seized, twisted the shaft, and broke the driven gear at its hub. It seems unusual that the sleeve bearings could have locked up that suddenly. Material in the pumped oil could have gotten in the gear pump teeth, but then the shaft might have twisted differently or destroyed the pumping gears. Nothing was found in the oil to support this, but it could have been destroyed or have been a cavitation vapor-lock. Perhaps metal fatigue played a role since this turbine is 33 years old.

Turbine bearing problems and possibly reduction gear pitting can probably be traceable to poor oil quality.

#### Summary

T-G damage was not caused by operator error. The actual cause has not been fully determined. A breakdown of the T-G may help in this determination, but the decision to restore the EPGS to operational status will have to be made first.

LWN:6222:nsf

Distributed under MSEE T-G status letter

# Sandia National Laboratories

Albuquerque, New Mexico 87185

date: June 20, 1985  
(Updated from Feb. 27, 1984)  
to: Distribution

  
from: L. Nelson

subject: T-G Operating History to Date

Chronological order is correct, but not all dates are exact.

## I. Start-Up Period

8/12/83	T-G Alignment - Fred Warren/G.E. rep from Argo Marine on-site
9/2/83	Steam Blows - Rich Crain/PNM oversaw
9/17/83	Relaying & metering calibration - L. Nelson coordinated PNM assistance
9/23/83	Turbine oil installed
10/2/83	Electrical oil pump piping revised
10/6-22/83	Turbine oil flush - Rich Crain/L. Nelson conducted
- - -	(10/10-11/28/83) BCP Repair, SGS salt tests
12/5/83	Gen. backfeed, New 4.16kv xfmr's energized - L. Nelson oversaw
12/7/83	Turbine roll for steam cleaning - 1:00 pm Wed. - Rich Crain/PNM, L. Nelson oversaw - Full speed oper. attained - 1200 Gen RPM - Oil filters extremely dirty, oil foaming excessive - Steam seal system not functional - Gen. voltage not obtained - no residual magnetism - Minor instrument and misc. corrections.
12/9/83	Turbine oil changed

II. Electrical Problems Period  
[Excitation Problems]

- 12/12/83 Gen. start-up attempt
- Turb. oper - oil filters remained clean
  - Amplidyne exciter flashed per Basler instruct.
  - Gen brush sparking with reverse pwr. trip
  - Shutdown to review problems
    - recheck brush taper and tension
    - reverse power relay install. and oper.
    - Voltage regulator integrity
  - R. Crain /PNM notes oil looks fine even though foaming is excessive
- - - (12/12-23/83) FWP cavitation reviewed, FCV-401 trim repair
- 1/3/84 Chevron contacted regarding oil foaming, Anti-foaming agent discarded
- 1/6/84 Gen. S/U attempt (PNM assisted)
- Turb. operation
  - Rev. pwr tripping kept turb. from full speed, 32 relay disabled since it should not be operating with ckt bkr open.
  - Smoked parallel. module sensing Xfmr as turb. came up to full speed.
  - Shutdown manually to review and correct problems; including determining why small xfmr smoked, why rev. pwr trips occurred.
  - With PNM assist, we found sensing xfmr tap conn's wrong and rev. pwr relay trips due to high intrinsic impedance of series C.T. ckt. (sensitivity of relay decreased by PNM to correct tripping). I reck'd (ok). The gen was disconnected and gen line backfed to ck install. - A jumper was added for all-phase voltmeter sensing, All conn's ck'd ok.
- 1/12/84 Gen S/U attempt (PNM assisted)
- Turb. operation, fine mesh oil filter removal corrected oil foaming problem, steam seals still not working. (G. E. stated steam seal not mandatory for operation) - Chris Eastman 1/9/84 2 lbs steam normal oper.
  - No smoke or rev. pwr trips

1/12/84 (cont'd)

- Overvoltage experienced with exciter disconn. (600 + volts at full speed - meter only goes to 600V)
- Under PNM recommend - Deguassing was attempted without success by reverse manual excitation with turb. at 1/2 speed and by reverse flashing.
- Overvolt (G.F.) relay trip occurred once, probably due to O.V.; relay reset and attempts cont'd
- All conceivable attempts to correct problem failed, shutdown at 6:30 pm due to lateness and to review problem.

- - - (1/18-3/15/85) Circ. heater vessel failure & replacement

1/20-3/3/84 Exciter replacement

3/20/84 Exciter Check-out oper.  
- 4.16 kv deenergized  
- Condenser flushed  
- Oil heater oper. automated  
- Procedure and P & ID updates

4/2-4/84 T-G Check-out oper.  
- Gen. volt would not build-up  
- Problems isolated to new exciter  
- Instr. corrections  
- Basler rep. assists correction of Power Isol. xfmr connections

[Phasing Problems]

4/5,6/84 T-G Check-out oper.  
- Howard Coleman observes  
- Don Tidwell & Elwin Johnson/PNM assist  
- Synch attempted many times - rev. pwr. trips  
- Gen. winding problems considered

4/12/84 Gen. Check-out oper. on resistive load bank  
- Gen. waveform ripple traced to measurement  
- Sandia vibration review found 1 mil displacement (low vibration)

4/13/84 First Synch  
- Metering & Relaying disconnected, ck-out restarted

4/18/84 Phase problem found and corrected (Elwin Johnson/PNM)  
- Cab. and Bus phasing were reversed  
- LT-311 repiped, FCV-471 plug replaced

### III Operating Refinement Period

4/27/84 Synchronized operation  
- Steam seals don't work  
- Instrument corrections

5/9/84 Local oper. with full system  
- Volt. regul. auto oper. proven

5/11/84 Remote oper.  
- J. Holmes synch.'d from control room  
- Emerg. trip oil restriction found

5/21/84 Overall operation verified  
- MMC EPITP's completed

5/22/84 Corrective maintenance  
- Steam seal vacuum leak found, GE contacted  
- Oil pipe trip restriction cleared  
- Steam & oil strainers cleaned  
- BPT device calibration & operation checked  
- Spare parts reviewed

- - - (6/6-20/84) FWP seal replacement, RS panel salt freeze & thaw

6/26/84 Rated output achieved - 750 kw  
- Vacuum leak corrected by closing HV-586  
- Gen. air temp. trip at rated load - stability maintained  
- FCV-501 steam leak, condenser flushed

7/17/84 PNM Support Oper. (Now through 5/19/85)  
- Fire dept. call-out due to steam drain blowdown  
- 5 trips, most due to steam drum level excursions  
- Roll-out procedure corrected

7/31/84 5 MWH's generated  
Phase I testing completed  
- Steam traps replaced  
- Single point pump control implemented



IV Utility Training Period

- - - (8/5-17/84) Trial Team Training & Oper.
- 8/15/84 T-G Demon. Oper.  
- Oper. control error created instability  
- Remote Roll-out unacceptable
- - - (9/2-20/84) PNM Team Training & Oper.  
MSEE dedication
- 9/17/84 T-G Demon. Oper.  
- Short shutdown to return condensate  
- Turbine exhaust temp. monitor added  
- EOP automation completed  
- Condensate storage tank make-up automated
- 9/18/84 Generation Record - 3 1/2 hours continuous at 500 kw  
- voltage regulator stability adjusted  
- load instability
- - - (9/23-10/11/84) APS Team Training & Oper.
- 18/8,10/84 T-G Local & remote oper. demonstrated  
- Load instability near 200 kw
- 10/11/84 Turbine oil changed
- - - (10/14-11/1/84) PG&E Team Training & Oper.
- 10/25,28,29/84 T-G Local Oper.  
- Load controls stable  
- Daily continuous Gen. record - 3 1/2 hrs, 1392 kwh
- 10/30/84 Overspeed Trip (OST) Tests conducted with PNM operators  
- OST speed approx 1285 Gen. RPM  
- load instability randomly occurred, Basler contacted  
- Steam seal oper. relative to backpressure clarified  
- Desuper FCV-432 leakage limited elect gener, 5WHX isolation permitted 920 kw peak generation  
- EOP auto start PS setpoint adjusted

11/1-5/84 T-G Maintenance  
- Vibration & Hydraulic oil press trip corrections  
- Gov. linkages greased  
- Load instability discussed with Jack Rex/PNM  
- Oper. proced updating on-going

- - - (11/4-15/84) Mixed Team 1 Training & Oper.

11/13-15/84 T-G Demon. Oper.  
- Portable Radio Trip  
- Instability  
- Roll-out proced further modified

- - - (11/25-12/5/84) Mixed team 2 training & Oper. Cancelled prematurely due to FWP failure

- - - (12/4-31/84) FWP Failure, repair started. Phase II completed

- - - (1/1-3/8/85) Phase III reliability improvements  
- RS trace heat replacement  
- CT - CS pipeline replacement  
- FWP/BP repair

2/8/85 Turbine Oil changed, Oil strainers cleaned

- - - (3/12-29/85) B. P. Failure & Repair Power Production Campaign delay to 4/15

3/25/85 T-G Integrity Operation via Propane Heater

V. Mechanical Problems Period

- - - (4/1-15/85) Oper. planned to optimize system perform prior to MSEE Phase III Power Production Campaign.
- 4/2/85 Local Training Operation  
- Egan/Holton/Griego  
- Extreme load instability  
- OST  
- Governor Oper. reviewed w/Chuck Lopez
- 4/3/85 Governor Ck-out Operation  
- Rollout lo oil press trips (via FCV-501)  
- Found failure of shaft driven (geared) oil pump
- 4/4/85 Gear Housing Breakdown and Review  
- Oil Pump Removed  
- Driven Gear Hub broken, shaft bent, bearing seized  
- Water in the oil  
- Total failure cause immediately indeterminent  
- Also found turbine bearing scored
- 4/8/85 Remaining MSEE operation planned without T-G
- - - (4/15-5/11/85) Power Production Campaign
- 6/12/85 Refurbishment of EPGs desirable for Cat. B  
- continue repair attempts  
- replacement options considered  
- Actual decision to return EPGs to service pending
- - - (Presently scheduled) MSEE refurbishment for Cat. B

LWN:6222:nsf

Distributed under MSEE T-G status letter.

6/20/85

T-G CORRECTIVE ACTION LIST  
(NOT PRIORITIZED)

Mechanical Corrections Required

1. Correct turbine shaft driven oil pump--driven bull gear hub broken, shaft bent, bearings seized. Note correction is required for integral governor control mechanism.
2. Determine the cause of this failure for correction, as possible - Ref. T-G damage report.
3. Determine origin of water in oil reservoir for correction. Clean oil system and refill with new, clean oil (61 gal.)
4. Correct turbine inboard steam seal leakage--remove turbine upper casing and probably turbine rotor, determine problem, procure parts, reassemble
5. Determine extent and correct scored bearings. Note: due to past journal grinding, standard spare bearings are not suitable
6. Review hi and lo speed gear tooth damage for corrections
7. Determine cause and correct load instability
8. Under manufacturer's direction:
  - Break down remaining parts of turbine/gear box and inspect for damage, correcting as required
  - Reassemble
  - Realign

(Manufacturer's direction mandatory now just to reassemble thrust bearing.)

Mechanical Corrections Recommended

1. Determine reasonable heat soak time for cyclic operation/procedures
2. Add oil/water separator (centrifuge)
3. Add oil/air separator
4. Provide auxiliary steam for initial steam seal operation
5. Replace BPT (Back Pressure Trip) Device adjustment mechanism to bring adjustment within tolerance

### Control Corrections Recommended

1. Add power factor set point follower (Basler)
2. Correct power factor PFT-581's insensitivity
3. Correct synchrosopes for smooth action
4. Add turbine steam FT-501: Relocate PT-582 sensor to turbine first stage pressure tap, recalibrate and relabel as required; flow is directly proportional to this pressure.
5. Correct steam seal PT-582's range of operation. Procure new instrument as required if existing PT is used for FT-501.
6. Modify EPS low enthalpy T-G trip TR-588 for roll-out operation.
7. Add analog electrical meters in control room for analog observation of generator electrical parameters
8. Add EPS2 reset switch at Turbine Control Panel.
9. Add GSTAT local control--such as from present hardware switches on back of PCM's (PCM-3)
10. Redesign TR-584 to trip from the hottest bearing instead of the coldest bearing (turbine inboard not generator outboard)
11. Revise controls to ensure FCV-501 locks in upon trips.
12. Desensitize vibration sensor AZT-581 portable radio trip
13. Install local RPM indicator observable from throttle valve
14. Consider tripping the turbine on high steam exhaust temperatures. PNM does, their operators tell me. Add local control panel monitor.
15. Consider adding turbine casing temperature monitors. This would tell-tale if our roll-outs and heat soaks are acceptable.
16. Add Governor and Voltage control position indicators.

## O & M Corrections Recommended

1. Update T-G trip list
2. Update EPGS operating procedures:
  - a. increase heat soak time based on thermal stress knowledge
  - b. include steam seal HV-576 operation
  - c. clarify lo enthalpy start up
  - d. update condensate makeup control--FY-472/FCV-471 SP's
  - e. delete CNST level adjustment from POP#1A, EPGS pre-test operating procedure
  - f. clarify GSTAT deactivation in POP#3, EPGS shutdown operating procedure
  - g. simplify EPGS pretest for periods of consecutive routine operation
  - h. Decrease use of test trips required during S/U for:
    1. Consecutive routine operation
    2. Knowledgeable people
    3. Confidence in operation
    4. Reducing stress on equipment
3. Procure Spare parts for EPGS pumps (as required)  
Procure more turbine oil. T-G spare parts?
4. Organize display groups (Emcon or Net.90) for:
  - a. PCK, auto controls alignment prior to remote transfer
  - b. Monitoring operating parameters, such as bearing temps, cooling water temps, stator temps, hotwell level, etc.
5. Automate GSTAT deactivation for emergencies
6. Update 'PAL' operating alarms
7. Revise PT-583 Hi & Lo alarms for operating compatability
8. Obtain G.E. dwg K-1078421-83467-1 for T-G performance steam rates for various back pressures & initial conditions.
9. Inspect generator breaker integrity - Load contacts/arc shutes. Preventative maintenance item since it has been subjected to some unusual trip situations - Full load, OST's, protective relay trips.
10. Update electrical drawings with as-built information. The initial installation totally revised B&V's original design drawings. Present design sketches are extensive, but disorganized and slipshod.

## Personnel Recommendations

- I. Assign one person to oversee and be responsible for the EPGs. His conscientious responsibilities would include.
  1. Oversee proper T-G operation - operation by unskilled, unconcerned people is unsafe both to personnel and to equipment.
  2. Insure operating procedures are correct and up-to-date
  3. Insure preventative maintenance tasks are performed.
  4. Be a first source of T-G knowledge:
    - a. How it works
    - b. Why it works
    - c. File & update ref. material - manuals/dwgs.
    - d. Oversee changes & upgrades.
    - e. Assure continuity of knowledge and operation.
  5. Coordinate manpower for operation, maintenance, and repairs.
    - a. Train/qualify operators
    - b. Coordinate corrective maintenance thru qualified personnel.
    - \* c. Restrict maintenance activities from those unqualified. Insure Safety.
  6. Assure trip systems are functional, conducting trip tests as required; such as OST's, EPS trips, ect. Be intimately familiar with all trip systems.
- \* There are special hazards and a number of specialized systems and components that could be unsafe or damaged, or cause/allow other damage to occur, if not properly respected. Steam and 480V elect. systems are particularly hazardous. Metering, relaying, and exciter systems are specialty areas which should not be adjusted, repaired, or even troubleshot by inexperienced personnel. For safety to personnel and equipment; If you don't know what you're doing, Don't do anything!





## Advanced Control Recommendations (cont'd)

### 1. Automation Equipment (cont'd)

It should be pointed out that present equipment that performs these functions would be separate and distinct from the plant process computer functions. Only the simplified command interfaces would be tied into the plant computer. T-G manufacturers have held to this philosophy for reliability and proprietary reasons, even to the advent of digital electro-hydraulic control (DEHC) systems.

It would be innovative to tie these controls into the plant process computer. However a thorough review and understanding of the operation and control of such a system would first have to be undertaken. Possibly the best place to start would be thru use of the existing modular local controls on the market and available today. Safety is of paramount concern in T-G controls.

2. Add a T-G low load trip control
3. Find and install an oil flow detector instrument for remote monitoring of T-G bearing oil flows.
4. Change existing controls to a standard operating philosophy to permit tripping of the turbine and generator separately:
  - a. Shut down generator at loads equaling parasitics (as reasonable)
  - b. Generator tripping alone (generator breaker opening) would allow turbine overspeed trips (OST) to be conducted without first tripping both the T & G, then restarting the turbine alone for the OST test.
  - c. Turbine operation after the generator was off-line would allow a turbine steam ramp down to reduce internal turbine thermal stresses prior to turbine trips. Steam conditions could be gradually reduced to 400 psi and 550° F. This would be mandatory for larger T-G's.
  - d. Standardize operations for utility support operators.

Turbine Contacts

American General Lavin

Greg Lavin 415/761-0993

Wally Lavin

Will Stackhouse

Jack

Jim Flaherty

They originally had 4 T-G sets, 2 were renovated. They sold 1 renovated to us, 1 unrenovated elsewhere

2 are left in their yard - 1 renovated, 1 as is (both are complete sets)

GE

Oakland Chris Eastman 415/639-5328  
Dan Devon 415/639-5328  
Mel Burron 415/639-5335  
Fred Warren----- ---Performed initial  
MSEE T-G Alignment  
Matt Sullivan  
Marcus Alden 415/639-5337  
Will Stackhouse-- ---Performed initial  
witnessed inspection

Phoenix Bill Mason 602/943-1376

Fitchberg, Mass Will Corliss 617/343-1000  
(moved from Lynn) Barbara Baloin

Argo Marine

San Francisco Jerry Lewis 415/875-1818

Houston Doug Powers 713/675-6611

Solar One

SCE Plant Manager - Chuck Lopez 619/254-3179  
Warehouse - Sue Workman 619/254-3175  
GE Supplier of Solar- Bill Gibson 818/562-5152  
One T-G Parts

GOLTON MARINE

320 Broad  
Wilmington, CA 90744

Long Beach, CA Joe Johnson 714/549-2550

## Turbine Repairs

Required as of 6/20/85 for GE 750KW Marine T-G  
O&M Manual Naviships GEI 30015  
New 1951, \$1 million/Salvage 1974, \$100K

1. Oil Pump Assembly # 9481468 Part 1  
Ref. O&M Man. Fig. 35 Dwg. 127D296 Item 18  
Oil Pump sereal no. 83468
2. Spiral Gear, Driven #5593428-1 Part 1  
Ref O&M Man. Fig. 68K GE LY CD4-475 G-G2
3. Bearings (Non-standard due to grinding)  
To be determined
4. Steam Seal inserts  
To be determined
5. Other  
To be determined

### Corrective Options

0. Cost/Benefit/Schedule ratio must be determined
- \*1. Replace T-G Set
  - a. Buy new T-G set
  - b. Buy other Lavin T-G set
2. Repair T-G set
  - a. Procure Parts
    1. Fabricate - Sandia/Golton Marine
    2. Buy from GE
    3. Buy from Lavin
    4. Rent from Lavin
  - b. Reinstall components
3. Install/Inspect/Oversee Corrections
  - a. Manufacturers Rep. Required-Mandatory for realignment
  - b. Contracted assistance must be negotiated

\*It has been suggested the existing T-G set be removed and possibly be replaced with another. I discourage this suggestion for two reasons: 1) The cost and time required for removal and reinstallation; 2) The uncertainty of a replacement correcting our problems. We don't presently know the source of our problems, and are not assured that these problems would not continue to occur. Plus we could inherit a whole new set of problems associated with another unit.

and warehousing  
... ..  
... ..  
... ..

San Francisco, California  
Portland, Oregon  
Seattle, Washington  
New York, New York

Greece  
Germany  
United Kingdom  
Antwerp, Belgium  
Norway

Argo International Corporation  
1047 Lathrop Street  
Houston, Texas 77020  
Telephone 713-675-6611

May 8, 1985

Sandia Laboratories  
Box 5300  
Albuquerque N.M. 87185

Attn: Bill Couch

Ref: NYR4585B  
HR57A

# Argo International

Dear Bill,

We are pleased to quote the following for G.E. Turbine S/N 83468 and reduction gear asm. 83550:

- Item 1, Qty. 1 - Gear mounted oil pump assembly:.....\$33,556.00
- Item 2, Qty. 1 - Bronze driven gear .....\$2,935.00

Delivery: Approximately 40 weeks.

Terms: Net 30 days

F.O.B.: Lynn, Mass.

Thank you for this opportunity to be of service.

Very truly yours,

*Doug Powers*  
Doug Powers

Larry W. Nelson's opinion regarding T-G reactivation and further operation:

Don't restore it. As much as I have enjoyed it and would like to see it used, it's only advantages are:

- 1) Political to prove it can function to complete the power plant concept
- 2) To provide full system operating experience
- 3) To slightly recover CRTF electrical power load.

These have already been determined from the MSEE tests.

Off-setting these are its poor system efficiencies, present costs of restoring it, continuous costs required to operate it - particularly man power over and above those otherwise required, and disadvantages to operation. EPGS operation imposes an order of magnitude increase in operating complexity, speaking from experience, as another subsystem to oversee during system operation with all of its associated controls and safety concerns, both locally and at the control room. Maintenance also will be difficult since electrical drawings have not been updated and update sketches are disorganized and slipshod.

As existing technology, thus far it has received little interest and minimal professional support, which accounts for some of the problems we've had with it. I presume due to cost and schedules that this would not significantly change. After all, the RS/Salt system is the new technology under development and the process which receives the most interest. If the T-G is reactivated, I highly recommend procuring professional services in the form of utility operators, utility technical support, and manufacturers consultation services. This subsystem can be very dangerous if not properly operated and maintained.

